

More or Less?

How about both!



Recorder

More: Bigger display

18mm LED allows a high level of visibility

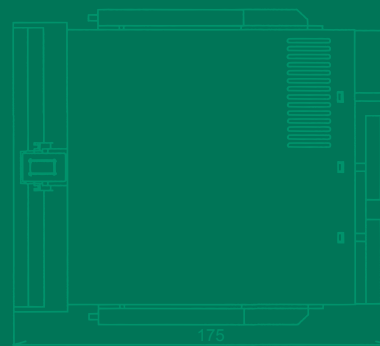
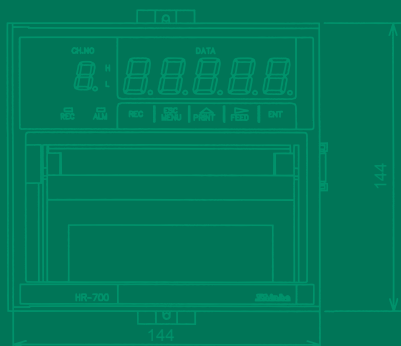

Less: Overall size

Compact, lightweight:
Ideal for small scale control panels



Compact: 150mm in depth, 1.5kg in weight

Available for small panel mounting

Communication interface

Corresponds to FA (factory automation) system via communication interface, RS-232C (standard) or RS-485 (option)

Larger LED display

LED size: 18mm in height

Dust-proof • Drip-proof (IEC529 IP65)

Stands up to even harsh environments such as food related plants and kilns

Safety standard

UL/C-UL and CE marking

Model

HR-70 □, □□□		HR-700 (W144×H144×D150mm)	
Input point	1	1-point (Pen)	Multi-range system (Input types are selectable.)
	2	2-point (Pen)	
	6	6-point (Dot printing)	
Option	C5	Communication function (RS-485)	
	RE1	DI function (Pen)	
	RE6	DI function (Dot printing)	
	FL	Paper-empty detection function	
	LH3	Alarm output function (Pen)	
	LH6	Alarm output function (Dot printing)	

- When ordering, select the alphanumeric characters from the table above for □.
- When adding options, enter the code using a "comma".

Display and operation keys

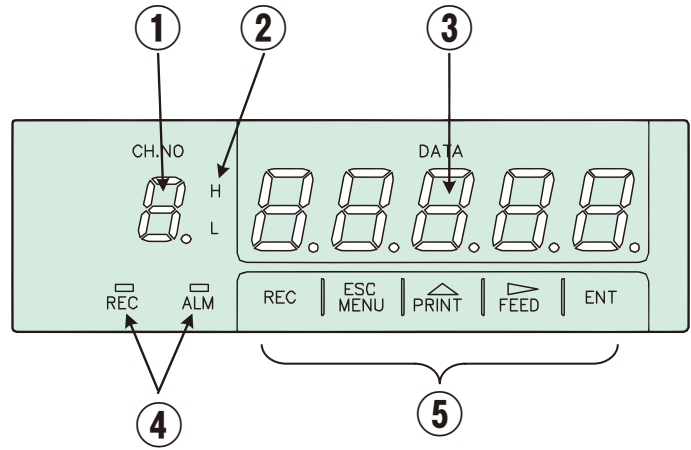

① : Channel number display

Orange LED indicates Channel numbers 1 to 6.

② : Alarm indicator

Red LED indicates the type of the alarm.

[H] is lit when the alarm is High, and [L] is lit when the alarm is Low. Neither of them is lit when there is no alarm.

③ : Data display

Indicates the process variable, date and year, chart feed speed or alarm value (orange).

④ : Status indicators

The [REC] (orange) is lit when recording. The [ALM] (red) is lit when the alarm is being activated.

⑤ : Operation keys

Use these keys for setting and other operations.

Rated scale and accuracy

Input	Range	Measurement (Digital display)		Recording (analog)	
		Measurement accuracy	Resolution	Recording accuracy	
Thermocouple	K1	-200.0 to 1370.0°C	K1: $\pm(0.15\% \text{ of rdg} + 0.7^\circ\text{C})$	Measurement accuracy: $\pm(0.3\% \text{ of recording span})$	
	K2	-200.0 to 600.0°C	K2: $\pm(0.15\% \text{ of rdg} + 0.4^\circ\text{C})$		
	K3	-200.0 to 300.0°C	K3: $\pm(0.15\% \text{ of rdg} + 0.3^\circ\text{C})$		
	However, Range -200 to 100°C, $\pm(0.15\% \text{ of rdg} + 1^\circ\text{C})$				
	E1	-200.0 to 800.0°C	$\pm(0.15\% \text{ of rdg} + 0.5^\circ\text{C})$		
	E2	-200.0 to 300.0°C	$\pm(0.15\% \text{ of rdg} + 0.4^\circ\text{C})$		
	E3	-200.0 to 150.0°C	$\pm(0.15\% \text{ of rdg} + 0.3^\circ\text{C})$		
	J1	-200.0 to 1100.0°C	J1, T1 : $\pm(0.15\% \text{ of rdg} + 0.5^\circ\text{C})$		
	J2	-200.0 to 400.0°C	J2, T2 : $\pm(0.15\% \text{ of rdg} + 0.4^\circ\text{C})$		
	J3	-200.0 to 200.0°C	J3 : $\pm(0.15\% \text{ of rdg} + 0.3^\circ\text{C})$		
	T1	-200.0 to 400.0°C	However, Range -200 to 100°C, $\pm(0.15\% \text{ of rdg} + 0.7^\circ\text{C})$		
	T2	-200.0 to 200.0°C			
	R1	0.0 to 1760.0°C	R1, S, B: $\pm(0.15\% \text{ of rdg} + 1^\circ\text{C})$		
	R2	0.0 to 1200.0°C	R2: $\pm(0.15\% \text{ of rdg} + 0.8^\circ\text{C})$		
S	0.0 to 1760.0°C	However, R1, R2, S: Range 0 to 100°C, $\pm 3.7^\circ\text{C}$			
B	0.0 to 1820.0°C	Range 100 to 300°C, $\pm 1.5^\circ\text{C}$			
RTD	N	0.0 to 1300.0°C	$\pm(0.15\% \text{ of rdg} + 0.7^\circ\text{C})$	Measurement accuracy: $\pm(0.3\% \text{ of recording span})$	
	C	0.0 to 2320.0°C	$\pm(0.15\% \text{ of rdg} + 1^\circ\text{C})$		
	PR40-20	0 to 1880°C	$\pm(0.15\% \text{ of rdg} + 1^\circ\text{C})$		
	However, Range 0 to 300°C, $\pm 4.0^\circ\text{C}$				
	Range 300 to 800°C, $\pm 3.0^\circ\text{C}$				
	Au-Fe	0 to 300 K	$\pm(0.15\% \text{ of rdg} + 1\text{K})$		
	PL-II	-100 to 1390°C	$\pm(0.15\% \text{ of rdg} + 0.7^\circ\text{C})$		
	U	-200.0 to 400.0°C	$\pm(0.15\% \text{ of rdg} + 0.5^\circ\text{C})$		
	L	-200.0 to 900.0°C	However, Range -200 to 100°C: $\pm(0.15\% \text{ of rdg} + 0.7^\circ\text{C})$		
	Pt100 1	-200.0 to 650.0°C	$\pm(0.15\% \text{ of rdg} + 0.3^\circ\text{C})$		
Pt100 2	-200.0 to 200.0°C	$\pm(0.15\% \text{ of rdg} + 0.2^\circ\text{C})$			
DC voltage	JPt100 1	-200.0 to 630.0°C	$\pm(0.15\% \text{ of rdg} + 0.3^\circ\text{C})$	10 μV	
	JPt100 2	-200.0 to 200.0°C	$\pm(0.15\% \text{ of rdg} + 0.2^\circ\text{C})$		
		-10 to 10mV	$\pm(0.2\% \text{ of rdg} + 3 \text{ digits})$		100 μV
		0 to 20mV	$\pm(0.2\% \text{ of rdg} + 3 \text{ digits})$		
		0 to 50mV	$\pm(0.2\% \text{ of rdg} + 2 \text{ digits})$		1mV
		-200 to 200mV	$\pm(0.2\% \text{ of rdg} + 3 \text{ digits})$		
DC current		-1 to 1V	$\pm(0.1\% \text{ of rdg} + 3 \text{ digits})$	10mV	
		-10 to 10V	$\pm(0.3\% \text{ of rdg} + 3 \text{ digits})$		
		0 to 5V	$\pm(0.2\% \text{ of rdg} + 2 \text{ digits})$	1mV	
		4 to 20mA	$\pm(0.2\% \text{ of rdg} + 2 \text{ digits})$		

- In the case of DC current input, connect a shunt resistor (sold separately).

Standard specifications

Measuring point	When ordering, one type can be selected from the following. 1-point (Pen): HR-701, 2-point (Pen): HR-702, 6-point (Dot printing): HR-706
Input	Multi-range (Types are selectable.) • Thermocouple ----- K, J, R, S, B, E, T, C (W/Re5-26), N, PL-II, PR40-20, Au-Fe, U, L • RTD ----- Pt100, JPt100 • DC voltage ----- $\pm 10\text{mV DC}$, 0 to 20mV DC, 0 to 50mV DC, $\pm 200\text{mV DC}$, $\pm 1\text{V DC}$, $\pm 10\text{V DC}$, 0 to 5V DC • DC current ----- 4 to 20mA DC (Connect external 250 Ω shunt resistor which is sold separately.) Scale ----- Refer to the rated scale. Input resistance ----- Thermocouple, DC voltage (mV) range without burnout alarm : 10M Ω or more Thermocouple, DC voltage (mV) range with burnout alarm : 200k Ω or more DC voltage (V) : 1M Ω or more DC current (mA) : 250 Ω (External shunt resistor required) Allowable signal source resistance ---- Thermocouple, DC voltage (mV) range without burnout alarm : 10k Ω or less. Thermocouple, DC voltage (mV) range with burnout alarm : 100 Ω or less. DC voltage (V) : 1k Ω or less RTD : 10 Ω or less per wire
Display	Indication----- Digital indication, 7-segment orange, LED 6 digits (Channel No. display: 1 digit, Data display: 5 digits) Contents----- Channel No., Process variable, Date and year, Chart feed speed, Alarm value Others----- REC: Lights while recording ALM: Red LED lights when alarm occurs in any channel.
Performance	Digital accuracy----- $\pm 0.2\%$ ± 1 digit or less (Within the measurement range of mV and V input. TC and RTD are excluded.) Recording accuracy ----- Measurement accuracy $\pm (0.3\%$ of recording span) Dead band ----- Within 0.2% Normal mode rejection rate ----- 60dB or more (50/60 $\pm 0.1\text{Hz}$) Common mode rejection rate ----- 140dB or more (50/60 $\pm 0.1\text{Hz}$) Interchannel maximum noise voltage----- 200V AC 50/60Hz Vibration resistance ----- 10 to 60Hz 1m/s ² or less Shock resistance ----- 2m/s ² or less Clock accuracy ----- $\pm 50\text{ppm}$ or less
Recording	Chart paper ----- Width: 100mm, Length: 16m, Weight: 83g per stack Recording method----- Pen : Disposable felt pen (1-pen: Red, 2-pen: Green) Dot printing : Wire dot (6-color ink ribbon) (No.1: Purple, No.2: Red, No.3: Green, No.4: Blue, No.5: Brown, No.6: Black) Printing method ----- Pen : Wire dot (1-color ink ribbon) Dot printing : Wire dot (6-color ink ribbon) Step response time ----- Pen : 1 second or less (IEC1143, 95% response) Recording period ----- Pen : Continuous recording for each channel Dot printing : 10 seconds (Selectable from 10sec, 20sec, 30sec, 60sec) Chart speed----- Pen : Selectable from 46 types of speed by front key within the range of 5 to 12000mm/h Dot printing : Selectable from 34 types of speed by front key within the range of 0 to 1500mm/h Chart feed accuracy ----- Within $\pm 0.1\%$ (Does not include expansion or shrink of paper, when it is fed 1000mm or more.)
Alarm	Alarm output is not available. (ALM is lit.) Specify the alarm option(LH3, LH6) when alarm output is required. Setting points----- Maximum 4 points (2 points for High limit and low limit each) can be set per channel. Hysteresis width ----- 0.5% Setting accuracy----- The same as Digital display accuracy
Communications	RS-232C: 1200/2400/4800/9600bps
Supply voltage	100 to 240V AC, 50/60Hz, Allowable voltage fluctuation----- 85 to 264V AC
Power consumption	1-pen: Approx.25VA, 2-pen: Approx.28VA, 6-dot: Approx. 25VA
Insulation resistance	Between each terminal and ground: 20M Ω or more, at 500V DC
Dielectric strength	1.5kV AC for 1min between power terminal and ground terminal 500V AC for 1min between input terminal and ground terminal 200V AC for 1min between input terminal and input terminal
Operating environment	Temperature: 0 to 50 $^{\circ}\text{C}$, Humidity: 20 to 80% RH
Safety standard	UL: Power input rating 100-240V AC File No. E195801
Material/Color	Case: Flame-resistant resin (Black) Door: Flame-resistant resin (Transparent)
Door	Dust-proof and Drip-proof (IEC529 IP65)
Mounting	Panel mounting (Vertical panel), Allowable inclination angle: Backward 0 to 30 $^{\circ}$ or less
Weight	HR-701: Approx. 2kg, HR-702: Approx. 2.5kg, HR-706: Approx. 1.5kg
Attached functions	Skipping, Servo-stop, Self-diagnosis, Zone recording, Partial compression/expansion recording, Decade recording and indication, Tag number setting, Copy function, Input offset setting, Computation, Interchannel computation, Scaling, Burnout, Memory back up (Clock function is protected by the internal lithium battery. [Battery life: Approx. 10 years] Setting/Corrected data is protected by non-volatile memory.), Asynchronous print mode, Printer gap correction function
Accessories	Chart paper: 1 volume, Ribbon cassette (Dot printing: 1, Pen: 1), Cartridge pen (1-pen: 1, 2-pen: 2), Packing: 1, Mounting brackets: 1 set, Instruction manual: 1 copy

Optional specifications

Communication function [C5]	Communication line: RS-485, Communication speed: 1200/2400/4800/9600bps
DI function [RE1] [RE6]	Settable at 3 points (Maximum) Chart feed Start/Stop : Relay contact ON: Start Relay contact OFF: Stop Changing chart speed : Changes 1st with tuning to ON and 2nd with OFF Comment printing : Prints comments with contact ON (Up to 16 characters per line) Log printing : Prints with contact ON Date and time printing : Prints date and time with contact ON
Paper-empty detection function [FL]	Detects the paper tray is empty, stops recording, and activates the alarm. (When adding this option, [LH3] or [LH6] option needs to be added.)
Alarm output function [LH3] [LH6]	Output number • Pen : 3 points (Built-in option, a contact) • Dot printing : 6 points (Built-in option, a contact) Contact capacity : 250V AC Maximum 3A (Resistive load) 30V DC Maximum 3A (Resistive load) 125V DC Maximum 0.5A (Resistive load)

Terminal arrangement

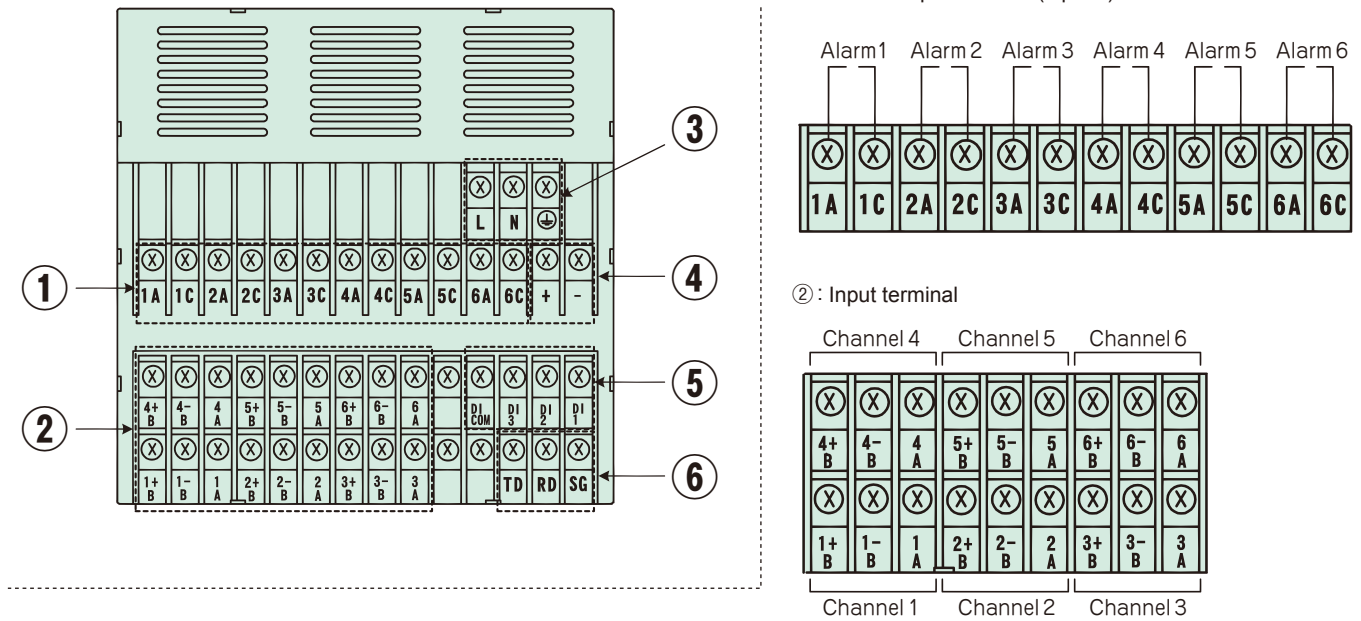

③ : Power supply terminal

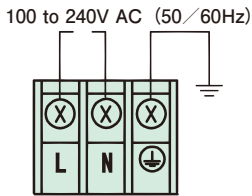

④ : RS-485 Communication terminal (Option)

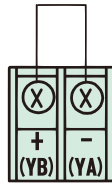

⑤ : DI Function terminal (Option)

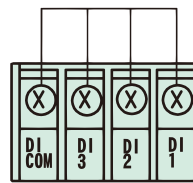

⑥ : RS-232C Communication terminal

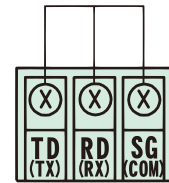

External dimensions (Scale: mm)

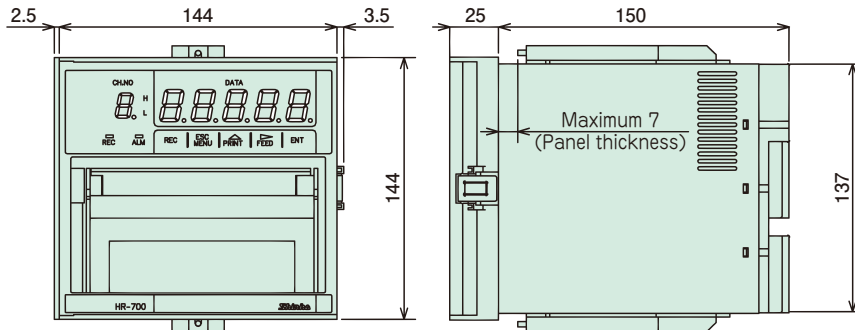

Panel cutout (Scale: mm)

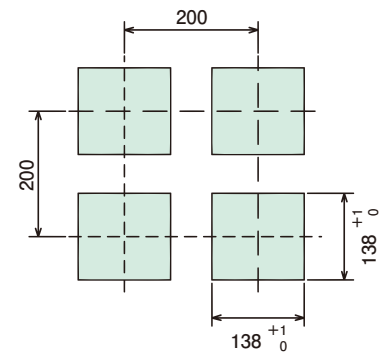

Allowable inclination angle: Backward 0 to 30° or less

SAFETY PRECAUTIONS

- To ensure safe and correct use, thoroughly read and understand the manual before using this instrument.
- This instrument is intended to be used for industrial machinery, machine tools and measuring equipment. Verify correct usage after consulting purpose of use with our agency or main office. (Never use this instrument for medical purposes with which human lives are involved.)
- External protection devices such as protection equipment against excessive temperature rise, etc. must be installed, as malfunction of this product could result in serious damage to the system or injury to personnel. Also proper periodic maintenance is required.
- This instrument must be used under the conditions and environment described in the manual. Shinko Technos Co., Ltd. does not accept liability for any injury, loss of life or damage occurring due to the instrument being used under conditions not otherwise stated in this manual.

Caution with respect to Export Trade Control Ordinance

To avoid this instrument from being used as a component in, or as being utilized in the manufacture of weapons of mass destruction (i.e. military applications, military equipment, etc.), please investigate the end users and the final use of this instrument. In the case of resale, ensure that this instrument is not illegally exported.

· This catalog is as of February 2009, and specifications are subject to change without notice.
 · If you have any inquiries, please consult us or our agency.

SHINKO TECHNOS CO., LTD. OVERSEAS DIVISION

Reg. Office : 2-5-1, Senbahigashi, Minoo, Osaka, 562-0035, Japan
 Tel : 81-72-727-6100
 Fax : 81-72-727-7006
 URL : <http://www.shinko-technos.co.jp>
 E-mail : overseas@shinko-technos.co.jp