



GasMultiBloc® Control and safety combination One-stage mode

MBC-65...
MBC-120...

DUNGS®
Combustion Controls

7.10

- Compact design
(105 mm long)
- The following components can be integrated:
 - Microfilter
 - 2 x A valves
 - Servopressure regulator
 - Pressure switch
- Max. operating pressure
 - MBC-65: $p_{max.}$ 200 mbar (20 kPa)
 - MBC-65-N...: $p_{max.}$ 65 mbar (6.5 kPa)
 - MBC-120: $p_{max.}$ 360 mbar (36 kPa)
 - MBC-120-N...: $p_{max.}$ 100 mbar (10 kPa)
- Degree of protection: IP 54
- Radio interference suppression; interference level N
- Ambient temperature:
-15 °C bis +60 °C
- Other available servo pressure regulator models:
 - Zero pressure
 - Constant pressure regulator
Ratio
 $V=p_{Br}/p_L=0,45:1...1:1$

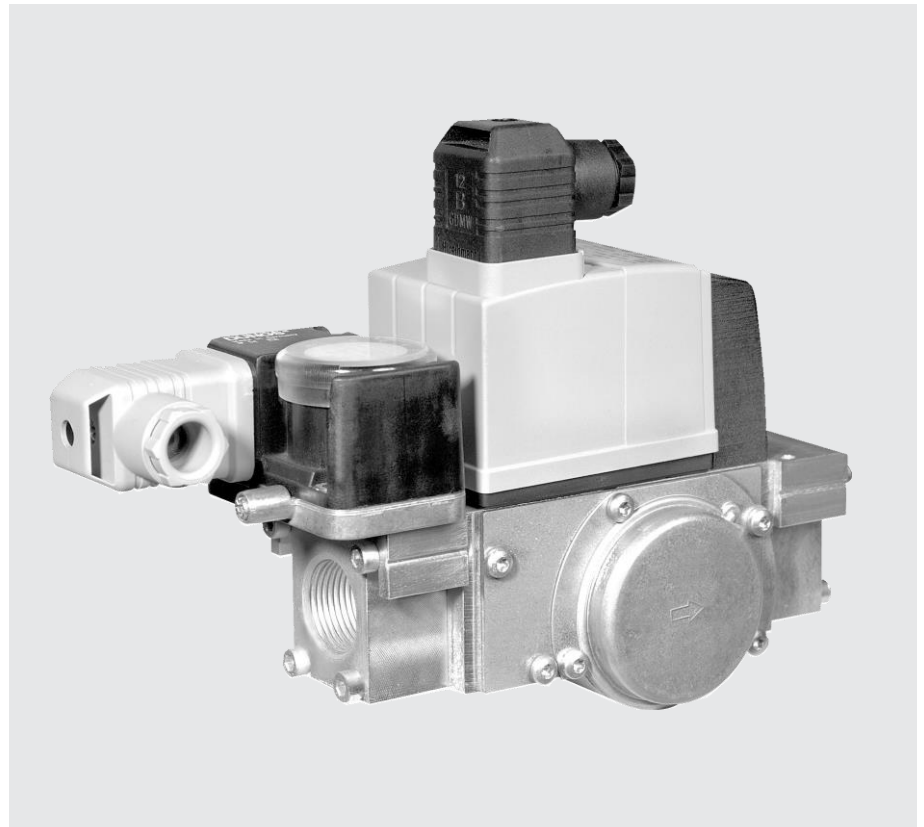

Technical description

Filter, valves, regulator and pressure switch are integrated in the DUNGS GasMultiBloc® to form a compact fitting.

- Dirt trap: Microfilter
- One regulator and two valves
- Two valves (fast opening)
- Regulator (fast opening) or regulator (slow opening)
- Solenoid valves as per DIN EN 161 Class A Group 2
 - MBC-65 to 200 mbar (20 kPa)
 - MBC-120 to 360 mbar (36 kPa)
- Sensitive setting of output pressure via servopressure regulator as per DIN EN 88 Class C Group 2
- Opening delay by means of damped pressure rise
- High flow values at low pressure difference
- DC voltage solenoid drive
- Main valve restrictor downstream of regulator

- Flange connections with tube threads as per ISO 7/1
- Easy-to-mount, small dimensions, low weight

Application

The modular system provides individual solutions in gas safety and control systems. Suitable for gases of gas families 1, 2, 3 and other neutral gaseous media.

Approvals

EC type testing certificate as per:

- EC-Gas Appliances Regulation
- EC-Pressure Equipment Directive

 Approvals in other important gas consuming countries.



Functional description

Gas flow

1. Valves V1 and V2 are closed. Inlet pressure is applied to chamber A until valve V1 is seated.
2. The min. pressure switch is connected to Chamber A by a bore-hole. If the inlet pressure exceeds the reference value set on the pressure switch, it switches to the automatic gas burner control.
3. After a release signal from the automatic gas burner control, valves V1 and V2 open. The gas flow through chambers A, B, C and D of the GasMultiBloc is released.

Dirt trap device

Dirt trap device, fine-meshed filter (1) to protect the fitting.

Operating mode of valve V1 and valve V2

The plungers of valves V1 and V2 are connected to the valve plate units. On opening, the plungers pretension the closing springs. The valves open completely without limitation.

Closing function

When the power supply of solenoid coils of V1 and V2 is interrupted, the valves are closed within < 1s by means of pressure springs.

Operating mode of servopressure regulator

The servopressure regulator equalises the pressure fluctuations in the power supply. The output pressure is set at the reference value adjustment device (14). The servopressure regulator controls the pressure regulator (5) via nozzle (7). The "slow opening" function is enabled by a damped pressure increase. The opening time of MBC-120 cannot be set.

With MBC-120, the opening behaviour can be adjusted at high operating pressure values.

Start flow adjustment

The adjustment screw (15) for the start flow restrictor (10) is closed (factory setting).

The start flow can be set by opening the restrictor up to approx. 80 % of the main flow.

Main flow adjustment

The adjustment screw (13) for the main flow restrictor (9) is completely open (factory setting). The servopressure regulator

Sectional view MBC-65-DLE-S20

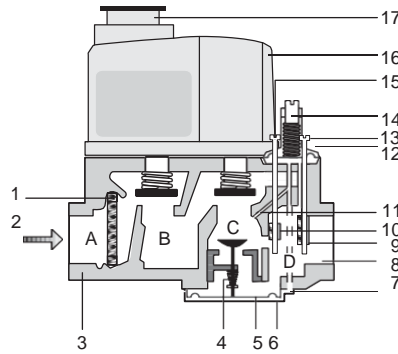

1. Microfilter
2. Inlet P1
3. Housing
4. Spring, gas pressure regulator
5. Diaphragms, gas pressure regulator
6. Cover side
7. Nozzle
8. Outlet P3
9. Main flow restrictor
10. Start gas restrictor
11. Damper
12. Servopressure regulator
13. Adjustment screw - main flow
14. Reference value adjustment device - pressure regulator
15. Adjustment screw - start flow
16. Solenoid housing V1, V2
17. Electrical connection
- 18 Setting of opening time (only MBC-120)

Pressure taps

MBC-65

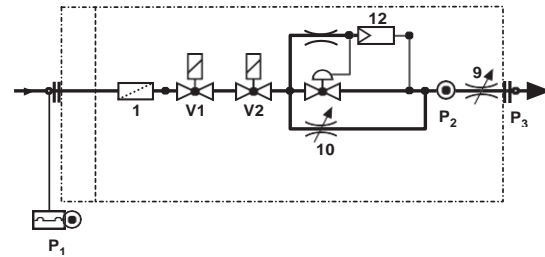

MBC-120

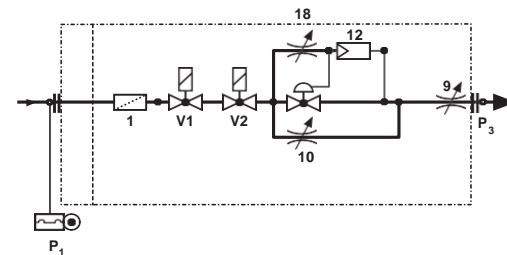

keeps the output pressure upstream of the main flow restrictor constant. The burner pressure is determined when the output pressure and the main flow restrictor (9) are adjusted.

Gas pressure switch

The gas pressure switch monitors the gas pressure on the inlet side; the pressure switch is preset.

Start-up response

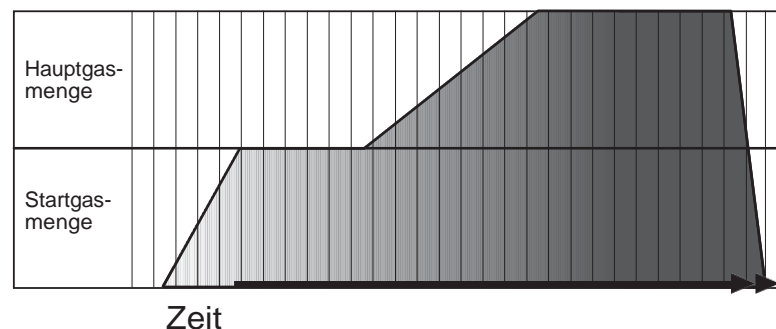



Specifications

Nominal widths	MBC-65...	MBC-120...
Flange with tube threads as per ISO 7/1 (DIN2999)	Rp 3/8, Rp 1/2	Rp 3/4
Max. operating pressure	MBC-65-... MBC-65-N../S00/S02 MBC-120-... MBC-120-N../S00/S02	p_{max.} 200 mbar (20 kPa) p_{max.} 65 mbar (6.5 kPa) p_{max.} 360 mbar (36 kPa) p_{max.} 100 mbar (10 kPa)
Output pressure ranges P3 (p_a)	MBC-...-DLE S20/S22 MBC-...-DLE S40/S42 MBC-...-ND/S00/S02	3 mbar to 15 mbar (0.3 to 1.5 kPa) 4 mbar to 37 mbar (0.4 to 3.7 kPa) 0 ± 0.2 mbar (0 ± 0.02 kPa)
Media	Gases of gas families 1, 2, 3 and other neutral gaseous media	
Ambient temperature	-15 °C to +60 °C	
Dirt trap device	Filter with 120µm mesh width	
Pressure switches	Types GW A5, GW A2, NB A2, ÜB A2 can be mounted as per DIN EN 1854. For further information, refer to datasheet GW...A2 No. 213 372 and datasheet GW...A5 No. 225 756	
Pressure regulator	Servopressure regulator as per DIN EN 88 Class C. Reference value spring is installed permanently (no spring replacement possible). Blow-out line over roof top must not be installed. Internal pulse tap available.	
Solenoid valve V1	Valve as per DIN 161 Class A Group 2, fast closing, fast opening	
Solenoid valve V2	Valve as per DIN 161 Class A Group 2, fast closing, fast opening	
	Design	Valves V1 and V2 Pressure regulator
	MBC-... -DLE	fast closing slow opening
	MBC-... -ND	fast closing slow opening, proportional regulator zero pressure regulator
Measuring/ignition gas connection	See "Pressure taps", page 2	
Voltage/frequency	~(AC) 50-60 Hz 220-230 V - 15 % + 10 % Preferred voltages: 110-120 VAC, 24 VDC	
Electrical connection	Plug connection as per DIN EN 175301-803 for valves and pressure switches or DIN 46342 for safety extra-low voltage	
Performance/power consumption	MBC-65... 24 VA per ~(AC) 230 V, 20 °C	
Switch-on period	MBC-120... 24 VA per ~(AC) 230 V, 20 °C	
Degree of protection	100 % ED	
Radio interference suppression	IP 54 as per IEC 529 (EN 60529) Interference level N	
Material of gas-wetted parts	Housing Diaphragms, seals Solenoid drive	Aluminium NBR basis, cork Steel, brass, aluminium
Installation position	Vertical, with solenoid pointing upwards or lying with horizontal solenoid and their intermediate layers	



Adjustment range

Application of constant pressure regulator

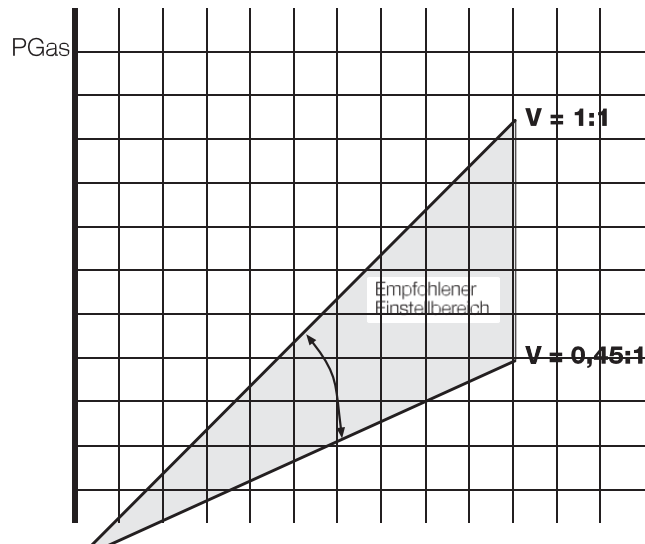
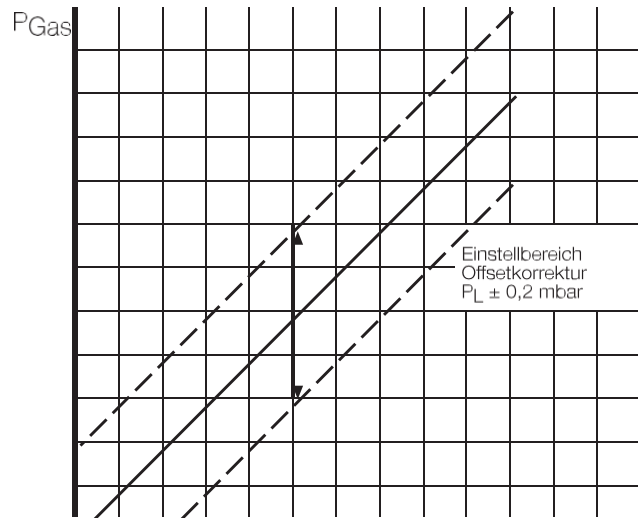

Adjustment range

Application of zero pressure regulator

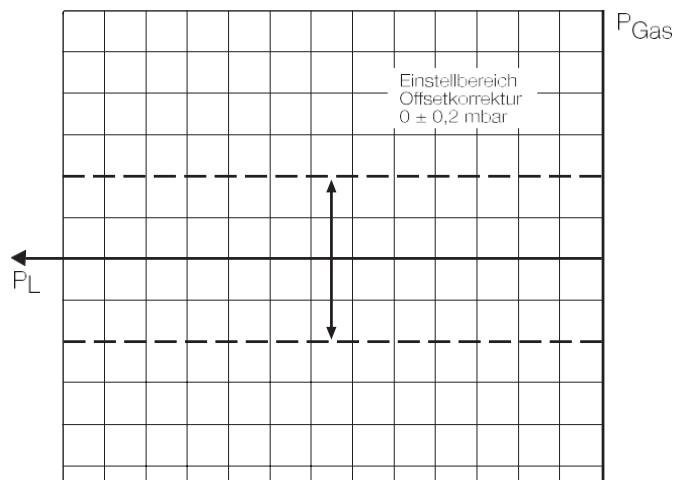

Adjustment instructions

Rapid and simple adjustment by means of:

- Adjust offset correction using setting screw on servo regulator.
- Adjust maximum flow using flow restriction screw.



Volume flow pressure difference characteristics in steady state with microsieve

MBC-65...

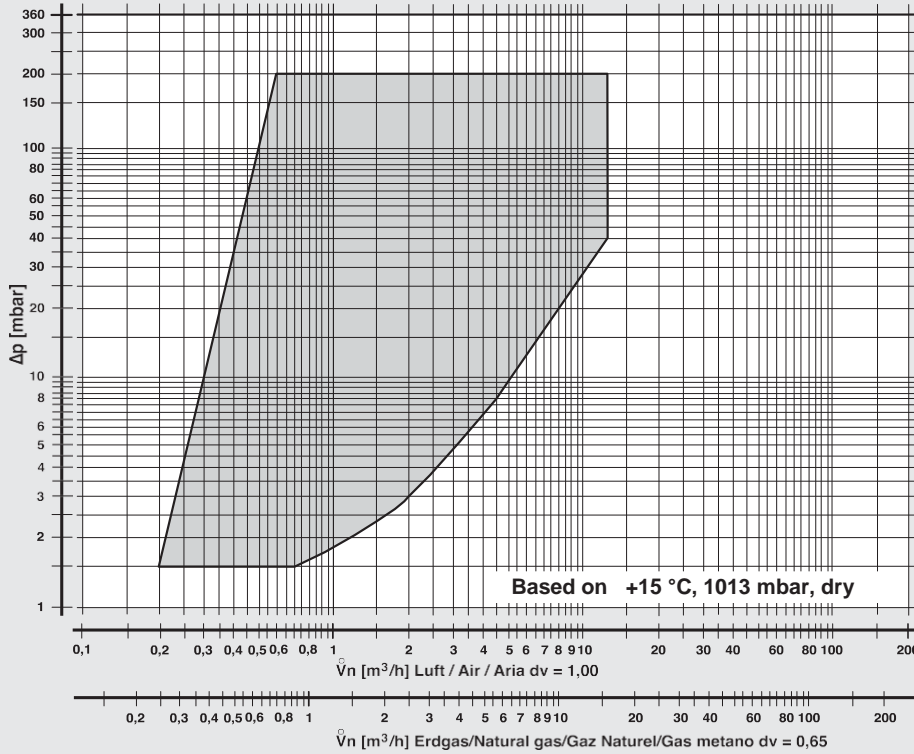

MBC-120...

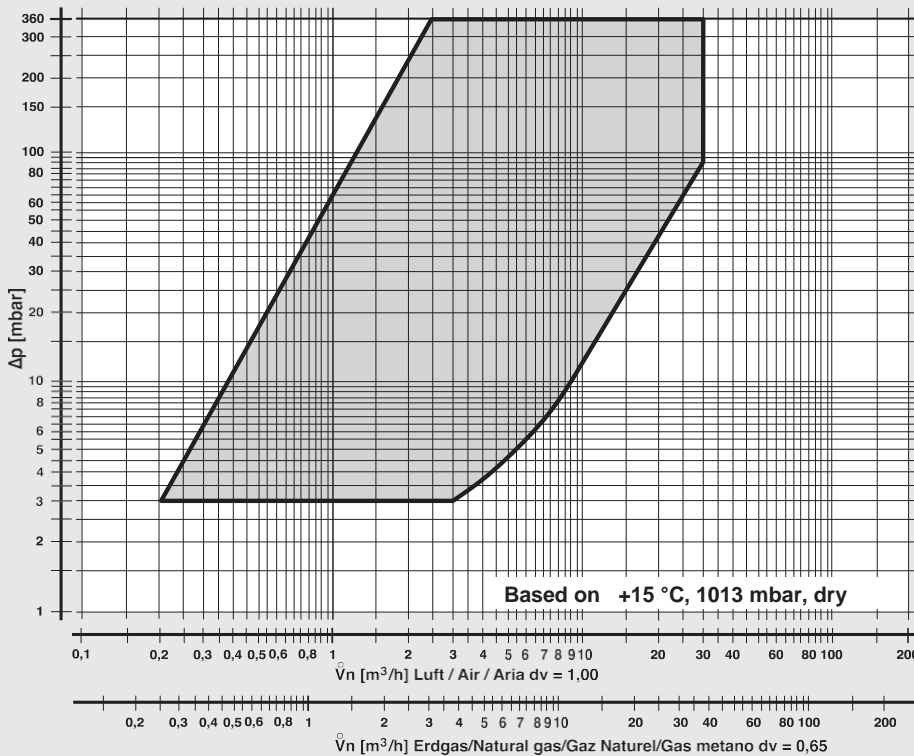

f =

$$f = \sqrt{\frac{\text{Air density}}{\text{Density of gas used}}}$$

Gas type	Density [kg/m³]	dv	f
Natural gas	0.81	0.65	1.24
City gas	0.58	0.47	1.46
Liquefied gas	2.08	1.67	0.77
Air	1.24	1.00	1.00

$$\dot{V}_{\text{verwendetes Gas/gas used/ gaz utilisé/gas utilizzato}} = \dot{V}_{\text{Luft/air/aria}} \times f$$



บริษัท เอดีดี เฟอร์เนส จำกัด

ADD FURNACE CO.,LTD.

44 ซอยบรมราชชนนี 70 ถนนบรมราชชนนี แขวงศาลาธรรมสพน์ เขตทวีวัฒนา กรุงเทพฯ 10170

โทร: 02-888-3472 โทร: ออกแบบ:08-08-170-170 แฟกซ์: 02-888-3258

https://www.add-furnace.com E-mail: sales@add-furnace.com

GasMultiBloc®
Control and safety combination
One-stage mode

MBC-65-...
MBC-120-...

DUNGS®
Combustion Controls

Dimensions [mm]

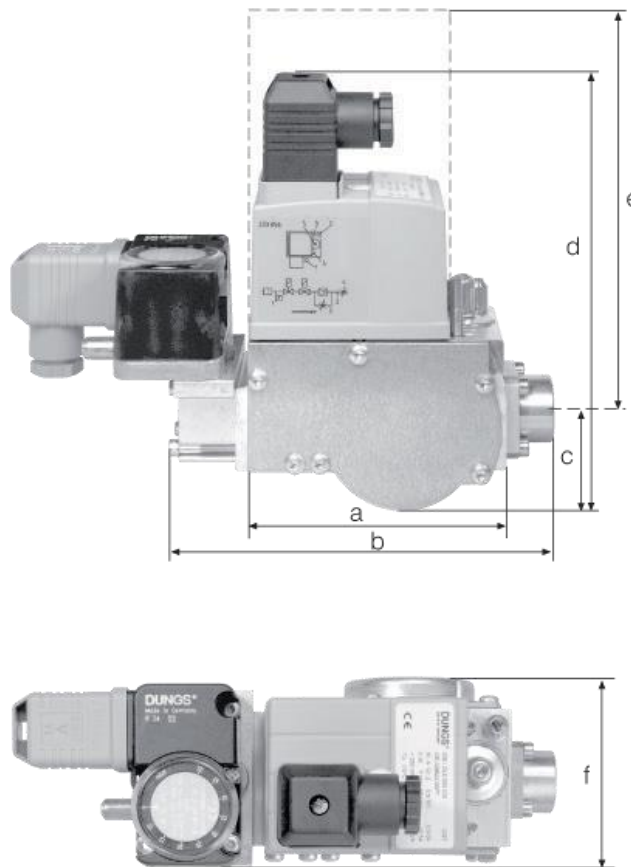

Type	Rp	Opening time	Dimensions [mm]						Rating/Power Consumption ~(AC) 230 V; + 20 °C	Weight [kg]
			a	b	c	d	e	f		
MBC-65	Rp 1/2	< 1 s	105	148	31	160	226	76	25 VA	1,5
MBC-120	Rp 3/4	< 20 s	105	155	37	165	232	82	25 VA	1,6

We reserve the right to make any changes in the interest of technical progress.