

## Gas and air filter

GF/1: Rp 1/2 - Rp 2 GF/3: DN 40

GF/4: DN 50 - DN 100

GF:DN 125 - DN 200



### Technical description

Filter for interior gas lines as per DIN 3386 with high dust storage capacity.

GF/1: Threaded connection as per ISO 7/1.

GF/3, GF/4 and GF: Flange connection as per DIN EN 1092-1.

**Max. flow velocity: 20 m/s.**

**Installation option for pressure measurement point for filter monitoring.**

### Application

Type GF/1, GF/3, GF/4 and GF gas **and air filter for protecting downstream fittings. Filter suitable for gases of families 1,2,3 and other neutral gaseous media.**

### Approvals

**EC type testing certificate as per:**

- EC-Gas Appliances Regulation
- **EC-Pressure Equipment Directive**

**Approvals in other important gas consuming countries.**

**Specifications - Threaded version**

Nominal diameter	DN15 Rp 1/2 as per ISO 7/1	DN20 Rp 3/4	DN25 Rp 1	DN40 Rp 1 1/2	DN50 Rp 2
Max. operating pressure	GF 5.../1 GF40.../1	0.5bar(50kPa) 4.0 bar (400 kPa)			
Max. flow velocity	≤20m/s				
Ambient temperature	-15 °C to +80 °C				
Pore width of filter element	≤ 50 μm				
Measuring/ignition gas connection	GF5.../1: G1/4 screw connection as per DIN ISO 228 upstream and downstream of filter element, on housing cover GF40.../1: G 1/4 screw plugs as per DIN ISO 228 upstream and downstream of filter element, on housing cover				
Materials	Housing Seals Random laid nonwoven fabric Filter holder	aluminium cast NBR PP,PE POM			
Installation position	Any, preferred position: with cap vertical				

**Functional description**

Filter designed for installation in interior gas lines and compressed air lines to protect downstream fittings. Filter element made of random laid nonwoven polypropylene fabric and metal support frame with pore width of 50 μm.

Dust, chips and rust as well as other physical gas-accompanying materials and fouling are retained using the random laid nonwoven fabric.

If the dust storage capacity is exceeded or if there is an excessive pressure difference, the filter loses its protective function.

**Installation**

Refer to gas flow direction indicated by arrow on filter housing.

Provide sufficient space for changing the filter element.

If the filter cap is mounted in vertical position, it is easier to clean the filter housing.

After installation, perform leak test.

**⚠ Avoid direct contact between hardening masonry, concrete walls, floors and filter.**

**Change filter element**

- At least once a year
- If pressure difference has increased by 100% compared to new filter
- When pressure difference exceeds 50 mbar

**Filter monitoring**

GF5.../1: The G 1/4 screw plugs can be replaced by suitable screw connections. Connect an gas differential pressure switch to monitor the pressure difference.

**Gas filter with differential pressure switch**

**A** G 1/4 screw connection **only** GF5.../1

**B** Differential pressure switch for gas

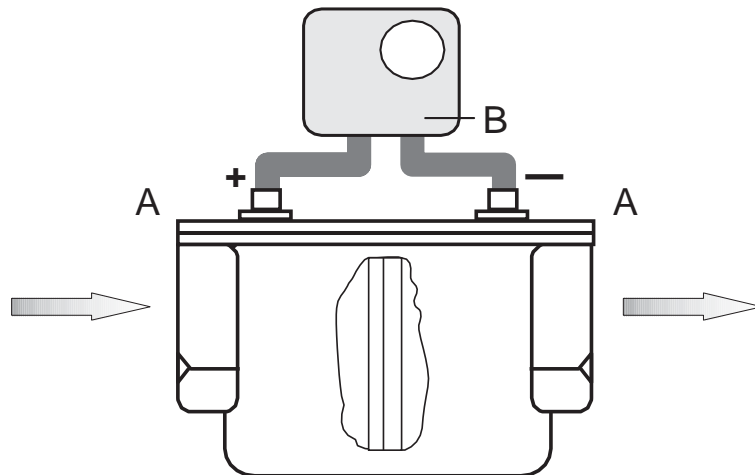

Dimensions (mm) - Threaded version

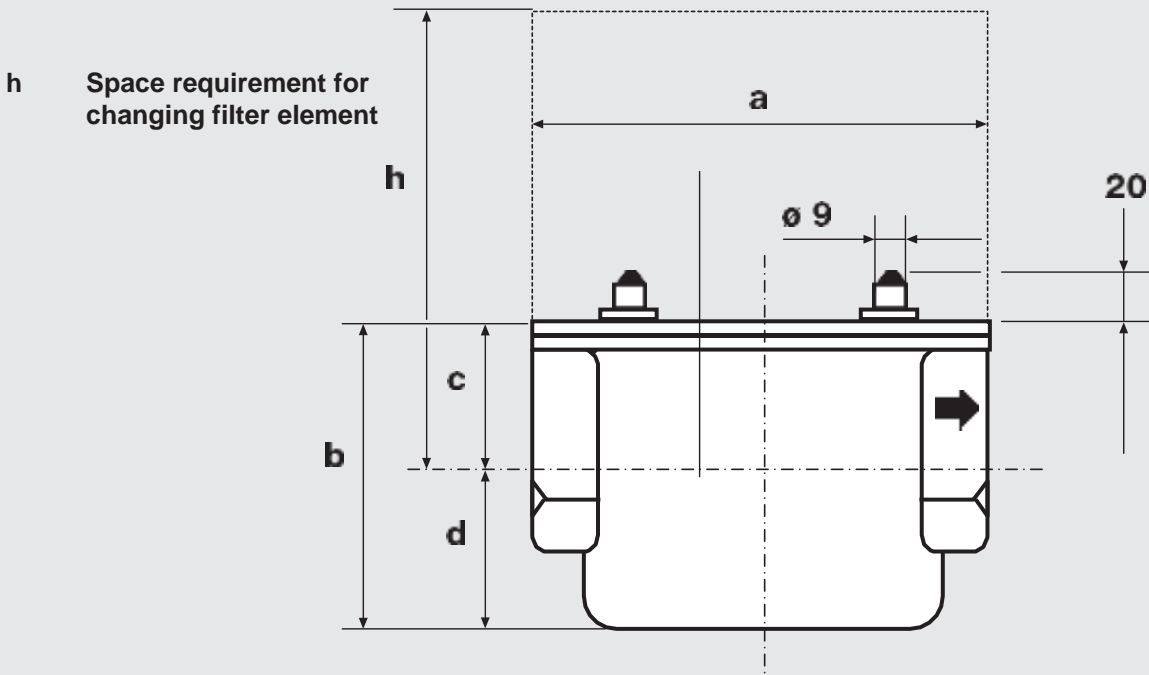

Type	Order No.	Max. operating pressure [bar]	connection Rp	Design	Dimensions [mm]					Weight [kg]
					a	b	c	d	h	
<b>GF 505/1</b>	066 191	<b>0.5</b>	Rp 1/2	MS	<b>120</b>	<b>90</b>	<b>35</b>	<b>55</b>	<b>125</b>	<b>0.7</b>
<b>GF 507/1</b>	066 209	<b>0.5</b>	Rp 3/4	MS	<b>120</b>	<b>90</b>	<b>35</b>	<b>55</b>	<b>125</b>	<b>0.7</b>
<b>GF 510/1</b>	066 217	<b>0.5</b>	Rp 1	MS	<b>160</b>	<b>105</b>	<b>54</b>	<b>51</b>	<b>159</b>	<b>1.1</b>
<b>GF 515/1</b>	<b>066 225</b>	<b>0.5</b>	RP 1 1/2	MS	<b>160</b>	<b>105</b>	<b>54</b>	<b>51</b>	<b>159</b>	<b>1.1</b>
<b>GF 520/1</b>	066 233	<b>0.5</b>	Rp 2	MS	<b>186</b>	<b>140</b>	<b>75</b>	<b>65</b>	<b>215</b>	<b>1.9</b>
<b>GF 4005/1</b>	228 073	<b>4.0</b>	Rp 1/2	VS	<b>120</b>	<b>90</b>	<b>35</b>	<b>55</b>	<b>125</b>	<b>0.7</b>
GF 4007/1	228 074	<b>4.0</b>	Rp 3/4	VS	<b>120</b>	<b>90</b>	<b>35</b>	<b>55</b>	<b>125</b>	<b>0.7</b>
GF 4010/1	<b>228 075</b>	<b>4.0</b>	Rp 1	VS	<b>160</b>	<b>105</b>	<b>54</b>	<b>51</b>	<b>159</b>	<b>1.1</b>
<b>GF 4015/1</b>	228 076	<b>4.0</b>	Rp 1 1/2	VS	<b>160</b>	<b>105</b>	<b>54</b>	<b>51</b>	<b>159</b>	<b>1.1</b>
GF 4020/1	228 077	<b>4.0</b>	Rp 2	VS	<b>186</b>	<b>140</b>	<b>75</b>	<b>65</b>	<b>215</b>	<b>1.9</b>

MS = screw connection

VS = screw plug

**Specifications - Flanged version**

<b>Nominal flange size</b>	<b>DN 40 DN 50 DN 65 DN 80 DN 100 DN 125 DN 150 DN 200</b> Flange connection as per DIN EN 1092-1								
<b>Max. operating pressure</b>	<b>4.0bar(400kPa)</b>								
<b>Max. flow velocity</b>	<b>≤20m/s</b>								
<b>Ambient temperature</b>	<b>-15 °C to +80 °C</b>								
<b>Pore width of filter element</b>	<b>≤ 50 µm</b>								
<b>Measuring gas connection</b>	<b>G1/4 screw plugs as per DIN ISO 228 upstream and downstream of filter element, on left of housing</b>								
<b>Materials</b>	<table border="0"> <tr> <td><b>Housing</b></td> <td><b>aluminium cast</b></td> </tr> <tr> <td>Seals</td> <td>NBR</td> </tr> <tr> <td><b>Random laid nonwoven fabric</b></td> <td><b>PP</b></td> </tr> <tr> <td><b>Support frame</b></td> <td><b>Stainless steel</b></td> </tr> </table>	<b>Housing</b>	<b>aluminium cast</b>	Seals	NBR	<b>Random laid nonwoven fabric</b>	<b>PP</b>	<b>Support frame</b>	<b>Stainless steel</b>
<b>Housing</b>	<b>aluminium cast</b>								
Seals	NBR								
<b>Random laid nonwoven fabric</b>	<b>PP</b>								
<b>Support frame</b>	<b>Stainless steel</b>								
<b>Installation position</b>	<b>Any, preferred position: with cap vertical</b>								

**Functional description**

Filter designed for installation in interior gas lines and compressed air lines to protect downstream fittings. Filter element made of random laid nonwoven polypropylene fabric and metal support frame with pore width of 50

Dust, chips and rust as well as other physical gas-accompanying materials and fouling are retained by the random laid nonwoven fabric.

If the dust storage capacity is exceeded or if there is an excessive pressure difference, the filter loses its protective function.

**Installation**

Refer to gas flow direction indicated by arrow on filter housing.

Provide sufficient space for changing the filter element.

If the filter cap is mounted in vertical position, it is easy to clean the filter housing.

After installation, perform leak test.

**Important: Avoid direct contact between hardening masonry, concrete walls, floors and filter.**

**Change filter element**

- At least once a year
- If pressure difference has increased by 100% compared to new filter
- When pressure difference exceeds 50 mbar

**Filter monitoring** The G1/4 screw plugs can be replaced with suitable screw connections. This permits the connection of an gas differential pressure switch to monitor pressure difference.

**GF .../3, GF .../4 gas filter section**

- 1 O ring
- 2 **Cover**
- 3 Housing
- 4 **Filter element**

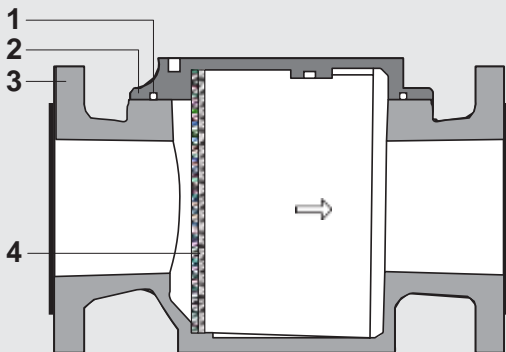

**Filter monitor**

- A **Measurement connection**
- B **Differential pressure switch for gas**

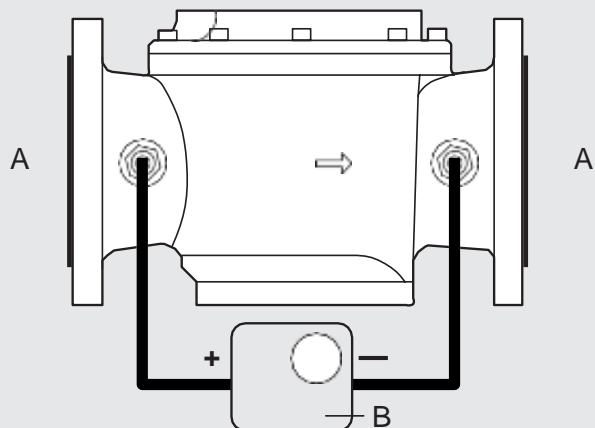



Dimensions (mm) - Flanged version

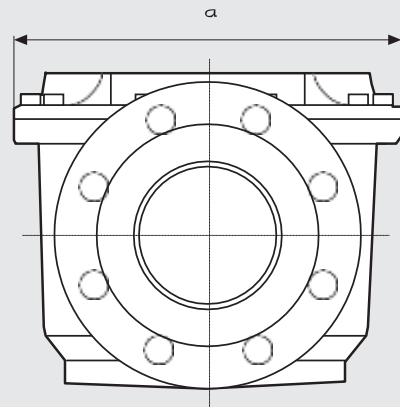
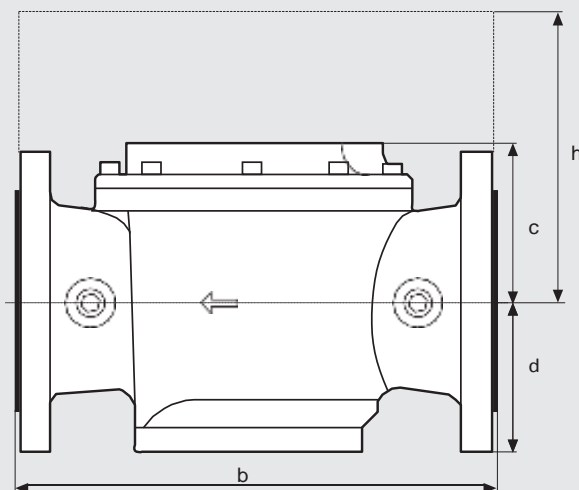

h Space requirement for changing filter element

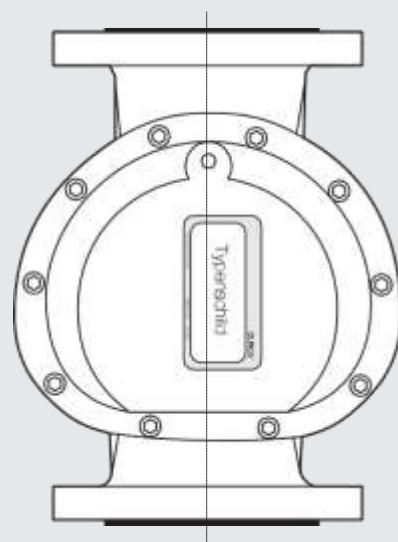

Type	Order No.	Max. operating pressure [bar]	DN connection	Dimensions [mm]					Weight [kg]
				a	b	c	d	h	
GF 40040/3	222 637	4.0	DN 40	132	<b>195</b>	49	47	96	<b>2.8</b>
<b>GF 40050/4</b>	<b>256 408</b>	4.0	<b>DN 50</b>	170	220	76	60	119	<b>4.1</b>
<b>GF 40065/4</b>	<b>256 409</b>	4.0	<b>DN 65</b>	194	<b>252</b>	<b>95</b>	93	188	<b>6.0</b>
GF 40080/4	<b>256 410</b>	4.0	DN 80	236	300	103	107	206	<b>8.3</b>
GF 40100/4	<b>256 411</b>	4.0	DN 100	282	<b>352</b>	119	111	229	<b>12.3</b>
<b>GF 40125</b>	218 162	4.0	<b>DN 125</b>	281	360	182	183	<b>365</b>	<b>19.5</b>
<b>GF 40150</b>	218 163	4.0	<b>DN 150</b>	281	<b>385</b>	<b>257</b>	<b>259</b>	<b>516</b>	<b>25.5</b>
GF 40200	218 164	4.0	DN 200	388	<b>455</b>	236	239	<b>475</b>	<b>40.0</b>

Volumetric flow/pressure drop characteristic

Pressure loss  $\Delta p$  [mbar] for natural gas (dv = 0,64)

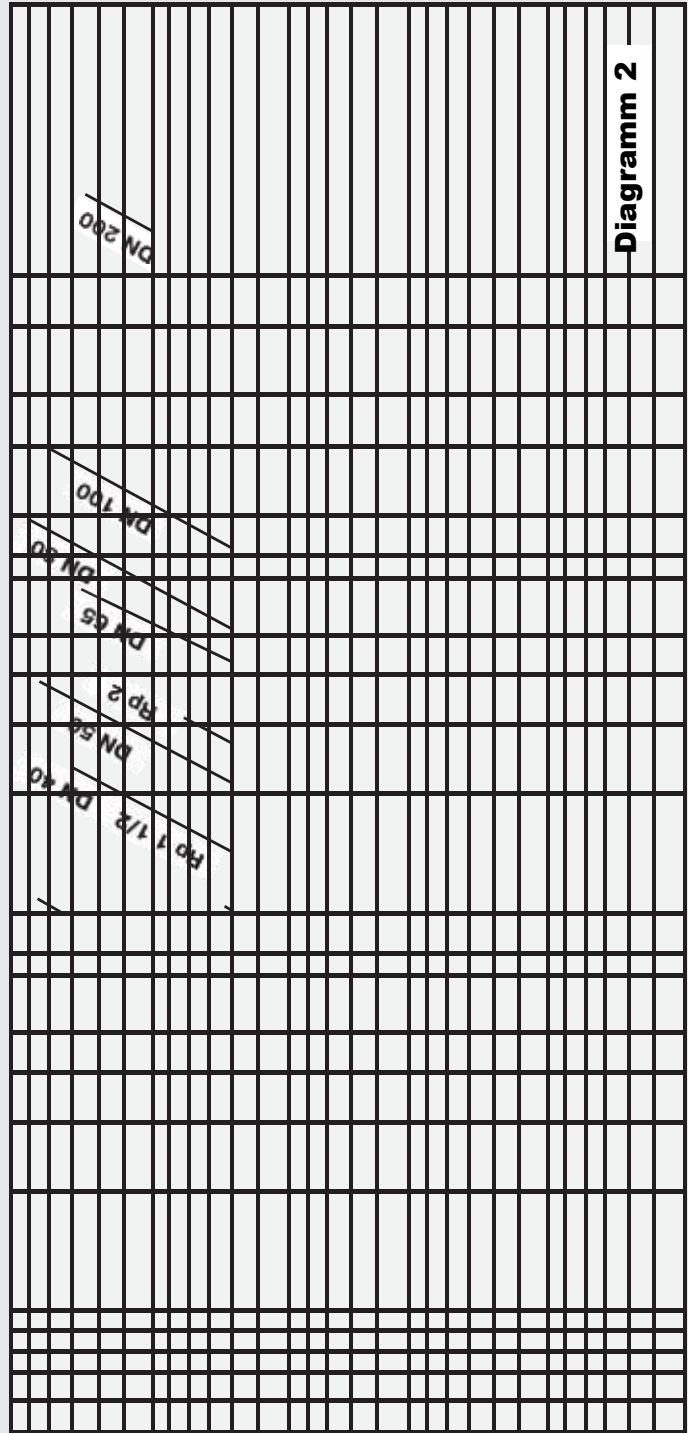

Diagram 2

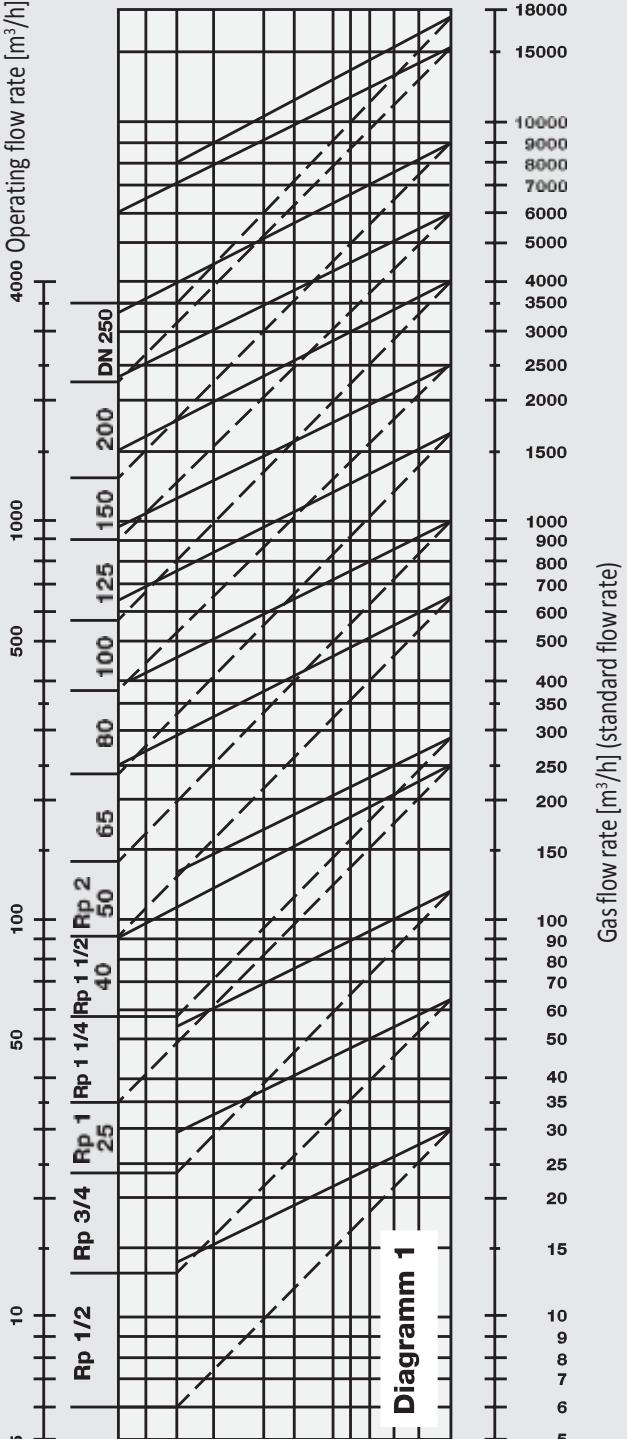
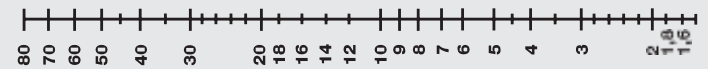

Diagram 1



Pressure loss  $\Delta p$  [mbar] for air (dv = 1)

Inlet pressure  $p_e$  [bar]

**Diagram 1**

- Determining the nominal diameter
- Conversion of the flow rate from standard flow rate to operating flow rate.

**Diagram 2**

- Determining the pressure loss ( $\Delta p$ ).

**Procedure**

**Determining the filter size**

- 1.1 Define the flow rate as a standard flow rate on the lower scale.
- 1.2 Draw a parallel reference line along the diagonal dashed line up to the actual inlet pressure.
- 1.3 You will find region for minimum filter size vertically above this point of intersection. You can read the corresponding flow rate from the scale above.

**Procedure**

**Determining the pressure loss**

- 2.1 Define the flow rate as a standard flow rate on the lower scale.
- 2.2 Draw a parallel reference line along the diagonal solid line up to the actual inlet pressure.
- 2.3 Go from this point of intersection vertically upwards to diagram 2. The pressure loss for gas and air can be read at the point of intersection with the characteristic curve for the previously determined filter size.

All specified values refer to filter mats in new condition.

The pressure loss for other gases can be estimated from the value valid for air by multiplying this value with the density ratio.

**Example**

**Determining the filter size**

- 1.1 Flow rate (standard flow rate) 2,000 m<sup>3</sup>/h
- 1.2 Inlet pressure 4 bar
- 1.3 Determining the filter size: min. DN100, Determining the flow rate: 400

**Determining the pressure loss**

- 2.1 Flow rate (standard flow rate) 2,000 m<sup>3</sup>/h
- 2.2 Inlet pressure 4 bar
- 2.3 Determining the pressure loss for gas:  $\Delta p = 15$  mbar  
 Determining the pressure loss for air:  $\Delta p = 23$  mbar

**Example**

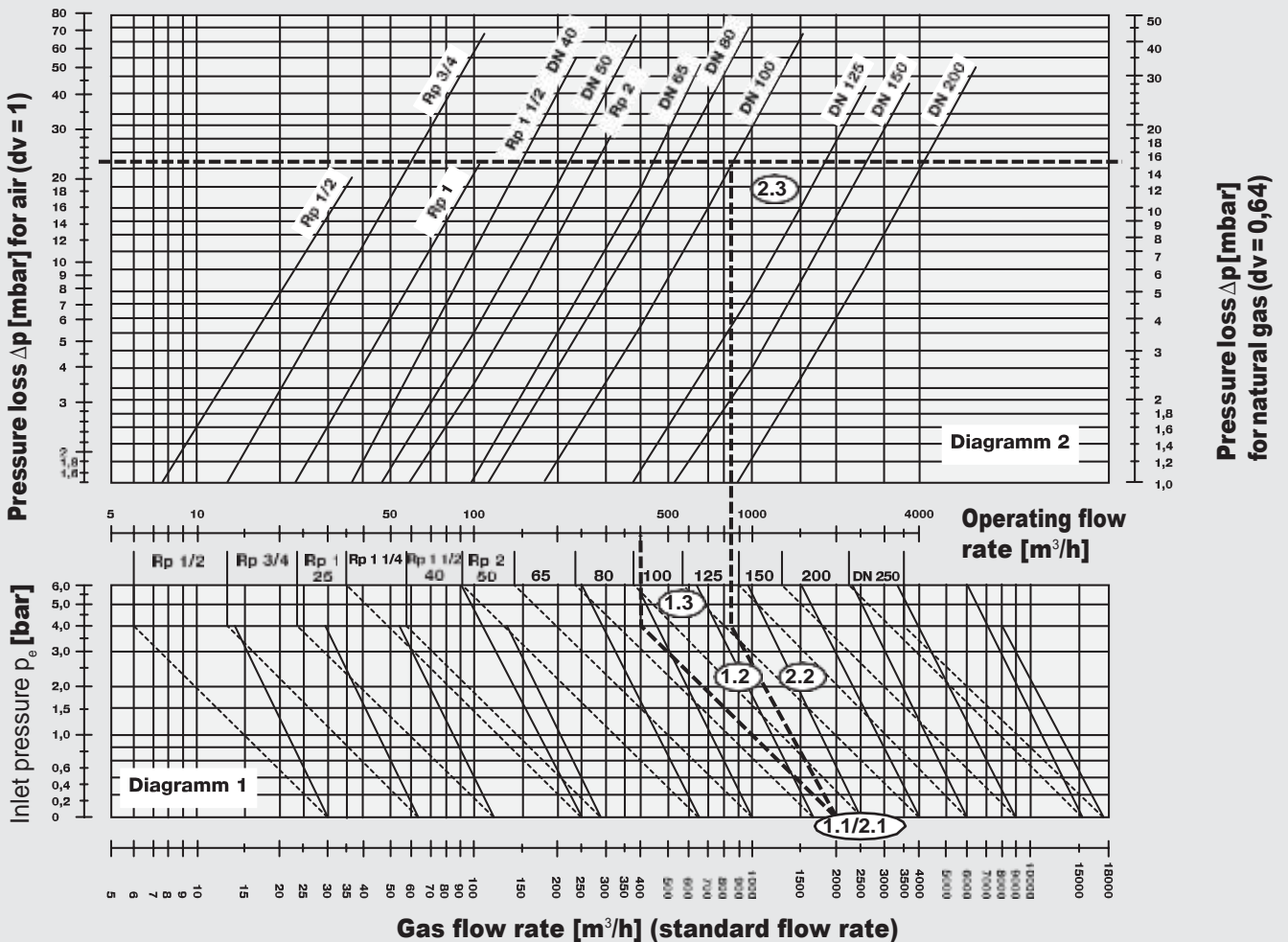



44 ซ.บรมราชชนนี 70 ถ.บรมราชชนนี ศาลาธรรมสพน์ ทวีวัฒนา กทม. 10170.  
website: <https://www.add-furnace.com/> โทร: 02-888-3472  
Line ID: @add11 e-mail: add028883472@gmail.com