



Manually operated safety shut-off valve

HSAV HSAV/5

DUNGS[®]
Combustion Controls

6.23



Technical description The DUNGS manual operated shut-off valve HSAV, HSAV/5 is semi-automatic as per EN 161 for gas burners and gas appliances.

- Max. operating pressure: 500 mbar / 50 kPa (HSAV/5) or 1.5 bar / 150 kPa (HSAV)
- Class A, Group 2 as per EN 161
- normally closed
- Fast closing
- manual opening only when operating voltage applied
- DC solenoid, rectifier wiring with radio interference suppression in terminal box
- Mountable closed position signal contact to monitor closed position of valve
- Tube thread as per ISO 7/1
- Flange connection as per DIN EN 1092-1
- Reliable function, rugged and maintenance-free

Application

The DUNGS manual operated shut-off valve HSAV... is suitable for gases of families 1, 2, 3 and other neutral gaseous media. The manual operation shut-off valve is used for shut-off and release of gas supply to gas burners and gas appliances. The shut-off valve can only be opened manually when the operating voltage is applied.

Approval

EC type testing certificate as per:

- EC-Gas Appliances Regulation

Approvals in other important gas consuming countries.



HSAV Single-stage solenoid valve, normally closed. Manually opening with operating voltage applied, fast closing.

HSAV/5 Single-stage solenoid valve, normally closed. Manually opening with operating voltage applied, fast closing. Closed position signal contact mountable.

Specifications

Nominal diameters	DN	65	80	100	
Pipe thread as per ISO /71	Rp	3/4	1	1 1/2	2
Flange	Connection flange (PN 16) as per DIN EN 1092-1				
Max. operating pressure	HSAV/5: 500 mbar (50 kPa), HSAV: 1.5 bar (150 kPa)				
Solenoid valve	Valve as per EN 161, Class A, Group 2				
Closing time	< 1 sec				
Opening	Manual, when operating voltage applied				
Materials of gas-conveying parts	Housing:	aluminium, steel, brass			
	Seals:	NBR basis			
Ambient temperature	-15°C to +60°C				
Installation position	Solenoid from vertically upright to horizontally lying - refer to operating and mounting instructions				
Dirt trap	Sieve installed, mesh width 1 mm				
Measuring/ignition gas connection	G 1/4 ISO 118, on both sides in inlet section, additionally G 3/4 on inlet side, from size DN 65 (flange) upwards				
Voltage/frequency	50-60 Hz, 230 V AC, -10% +15%, further voltages on request				
Rating / power consumption	See type overview				
Switch-on duration	100 %				
Degree of protection	IP 54, IP 65 on request				
Electrical connection	At screw terminals via PG 11 cable entry Plug connection as per DIN EN 175 301-803, can be retrofitted				
Closed position signal contact	Type K01/1 (DIN-tested), mountable on HSAV 5.../5				
Accessories	K01 closed position signal contact, see Datasheet 12.01			211 202	
	Equipment plug for line socket as per DIN EN 175 301-803			215 733	



บริษัท เอดีดี เฟอร์เนส จำกัด

ADD FURNACE CO.,LTD.

44 ซอยบรมราชชนนี 70 ถนนบรมราชชนนี แขวงศาลาธรรมสพน์ เขตทวีวัฒนา กรุงเทพฯ 10170

โทร: 02-888-3472 โทร: ออกแบบ:08-08-170-170 แฟกซ์: 02-888-3258

<https://www.add-furnace.com> E-mail: sales@add-furnace.com

Dimensions

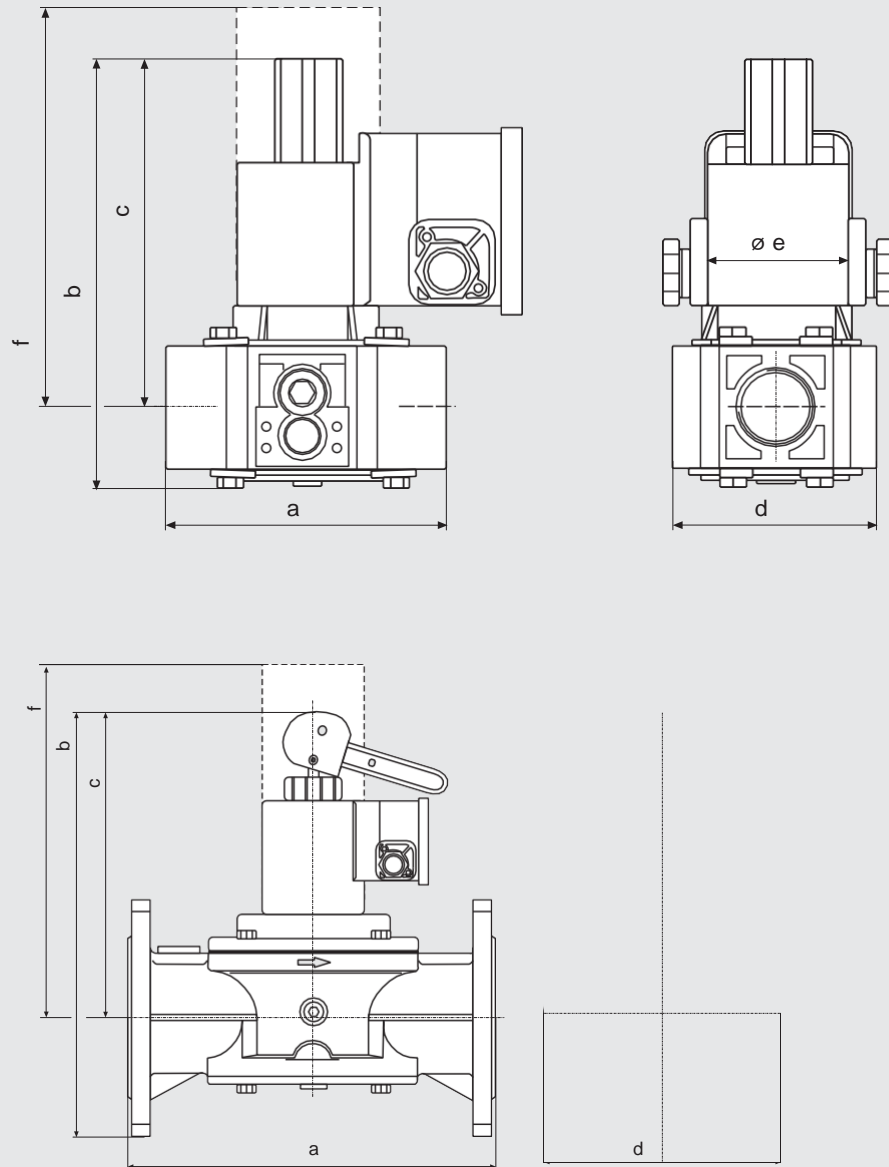

Type	DN / Rp	Order No.	p _{max.} [mbar]	P _{max.} [VA]	I _{max.} ~(AC) 230 V	Opening time	Dimensions [mm]					Weight [kg]	
							a	b	c	d	e		f
HSAV 1507	Rp 3/4	195 090	1500	15	0.08	< 1 s	100	145	120	73	50	170	1.3
HSAV 510/5	Rp 1	151 440	500	6	0.03	< 1 s	110	150	120	85	50	170	1.5
HSAV 515/5	Rp 1 1/2	155 790	500	9	0.05	< 1 s	150	200	160	110	60	250	2.5
HSAV 520/5	Rp 2	155 800	500	10	0.06	< 1 s	170	210	165	125	75	270	3.5
HSAV 5065/5	DN 65	155 810	500	20	0.11	< 1 s	290	325	235	185	80	350	8.0
HSAV 5080/5	DN 80	155 820	500	35	0.16	< 1 s	310	330	245	200	95	360	11.4
HSAV 5100/5	DN 100	155 830	500	60	0.28	< 1 s	350	375	275	240	115	410	17.7



HSAV/5 sectional drawing

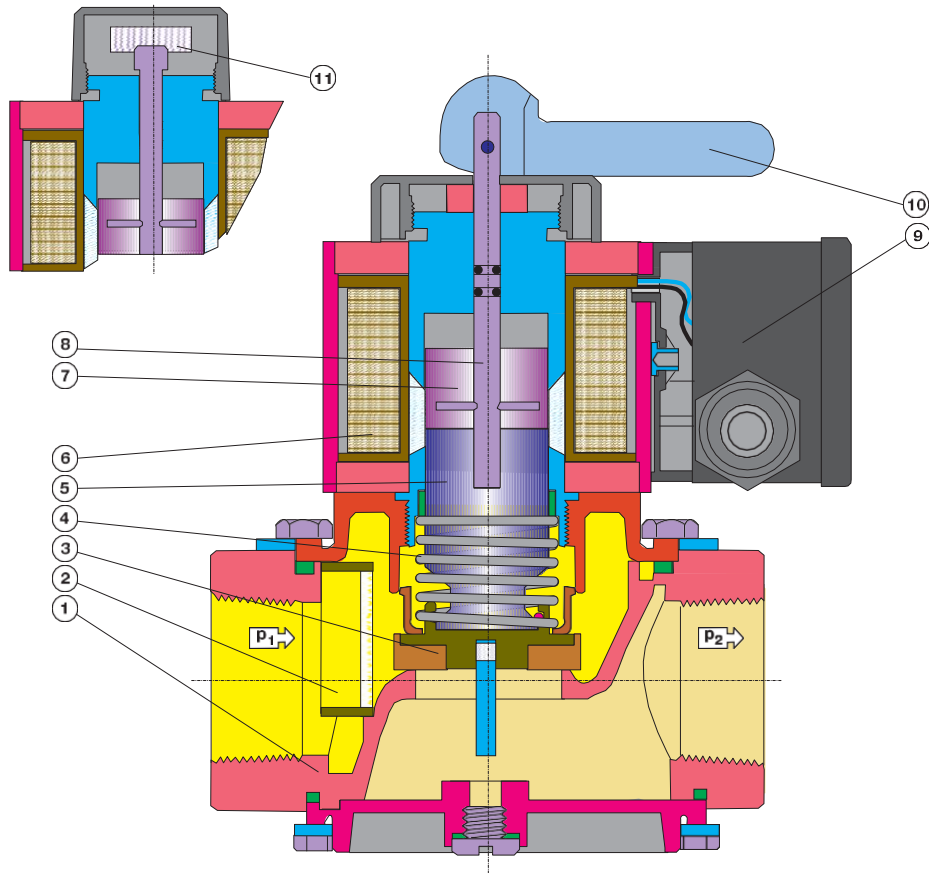

- | | | | | | |
|---|----------------|---|--------------------|----|----------------------------|
| 1 | Housing | 5 | Armature | 9 | Electrical connection |
| 2 | Sieve | 6 | Solenoid coil | 10 | Lever |
| 3 | Valve plate | 7 | Auxiliary armature | 11 | Knurled screw: on 507, 510 |
| 4 | Closing spring | 8 | Tension rod | | |

Technical description
 The DUNGS manual operated shut-off valve is semi-automatic, operated with auxiliary power. The electromagnetic drive opens against the force of the closing spring 4 only with manual action.

If the auxiliary power is interrupted (operating voltage), closing spring 4 closes the valve within 1 second. If gas supply is interrupted and auxiliary power is applied again, the shut-off valve does not open automatically.

The closing function cannot be impaired externally. The closed position of the valve can be monitored by a mountable closed position signal contact.



Setup

HSAV 1507, HSAV 510/5

1. Remove protection cap.
2. Set knurled nut into closed position.
3. Switch on voltage.
4. Set knurled nut to open position by pulling.

When voltage is applied, the HSAV remains open.

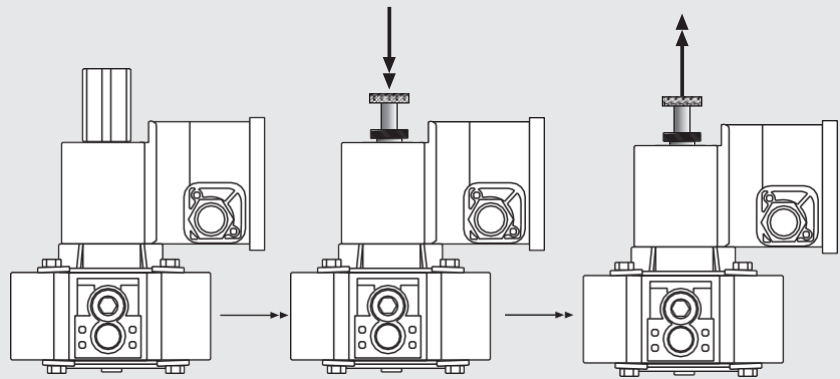

Setup

HSAV 515/5 - HSAV 520/5, HSAV 5065/5 - HSAV 5100/5

1. Remove locking pin.
2. Swivel lever through 180°.
3. Apply voltage.
4. Swivel lever through 180° again.
5. Push locking pin through hole.

When voltage is applied, the HSAV remains open.

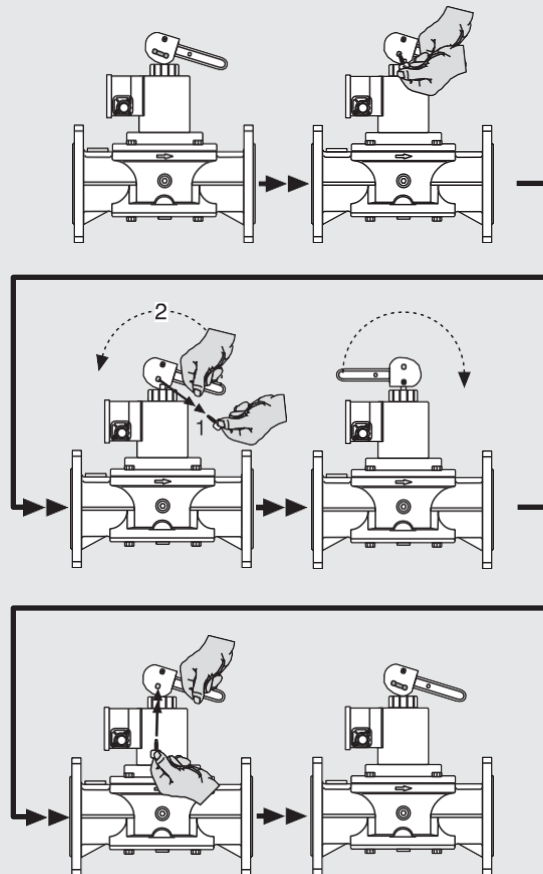



บริษัท เอดีดี เฟอร์เนส จำกัด

ADD FURNACE CO.,LTD.

44 ซอยบรมราชชนนี 70 ถนนบรมราชชนนี แขวงศาลาธรรมสพน์ เขตทวีวัฒนา กรุงเทพฯ 10170

โทร: 02-888-3472 โทร: ออกแบบ:08-08-170-170 แฟกซ์: 02-888-3258

https://www.add-furnace.com E-mail: sales@add-furnace.com

Manually operated
safety shut-off valve
HSAV
HSAV/5

DUNGS®
Combustion Controls

Flow diagram

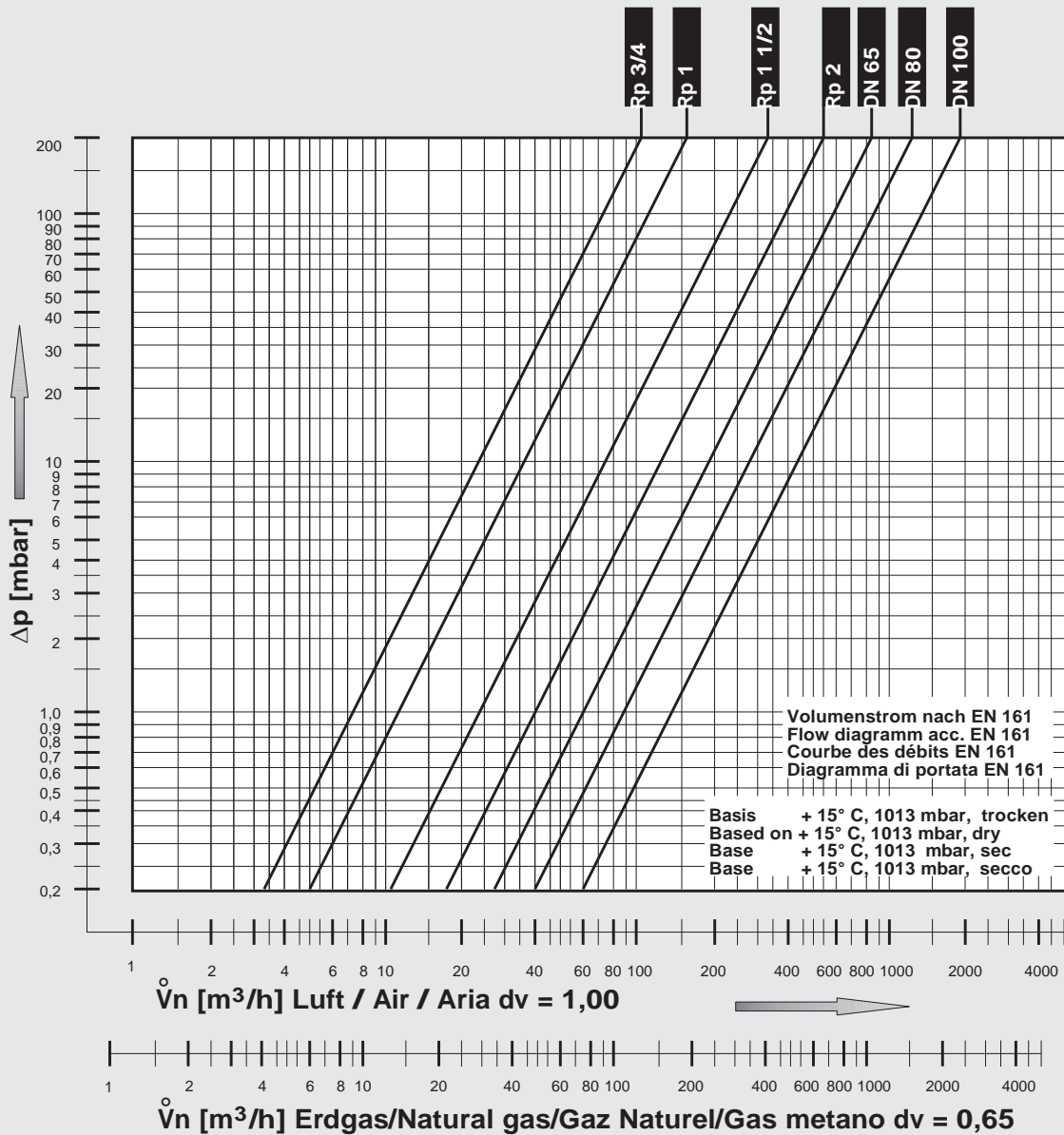

We reserve the right to make any changes in the interest of technical progress.