



Pressure regulator FRU Circulation regulator

4.12

DUNGS[®]
Combustion Controls



Technical description

The DUNGS pressure regulator, type FRU, is a circulation regulator with adjustable setpoint spring. The pressure regulator complies with EN88-1.

- Input pressures up to 150 mbar (15 kPa)
- High flow rate
- Sturdy, precise and sensitive regulation of regulator input pressure (response pressure)
- Inlet pressure compensation diaphragms
- Safety diaphragms
- External pulse as standard
- Rp 1/2 - Rp 2 threaded connection
- DN 40 - DN 100 flange connection

Application

The DUNGS pressure regulator, type FRU, limits the output pressure of a booster to the set value (response pressure) when consumption fluctuates. It does not contain any non-ferrous metals and is suitable for gases up to max. 0.1 vol.% H₂S, dry. Suitable for gases of families 1, 2, 3 and other neutral gaseous media.

Approval

EC type testing certificate as per:

- EC-Gas Appliances Regulation

FRU ... CE-0123CU1023

Approvals in other important gas consuming countries.



FRU Spring-loaded pressure regulator fitted with adjustable setpoint spring. Prepared for external pulse of regulator input pressure (blower output pressure). Suitable for limiting the regulator input pressure for blower-supported gas equipment in the range above atmospheric pressure.

Specifications

Nominal diameters	DN	40	50	65	80	100
Pipe thread as per ISO 7/1	Rp	1/2	3/4	1	1 1/2	2
Flange	Connection flange (PN 16) as per DIN EN 1092-1 up to					
Max. operating pressure	500 mbar (50kPa)					
regulator	Pressure regulator as per EN 88-1, Class A, Group 2 up to					
Input pressure range	150 mbar (15kPa)					
Response pressure range	5 mbar (0.5 kPa) to 150 mbar (15 kPa) as a factor of adjustable setpoint spring					
Materials of gas-conveying parts	Housing: aluminium, steel Seals and diaphragms: NBR					
Ambient temperature	-15 °C to +70 °C					
Installation position	Regulator dome from vertically upright to lying horizontally G 1/4					
Measuring/ignition gas connections	ISO 228 on both sides in inlet section					
Pulse connection	External, prepared for connection of response pressure					
Blow-off line selection	Spring Blow-off line need not be routed, safety diaphragms are installed The desired response pressure is provided by the force of the installed adjustable spring. The pressure regulator is equipped with a blue spring (No. 4) as standard. If other pressure ranges need to be covered, select the spring required as specified in the table below.					

Guiding range in mbar	5 - 9	5 - 13	5 - 20	10 - 30	25 - 55	30 - 70	60 - 110	100 - 150
Spring colour	Spring 1	Spring 2	Spring 3	Spring 4	Spring 5	Spring 6	Spring 7	Spring 8
Nominal diameter Rp/DN	brown	white	orange	blue	red	yellow	black	pink
Rp 1/2	229 817	229 818	229 820	229 821	229 822	229 823	229 824	229 825
Rp 3/4	229 833	229 834	229 835	229 836	229 837	229 838	229 839	229 840
Rp 1	229 842	229 843	229 844	229 845	229 846	229 847	229 848	229 849
Rp 1 1/2	229 851	229 852	229 853	229 854	229 869	229 870	229 871	229 872
Rp 2	229 874	229 875	229 876	229 877	229 878	229 879	229 880	229 881
DN 65, 80	229 883	229 884	229 885	229 886	229 887	229 888	229 889	229 890
DN 100	229 892	229 893	229 894	229 895	229 896	229 897	229 898	229 899

Pressure taps

- 1 Breathing plug
- 2 Connection for external pulse G 1/4 ISO 228 screw plug on both sides
- 3 G 1/8 or G 1/4 ISO 228 screw plug in inlet section on both sides (see type summary)

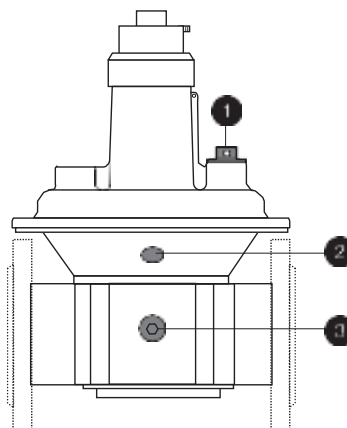



Dimensions [mm]

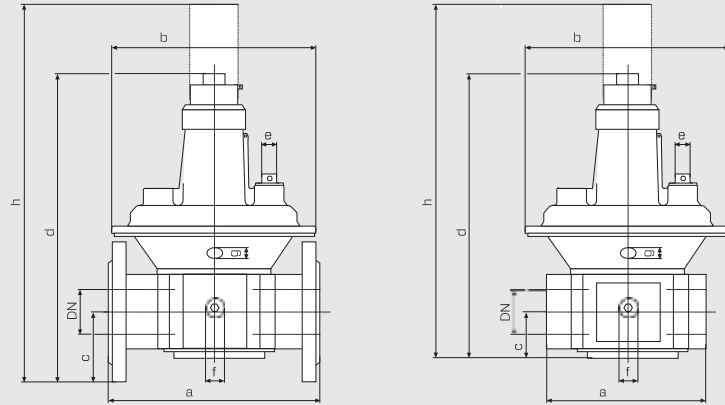

Type	Order No.	p _{max.} [mbar]	Rp / DN	Dimensions [mm]								Weight [kg]
				a	b	c	d	e	f	g	h	
FRU 505	221 928	500	Rp 1/2	77	115	24	143	G 1/4	G 1/8	G 1/8	225	0.60
FRU 507	221 929	500	Rp 3/4	100	130	28	165	G 1/4	G 1/8	G 1/8	245	1.00
FRU 510	169 130	500	Rp 1	110	145	33	190	G 1/4	G 1/8	G 1/8	310	1.20
FRU 515	178 900	500	Rp 1 1/2	150	195	40	250	G 1/2	G 1/4	G 1/4	365	2.50
FRU 520	178 910	500	Rp 2	170	250	47	310	G 1/2	G 1/4	G 1/4	450	3.50
FRU 5040	178 930	500	DN 40	200	195	75	280	G 1/2	G 1/4	G 1/4	395	3.50
FRU 5050	178 940	500	DN 50	230	250	82.5	340	G 1/2	G 1/4	G 1/4	480	5.00
FRU 5065	178 950	500	DN 65	290	285	92.5	405	G 1/2	G 1/4	G 1/4	590	7.50
FRU 5080	160 910	500	DN 80	310	285	100	405	G 1/2	G 1/4	G 1/4	590	10.00
FRU 5100	178 960	500	DN 100	350	350	110	495	G 1/2	G 1/4	G 1/4	760	16.00

Application example
FRU circulation regulator in gas
pressure booster system

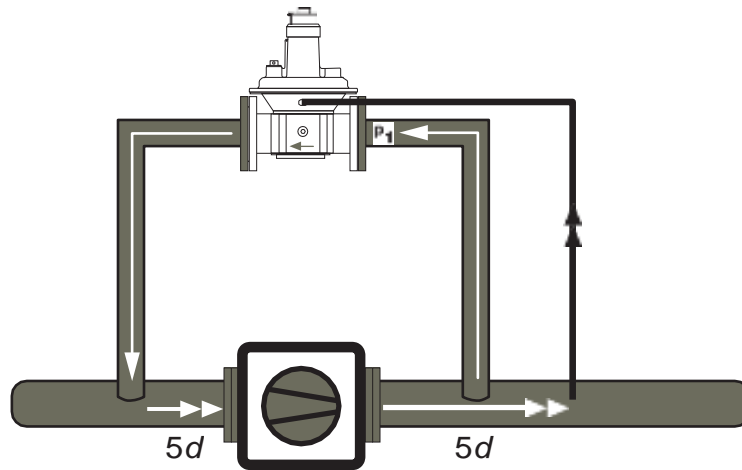

The FRU gas pressure regulator constantly limits the pressure in a gas-consuming system. In the system, the gas supply pressure is increased to a higher pressure

by a gas blower (pressure increasing device). If the generated pressure exceeds the set response pressure, the FRU pressure regulator opens.

The output pressure of the pressure booster is relieved via the return line.

! Pulse line between pressure regulator and blower outlet must not be lockable. Pulse line against pressure increase. must be made of PN 1 steel (min. DN 6). Keep pulse line short and route safely to prevent deformation and cracks.

! Connect pulse line in inlet section to protect gas equipment

! Do not close breathing plug. Connection to ambient pressure must exist.



Pressure regulator
FRU
Circulation regulator



Flow diagram

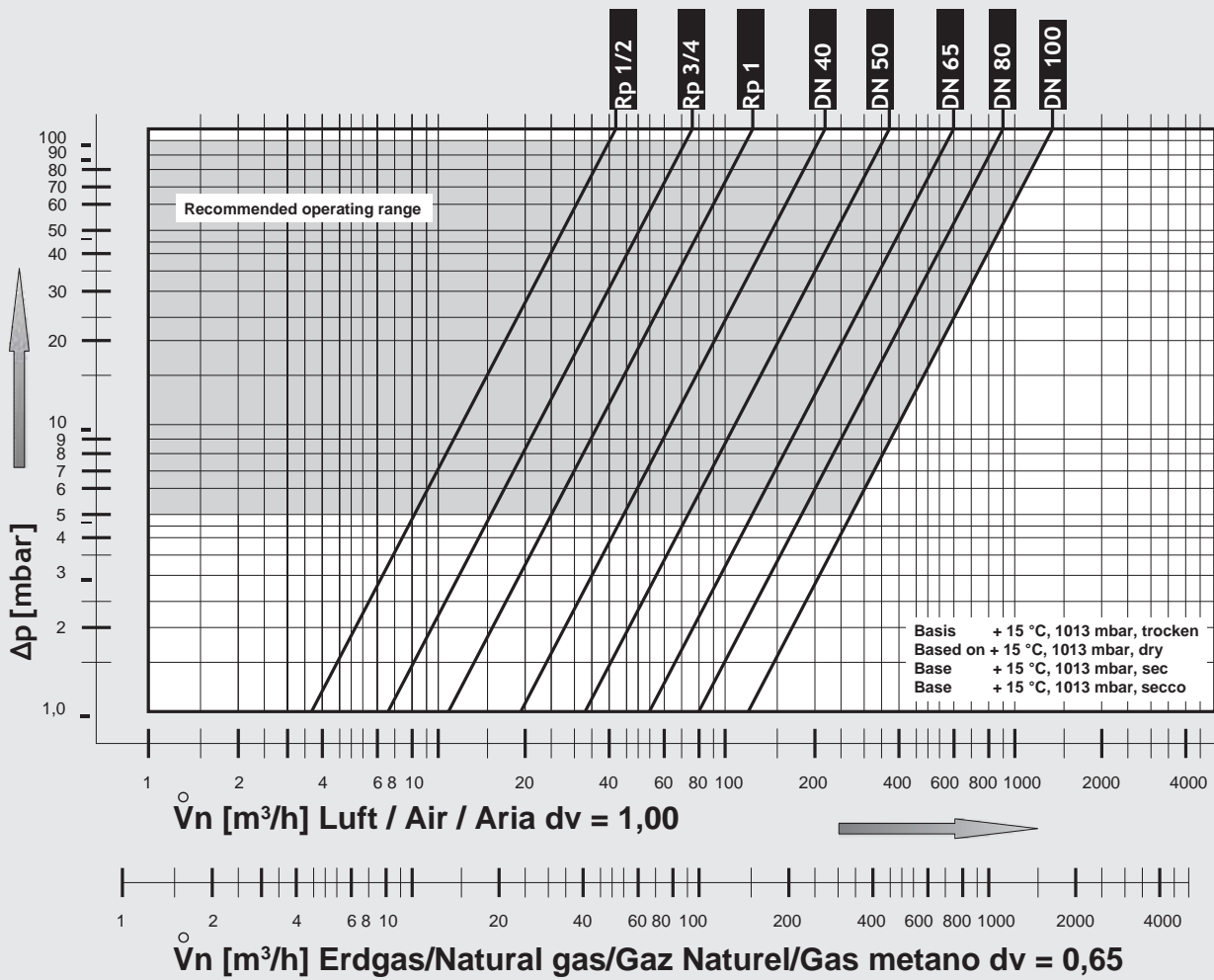

We reserve the right to make any changes in the interest of technical progress.