



Control unit for system leakage tests

Type VPM-VC

(Valve Check)

8.22

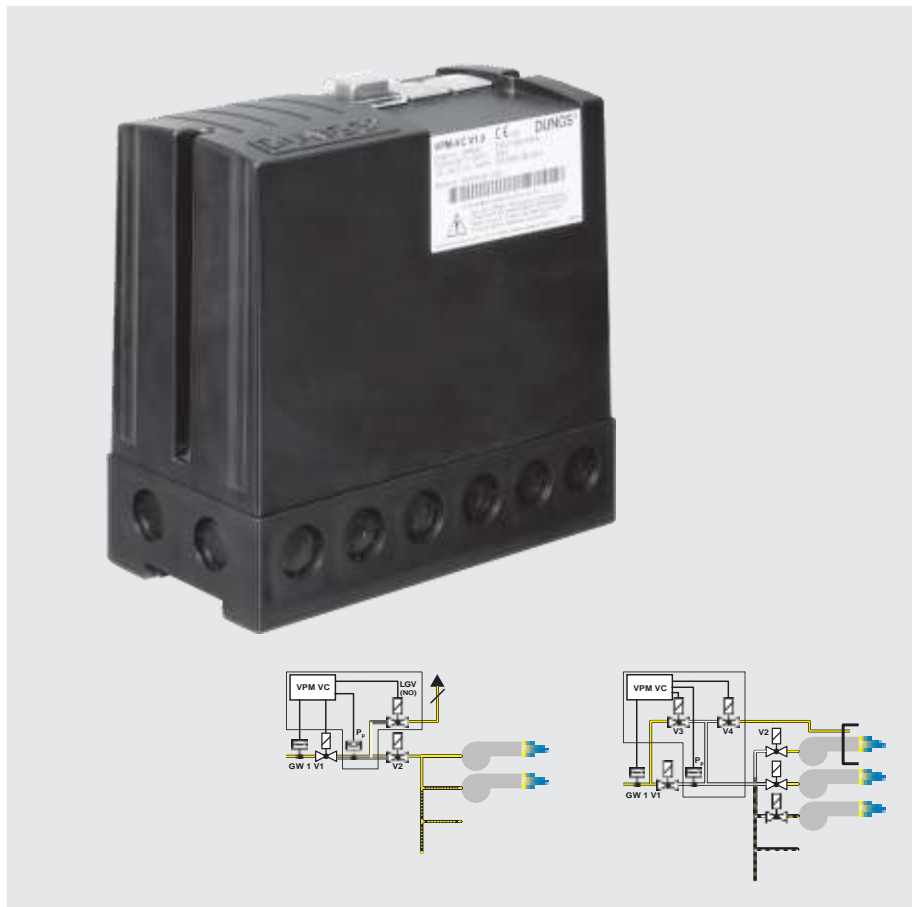

Description

The VPM-VC valve test module checks the tightness of burner gas shut-off valves in combination with one or two pressure switches. The test is performed in accordance with EN 1643.

The program sequence, filling and venting parameters as well as program times can be adjusted by the user according to the system requirements.

Application

The VPM-VC has been designed for automatic leak testing between two solenoid valves in gas-consuming devices, either prior to start-up or after switching off the system. The test system can be used as a single leakage tester or in combination with

automatic burners. It is used in gas burner systems for heating, process heating, process industry and gas engines.

Approvals

- EU type testing certificate as per:
 - EU-Gas Appliances Regulation
 - EU-Pressure Equipment Directive

The VPM meets the requirements of:

- Machinery Directive 2006/42/EC
- Low Voltage Directive 2014/35/EU
- EMV 2014/30/EU

Approvals in other important gas-consuming countries.
FM Approvals Class 7610

**VPM-VC**

Control unit for system leakage tests according to En 1643.

Checks tightness of the gas burner shut-off valves either before burner start or after shutdown.

Equipment: one or two gas pressure switches.

Additional pilot valves are required depending on the system



Pressure switches/valves/pilot valves are not part of the scope of delivery!

Technical data

Rated voltage (depending on the model)	~ (AC) 230 V +10 % / -15 % 50-60 Hz ±5 % ~ (AC) 115 V +10 % / -15 % 50-60 Hz ±5 %
Power consumption	max. 10 W
Power consumption Typical	115 V: standby 2.6 W operation 4.6W 230 V: standby 3.1W operation 5.4W
Backup fuse L1	6.3 A T (10 A F), integrated, replaceable
Humidity	DIN 60730-1, no dewing admissible
Type of protection	IP 42
Ambient temperature	-20 °C to +60 °C
Storage temperature	-40 °C to +80 °C
Switch-on duration	100 %
Operational altitude	Suitable for use up to 2000 metres above sea level
Test volume	Unlimited
Medium	Any; gas type depending on pressure switch and valve
Inlet pressure	Any; depending on pressure switch and valve
Multifunction output (MFA)	Number of operating cycles V1 > 100.000 (terminal 19 + 20, potential-free). Further settings possible via VisionBox + parameter change: 1. Freely selectable number of operating cycles up to 6.5 million (standard 100,000) 2. Signal output with freely selectable number of operating cycles of V2, LGV or release 3. Signal output while the test is running or while voltage is applied 4. Signal after successful switch-off
Program sequence can be selected	Three different program sequences can be selected via DIP switches: 1. Valve test before burner start 2. Valve test after burner switch-off 3. Test sequence with optimised valve operating cycles after burner switch-off without additional switching cycles. In this case, only one valve will be tested at a time after successful switch-off, --> lower power consumption and increased valve life.
Test times can be set	DIP switches can be used to select predefined test times of V1 and V2, enabling optimal setting in case of different test volumes, inlet pressures and leakage rates. Alternatively, individual test times, even different times for V1 and V2, can be set via VisionBox.
Filling and venting attempts	Depending on the test volume, different combinations can be selected using DIP switches.
Signalling for V1 and V2	Red/green LEDs signal various information on the program and release states or error codes.
TWI interface	Plug-in connection for DUNGS VisionBox. The VisionBox can be used to access the VPM via a PC. The VisionBox is hardware and software for VPM parameter setting. Status information and error error memory data can be read out.
Mounting position	As desired



Application information	
EN 676: 2008-11	... requests tightness checks at burner capacities above 1,200 kW or already at capacities from 70 kW for burners without pre-purging.
EN 746-2: 2011-02	...requests the use of a VPM for some applications. Pre-venting of the burner chamber can be omitted when using a VPM. Venting of the furnace is done to the atmosphere.
EN 1643: 2001-02	...in combination with a VPM, venting may be done into the furnace for max. 3s.

Wiring scheme	Outputs		Electrical data	
<p>The sum of the currents of all safety-related consumers must not exceed 5 A! The sum of the currents of all consumers must not exceed 6.3 A (10 A).</p>	11		Release 115/230 VAC / 5 A cos $\phi = 1$ Minimum load 0.5 W	
	6		V1 115/230 VAC / 2 A cos $\phi = 1$ Minimum load 0.5 W	
	8		V2 115/230 VAC / 2 A cos $\phi = 1$ Minimum load 0.5 W	
	10		LGV 115/230 VAC / 2 A cos $\phi = 1$ Minimum load 0.5 W	
	16 17		External fault 115/230 VAC / 1 A cos $\phi = 1$	
	19		MFA 115/230 VAC / 1 A cos $\phi = 1$	
		Inputs		Electrical data
	4	TR	Test request 115/230 VAC	
	13		Pp1 115/230 VAC (NO)	
	14		Pp2 115/230 VAC (NC)	
12		Remote unlocking 115/230 VAC		
7		V1_In 115/230 VAC		
9		V2_In 115/230 VAC		

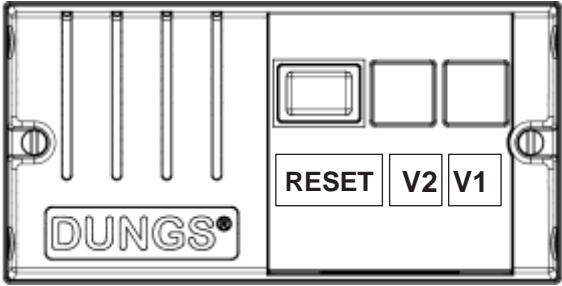

Signalling unit		Error information			
		<div style="border: 1px solid black; width: 40px; height: 40px; display: flex; align-items: center; justify-content: center; margin: 0 auto;"> V2 </div>	<div style="border: 1px solid black; width: 40px; height: 40px; display: flex; align-items: center; justify-content: center; margin: 0 auto;"> V1 </div>	Detailed error information via flash codes All LEDs are flashing: <ul style="list-style-type: none"> when a key press is requested during a level change when the VPM is ready for extended unlocking 	
		MFT (RESET) = multifunction switch: Unlocking switch for error status ...max. 5x/15 min. Changeover switch to switch to the password-protected function level for service and OEM parameter setting via TWI interface by means of the VisionBox.	V2 two LEDs green / red	V1 two LEDs green / red	Off Constantly red Red flashing 1x Red flashing 2x Red flashing 3x Red flashing 4x Red flashing 5x Constantly red Constantly green
		Switch-on (mains): All LEDs light up as a functional test for approx. 1.5 s. Waiting for test request: Green LED's flashing slowly (4 s off, 0,125 s on). Depending on the states, the LED-V1 and LED-V2 indicators are flashing or lit constantly			



Modification of the program sequence by an application-specific setting of the B/C DIP switches

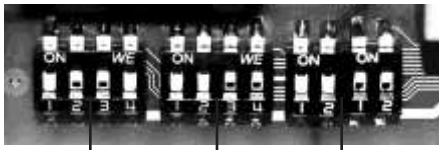

AAAA

BBBB

CCCC

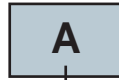

0000



0000

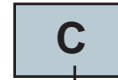

0000

A Test sequence		B t_{test} V1, V2 test time		C Number of venting or filling attempts	
1100	Test during the start phase before burner ignition	1100	10 s	1100	Venting 10 (1) Filling 1
		0110	22 s	0110	Venting 1 Filling 1
		1001	30 s	1001	Venting 1 Filling 10
1001	Test after regular shutdown	0011	55 s The following can be changed via the software: P22 for test time V1 P23 for test time V2 If this switch position is used, parameter setting should be checked via the VisionBox.	0011	Venting 3 (1) Filling 3 (1) The following can be changed via the software: P32: Number of venting operations P31: Number of filling operations If this switch position is used, parameter setting should be checked via the VisionBox.
0011	Test after regular shutdown in reduced mode without additional operating cycles Operating mode "T- Down optimised": after regular switch-off, one valve is tested at a time alternatively, the other valve is kept open. The alternation takes place during release, when removing the test request next time. - burner with frequent starts - longer valve life - reduced power consumption	t_{test}	For the calculation of the test times, see p. 7 Setting must be higher than the calculated time. $t_{DIP} > t_{test V1} , t_{test V2}$	(1) 	For more detailed explanations, see installation examples in the VPM-VC operating and mounting instructions. According to EN1643, 1 filling or 1 emptying attempt for max. 3 s into the burner chamber is admissible (DUNGS as-delivered configuration). At filling and emptying times of 1 s of the gas main valves, max. 3 attempts are admissible. If the number of venting attempts is higher, venting must be into a safe area (LGV vent valve).



Installation examples	
	The functional principle must be selected in accordance with the local regulations
	Prevent soiling by using appropriate gas filters
	Use of pilot valves recommended

Please note: Switch positions (1), (2), (3), (4)	
(1)	According to EN1643, 1 filling or 1 emptying attempt for max. 3 s into the burner chamber is admissible (DUNGS as-delivered configuration). At filling and emptying times of 1 s of the gas main valves, max. 3 attempts are admissible.
(2)	When filling or emptying attempts are carried out via pilot valves, the situation described in Ä, shows that the specifications of EN1643 are also met with 10 filling or emptying attempts if pilot valves are used that can reach at most only 1/10 of the maximum gas flow of the main valves.
(3)	If the valve check is carried after a regular shutdown, the system setup must ensure that locking the system prevents a valve check during a fault situation. This can only be achieved by safe interruption of the power supply to the VPM when a fault occurs.
(4)	If this switch position is used, parameter setting should be checked via the VisionBox.

1a Direct valve check via LGV, venting through roof	
--- Valve check system component: VPM-VC, Pp, LGV	
DIP-mode: A: 1100 1001 (3) 0011 (3), (4) B: xxxx C: 1100 0110 0011 (1), (4) Parameter: ---	
1b Direct valve check via V4, venting into the burner chamber	
--- Valve check system component: VPM-VC, Pp, V4	
DIP-mode: A: 1100 1001 (3) 0011 (3), (4) B: xxxx C: 1100 (2) 0110 0011 (1), (4) Parameter: ---	

Notes regarding 1a, 2:

If a valve closed when not powered is replaced instead of a LGV (open when not powered), it must be connected to output V2 (terminal 8).



<p>2 ...</p>	<p>Valve check via pilot valves V3, LGV venting through the roof Valve check system component: VPM-VC, Pp, V3, LGV</p>	<p>DIP mode: A: 1100 1001 (3) 0011 (3), (4) B: xxxx C: 1100 0110 1001 (2) 0011 (2), (4) Parameter: ---</p>
<p>3 ...</p>	<p>Direct valve check Valve check system component: VPM-VC, Pp</p>	<p>DIP mode: A: 1100 1001 (3) 0011 (3), (4) B: xxxx C: 0110 0011 (1), (4) Parameter: ---</p>
<p>4 ...</p>	<p>Direct valve check via pilot valves, venting into the burner chamber Valve check system component: VPM-VC, Pp, V3, V4</p>	<p>DIP mode: A: 1100 1001 (3) 0011 (3), (4) B: xxxx C: 1100 (2) 0110 1001 0011 (2), (4) Parameter: ---</p>



<p>5a</p> <p>...</p>	<p>Valve check via pilot valves, venting to V2 via LGV_{Type2} (normally closed)</p> <p>Valve check system component: VPM-VC, Pp, LGV_{Type2} (NC)</p> <p>The LGV type 2 is required for opening the gas flow behind V2 (to the burner chamber or atmosphere), allowing it to be emptied when V2 is deliberately (during the test) open. The pressure behind V2 must be able to escape, since otherwise V2, as response to "No gas pressure", allows gas to pass in the reverse direction during the test time, if there is still pressure behind V2. This allows the pressure to drop in the monitored interspace if V2 is leaking. During release (automatic burner control is working), the LGV type 2 is closed.</p>		<p>DIP mode: A: 1100 1001 (3) 0011 (3), (4) B: xxxx C: 1100 0110 0011 (1), (4) Parameter: P12 = 1</p>
<p>5b</p> <p>...</p>	<p>Valve check via pilot valves, venting to V2 via LGV_{Type2} (normally closed) into the burner chamber</p> <p>Valve check system component: VPM-VC, Pp, LGV_{Type2} (NC)</p> <p>The LGV type2 is required for opening the gas flow behind V2 (to the burner chamber or atmosphere). This allows the pressure to drop in the monitored interspace if V2 is leaking. Emptying takes place via LGV. During release (automatic burner control is working), the LGV and the LGV-type 2 are closed.</p>		<p>DIP mode: A: 1100 1001 (3) 0011 (3), (4) B: xxxx C: 1100 0110 0011 (1), (4) Parameter: P12 = 1</p>



บริษัท เอดีดี เฟอร์เนส จำกัด

ADD FURNACE CO.,LTD.

44 ซอยบรมราชชนนี 70 ถนนบรมราชชนนี แขวงศาลาธรรมสพน์ เขตทวีวัฒนา กรุงเทพฯ 10170

โทร: 02-888-3472 โทร: ออกแบบ:08-08-170-170 แฟกซ์: 02-888-3258

https://www.add-furnace.com E-mail: sales@add-furnace.com

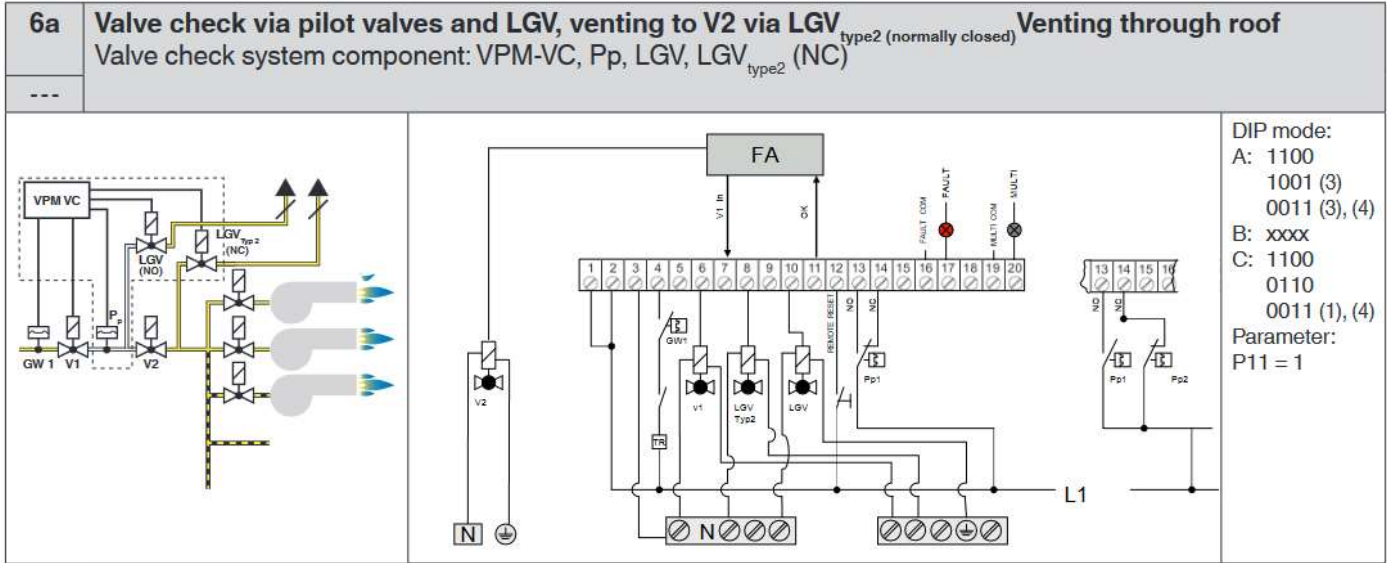



บริษัท เอดีดี เฟอร์เนส จำกัด

ADD FURNACE CO.,LTD.

44 ซอยบรมราชชนนี 70 ถนนบรมราชชนนี แขวงศาลาธรรมสพน์ เขตทวีวัฒนา กรุงเทพฯ 10170



โทร: 02-888-3472 โทร: ออกแบบ:08-08-170-170 แฟกซ์: 02-888-3258

<https://www.add-furnace.com> E-mail: sales@add-furnace.com

Control unit for system leakage tests

**Type VPM-VC
(Valve Check)**





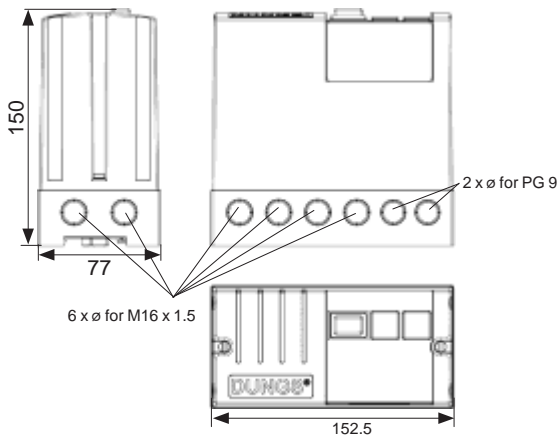

Version	Description	Order No.
Complete device 	VPM-VC cpl. 230 VAC	259 696
	VPM-VC cpl. 115 VAC	259 697
Top part 	VPM-VC 230 VAC	258 625
	VPM-VC 115 VAC	258 890
Base 	1 piece	259 694
	48 piece	259 695

Dimensions

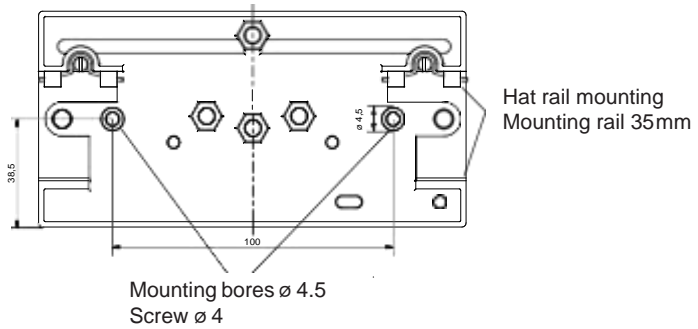

Installation



Accessories	
	<p>Gas pressure switch Depending on the operating pressure, see data sheets LGW...A4 (5.08) GW...A6 (5.01) GW...A4 HP (5.04)</p>
	<p>Pilot solenoid valves see data sheets DMV... (7.30, 7.37, 7.38), MV 502 (6.21) MVD ... (6.20)</p>
	<p>MPA VisionBox As addition to MPA parameterisation and service box for setting VPM parameters via a PC/laptop.</p>

Subject to technical modification in the interest of technical progress.