

Eclipse ThermJet

Burners

Model TJ0200

Version 2.7

Parameter	Burner Velocity		Model TJ0200
Maximum Input, Btu/h (kW)	Medium & High Velocity		2,000,000 (586)
Minimum Input On-Ratio, Btu/h (kW)	Medium & High Velocity		200,000 (59)
Minimum Input Fixed Air, Btu/h (kW)	Medium & High Velocity		40,000 (12)
Gas Inlet Pressure Required, "w.c. (mbar) Tap B (see page 3)	High Velocity	Natural Gas	9.3 (23.0)
		Propane	12.7 (32.0)
		Butane	13.4 (34.0)
	Medium Velocity	Natural Gas	7.1 (18.0)
		Propane	8.5 (21.0)
		Butane	6.9 (17.0)
Air Inlet Pressure Required, "w.c. (mbar) 15% Excess Air at Maximum Input Tap A (see page 3)	High Velocity	Natural Gas	12.3 (31.0)
		Propane	14.1 (35.0)
		Butane	14.1 (35.0)
	Medium Velocity	Natural Gas	10.0 (25.0)
		Propane	11.0 (28.0)
		Butane	11.0 (28.0)
High Fire Flame Length, inches (mm) Measured from the outlet end of the combustor	High Velocity	Natural Gas	34 (864)
		Propane	36 (914)
		Butane	36 (914)
	Medium Velocity	Natural Gas	38 (965)
		Propane	38 (965)
		Butane	38 (965)
Approximate Flame Velocity, ft/s (m/s) 15% Excess Air at Maximum Input	High Velocity		500 (152)
	Medium Velocity		330 (101)
Maximum Combustion Air Temperature	300°F (149°C). For higher temperatures use TJPCA (Datasheet 206).		
Flame Detection	Flame rods can be used with all alloy and SiC combustors, natural gas and operating temperatures up to 2,200°F (1,204°C). UV scanners can be used with all combustors, any fuel listed below, and up to the maximum operating temperature. Certain piping configurations prohibit the use of a flamerod, see page 3 for details.		
Fuel <i>For any other mixed gas, contact Eclipse, Inc.</i>	Natural gas, propane or butane ¹		
Approvals	 AN30		

1. See Design Guide 205 for more information about typical fuel composition and properties

- All information is based on laboratory testing in neutral (0 "w.c., 0 mbar) pressure chamber. Different chamber conditions may affect the data.
- All information is based on standard combustor design. Changes in combustor will alter performance and pressures.
- All inputs based upon gross calorific values and standard conditions; 1 atmosphere, 70°F (21°C).
- Eclipse reserves the right to change the construction and/or configuration of our products at any time without being obliged to adjust earlier supplies accordingly.
- Plumbing of air and gas will affect accuracy of orifice readings. All information is based on generally acceptable air and gas piping practices.

Performance Graphs

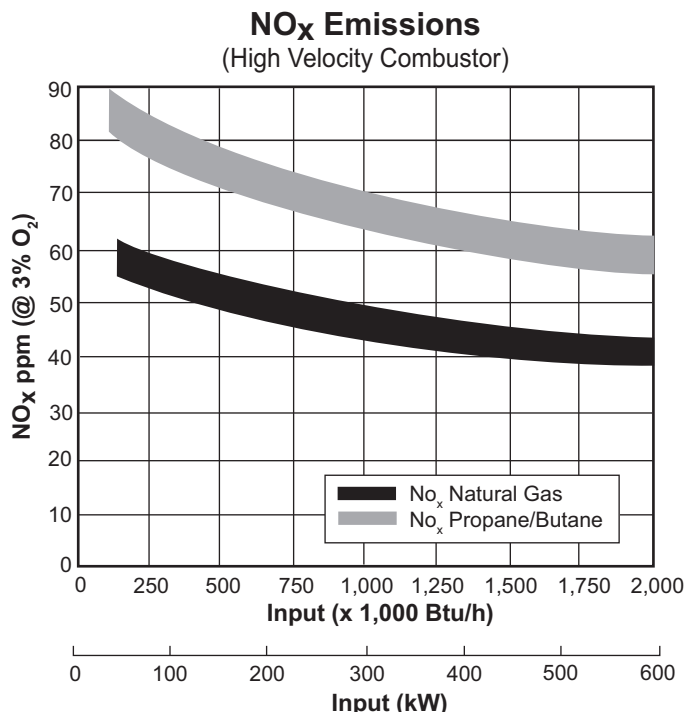
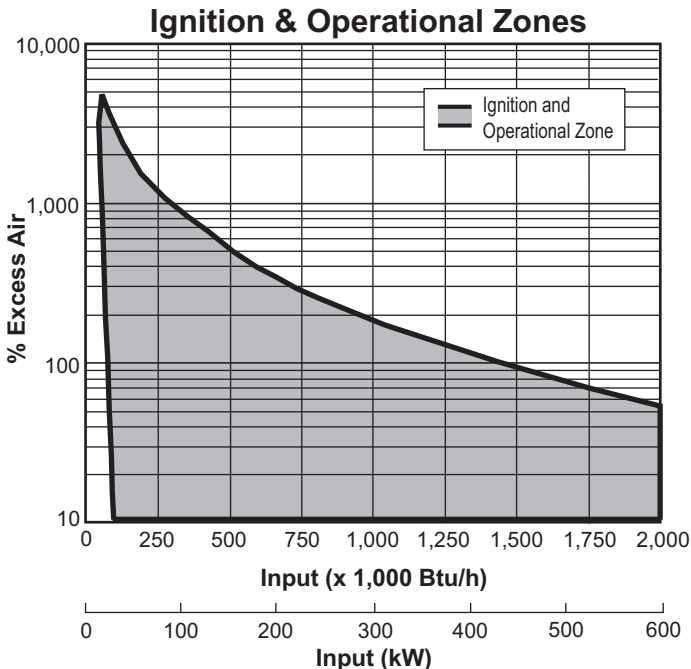

Emissions correction factor for medium velocity combustor is 1.20. Emissions data based on, on-ratio control firing at 15% excess air corrected to 3% O₂.

Emissions from the burner are influenced by:

- Fuel type
- Combustion air temperature
- Firing rate
- Chamber conditions
- Percent of excess air

For estimates of other emissions, contact Eclipse.

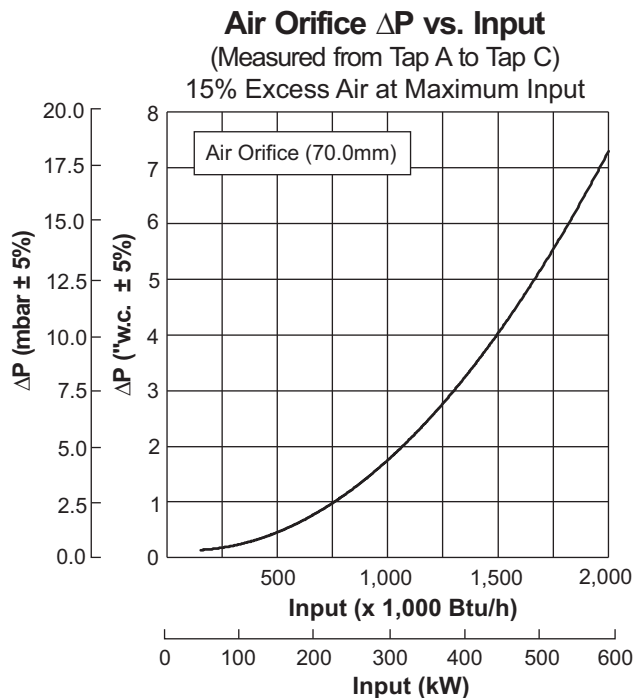
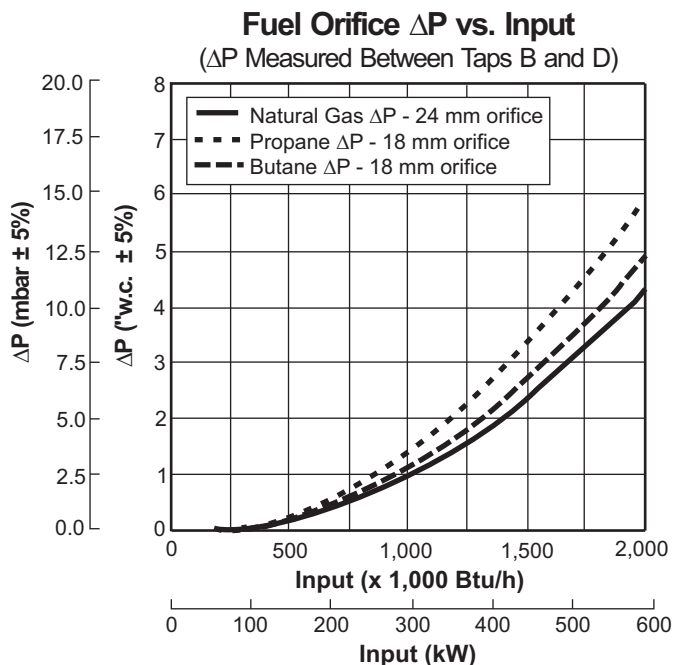

Dimensions and Specifications

Dimensions in mm (inches)

Burner Housing

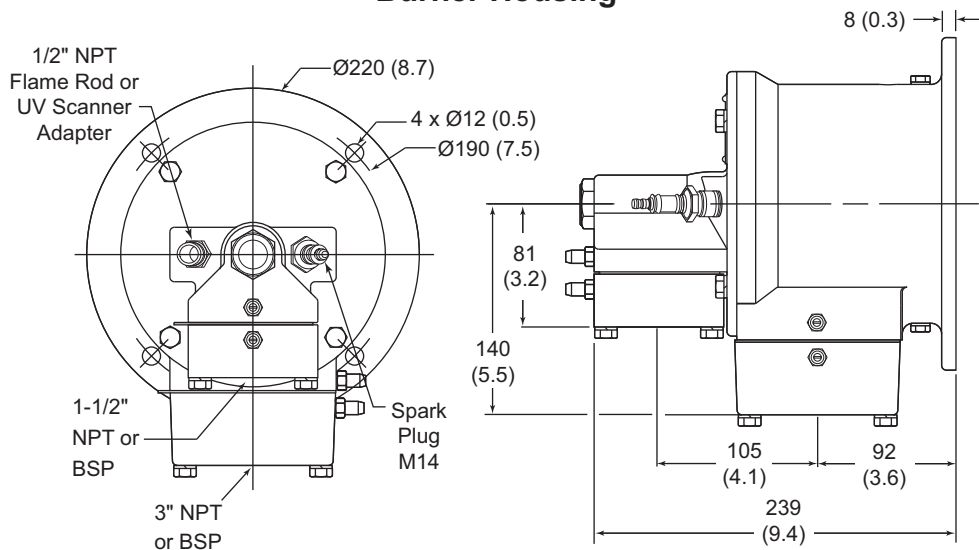

Burner weight less combustor: 42 lbs (19 kg)

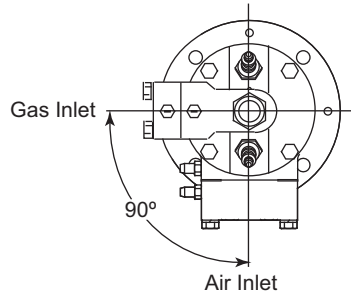

If using a flame rod, do not install the burner with the gas inlet at 0° or rotated 90° clockwise with respect to the air inlet

Tap Locations

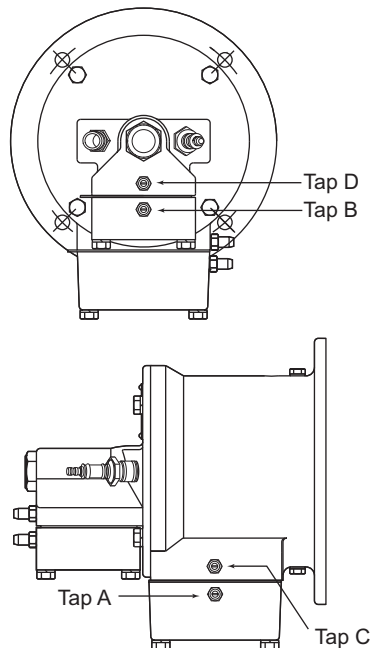

Dimensions and Specifications

Dimensions in mm (inches)

Combustors

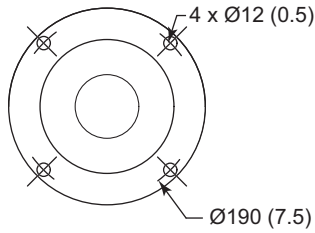
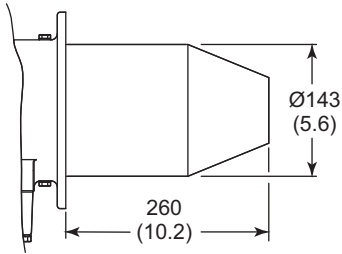

Alloy Combustor (AISI 310)

Weight: 4.2 lbs (1.9 kg)

Maximum Chamber Temp: 1,750°F (940°C)

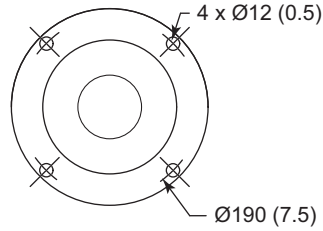
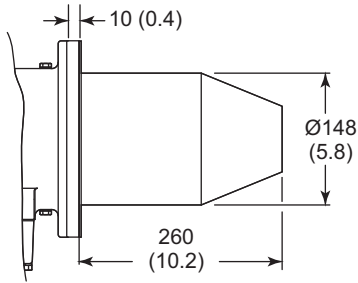

Silicon Carbide Combustor

Weight: 3.1 lbs (1.5 kg)

Maximum Chamber Temp: 2,500°F (1,371°C)

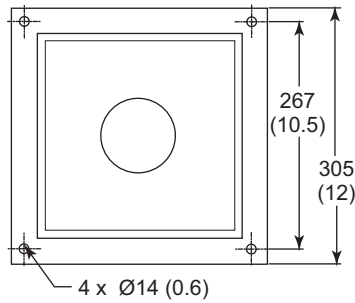
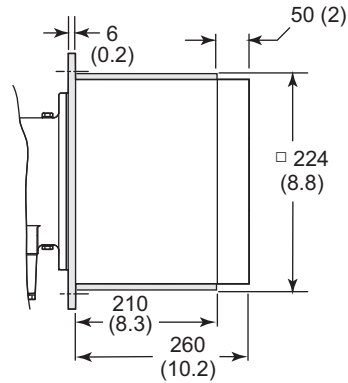

Refractory Combustor with AISI 330 wrapper

Weight: 66 lbs (30 kg)

Maximum Chamber Temp: 2,800°F (1,538°C)

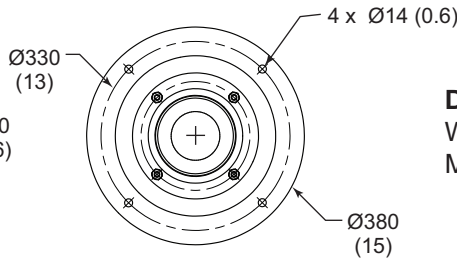
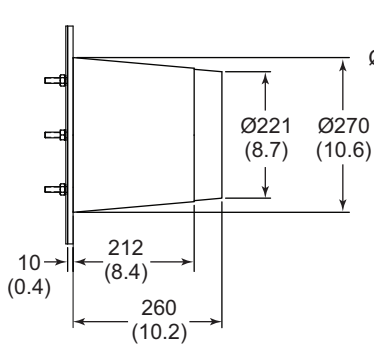

Down-Firing Block with AISI 330 wrapper

Weight: 77 lbs (35 kg)

Max. Chamber Temp: 2,800°F (1,535°C)

Exhaust Outlet Diameter

Medium Velocity: Ø105 (4.1)

High Velocity: Ø85 (3.3)