

Eclipse RatioMatic

Burners

Model RM0100

Version 5

Parameter	Specification		
	Chamber Pressure "w.c. (mbar)	50 Hz	60 Hz
Blower Type			
Maximum Input, BTU/hr (kW)¹ <i>Contact factory for varying chamber pressures or pressures outside the range or varying chamber pressure conditions.</i>	-2.0 (-5,0)	1,375,000 (403)	1,295,000 (379)
	-1.0 (-2,5)	1,295,000 (379)	1,210,000 (354)
	0.0 (0,0)	1,210,000 (354)	1,120,000 (328)
	1.0 (2,5)	1,120,000 (328)	1,020,000 (298)
	2.0 (5,0)	1,020,000 (298)	915,000 (268)
Minimum Input On-Ratio, BTU/hr (kW)	with high turndown ratio regulator	30,000 (9)	
	with standard ratio regulator	40,000 (12)	
Main Gas Inlet Pressure, "w.c. (mbar)² • Fuel pressure at ratio regulator inlet	10 to 20 (25 to 50)		
High Fire Flame Length, inches (mm) • Measured from the outlet end of the combustor	Natural Gas	32 (813)	
	Propane / Butane	38 (965)	
Maximum Chamber Temperature, °F (°C)	Alloy Tube	1500 (815)	
	SiC Tube	1900 (1038)	
Flame Detection	Flamerod or UV Scanner		
Fuel	Natural Gas, Propane, Butane ³ <i>(For any other mixed gas, contact Eclipse Inc.)</i>		
Blower Motor Power, Hp	0.5		
Weight, lbs (kg)⁴	88 (40)		
Approvals	 AN30		

¹ Maximum inputs for packaged blower versions are given for the standard combustion air blower without an inlet air filter.

² For proper performance, this pressure must be kept constant across the burner operating range.

³ See Design Guide 111 for more information about typical fuel composition and properties.

⁴ All weights are approximate.

• All information is based on laboratory testing. Different chamber sizes or conditions will affect the data.

• All inputs based upon gross calorific values and standard conditions; 1 atmosphere, 70°F (21°C).

• Eclipse reserves the right to change the construction and/or configuration of our products at any time without being obliged to adjust earlier supplies accordingly.

Performance Graphs

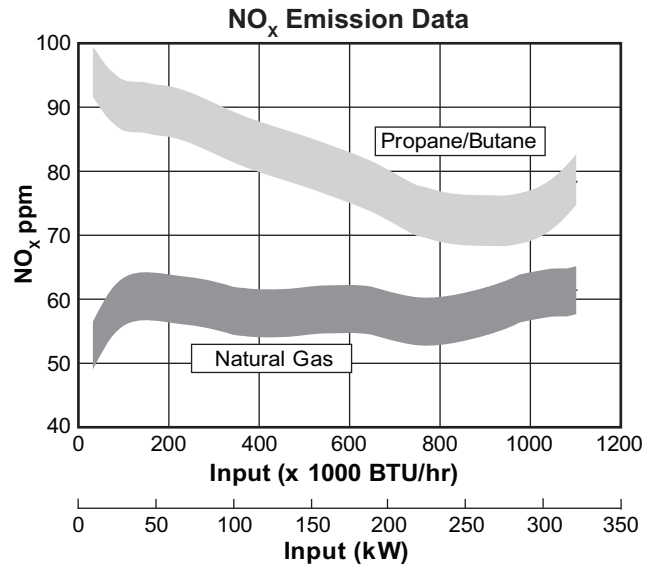
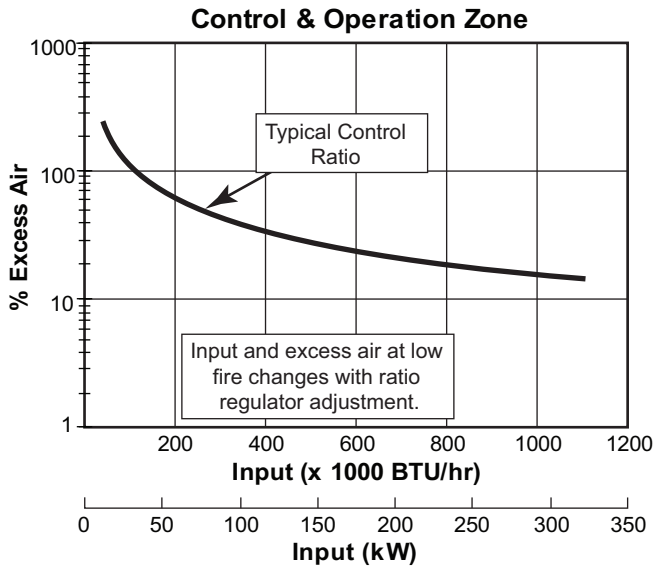

Emission data is given for:

- Ambient combustion air ~70°F (20°C)
- Less than 700°F (370°C) firing chamber
- Minimal process air velocity
- Low fire input adjusted to 40,000 BTU/hr (12 kW)
- ppm volume, dry @ 3% O₂
- Neutral chamber pressure

Emissions are influenced by:

- Chamber conditions
- Fuel type
- Firing rate
- Ratio regulator adjustment
- Combustion air temperature

CO emission is largely influenced by chamber conditions. Contact your local Eclipse Combustion representative for an estimate of CO emission on your application

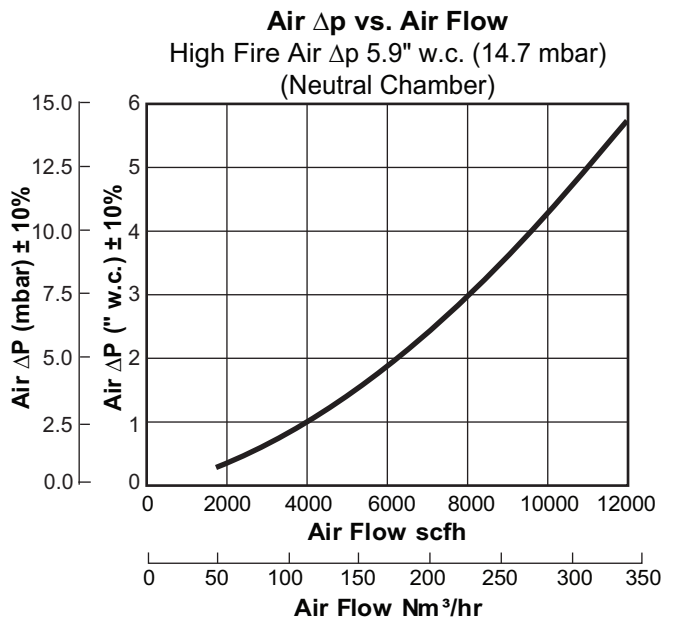
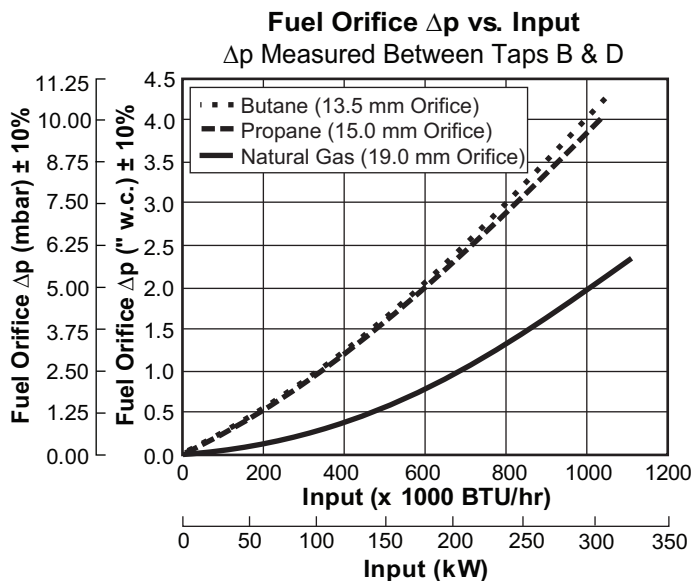

Dimensions and Specifications

Dimensions in mm (in)

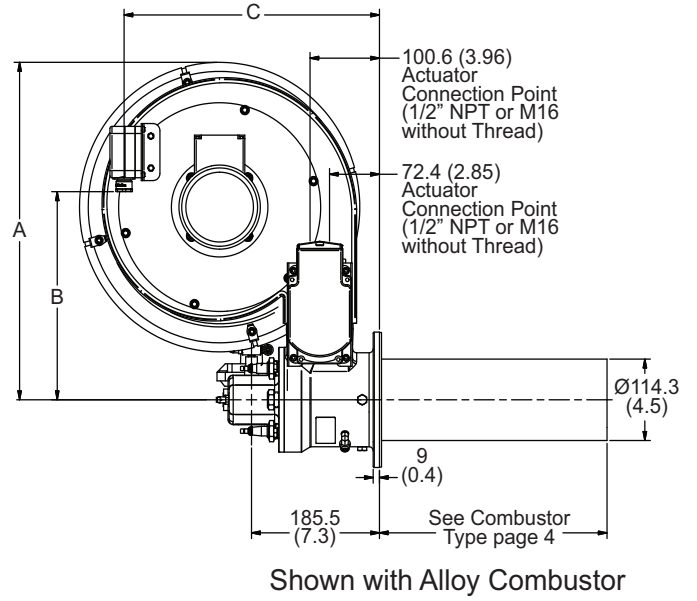
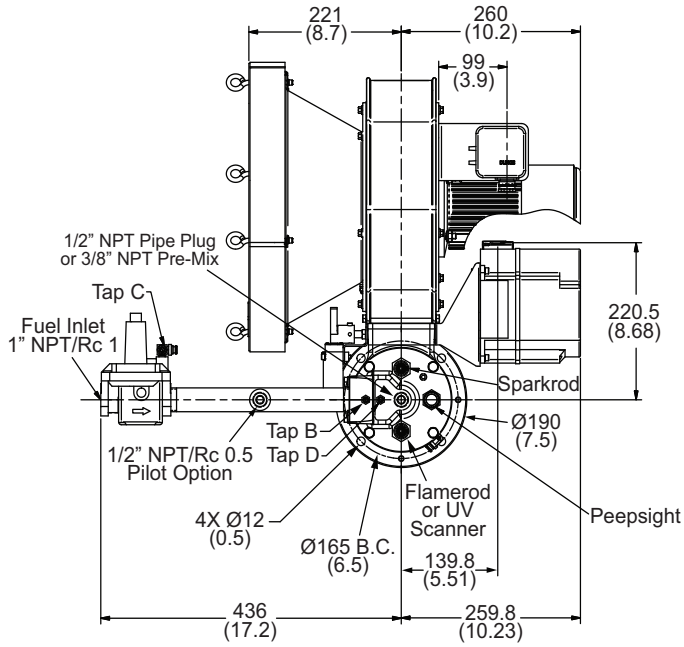

Blower Size	A	B	C
50 Hz	534 (21.0)	384 (15.1)	310 (12.2)
60 Hz	481 (18.9)	342 (13.5)	320 (12.6)

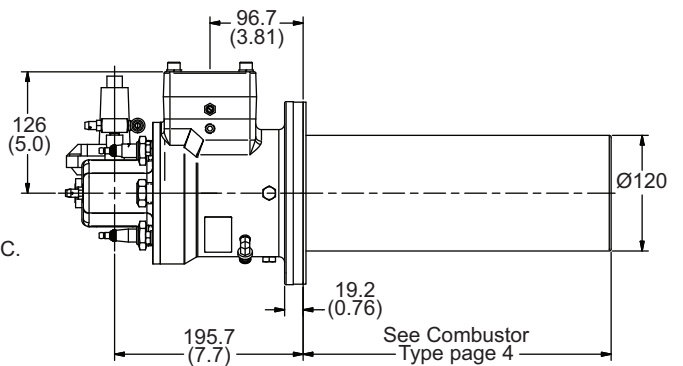
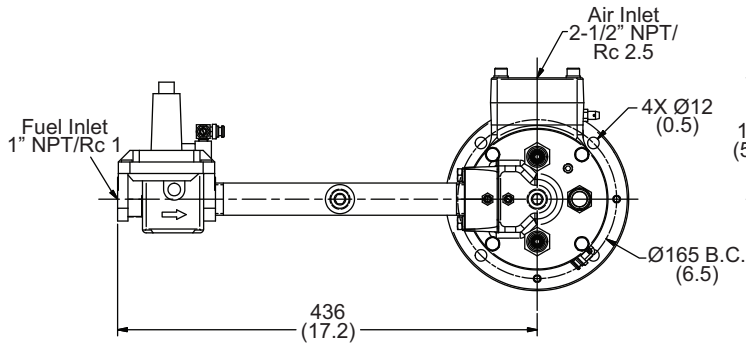

Combustor Types

Alloy Combustor

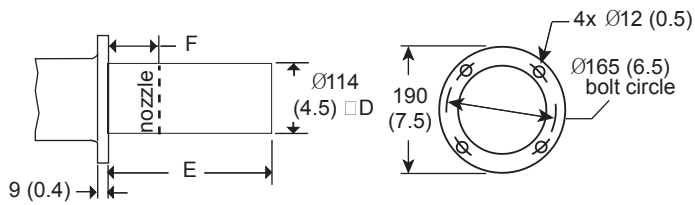

Silicon Carbide Combustor

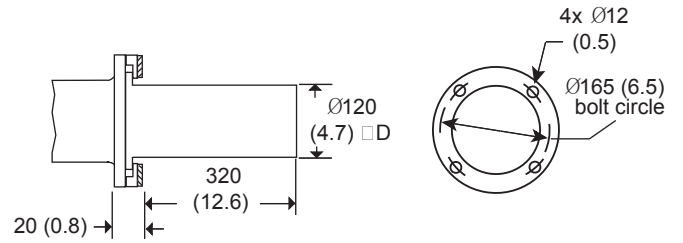

E	F
254 (10.0)	84 (3.3)
330 (13.0)	160 (6.3)
406 (16.0)	236 (9.3)

Burner Configurations

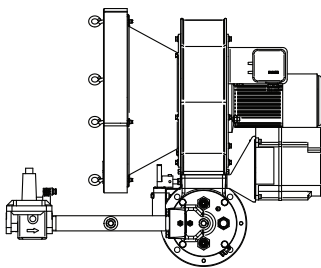

Upright Left Hand Piping

Inverted Left Hand Piping

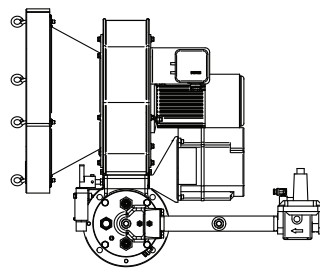
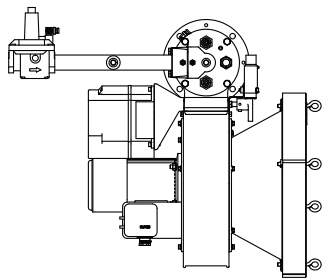

Upright Right Hand Piping

Inverted Right Hand Piping

