



# BK-G4



## Compact diaphragm meters for residential installations

### Applications

- **Media**  
Natural gas, town gas, propane, butane, air, inert gas
- **Industries Gas**  
distribution
- **Tasks**  
Measurement of gas volume

### Measuring principle

The internal, separated measuring unit contains four measuring chambers which are separated by synthetic diaphragms. The chambers are filled and emptied periodically and the movement of the diaphragm is transferred via a gear to the crankshaft. In turn, this shaft moves the valves which control the gas flow. The revolutions of the crank shaft are transferred via a drive gear to the index.

### Brief information

BK-G4 is a compact residential diaphragm gas meter which has been designed to meet the highest demand with regard to accuracy of measurement and safety. It incorporates both innovative features and Elster Kromschroder's gas measurement know-how of many decades.

The meter is supplied as a top-in-top-out, two pipe version. The housing can be made of steel (folded model) or aluminum (screw-connection model).

In the measuring unit, the diaphragms are moving stress free without mechanical stops. This ensures both low bearing loads and a quiet operation. The dimensionally stable synthetic diaphragm has the proven stadium-shaped form.

High-grade materials and components as well as the patented slide control (K-system) ensures a high quality standard. The K-system synchronizes the operation of the slides with the current flow through the measuring chamber thus achieving minimum flow channels and an extremely high accuracy of measurement.

Due to the small slides, BK-G4 is not susceptible to contamination. The measuring unit is adjusted by a patented needle and scale system.

Although the design is very robust, the meters are still measuring instrument and as such should be handled with care.

### Main features

- Meets the requirement of OIML R6 and R31
- NOM 014 and EC approved
- Flow rates from 0.04 to 6 m<sup>3</sup>/h
- Maximum operating pressure 0.5, 1,1.5 bar (depend on body material)
- Water tight index
- Pulse magnet for 0.1 unit/pulse incorporated for remote reading purpose
- Low noise level
- Low susceptibility to contamination
- Operating gas temperature from -20 °C to +50 °C
- Stable synthetic, stadium-shaped diaphragm
- Anti-reverse operation
- Enlarge index numerals
- Cyclic Volume 1.2 Liters

### Optional features

- Anti-reverse flow valve
- Retro-fit low frequency pulser



บริษัท เอดีดี เฟอร์เนส จำกัด

**ADD FURNACE CO.,LTD.**

44 ซอยบรมราชชนนี 70 ถนนบรมราชชนนี แขวงศาลาธรรมสพน์ เขตทวีวัฒนา กรุงเทพฯ 10170

โทร: 02-888-3472 โทร. ออกรับ:(:08-08-170-170 แฟกซ์: 02-888-3258

https://www.add-furnace.com E-mail: [sales@add-furnace.com](mailto:sales@add-furnace.com)

## BK-G4

Compact gas meter for residential installations

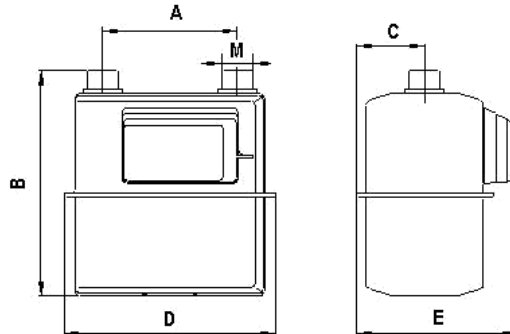

### Dimensions

Meter Configuration	Dimension (mm)						Body Material	Weight (kg)
	A	B	C	D	E	M		
Top-in Top-out	110	221	67	193	157	M30x2	Steel	1.9
	130			205		M34x1.5		
	130	215	72	202	165	M34x1.5 G1"	Aluminum	2.15

### Typical error curve

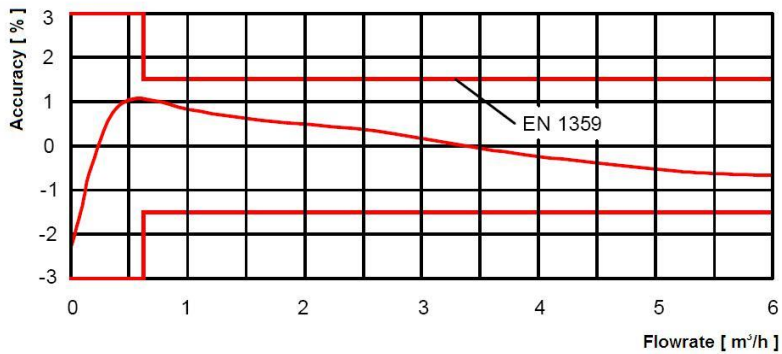

### Order information

#### Diaphragm Meter G4

Configuration Type

Connection Size

Flow Direction

### Pressure loss curve

