



บริษัท เอดีดี เฟอร์เนส จำกัด

ADD FURNACE CO.,LTD.

44 ซอยบรมราชชนนี 70 ถนนบรมราชชนนี แขวงศาลาธรรมสพน์ เขตทวีวัฒนา กรุงเทพฯ 10170

โทร: 02-888-3472 โทร: ออกแบบ:08-08-170-170 แฟกซ์: 02-888-3258

https://www.add-furnace.com E-mail: [sales@add-furnace.com](mailto:sales@add-furnace.com)



SC-107  
APRIL 28, 2011

Fireeye®

FLAME SCANNERS

UV Non Self-Checking Scanner Models:

UV7A4, UV7R4

UV Self-Check Scanner Model:

UV7SC

UV7SC



UV7A4



UV7R4



## DESCRIPTION

The non self-check UV7A4, UV7R4 and self-check UV7SC scanners are used with the MBSERIES Multi-Burner control, the SBSERIES single burner control and the flame sensing modules, MBPF-100S and MB-600PF.

The UV7A4 scanner features high sensitivity ultraviolet (UV) for monitoring gas or oil flames which cycle on and off frequently. The Fireeye flame safeguard checks for a short-circuited, or "run- away" scanner at the beginning and end of each flame cycle. The scanner is UL listed, CSA certified and FM approved. It comes with a 122 cm (4 ft.) shielded flexible cable and a 1/2" F.N.P.T. insulated nylon coupling and is ideal for high temperature applications.

The UV7R4 Scanner is a 90° right angle ultraviolet flame scanner. This sensor features high sensitivity ultraviolet (UV) for monitoring gas or oil flames which cycle on and off frequently. The Fireeye flame safeguard checks for a short-circuited, or "runaway" scanner at the beginning and end of each flame cycle. The scanner is UL listed, CSA certified and FM approved. It comes with 72 inch (1830mm) unshielded lead wires and is safeguarded against reverse connection.

The self-check UV7SC scanner is used for continuous gas or oil flames. A mechanical shutter in the scanner closes every ten seconds, at which time the scanner's internal circuit checks for a flame signal. If a signal is present, indicating a runaway scanner, the output signal is permanently interrupted, shutting down the flame safeguard system. The scanner features a high quality fused silica quartz lens, machined alloy housing with seals and a long life push-pull electro-magnetically driven photo shutter. The detectors and signal processor automatically check every 10 seconds. It can be replaced without disturbing wiring. The UV7SC requires cable assembly, P/N 59-504-010.

The UV tube is made of quartz and is filled with a gas that ionizes when struck by UV radiation from the flame. In the absence of UV radiation, the gas acts as an insulator between two electrodes which are mounted inside the tube. These electrodes are energized continuously by a high voltage. During combustion, UV radiation ionizes the gas, causing current pulses to flow between the electrodes. These current pulses result in a flame signal which is transmitted to the amplifier in the control, where it is processed to energize or hold in the flame relay.



บริษัท เอดีดี เฟอร์เนส จำกัด

**ADD FURNACE CO.,LTD.**

44 ซอยบรมราชชนนี 70 ถนนบรมราชชนนี แขวงศาลาธรรมสพน์ เขตทวีวัฒนา กรุงเทพฯ 10170

โทร: 02-888-3472 โทร: ออกแบบ:08-08-170-170 แฟกซ์: 02-888-3258

<https://www.add-furnace.com> E-mail: [sales@add-furnace.com](mailto:sales@add-furnace.com)



**WARNING: When installing or replacing UV scanners, a minimum pilot turndown test on pilot ignited burners and a spark pickup test on all burners must be performed.**

## APPLICATION

UV scanners are recommended for detecting flames from standard fuel gases, some waste gases and light oil fuels such as No. 2 oil. Flames from heavier oils can be detected with UV scanners but the unburned fuel shroud and/or atomization shroud can block passage of the UV from the flame zone to the UV tube, causing nuisance burner/boiler trips. Infrared detection is recommended for fuel oil heavier than No. 2, and some installations where waste gases are burned together with natural gas as a main flame.

*NOTE: Certain safety codes and regulations require the use of self-checking ultraviolet scanners.*

## SPECIFICATIONS

### UV7A4

<b>Supply</b>	425 VDC $\pm$ 25 VDC
<b>Discharge Current</b>	0.3 mA
<b>Supply Wiring</b>	122 cm (4 ft.) shielded instrument cable with two #18 AWG conductors
<b>Max Operating Distance</b>	76m (250 ft.)
<i>(Total Wire Length)</i>	
<b>Temperature Range</b>	-20 °to +125 °C (-4 °to 257 °F)
<b>Shipping Weight</b>	1.4 kilograms (3 lbs.)
<b>Options</b>	Magnifying lens (P/N 46-185)

### UV7R4

<b>Supply Voltage</b>	425 VDC $\pm$ 25 VDC
<b>Discharge Current</b>	0.1 mA
<b>Supply Wiring</b>	183 cm (6 ft.) cable lead of two #18 AWG conductors
<b>Max Operating Distance</b>	76m (250 ft.)
<i>(Total Wire Length)</i>	
<b>Temperature Range</b>	-20 °to +60 °C (-4 °to 140 °F)
<b>Shipping Weight</b>	1.4 kilograms (3 lbs.)
<b>Options</b>	Magnifying lens (P/N 46-185), 1/2" F.N.P.T. insulated coupling (P/N 35-319) or radiation shield (P/N 36-936)



บริษัท เอดีดี เฟอร์เนส จำกัด

**ADD FURNACE CO.,LTD.**

44 ซอยบรมราชชนนี 70 ถนนบรมราชชนนี แขวงศาลาธรรมสพน์ เขตทวีวัฒนา กรุงเทพฯ 10170

โทร: 02-888-3472 โทร: ออกแบบ:08-08-170-170 แฟกซ์: 02-888-3258

<https://www.add-furnace.com> E-mail: [sales@add-furnace.com](mailto:sales@add-furnace.com)

## UV7SC

<b>Electrical:</b>	Supply Voltage: 120V +10/-15%, 60HZ Supply Current: 0.04A
<b>Mechanical:</b>	Output: 10V square wave frequency modulated Overall Length: 197 mm (7-3/4") Diameter: 83 mm (3-1/4") Housing Material: Machined 6061 aluminum alloy
<b>Finish:</b>	Clear anodized Sight Tube Entrance: 25 mm (1") pipe thread Purge Air Entrance: 10 mm (3/8") pipe thread Purge Air Flow: 5 cfm, 10 psi maximum
<b>Installation Requirements:</b>	Cable and connector for scanner (P/N 59-504-010)
<b>Supply Wiring</b>	Instrumentation cable with two pairs of individually shielded #18 AWG conductors, 60 °C (140 °F), 300V minimum, ALPHA #5620B1802 or BELDEN #9368
<b>Temperature Range</b>	-20 ° to +60 °C (-4 ° to 140 °F) case temperature
<b>Shipping Weight</b>	2 kilograms (4.5 lbs.)
<b>Optical</b>	Angle of View: @ 2.5 ° depending on sight pipe size and length Spectral Sensitivity: 180 to 230 nanometers; scanner is solar blind

### IMPORTANT NOTE

*The information provided in this bulletin is directed to assist boiler and combustion service technicians who are experienced in the installation and operation of Fireye Flame Safety equipment. Persons not familiar with Fireye products should contact the nearest Fireye representative or other qualified service group.*

*The UV7A4, UV7R4, and UV7SC as well as all other Fireye scanners, are designed to be used exclusively with the appropriate Fireye Flame safeguard and Burner Management controls. The application of these scanners to equipment other than Fireye should be reviewed for approval by Fireye.*

---

## INSTALLATION OF UV SCANNERS



**WARNING: THE LEADS FROM THE UV7R4 SCANNER TO THE CONTROL MUST BE SHIELDED TO PREVENT ELECTRICAL NOISE FROM GENERATING A FALSE FLAME SIGNAL TO THE CONTROL.**

Where possible, obtain the Burner Manufacturer's Instructions for mounting the scanner. This information is available for most standard burners. The scanner mounting should comply with the following General Instructions:



1. The quartz UV tube is brittle. Care must be exercised to avoid dropping or otherwise striking the scanner with force. Keep the scanner protected until mounted.
2. Position the UV scanner within 36 inches of the flame to be monitored.
3. Select a scanner location that will remain within the ambient temperature limits of the UV Scanner (200 °F). If cooling is required, use an insulating coupling (Fireye P/N 35-319).
4. The UV Scanners are designed to seal off against pressures up to 1 PSI. To seal against higher pressures, install a union coupling with quartz window (P/N 60-1257). Add cooling air to reduce the scanner sight pipe temperature.
5. Install the scanner on a standard 1/2 in. NPS (1 in. NPT for UV7SC) pipe whose position is rigidly fixed. If the scanner mounting pipe sights through the refractory, do not extend it more than halfway through. Swivel flanges are available if desired (P/N 60-302). The sight pipe must permit an unobstructed view of the pilot and/or main flame, and both pilot and main flames must completely cover the scanner field of view. Oil and gas flames radiate more ultraviolet energy from the base of the flame than from further out in the flame. This fact should be considered when installing the scanner sight pipe

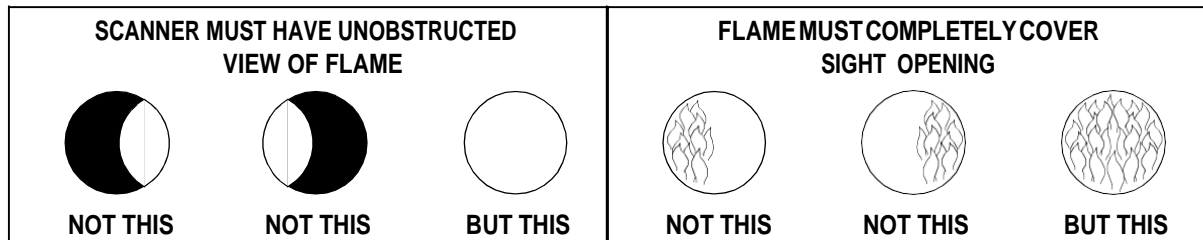

6. Since the radiated energy from an electric spark ignitor is very rich in the UV region, the field of view should be aimed so that it does not see an electric spark ignitor nor any reflector that is close to the spark.



**CAUTION: The unprotected leads must be run in electrical conduit in order to eliminate pickup of electrical noise which could present an unsafe condition.**

To prevent spark pickup by the UV detector, close and/or disconnect all pilot and main fuel valves. Operate the control through a burner startup cycle to determine that ignition spark cannot be detected. Burner will not ignite if spark is detected.

7. Avoid running the scanner cables or conduit in close proximity to hot surfaces at the burner.
8. Avoid running the scanner conduit in close proximity to high energy ignition wires.
9. Smoke or unburned combustion gases absorb ultraviolet radiation. On installations having negative pressure combustion chamber, a small hole drilled in the scanner sight pipe will assist in keeping the pipe clean and free of smoke. For positive pressure furnaces, provide clean air to pressurize the sight pipe, if necessary.
10. Two UV Scanners may be installed on one burner if it is necessary to view two areas to obtain reliable detection of the flame. They should be wired in parallel.
11. To increase scanner sensitivity with the UV Scanners, a quartz lens permits location of the scanner at twice the normal distance. (Union w/quartz lens P/N 60-1290).
12. Request the assistance of any Fireye Field Office for recommendations of a proper scanner installation on a non-standard application.



**CAUTION: Ultraviolet tubes can simulate flame when exposed to high levels of "X" and GAMMA radiation. The table below indicates the maximum dose of radiation that a UV tube can be exposed.**



SOURCE	MAXIMUM DOSE	
Cobalt 60 (CO <sub>60</sub> )	7.5mR/Hr	
Iridium (IR <sub>192</sub> )	1.0mR/Hr	
X-Ray	4mR/Hr	150kV @ 0.2mA
X-Ray	1mR/Hr	150kV @ 0.4mA

### Minimum Pilot Test

This test assures that the flame detector will not detect a pilot flame too small to reliably light off the main flame. The test should be made on every new installation and following any repositioning of the flame detector. **THE MINIMUM PILOT TESTS MUST BE ACCOMPLISHED BY A TRAINED AND QUALIFIED BURNER TECHNICIAN.**

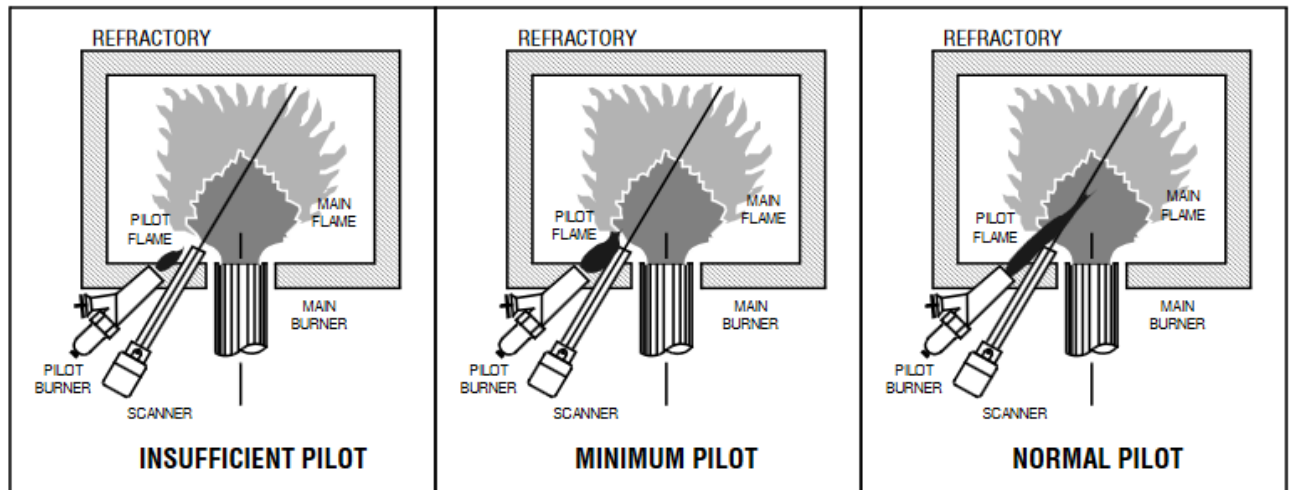

**SPARK REJECTION TEST. CAUTION:** The scanner must not sight the ignition spark directly or any part of the burner that can reflect the spark back to the scanner. the scanner must not see a pilot flame that is too small to reliably ignite the main flame. Test procedures vary according to the control used. See procedures as described in the technical bulletin for the control being installed.

## WIRING – UV SCANNERS



**Incorrect sensor installation may cause the sensor to generate a false flame signal. This can cause unburned fuel to collect in the combustion chamber, resulting in explosions, injuries, and property damage. Be certain that the flame sensor detects only the pilot and main flames, not glowing refractory or burner parts.**

1. Route sensor wiring a sufficient distance from ignition and other high voltage wiring to avoid electrical interference.
2. If sensor wiring is to extend beyond the factory-supplied cable length, use #14 to #18 AWG wire suitable for 75 °C (167 °F) and 600 volt insulation, and run each pair of leads in its own conduit or shielded cable. Multiple shielded cables can be run in a common conduit, but only on short distances.



3. Depending on field conditions, sensor wiring can be up to 76.25 m (250 ft.) for UV scanners. For extended scanner wiring up to 500 feet, or for shorter lengths to reduce signal loss, use a shielded wire (Belden 8254, RG-62/U coaxial cable, or equal) for each scanner wire. The ends of the shielding must be taped and not grounded.
4. Asbestos insulated wire should be avoided.
5. Multi conductor cable is not recommended.
6. High voltage ignition wiring should not be installed in the same conduit with flame detector wires.

---

## MAINTENANCE

### Ultraviolet Scanners

The viewing area of the scanner must be kept clean. Even a small amount of contamination on the lens will reduce the flame signal reaching the detector by a measurable amount. Wipe the viewing area routinely using a soft cloth dampened with concentrated detergent, then wipe dry.

### Flame Signal Strength

Routine observation of the flame signal strength will forewarn any deterioration in the capability of the flame detector or its application.

### Periodic Safety Check

It is recommended that a procedure be established to test the complete flame safeguard system at least once a month,. This test should verify the proper operation of all limit switches and safety inter- locks as well as flame failure protection and fuel safety shutoff valve tightness.

### Rotation

It is recommended that control and scanner units purchased as spares be installed periodically to ensure proper operation.

---

## ACCESSORIES

PART NUMBER	DESCRIPTION
35-319	HEAT INSULATOR 1/2 IN NPT THREADS EACH END (MALE AND FEMALE)
60-1257	1/2 IN NPT UNION WITH QUARTZ WINDOW
60-1290	1/2 IN NPT UNION WITH QUARTZ LENS TO INCREASE SENSITIVITY
60-1199-1	1 IN NPT SEALING COUPLINGWITH QUARTZ WINDOW
60-1199-2	1 IN BSP SEALING COUPLINGWITH QUARTZ WINDOW
60-1664-3	1 IN NPT SWIVEL MOUNT
60-302	1/2/IN SWIVEL MOUNT
46-185	MAGNIFYING LENS ASSEMBLY
46-186	MAGNIFYING LENS
36-936	SCANNER SUPPORT (MAX TEMP @ 475 F)
59-504-010	CABLE AND CONNECTOR, 10 FEET FOR UV7SC



บริษัท เอดีดี เฟอร์เนส จำกัด

ADD FURNACE CO.,LTD.

44 ซอยบรมราชชนนี 70 ถนนบรมราชชนนี แขวงศาลาธรรมสพน์ เขตทวีวัฒนา กรุงเทพฯ 10170

โทร: 02-888-3472 โทร: ออกแบบ:08-08-170-170 แฟกซ์: 02-888-3258

https://www.add-furnace.com E-mail: [sales@add-furnace.com](mailto:sales@add-furnace.com)

## DIMENSIONS

### UV7A4

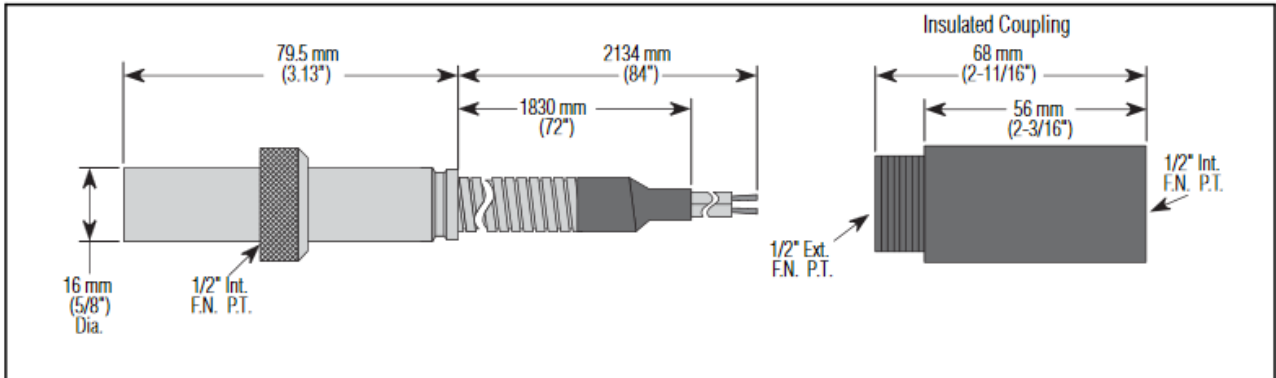

### UV7R4

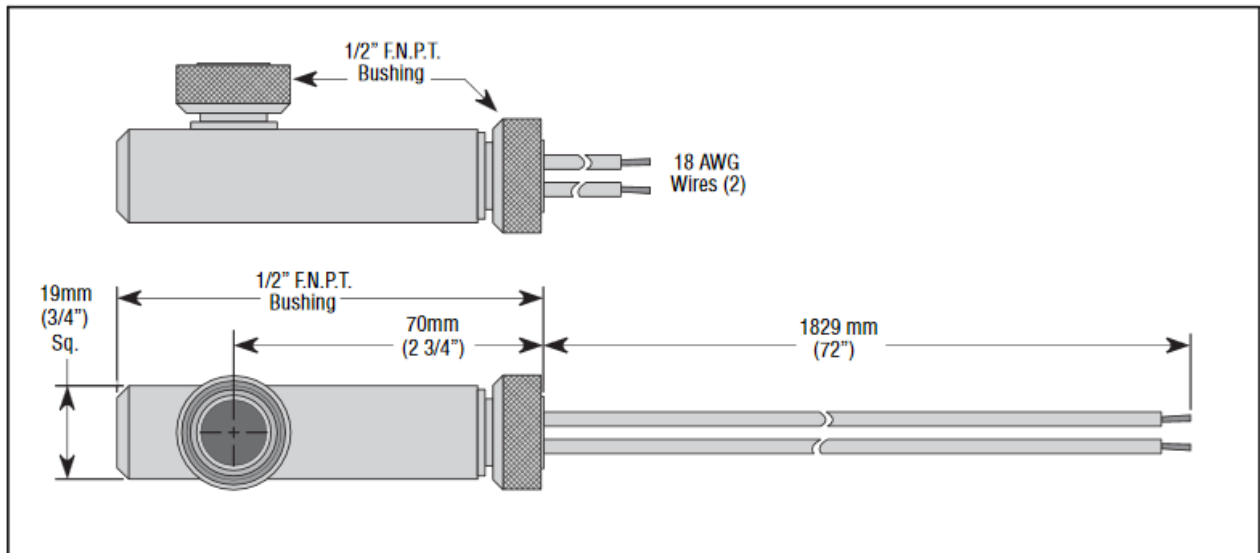

### UV7SC

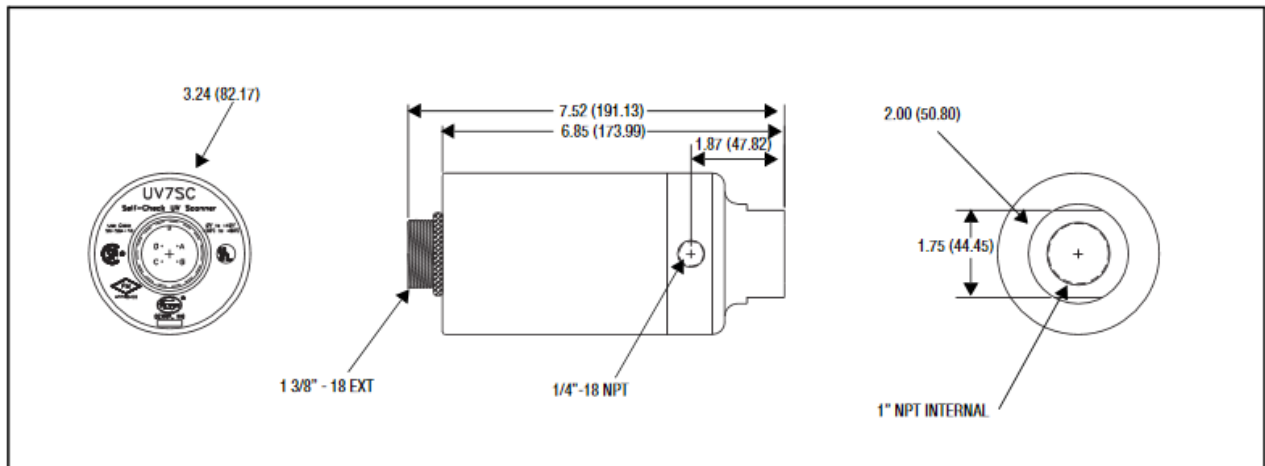



บริษัท เอดีดี เฟอร์เนส จำกัด

ADD FURNACE CO.,LTD.

44 ซอยบรมราชชนนี 70 ถนนบรมราชชนนี แขวงศาลาธรรมสพน์ เขตทวีวัฒนา กรุงเทพฯ 10170

โทร: 02-888-3472 โทร: ออกแบบ:08-08-170-170 แฟกซ์: 02-888-3258

<https://www.add-furnace.com> E-mail: [sales@add-furnace.com](mailto:sales@add-furnace.com)



---

## NOTICE

When Fireye products are combined with equipment manufactured by others and/or integrated into systems designed or manufactured by others, the Fireye warranty, as stated in its General Terms and Conditions of Sale, pertains only to the Fireye products and not to any other equipment or to the combined system or its overall performance.

---

## WARRANTIES

FIREYE guarantees for *one year from the date of installation or 18 months from date of manufacture* of its products to replace, or, at its option, to repair any product or part thereof (except lamps, electronic tubes and photocells) which is found defective in material or workmanship or which otherwise fails to conform to the description of the product on the face of its sales order. **THE FOREGOING IS IN LIEU OF ALL OTHER WARRANTIES AND FIREYE MAKES NO WARRANTY OF MERCHANTABILITY OR ANY OTHER WARRANTY, EXPRESS OR IMPLIED.** Except as

specifically stated in these general terms and conditions of sale, remedies with respect to any product or part number manufactured or sold by Fireye shall be limited exclusively to the right to replacement or repair as above provided. In no event shall Fireye be liable for consequential or special damages of any nature that may arise in connection with such product or part.



FIREYE®  
3 Manchester Road  
Derry, New Hampshire 03038 USA  
[www.Fireye.com](http://www.Fireye.com)

SC-107  
APIRIL 28, 2011  
Supersedes February 14, 2011