

1301 Series High-Pressure Regulators

! WARNING

Failure to follow these instructions or to properly install and maintain this equipment could result in an explosion, fire and/or chemical contamination causing property damage and personal injury or death.

Fisher® regulators must be installed, operated and maintained in accordance with federal, state and local codes, rules and regulations and Fisher instructions.

If the regulator vents gas or a leak develops in the system, service to the unit may be required. Failure to correct trouble could result in a hazardous condition.

Installation, operation and maintenance procedures performed by unqualified personnel may result in improper adjustment and unsafe operation. Either condition may result in equipment damage or personal injury. Use qualified personnel when installing, operating and maintaining the 1301 Series high-pressure regulator.



P1025

Figure 1. Type 1301F High-Pressure Regulator

Introduction

Scope of the Manual

This Instruction Manual provides instructions for the installation, adjustment, maintenance and parts ordering of the Types 1301F and 1301G high-pressure regulators.

Product Description

Types 1301F and 1301G regulators are direct-operated, high-pressure regulators, which can be used where high-pressure gas must be reduced for use as pilot supply pressure in pilot-operated regulators or as loading pressure in pressure-loaded regulators.

Types 1301F and 1301G regulators can also be used in many other applications due to their rugged design as high-pressure reducing regulators for various fluids such as air, gas, water and other liquids.

The Type 1301F can handle outlet pressures from 10 to 225 psig / 0.69 to 15.5 bar in three ranges and the Type 1301G can handle outlet pressures from 200 to 500 psig / 13.8 to 34.5 bar in one range.



Specifications

Specifications section lists the specifications for Types 1301F and 1301G high-pressure regulators. The maximum outlet pressure for a given regulator as it comes from the factory is stamped on the regulator nameplate.

Available Configurations

Type 1301F: Direct-operated, high-pressure reducing regulator for inlet pressures to 6000 psig / 414 bar and outlet pressure ranges from 10 to 225 psig / 0.69 to 15.5 bar in three ranges

Type 1301G: Direct-operated, high-pressure reducing regulator for inlet pressures to 6000 psig / 414 bar and an outlet pressure range of 200 to 500 psig / 13.8 to 34.5 bar

Body Size and End Connection Style

1/4 NPT (one inlet and two or three outlet connections), CL300 RF, CL600 RF and CL1500 RF; or PN 25 RF (all flanges are 125 RMS)

Maximum Allowable Inlet Pressure⁽¹⁾

Brass Body:

Air and Gas:

6000 psig / 414 bar at or below 200°F / 93°C
and 1000 psig / 69.0 bar above 200°F / 93°C

Liquid:

Polytetrafluoroethylene (PTFE) Disk:
1000 psig / 69.0 bar

Nylon (PA) Disk:

Water: 1000 psig / 69.0 bar
Other Liquids: 2000 psig / 138 bar

Stainless Body:

Air and Gas: 6000 psig / 414 bar

Liquid:

Polytetrafluoroethylene (PTFE) Disk:
1000 psig / 69.0 bar

Nylon (PA) Disk:

Water: 1000 psig / 69.0 bar
Other Liquids: 2000 psig / 138 bar

Outlet Pressure Ranges

See Table 1

Maximum Emergency Outlet Pressure⁽¹⁾

Type 1301F: 250 psig / 17.2 bar

Type 1301G: 550 psig / 37.9 bar

Wide-Open Flow Coefficients for Relief Valve Sizing

C_g : 5.0

C_v : 0.13

C_i : 38.5

IEC Sizing Coefficients

X_T : 0.938

F_D : 0.50

F_L : 0.85

Recovery Coefficient

K_m : 0.72

Material Temperature Capabilities⁽¹⁾

Nylon (PA) Valve Disk and

Neoprene (CR) Gaskets:

-20 to 180°F / -29 to 82°C

PTFE Valve Disk and Fluorocarbon (FKM)

Gaskets: -20 to 400°F / -29 to 204°C⁽²⁾

PTFE Valve Disk and Ethylenepropylene (EPDM)

Gaskets: -40 to 300°F / -40 to 149°C

Low Temperature Service

Service to -65°F / -54°C is available with low temperature bolting and special low temperature Nitrile (NBR) O-rings to replace the gaskets.

Service to -80°F / -62°C is available with low temperature bolting and special low temperature Fluorosilicone (FVQM) O-rings to replace the gaskets.

Pressure Registration

Internal

Orifice Size

5/64 in. / 2.0 mm

Spring Case Vents

Type 1301F Brass Spring Case:

Four 5/32 in. / 4.0 mm holes

Type 1301F Stainless Steel Spring Case:

One 1/4 NPT connection

Type 1301G Spring Case:

One 1/8 NPT connection with screen

Approximate Weight

8 pounds / 4 kg

1. The pressure/temperature limits in this Instruction Manual and any applicable standard or code limitation should not be exceeded.

2. Fluorocarbon (FKM) is limited to 180°F / 82°C hot water.

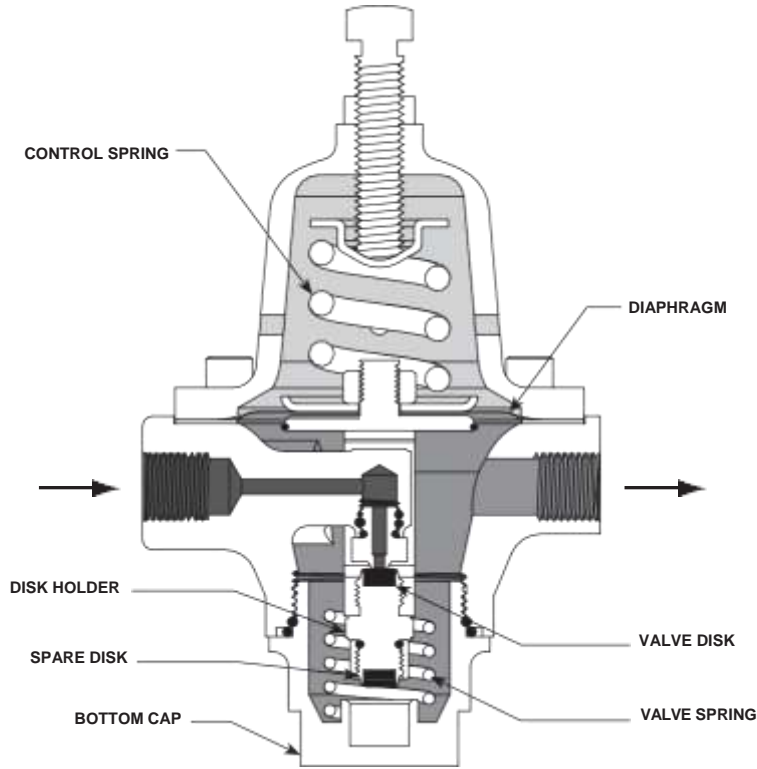

M1015

INLET PRESSURE
 OUTLET PRESSURE
 ATMOSPHERIC PRESSURE

Figure 2. Type 1301F Operational Schematic

Table 1. Outlet Pressure Ranges

TYPE	OUTLET PRESSURE RANGES ⁽¹⁾		SPRING COLOR	SPRING PART NUMBER	SPRING WIRE DIAMETER		SPRING FREE LENGTH	
	psig	bar			In.	mm	In.	mm
1301F	10 to 75	0.69 to 5.2	Blue	1D387227022	0.200	5.08	1.69	42.9
	50 to 150	3.4 to 10.3	Silver	1B788527022	0.225	5.72		
	100 to 225	6.9 to 15.5	Red	1D465127142	0.243	6.17		
1301G	200 to 500	13.8 to 34.5	Silver	1K156027142	0.331	8.41	0.88	22.4

1. All springs can be backed off to 0 psig / 0 bar.

Principle of Operation

The 1301 Series regulators are direct-operated. Downstream pressure is registered internally through the body to the underside of the diaphragm. When downstream pressure is at or above set pressure, the disk is held against the orifice and there is no flow through the regulator. When demand increases, downstream pressure decreases slightly allowing the

regulator spring to extend, moving the yoke and disk assembly down and away from the orifice. This allows flow through the body to the downstream system. As the downstream pressure reaches its setpoint, it starts to overcome the spring force, which is sensed by the diaphragm, moving the yoke and disk assembly up near its orifice, restricting flow across the regulator.

Installation

! WARNING

Overpressuring a regulator or associated equipment may cause leakage, part damage or personal injury due to bursting of pressure containing parts or explosion of accumulated gas. Do not install a regulator where service conditions can exceed the specifications listed on the Specifications section, or any applicable local, state or federal codes and regulations.

Use qualified personnel when installing, operating and maintaining these regulators. Make sure that there is no damage or foreign material in the regulator and that all tubing and piping are clean and unobstructed. The regulator may be installed in any position. Apply pipe compound to the pipeline threads. Connect inlet piping or tubing to the 1/4 NPT connection marked "In" and outlet piping or tubing to one of the 1/4 NPT connections marked "Out". Install a pressure gauge or pipe plug in the unused outlet connections.

If continuous operation of the system is required during inspection or maintenance, install a three-valve bypass around the regulator.

! WARNING

A regulator may vent some gas to the atmosphere. In hazardous gas service, vented gas may accumulate, causing personal injury or equipment damage due to fire or explosion. Vent a regulator in hazardous gas service to a remote, safe location.

The optional stainless steel spring case of the Type 1301F regulator has one 1/4 NPT internal connection. The Type 1301G regulator spring case has one 1/8 NPT internal connection with a screen. To remotely vent the spring case, remove the screen, if present, and connect 1/4 or 1/8 NPT piping or tubing to the spring case connection. The piping or tubing should vent the spring case to a safe location, have as few bends as possible, and have a screened vent on its exhaust end.

Each regulator is factory-set for the pressure setting specified on the order. If no setting is specified, outlet pressure is factory-set at the midpoint of the regulator spring range. If pressure adjustment is necessary, refer

to the Startup section. In all cases, check the spring setting to make sure it is correct for the application.

Overpressure Protection

The 1301 Series regulators have an outlet pressure rating lower than their inlet pressure rating. If actual inlet pressure can exceed the outlet pressure rating, outlet overpressure protection is necessary. However, overpressuring any portion of the regulators beyond the limits in Specifications section may cause leakage, damage to regulator parts or personal injury due to bursting of pressure-containing parts.

Some type of external overpressure protection should be provided if inlet pressure will be high enough to damage downstream equipment. Common methods of external overpressure protection include relief valves, monitoring regulators, shutoff devices and series regulation.

If the regulator is exposed to an overpressure condition, it should be inspected for any damage that may have occurred. Regulator operation below these limits does not preclude the possibility of damage from external sources or from debris in the pipeline.

Startup

With installation completed and downstream equipment adjusted, slowly open the upstream and downstream block valves while using pressure gauges to monitor pressure.

If adjustment is necessary, loosen the locknut (key 18, Figures 3 and 4), and turn the adjusting screw (key 15, Figures 3 and 4) clockwise to increase the set pressure or counterclockwise to decrease the set pressure. Monitor pressure with gauges during adjustment. When adjustment is complete, tighten the locknut. If the desired outlet pressure is not within the range of the regulator spring, install a spring with a desired range according to the Maintenance section.

Shutdown

First, close the upstream shutoff valve, and then, close the downstream shutoff valve. Next, open the vent valve between the regulator and the downstream shutoff valve and open the vent valve between the regulator and the upstream shutoff valve. If vent valves are not installed, safely bleed off both inlet and outlet pressures and check that the regulator contains no pressure.

Maintenance

Regulator parts are subject to normal wear and must be inspected and replaced as necessary. The frequency of inspection and parts replacement depends on the severity of service conditions and the requirements of local, state and federal rules and regulations.

Instructions are given below for disassembly and assembly of parts.

! WARNING

To avoid personal injury or equipment damage from sudden release of pressure or explosion of accumulated gas, do not attempt any maintenance or disassembly without first isolating the regulator from system pressure and relieving all internal pressure from the regulator.

Disassembly

The following procedure describes how to completely disassemble the regulator. When part replacement or inspection is required, complete only those steps necessary to accomplish the job. Key numbers referenced are shown in Figure 3 for the Type 1301F regulator and in Figure 4 for the Type 1301G regulator unless otherwise indicated.

1. Loosen the locknut (key 18).
2. Turn the adjusting screw (key 15) counterclockwise to remove spring compression.
3. Remove the bottom cap (key 3), bottom cap O-ring (key 14) and spring (key 10).
4. Unthread the valve disk assembly (key 6) from the yoke (key 4).
5. Remove the valve disk collar (key 22) from the valve disk assembly.
6. Remove the spring case cap screws (key 16), and separate the spring case (key 2) from the body (key 1).
7. Remove the upper spring seat and spring (keys 9 and 11).
8. Refer to Figure 5. Unscrew the diaphragm locknut (key 19), and remove the diaphragm plate (key 8), the two diaphragms (key 7) and the diaphragm plate gasket (key 13).
9. Remove the screws (key 17) from the yoke, and take the lower and upper halves of the yoke out of the body. The yoke halves are a matched set and need to be kept together.

10. Unscrew the orifice (key 5). Examine seating edge of orifice. Replace with a new part if worn or nicked.

Assembly

This procedure assumes that the regulator was completely disassembled. If not, start these instructions at the appropriate step. Key numbers used are shown in Figure 3 for the Type 1301F regulator and in Figure 4 for the Type 1301G regulator unless otherwise indicated.

1. Screw the orifice (key 5) into the regulator.
2. Insert both halves of the yoke (key 4) into the regulator, and fasten them together with the screws (key 17). The yoke halves are a matched set and need to be kept together.
3. The valve disk assembly (key 6) has two valve disks, one on each end. Inspect both valve disks, and select the one to be used. Thread the valve disk assembly into the yoke so that the disk to be used is positioned against the orifice. Thread the valve disk collar (key 22) onto the exposed end of the valve disk assembly.
4. Place the bottom cap O-ring (key 14) on the bottom cap (key 3). Place the spring (key 10) in the bottom cap, and thread it into the regulator.
5. Put the body gasket (key 12) on the regulator body (key 1).
6. Refer to Figure 5. Place the diaphragm plate gasket (key 13), two diaphragms (key 7), and the diaphragm plate (key 8) on the yoke (key 4). Make sure the diaphragm convolutions are toward the spring, and secure the parts by threading the diaphragm locknut (key 19) onto the yoke.
7. Place the regulator spring (key 11) and upper spring seat (key 9) on the diaphragm plate.
8. Position the spring case (key 2) over the spring and on the regulator body. Orient the spring case vent or vents as necessary. Insert the cap screws (key 16), and tighten them only finger-tight.
9. Thread the adjusting screw and locknut (keys 15 and 18) into the spring case just far enough to slightly compress the spring. Securely tighten the cap screws (key 16), and refer to the Startup section for adjustment procedures.

Parts Ordering

When corresponding with your local Sales Office about this regulator, include the type number and all other

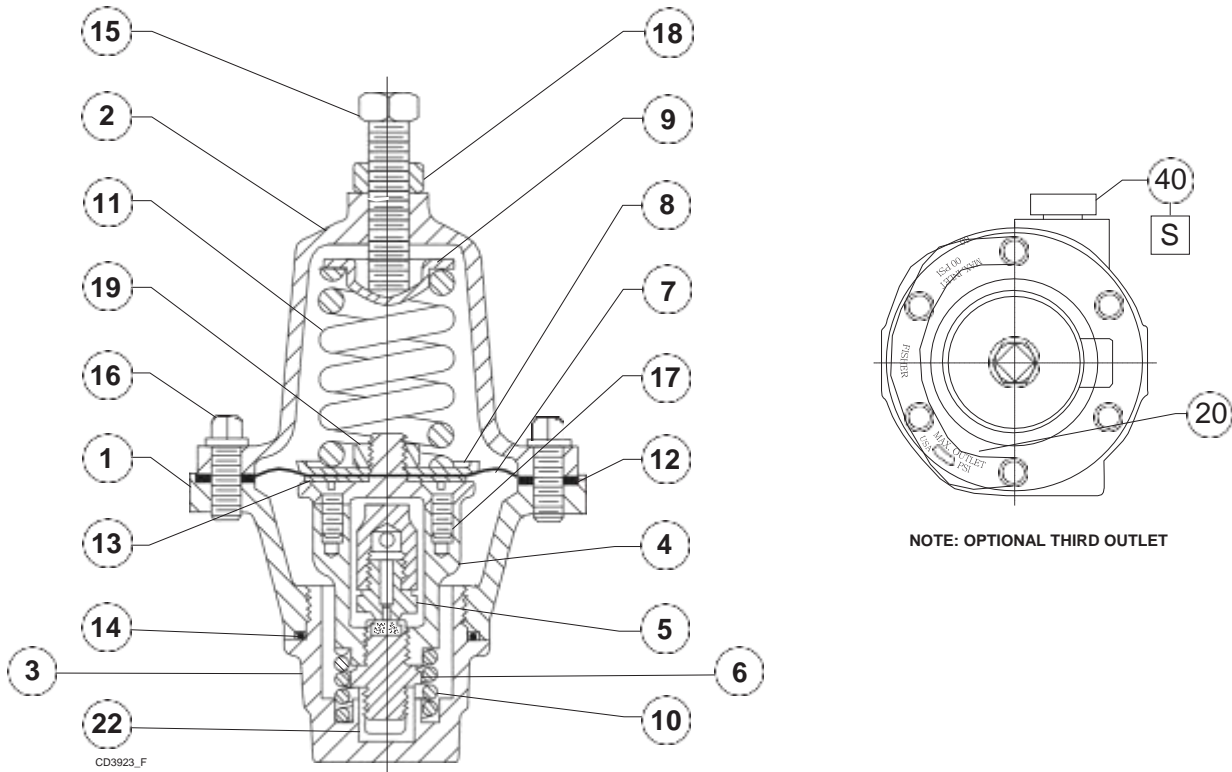

Figure 3. Type 1301F High-Pressure Regulator Assembly

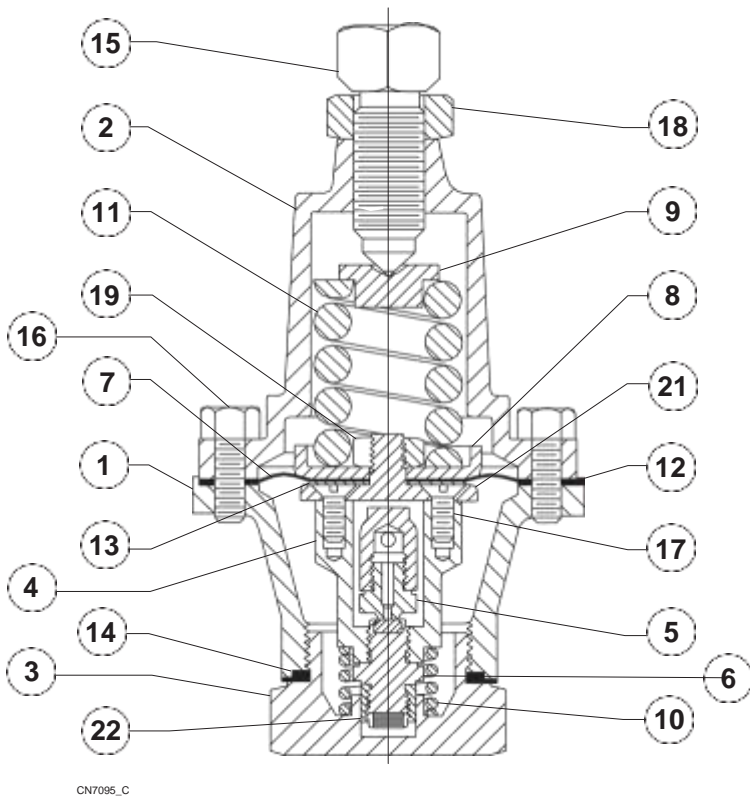

Figure 4. Type 1301G High-Pressure Regulator Assembly

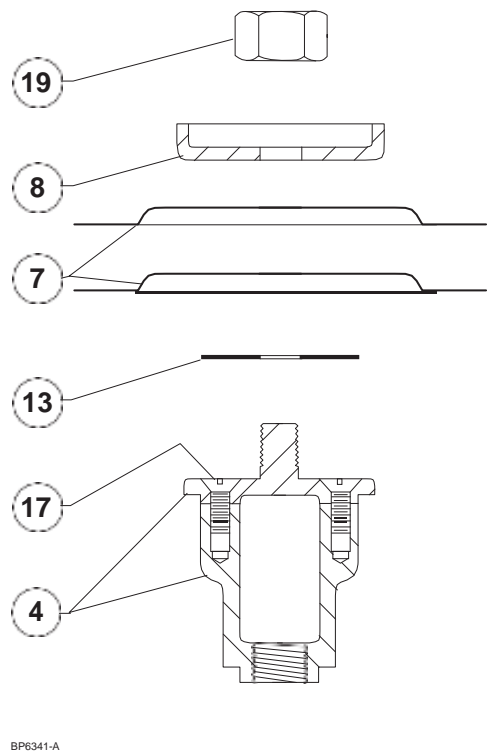

Figure 5. Exploded View of The Diaphragm Head Assembly and Yoke

pertinent information stamped on the bottom cap and on the nameplate. Specify the complete 11-character part number from the following parts list when ordering replacement parts.

Parts List

Note

Parts marked NACE in this parts list are intended for corrosion-resistant service as detailed in the NACE International Standards MR0175/ ISO 15156 and/or MR0103.

Key	Description	Part Number	Key	Description	Part Number
	Parts Kits (Includes keys 5, 6, 7, 12, 13 and 14) Stainless steel kits include Fluorocarbon (FKM) gaskets. Brass kits include Neoprene (CR) gaskets.		2	Spring Case (continued) Type 1301G 1/8 NPT vent connection Standard or with T-Handle Brass 316 Stainless steel	2P195713022 21A6377X012
	Brass With Nylon (PA) Disk Stainless steel With Nylon (PA) Disk	R1301FX0012	3	Bottom Cap Brass 304 Stainless steel 316 Stainless steel (NACE)	1D468513012 1J919635072 1J9196X0032
	Brass With PTFE Disk Stainless steel With PTFE Disk	R1301FX0032	4	Yoke Brass 316 Stainless steel (NACE)	1D383313012 1J925936042
1	Body 1/4 NPT Connection Brass (2 outlet port) Brass (3 outlet port) CF8M Stainless steel (2 outlet port) CF8M Stainless steel (3 outlet port) 1/4 x 1/2 in. Flanged Connection CF8M Stainless steel CL300 RF CL600 RF CL1500 RF PN 25 1/4 x 1 in. Flanged Connection CF8M Stainless steel CL300 RF CL600 RF CL1500 RF PN 25 Body (Cold Temperature) 1/4 NPT Connection CF8M Stainless steel (2 outlet port) CF8M Stainless steel (3 outlet port) NPS 1/4, NPT Connection	39A1342X012 ERAA00584A0 32B4291X022 ERAA00603A0	5*	Orifice 303 Stainless steel 316 Stainless steel (NACE)	1D386535032 1D3865X0032
			6*	Valve Disk Assembly Brass/Nylon (PA) Brass/PTFE 303 Stainless steel/Nylon (PA) 303 Stainless steel/PTFE 316 Stainless steel/PTFE (NACE)	1D4684000A2 1D4684X0012 1D4684000C2 1D4684000B2 1D4684X0082
			7*	Diaphragm (2 required) 302 Stainless steel Monel® (NACE)	1D387036012 1D3870X0012
			8	Diaphragm Plate, Zinc-plated steel Type 1301F Type 1301G	1D387325072 1K155725072
			9	Upper Spring Seat, Steel Type 1301F Type 1301G	1B798525062 1K155828982
			10	Valve Spring 302 Stainless steel Inconel® X750 (NACE)	1D387137022 15A3522X012
			11	Spring, Zinc-plated steel Type 1301F 0 to 75 psig / 0 to 5.2 bar, Blue 0 to 150 psig / 0 to 10.3 bar, Silver 0 to 225 psig / 0 to 15.5 bar, Red Type 1301G 200 to 500 psig / 13.8 to 34.5 bar, Silver	1D387227022 1B788527022 1D465127142
			12*	Body Gasket Neoprene (CR) Fluorocarbon (FKM)	1D372903012 1D372904122
			13*	Diaphragm Plate Gasket Neoprene (CR) Fluorocarbon (FKM)	1D373003012 1D373004122
			14*	Bottom Cap O-ring Fluorocarbon (FKM) EPDM Nitrile (NBR) -65F Fluorosilicone (FVQM) -80F	1J926806382 1J9268X0022 1J9268X0012 ERAA03306A0
2	Spring Case Type 1301F Brass Standard or with T-Handle Stainless steel With 1/4 NPT vent connection	34B0527X012 ERAA00604A0	15	Adjusting Screw Type 1301F Steel (standard) Handwheel, 416 Stainless steel T-handle, Steel Type 1301G Zinc-plated steel (standard) T-handle, Steel	1E639928992 1N411435132 1F2236000A2 1K140624092 19A8060X012
			16	Spring Case Cap Screw (6 required) Zinc-plated steel Stainless steel Stainless steel (For Type 1301G Cold Temperature)	1E8220X0012 1E8220X0212 1E8220X0022

*Recommended spare part.
Monel® and Inconel® are trademarks of Special Metals Corporation.

Parts List (continued)

Key	Description	Part Number	Key	Description	Part Number
17	Machine Screw (2 required) Steel, for brass yoke 302 Stainless steel, for Stainless steel yoke	1H526928982 1J926938992	29	Screw, Steel (Not shown) Type 1301F with handwheel and steel spring case only	1E985428982
18	Locknut Type 1301F Brass (for standard spring case) Steel (for Stainless steel spring case) Type 1301G Zinc-plated steel	1A518014012 1A352224122 1A354024122	30	Washer, Steel (Not shown) Type 1301F with handwheel and steel spring case only	1L449428982
19	Diaphragm Locknut, Aluminum	1A309324122	32	Mounting Bracket (Not shown) Yoke mounted Casing mounted	22A6305X012 1U9284X0012
21	Top Connector, 316 Stainless steel Use with Stainless steel yoke only	1J926035072	33	Bracket Cap Screw (2 required) Use with key 32 (Not shown)	1C631224052
22	Valve Disk Collar 304 Stainless steel 316 Stainless steel (NACE)	1D468635032 1D4686X0012	34	Bracket Mounting Washer Use with key 32 (Not shown)	T12861T0012
24	Handwheel (Not shown) Type 1301F	1L217544992	35	NACE Tag Use with NACE unit (Not shown)	-----
26	Vent Screen (Not shown) Type 1301F, 18-8 Stainless steel Type 1301G, 304 Stainless steel	0L078343062 0W086343062	36	Tag Wire Use with key 35 (Not shown)	-----
27	Mounting Post (3 required) (Not shown) Type 1301F T-handle panel mounting only, 316 Stainless steel Type 1301G panel mounting only, Steel	1F2449X0022 1L2629X0012	38*	Body O-ring (Not shown) Use with -65°F / -54°C Cold Service Unit Use with -80°F / -62°C Cold Service Unit	ERAA03305A1 ERAA03305A0
28	Mounting Screw, Brass (3 required) Use with key 27 (Not shown)	0V070414012	39*	Top Connector O-ring (Not shown) Use with -65°F / -54°C Cold Service Unit Use with -80°F / -62°C Cold Service Unit	14B8848X012 ERAA03307A0
			40	Pipe Plug (Not shown) Brass Stainless steel	1C333528992 1C3335X0012

*Recommended spare part.