

# 630 Series Regulators and Relief Valves

## Introduction

### Scope of Manual

This Instruction Manual provides operating, installation, maintenance and parts information for the 630 Series regulators and relief valves.

### Description

The 630 Series consists of self-operated, spring loaded Type 630 **Big Joe**® pressure regulators and Type 630R relief valves, which are designed for maximum inlet pressures to 1500 psig / 103 bar and outlet pressures from 3 to 500 psig / 0.21 to 34.5 bar.

### Installation

#### ! WaRnIng

**Personal injury, property damage, equipment damage or leakage due to escaping gas or bursting of pressure-containing parts may result if this regulator is overpressured or is installed where service conditions could exceed the limits given in Specifications section, Tables 1 through 3 or where conditions exceed any ratings of the adjacent piping or piping connections.**

**To avoid such injury or damage, provide pressure-relieving or pressure-limiting devices (as required by the appropriate code, regulation or standard) to prevent service conditions from exceeding those limits.**



W1934

*Figure 1. Spring-Loaded Type 630 Regulator*

**Additionally, physical damage to the regulator could cause personal injury or property damage due to escaping gas. To avoid such injury or damage, install the regulator in a safe location.**

Before installing, inspect the unit for any damage and any foreign material. The regulator or relief valve may be mounted in any position, however, ensure that the flow direction corresponds with the direction of the arrow on the nameplate. Apply a good grade of pipe compound to the male threads of the pipeline.

## Specifications

The Specifications section lists the specifications for the 630 Series constructions.

### Available Configurations

**Type 630:** Spring-loaded reducing regulators

**Type 630R:** Spring-loaded relief valves

### Body Size

1 and 2 in. / DN 25 and 50

### End Connection Style

NPT, ASME CL150 RF, CL300 RF or CL600 RF

### Maximum allowable Inlet Pressures<sup>(1)</sup>

**Type 630 Regulators:** See Table 1

**Type 630R Relief Valves:** See Table 3

### Type 630 Outlet Pressure Ranges<sup>(1)</sup>

3 to 500 psig / 0.21 to 34.5 bar with intermediate values shown in Table 2

### Type 630R Relief Pressure Ranges<sup>(1)</sup>

3 to 250 psig / 0.21 to 17.2 bar

See Table 3

### Maximum allowable Outlet Pressures<sup>(1)</sup>

See Table 2

### Maximum allowable Pressure Drops<sup>(1)</sup>

See Table 1

### Pressure Registration

Internal

### Spring Case Vent

1/4 NPT

### Material Temperature Capabilities<sup>(1)</sup>

**Standard:** -20 to 180°F / -29 to 82°C

**Optional:** -20 to 300°F / -29 to 149°C

### Orifice Sizes

1/8, 3/16, 1/4, 3/8 or 1/2 in. /

3.18, 4.76, 6.35, 9.53 or 12.7 mm

### Coefficients for Relief Valve Sizing

ORIFICE SIZE		C <sub>g</sub>	C <sub>v</sub>	C <sub>t</sub>
In.	mm			
1/8	3.18	13.9	0.49	28.4
3/16	4.76	31.3	1.11	28.2
1/4	6.35	55.1	2.03	27.2
3/8	9.53	122.5	4.61	26.6
1/2	12.7	216.0	8.18	26.4

### approximate Weights

**1 In. End Connection:** 25 lbs / 11.3 kg

**2 In. End Connection:** 30 lbs / 13.6 kg

1. The pressure/temperature limits in this Instruction Manual or any applicable standard limitation should not be exceeded.

## Vents

### ! WaRning

**When the unit is installed in an enclosed area or indoors, escaping gas may accumulate and be an explosion hazard. Under these conditions the vent should be piped away from the unit to a freely ventilated outdoor location away from air intakes, windows, etc. Protect all vent openings against weather or the entrance of any foreign material that may plug the vent or affect operation of the regulator or relief valve. Inspect all vent openings periodically to be sure they are not plugged. If the vent is in an environment where freezing rain, ice or snow could clog the vent, it is recommended that a weatherproof vent be used.**

Spring-loaded constructions have a screened vent assembly (key 27, Figures 4, 5 and 6) installed in the 1/4 NPT spring case vent opening. If a remote vent is required, remove the vent assembly and install a remote vent line.

## Overpressure Protection

As is the case with most regulators, the Type 630 spring-loaded regulators have outlet pressure ratings that are lower than the inlet pressure ratings. Overpressure protection must be provided if the actual inlet pressure can exceed the outlet pressure rating. Overpressure protection is also required for the loading regulator and main regulator spring case of relief valves.

Refer to the following tables to determine pressure ratings:

- Spring-loaded Type 630 regulators.
  - Inlet pressure and pressure drop—Table 1.
  - Outlet pressure—Table 2.
- Spring-loaded Type 630R relief valve pressure Table 3.

### ! WaRning

**Overpressuring any portion of this equipment may cause damage to regulator parts, leaks in the regulator or personal injury due to bursting of pressure-containing parts or explosion of accumulated gas.**

**Table 1. Maximum Allowable Inlet Pressures and Pressure Drops**

ORIFICE SIZE		MAXIMUM ALLOWABLE INLET PRESSURE <sup>(1)</sup>		MAXIMUM ALLOWABLE PRESSURE DROP							
				nylon (PA) <sup>(2)</sup> and Polytetrafluoroethylene (PTFE) Disk		fluorocarbon (FKM) Disk		nitrile (NBR) <sup>(2)</sup> Disk			
in.	mm	psig	bar	psig	bar	psig	bar	psig	bar		
1/8 and 3/16	3.2 and 4.8	1500	103	1500	103	200	13.8	600	41.4		
1/4	6.4			1000	69						
3/8	9.5	1000	69	500	34.5					500	34.5
1/2	13	750	51.7	250	17.2					250	17.2

Note: Maximum inlet pressure not exceeded 1500 psig / 103 bar.

1. Inlet pressure must not exceed the sum of the actual outlet pressure setting and the maximum allowable pressure drop. For example, with an outlet pressure setting of 200 psig / 13.8 bar and a 3/8 in. / 9.5 mm orifice with a maximum allowable pressure drop of 500 psid / 34.5 bar d, the maximum inlet pressure is 700 psig / 48.3 bar.

2. Nitrile (NBR) valve disks are normally furnished for pressure drops to 200 psi / 13.8 bar, differential. For better erosion resistance, Nylon (PA) valve disks are normally furnished for higher pressure drops. Some erosion of valve disks occurs at all pressure drops due to solid particles in the flow stream. The rate of erosion is higher with large amounts of impurities in the flow stream and with high pressure drops. Valve disks and other regulator parts must be inspected periodically for erosion and damage and must be replaced as necessary.

**Table 2. Type 630 Regulator Outlet Pressure Ranges and Maximum Outlet Pressures**

REGULATOR CONSTRUCTION	OUTLET PRESSURE RANGE		SPRING PART NUMBER	MAXIMUM OPERATING OUTLET PRESSURE		MAXIMUM OUTLET PRESSURE OVER SETPOINT <sup>(1)</sup>		MAXIMUM EMERGENCY OUTLET (CaSing) PRESSURE <sup>(4)</sup>	
	psig	bar		psig	bar	psig	bar	psig	bar
Low-Pressure	3 to 10	0.21 to 0.69	0W019227022	10	0.69	20	1.38	66	4.55
	8 to 20	0.55 to 1.38	0W019127022	20	1.38				
	17 to 30	1.17 to 2.07	0W019027022	30	2.07	20 <sup>(2)</sup>	1.38 <sup>(2)</sup>		
	27 to 40	1.86 to 2.76	0Y066427022	40	2.76	Limited by Maximum Emergency Outlet Pressure			
High-Pressure	27 to 50	1.86 to 3.45	0W019227022	50	3.45	200	13.8	550	37.9
	46 to 95	3.17 to 6.55	0W019127022	95	6.55				
	90 to 150	6.21 to 10.3	0W019027022	150	10.3				
	150 to 200	10.3 to 13.8	0Y066427022	200	13.8				
	200 to 275	13.8 to 19.0	1J146927142	275	19.0				
	275 to 500	19.0 to 34.5	1K370927082	500	34.5	200 <sup>(3)</sup>	1.38 <sup>(2)</sup>		

1. Damage to internal parts of the regulator may occur if outlet pressure exceeds the actual pressure setting by amounts greater than those shown in this column.

2. For outlet pressure settings to 25 psig / 1.72 bar only. For pressure settings over 25 psig / 1.72 bar, outlet pressure is limited by maximum emergency outlet pressure of 45 psig / 3.10 bar.

3. For outlet pressure settings to 350 psig / 24.1 bar only. For pressure settings over 350 psig / 24.1 bar, outlet pressure is limited by maximum emergency outlet pressure of 550 psig / 37.9 bar.

4. Leakage or bursting of pressure-containing parts may occur if outlet pressure exceeds these values.

**Table 3. Type 630R Relief Pressure Ranges**

RELIEF VALVE CONSTRUCTION	RELIEF (INLET) PRESSURE RANGE		PART NUMBER	MAXIMUM ALLOWABLE RELIEF (INLET) PRESSURE, psig / bar	MAXIMUM EMERGENCY INLET (CaSing) PRESSURE <sup>(4)</sup>	
	psig	bar			psig	bar
Low-Pressure	3 to 8	0.21 to 0.55	0W019227022 0W019127022 0W019027022 0Y066427022 1J146927142	Relief Pressure Setting Plus Maximum Allowable Buildup of 25 psig / 1.72 bar	75	5.17
	6 to 17	0.41 to 1.17				
	15 to 22	1.03 to 1.52				
	20 to 35	1.38 to 2.41				
	35 to 50	2.41 to 3.45				
High-Pressure	30 to 70	2.07 to 4.83	0W019127022 0W019027022 0Y066427022 1J146927142	Relief Pressure Setting Plus Maximum Allowable Buildup of 250 psig / 17.2 bar	550	37.9
	50 to 95	3.45 to 6.55				
	75 to 175	5.17 to 12.1				
	150 to 250	10.3 to 17.2				

1. Leakage or bursting of pressure-containing parts may occur if inlet pressure exceeds these values.

**To avoid overpressure, provide an appropriate overpressure protection device to ensure that none of the limits listed in Specifications section, Tables 1 through 3 will be exceeded.**

Regulator or relief valve operation below the limits specified in Specifications section, Tables 1 through 3 does not preclude the possibility of damage from external sources or from debris in the gas line. Inspect the regulator for damage after any overpressure condition.

## Startup

Starting up the unit consists of opening the upstream block valve, introducing gas pressure. Use gauges to monitor pressures during startup.

The range of allowable pressure settings is marked on the nameplate. If a pressure setting beyond the nameplate range is required, substitute an appropriate spring selected from Table 5. Be sure to change the nameplate to indicate the new pressure range.

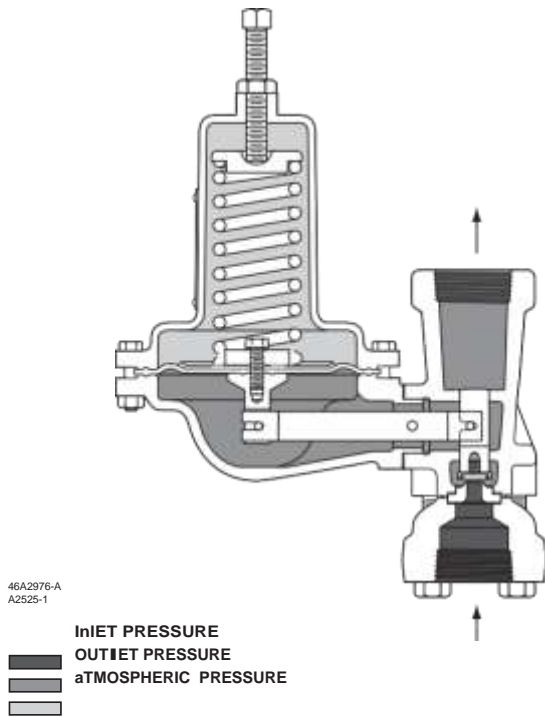

Figure 2. Type 630 Regulator Operational Schematic

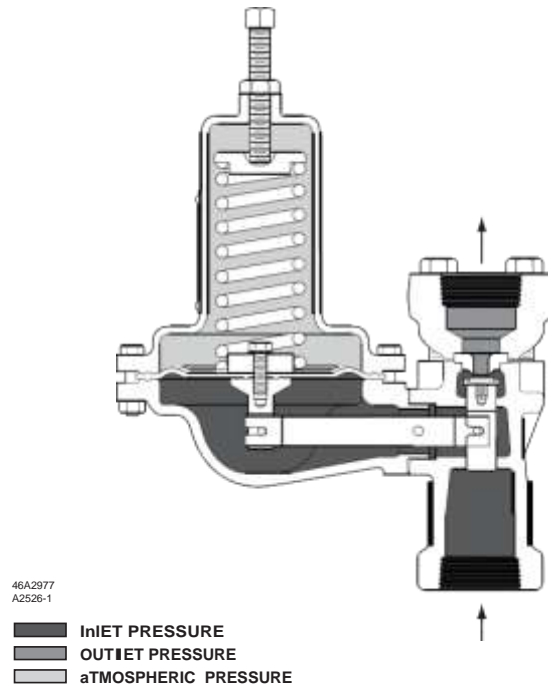

Figure 3. Type 630R Relief Valve Operational Schematic

**! WaRnIng**

**To avoid the consequences of over-tightening the spring in spring-loaded regulators or relief valves, consult Table 4 and replace the adjusting screw with one of the correct length when replacing the spring.**

Some pressure ratings are dependent upon the actual outlet pressure settings being used. For example, with a Type 630 regulator, outlet pressure must not exceed the setting by more than 20 psig / 1.38 bar for low pressure constructions or 200 psig / 13.8 bar for high pressure constructions or damage to internal regulator parts may occur. However, with some higher pressure ranges, the setting plus 20 psig / 1.38 bar or 200 psig / 13.8 bar exceeds the maximum emergency outlet (casing) pressure. Before increasing the setting, refer to Tables 2 and 3 (as appropriate). Review the pressure limits for the spring range being used and be certain that the new pressure setting will not result in an overpressure condition. Always use a pressure gauge to monitor pressure when making adjustments.

**adjusting Spring-Loaded Regulators and Relief Valves**

Loosen the hex nut (key 2, Figures 4, 5 and 6) atop the spring case. While monitoring the pressure, rotate the adjusting screw (key 1, Figures 4, 5 and 6) clockwise to increase set pressure or counterclockwise to decrease it. When the unit is regulating or relieving pressure at the desired value, tighten the hex nut.

**Shutdown**

Slowly close the upstream block valve.

**Principle of Operation**

This section describes the operation of the Type 630 regulator and the Type 630R relief valve with spring loading. Set pressure is changed with the adjusting screw on the regulator or relief valve. The Type 630R relief valve uses a light spring for added stability.

**Type 630 Regulators**

Refer to Figure 2. In the regulator construction, outlet pressure registers beneath the diaphragm. As long as the outlet pressure is less than the set pressure, spring force on the diaphragm causes the lever to hold

the valve open. When the outlet pressure exceeds the set pressure, the diaphragm moves to compress the spring and the lever closes the valve until the outlet pressure returns to set pressure.

## Type 630R Relief Valves

Refer to Figure 3. In the relief valve construction, inlet pressure registers beneath the diaphragm. As long as the inlet pressure is less than the set pressure, spring force causes the lever to hold the valve closed. When the inlet pressure exceeds the set pressure, the diaphragm moves to compress the spring and the lever opens the valve allowing inlet pressure to bleed into the downstream line or to atmosphere until the inlet pressure returns to set pressure.

## Maintenance

Parts are subject to normal wear and must be inspected and replaced as necessary. Frequency of inspection depends upon severity of service conditions.

### ! WaRnIng

**To avoid personal injury or equipment damage, isolate the regulator or relief valve from the pressure system and release all pressure from the regulator or relief valve before performing maintenance.**

Except where indicated, key numbers in the following procedures are shown in Figures 4 and 5 for the Type 630 regulator, in Figure 6 for the Type 630R relief valve.

## Replacing Orifice, Valve Disk and Lever

### note

**With some piping systems it may be possible to omit step 1 below by removing four cap screws (key 17) and spreading the body (key 23) and inlet adaptor (key 18) far enough apart to allow removal of the orifice (key 20) and Type 630 valve disk (key 21, Figures 4 and 5) or the orifice (key 20) and the Type 630R valve seat O-ring (key 37, figure 6).**

### CaUTION

**If step 1 is omitted and the body and inlet adaptor are separated, take care to avoid pinching fingers between the body and the inlet adaptor.**

1. Disconnect piping from inlet adaptor (key 18). Remove four cap screws (key 17) and adaptor.
2. Remove orifice (key 20) and gaskets (key 19).
3. To remove Type 630 valve disk (key 21, Figures 4 and 5) or Type 630R valve seat O-ring (key 37, Figure 6), first disconnect remote vent pipe (if one is used).
4. Unscrew the two cap screws (key 31, not shown) that secure diaphragm adaptor (key 13) to body (key 23); remove diaphragm adaptor and attached spring case (key 3).
5. If it is necessary to replace the lever (key 14), drive out the pin (key 15) and slide the lever out of the diaphragm adaptor. When replacing the lever, make sure the slot engages the connector assembly (key 12) and replace the pin.
6. Remove valve carrier assembly (key 22) from body.
7. To replace seating surface:
  - a. For Type 630, use a 3/4 in. / 19.1 mm socket wrench to remove and re-install valve disk and holder assembly (key 21, Figures 4 and 5).
  - b. For Type 630R, unscrew machine screw (key 36, Figure 6) and remove O-ring washer and O-ring (keys 32 and 37, Figure 6) from O-ring holder (key 21, Figure 6). When reassembling, apply a good-quality gasket shellac to the machine screw thread.
8. Use new orifice gaskets (key 19) and body gasket (key 16) when reassembling. Insert valve carrier assembly (key 22) into the body before re-installing the diaphragm adaptor.

### note

**The spring case (key 3) must point away from the inlet adaptor (key 18) on Type 630 regulators as shown in figures 4 and 5. On Type 630R relief valves, the spring case (key 3) must face the same direction as the inlet adaptor (key 18) as shown in figure 6.**



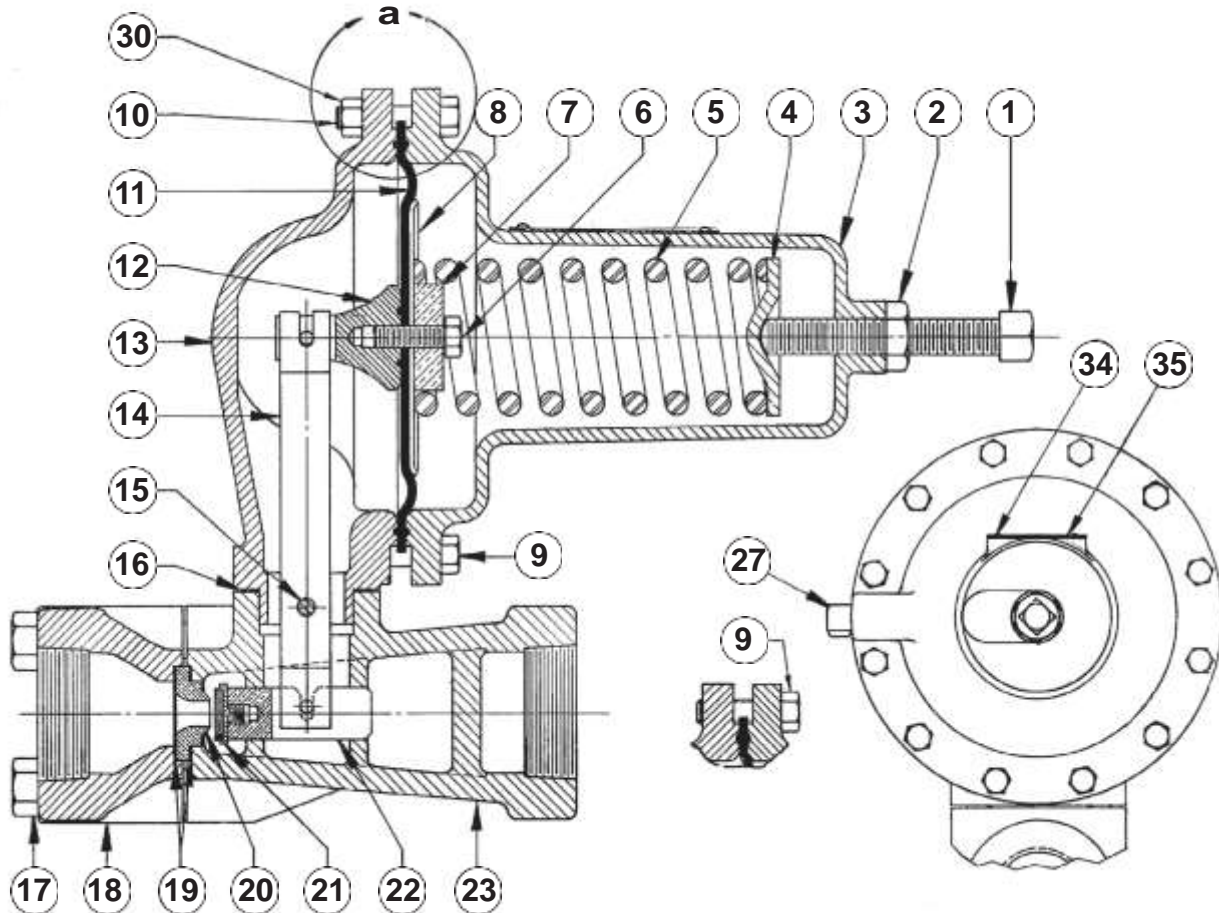

0X00119-F

**Figure 4. Spring-Loaded Type 630 Regulator - Low Pressure Construction**

9. Be certain the lever (key 14) engages the valve carrier.
10. Secure the diaphragm adaptor (key 13) to the body (key 23). Fit the inlet adaptor (key 18) to the body and install and tighten the four cap screws (key 17).

### Replacing the Diaphragm

1. To relieve spring compression, loosen hex nut (key 2, Figures 4, 5 and 6). Turn the adjusting screw (key 1, Figures 4, 5 and 6) counterclockwise until spring compression is relieved.
2. Disconnect remote vent line (if one is present).
3. Remove spring case (key 3) by unscrewing cap screws and nuts (keys 9, 10 and 30).
4. Remove diaphragm (key 11) and attached parts from the lever (key 14).

5. Unscrew cap screw (key 6) from connector head assembly (key 12) and disassemble the diaphragm assembly.
6. Install new diaphragm being certain that the diaphragm is centered. Note that low-pressure constructions use a diaphragm plate (key 8, Figure 5) on the spring case side of the diaphragm. Install new gaskets when replacing diaphragm.
7. When reassembling, be certain that the diaphragm connector is engaged in the lever.

#### note

**Be careful not to twist the diaphragm to lever attachment during assembly. Twisting will cause sufficient friction to interfere with the proper operation of the regulator.**

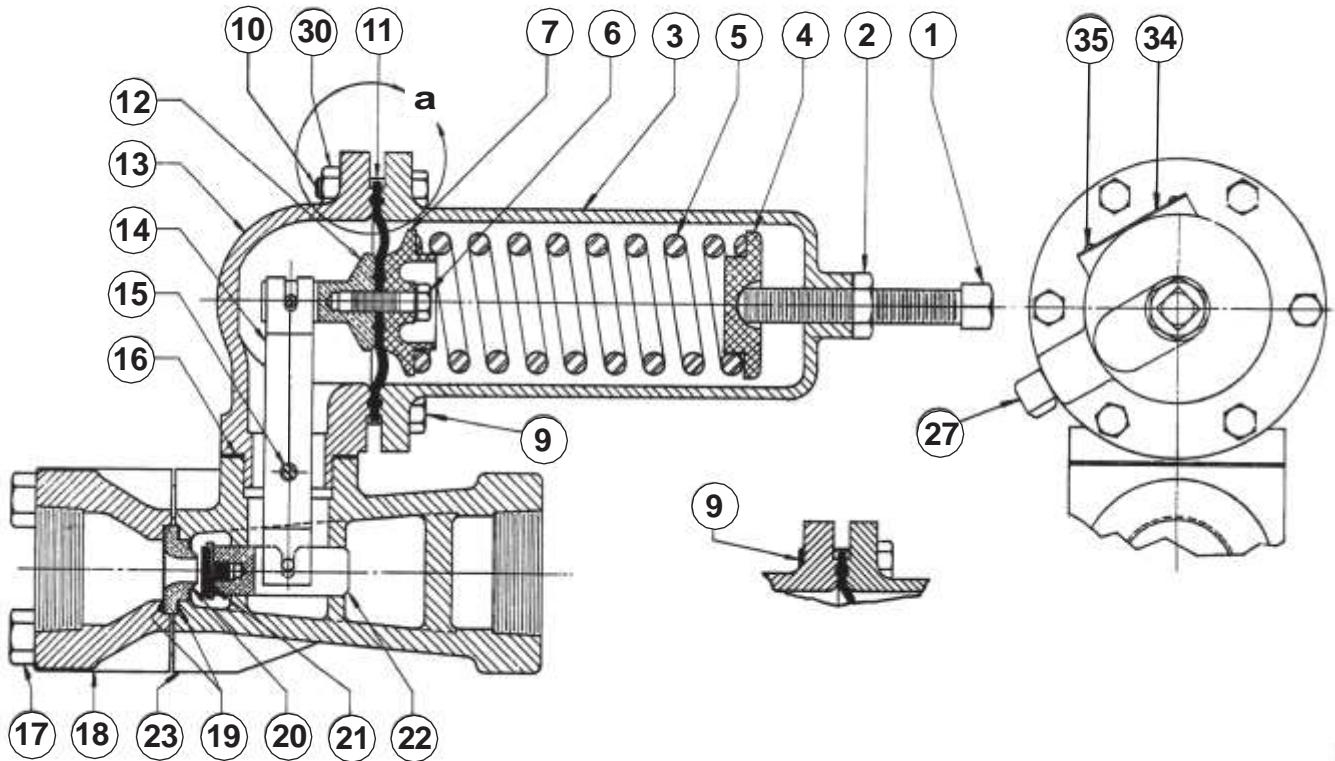

CB2197-E

**Figure 5. Spring Loaded Type 630 Regulator - High Pressure Construction**

- To ensure proper slack in the diaphragm, tighten the spring case cap screws finger-tight only. Compress the spring slightly with the adjusting screw then complete the tightening of the spring case cap screws and nuts.

## Parts Ordering

The type number orifice size, spring range and date of manufacture are stamped on the nameplate. Always provide this information in any correspondence with your local Sales Office regarding replacement parts or technical assistance.

When ordering replacement parts, reference the key number of each needed part as found in the following parts list. Separate kit containing all recommended spare parts is available.

## Parts list

### note

**In this parts list, parts marked naCE are intended for corrosion-resistant service as detailed in the naCE International Standard MR0175.**

## Parts Kits

Type 630 regulator kits are for low or high pressure spring-loaded construction. Kits include neoprene diaphragm, copper inlet gasket material (for brass trim) or composition material (for stainless trim) and valve disk assembly material as noted. Orifice included only where indicated. If separate orifice is required, must be ordered separately by appropriate part number based on orifice size and material. (Included are keys 11, 16, 19, 21 and 20).

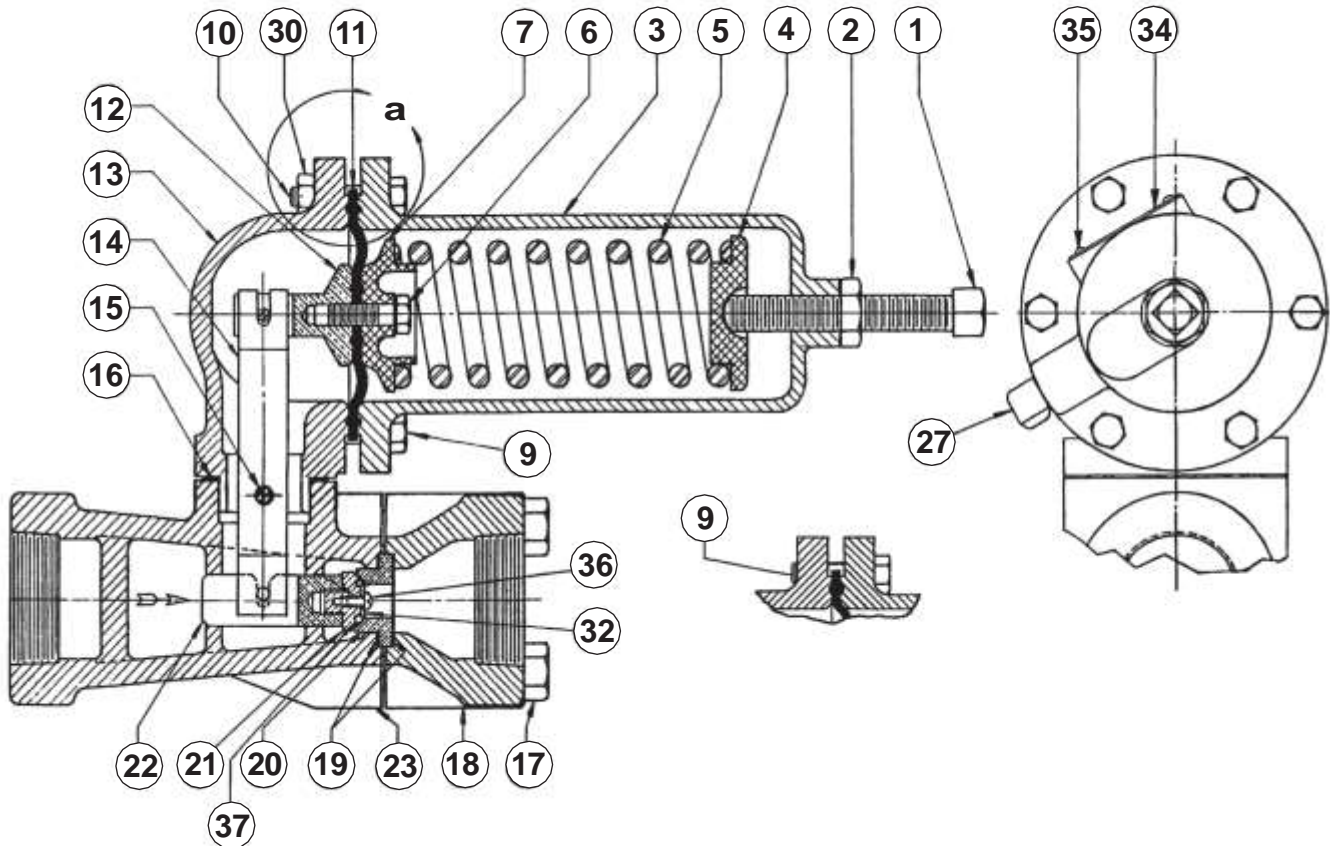

CD3355-E

**Figure 6. Spring-Loaded Type 630R Relief Valve High-Pressure Construction**

Key	Description	Part number	Key	Description	Part number
	Low Pressure			High Pressure (continued)	
	Without orifice			With orifice (key 20)	
	Brass/Nitrile (NBR)	R630X000L12		1/8 in. / 3.18 mm Brass/Nylon (PA)	R630X000HC2
	Brass/Nylon (PA)	R630X000L22		1/8 in. / 3.18 mm	
	Brass/PTFE	R630X000L32		Stainless steel/Nylon (PA) ( <b>standard</b> )	R630X000HD2
	Stainless steel/Nitrile (NBR)	R630X000L42		1/8 in. / 3.18 mm	
	Stainless steel/Nylon (PA) ( <b>standard</b> and NACE)	R630X000L52		Stainless steel/Nylon (PA) (NACE)	R630X000HND2
	Stainless steel/PTFE	R630X000L62		1/4 in. / 6.35 mm Brass/Nylon (PA)	R630X000HA2
	With orifice (key 20)			1/4 in. / 6.35 mm	
	1/2 in. / 12.7 mm Brass/Nylon (PA)	R630X000LA2		Stainless steel/Nylon (PA) ( <b>standard</b> )	R630X000HB2
	1/2 in. / 12.7 mm Stainless steel/Nylon (PA)	R630X000LB2		1/4 in. / 6.35 mm	
	High Pressure			Stainless steel/Nylon (PA) (NACE)	R630X000HNB2
	Without orifice			Type 630R Relief Valve retrofit kit converts	
	Brass/Nitrile (NBR)	R630X000H12		Type 630 to a Type 630R. (Included are	
	Brass/Nylon (PA)	R630X000H22		keys 16, 19, 20, 21, 32, 34, 35 <sup>(1)</sup> , 36 and 37)	
	Brass/PTFE	R630X000H32			
	Stainless steel/Nitrile (NBR)	R630X000H42			
	Stainless steel/Nylon (PA) ( <b>standard</b> and NACE)	R630X000H52		1/2 in. / 12.7 mm Brass/Nitrile (NBR)	R630RX00B12
	Stainless steel/PTFE	R630X000H62		1/2 in. / 12.7 mm Stainless steel/Nitrile (NBR)	R630RX00S12

1. Drive screw (key 35) not included in R630RX00S12 kit.



Key	Description	Part number	Key	Description	Part number
1	Adjusting Screw, Steel	See Table 4	15	Pin Stainless steel Stainless steel (NACE)	0W018835172 0W0188X0022
2	Hex Nut, plated steel	1A352424122	16*	Gasket, Composition	0W018704022
3	Spring Case Low-pressure Cast iron Steel High-pressure Cast iron Steel	3C780919042 3N698122012 3C780819042 3N698322012	17	Cap Screw, steel (4 required) 1 in. / DN 25 body 2 in. / DN 50 body	1A935924052 11A7202X022
4	Upper Spring Seat, Zinc Pressure range to 275 psig / 19.0 bar Pressure range over 275 psig / 19.0 bar	16A9812X012 16A9813X012	18	Inlet Adaptor, Steel Body Cast Iron 1 NPT 2 NPT Steel 1 NPT 1 NPT (NACE) 2 NPT 2 NPT (NACE) CL150 RF 1 in. / DN 25 2 in. / DN 50 2 in. / DN 50 (Type 630R only) CL300 RF 1 in. / DN 25 2 in. / DN 50 2 in. / DN 50 (Type 630R only) CL600 RF 1 in. / DN 25 2 in. / DN 50 2 in. / DN 50 (Type 630R only)	1F479823022 1F479923022 1F479823022 1F4798X0022 1F479923022 1F4799X0022 12A3803X012 27B0495X012 28B6247X012 12A3633X012 27B0488X012 28B6248X012 18A7701X012 27B0498X012 28B6249X012
5	Spring, steel	See Table 5	19*	Inlet Body Gasket (2 required) Copper, for Brass trim Composition, for Stainless steel trim	0W018415042 0W018404022
6	Cap Screw, plated steel	1R817699012	20*	Orifice Type 630 Brass 1/8 in. / 3.18 mm 3/16 in. / 4.76 mm 1/4 in. / 6.35 mm 3/8 in. / 9.53 mm 1/2 in. / 12.7 mm Stainless steel 1/8 in. / 3.18 mm 3/16 in. / 4.76 mm 1/4 in. / 6.35 mm 3/8 in. / 9.53 mm 1/2 in. / 12.7 mm Stainless steel (NACE) 1/8 in. / 3.18 mm 3/16 in. / 4.76 mm 1/4 in. / 6.35 mm 3/8 in. / 9.53 mm 1/2 in. / 12.7 mm Type 630R Brass 1/2 in. / 12.7 mm Stainless steel 1/2 in. / 12.7 mm Stainless steel (NACE) 1/2 in. / 12.7 mm	0Z040014012 1B219514012 0W018314012 0W018214012 0W018114012 1K416635032 1K416535032 1K416435032 1K416335032 1K416235032 1K4166X0012 1K4165X0012 1K4164X0012 1K4163X0012 1K4162X0012 1B735014012 1B735035032 1K4162X0012
7	Lower Spring Seat Low-pressure, Steel High-pressure, Zinc Pressure range to 275 psig / 19.0 bar Pressure range over 275 psig / 19.0 bar	0W020324102 0W020144022 1K371044022			
8	Diaphragm Plate, Zinc-plated steel Low-Pressure only (1 required)	0W020225072			
9	Cap Screw, Zinc-plated steel For use with steel diaphragm adaptor For low-pressure regulator (10 required) For high-pressure regulator (4 required)	1C379124052 1B787724052			
10	Cap Screw, plated steel (for use with cast iron diaphragm adaptor) Low-pressure (10 required) High-pressure (4 required)	1A352524052 1A352524052			
11*	Diaphragm Neoprene (CR) For low-pressure regulator For high-pressure regulator Fluorocarbon (FKM) For low-pressure regulator (2 required) For high-pressure regulator (2 required)	0W020002192 0W019902192 0W0200X0022 0W019902402			
12	Connector Head Assembly Aluminum trim Aluminum trim (NACE) Stainless steel trim Stainless steel trim (NACE)	16A9811X012 16A9811X032 1P8465000B2 1P8465X0012			
13	Diaphragm Adaptor Low-pressure Cast iron Steel Steel (NACE) High-pressure Cast iron Steel Steel (NACE)	0W019719012 2N698522012 2N6985X0072 0W019819012 2N698722012 2N6987X0042			
14	Lever Assembly, Steel or Stainless steel Low-pressure Low-pressure (NACE) High-pressure High-pressure (NACE)	1B2891000A2 1B2891X0032 1B2890000A2 1B2890X0022			

\*Recommended spare part.

Key	Description	Part number	Key	Description	Part number
21*	Valve Disk Assembly (Type 630 only) For pressure ranges to 200 psig / 13.8 bar Brass holder, Polyurethane (PU) disk Stainless steel holder, Polyurethane (PU) disk Brass holder, Fluorocarbon (FKM) disk Stainless steel holder, Fluorocarbon (FKM) disk	1P7351X0012 1P7351000A2 1B4500X0042 1B4500X0012	27	Vent Assembly, Type Y602-12	27A5516X012
	For pressure ranges over 200 psig / 13.8 bar Brass holder, Nitrile (NBR) disk Stainless steel holder, Nitrile (NBR) disk Brass holder, Nylon (PA) disk Stainless steel holder, Nylon (PA) disk Brass holder, PTFE disk Stainless steel holder, Nitrile (NBR) disk Stainless steel holder, PTFE disk	1B4500000A2 1B4500000B2 1C1860000A2 1C1860000B2 1C1860000C2 1B4500X0072 1C1860000D2	30	Hex Nut, Zinc-plated steel, (used only with Cast iron diaphragm adaptor, key 13) Low-pressure (10 required) High-pressure (4 required)	1A352724122 1A352724122
	NACE construction For pressure ranges to 200 psig / 13.8 bar Stainless steel holder, Fluorocarbon (FKM) disk For pressure ranges above 200 psig / 13.8 bar Stainless steel holder, Nylon (PA) disk Stainless steel holder, PTFE disk Stainless steel holder, Nitrile (NBR) disk	1B4500X0082 1C1860000B2 1C1860000D2 1B4500X0072	31	Cap Screw, plated steel (2 required) (not shown)	1A341824052
21	O-ring Holder (Type 630R) Brass Stainless steel Stainless steel (NACE)	1D336014012 1D336035032 1D3360X0012	32	O-ring Washer (For Type 630R only) Brass Stainless steel Stainless steel (NACE)	1D335914012 1D335935072 1D3359X0012
22	Valve Carrier Brass Stainless steel Stainless steel (NACE)	0W018614022 0W018635032 0W0186X0022	33	Plug, plated steel (not shown) For 2 in. / DN 50 bodies only	1D8293T0022
23	Body Cast Iron 1 NPT 2 NPT Steel 1 NPT 1 NPT (NACE) 2 NPT 2 NPT (NACE) CL150 RF 1 in. / DN 25 2 in. / DN 50 2 in. / DN 50 (Type 630R only) CL300 RF 1 in. / DN 25 2 in. / DN 50 2 in. / DN 50 (Type 630R only) CL600 RF 1 in. / DN 25 2 in. / DN 50 2 in. / DN 50 (Type 630R only)	0W0209000A2 0W021519012 2N6990000A2 2N6990X0092 2N699122012 2N6991X0032 27B3333X012 27B3336X012 28B6244X012 27B3334X012 27B3337X012 28B6245X012 27B3335X012 27B3338X012 28B6246X012	34	Nameplate, Aluminum Type 630 Type 630R	1F7496X0072 21A5495X062
			35	Drive Screw, Stainless steel (4 required)	1A368228982
			36	Machine Screw Type 630R only Stainless steel	1A5733X0012
			37*	O-ring Type 630R only Nitrile (NBR) PTFE Nitrile (NBR) (NACE) PTFE (NACE)	1D288806992 1F581906522 1D288806992 1F581906522
			43	Diaphragm protector, PTFE (not shown) (use only when specified) High Pressure Low Pressure	1K881306242 1K881206242
			52	NACE Tag (not shown), 18-8 Stainless steel	19A6034X012
			53	Tag Wire (not shown), 303 Stainless steel	1U7581X0022

\*Recommended spare part.

**Table 4. Key 1, Adjusting Screw, Steel**

Type	SPRING PART NUMBER	ADJUSTING SCREW PART NUMBER	ADJUSTING SCREW PART NUMBER (WIRE SEAL)	LENGTH OF THREADED PORTION	
				In.	mm
630	0W019227022	1A279128982	1R829928992	4	102
	0W019127022	1B212028982	1R830028992	3-1/2	88.9
	0W019027022	1A500528982	1R8085T0012	3	76.2
	0Y066427022	1A500528982	1R8085T0012	3	76.2
	1J146927142	1A500528982	1R8085T0012	3	76.2
	1K370927082	1A500528982	1R8085T0012	3	76.2
630R	0W019227022	1A279128982	1R829928992	4	102
	0W019127022	1B212028982	1R830028992	3-1/2	88.9
	0W019027022	1A500528982	1R8085T0012	3	76.2
	0Y066427022	1D336628982	1R830128992	3-1/4	82.6
	1J146927142	1D336628982	1R830128992	3-1/4	82.6

**Table 5. Key 5, Regulator Spring, Steel**

Type		OUTLET (OR RELIEF) PRESSURE SETTING		SPRING PART NUMBER	SPRING COLOR CODE
		psig	bar		
Spring-Loaded Type 630	Low-Pressure	3 to 10	0.21 to 0.69	0W019227022	Red Stripe
		8 to 20	0.55 to 1.38	0W019127022	Olive Drab
		17 to 30	1.17 to 2.07	0W019027022	Silver
		27 to 40	1.86 to 2.76	0Y066427022	Green Stripe
	High Pressure	27 to 50	1.86 to 3.45	0W019227022	Red Stripe
		46 to 95	3.17 to 6.55	0W019127022	Olive Drab
		90 to 150	6.21 to 10.3	0W019027022	Silver
		150 to 200	10.3 to 13.8	0Y066427022	Green Stripe
	200 to 275	13.8 to 19.0	1J146927142	Blue Stripe	
	275 to 500	19.0 to 34.5	1K370927082	Yellow Stripe	
Spring-Loaded Type 630R	Low-Pressure	3 to 8	0.21 to 0.55	0W019227022	Red Stripe
		6 to 17	0.41 to 1.17	0W019127022	Olive Drab
		15 to 22	1.03 to 1.52	0W019027022	Silver
		20 to 35	1.38 to 2.41	0Y066427022	Green Stripe
		35 to 50	2.41 to 3.45	1J146927142	Blue Stripe
	High Pressure	30 to 70	2.07 to 4.83	0W019127022	Olive Drab
		50 to 95	3.45 to 6.55	0W019027022	Silver
		75 to 175	5.17 to 12.1	0Y066427022	Green Stripe
150 to 250		10.3 to 17.2	1J146927142	Blue Stripe	