

R600 and HSRL Series Instruction Manual

! WARNING

Failure to follow these instructions or to properly install and maintain this equipment could result in an explosion and/or fire causing property damage and personal injury or death.

Fisher® equipment must be installed, operated and maintained in accordance with federal, state and local codes and Fisher instructions. The installation in most states must also comply with NFPA No. 54 and 58 standards.

Only personnel trained in the proper procedures, codes, standards and regulations of the LP-Gas industry should install and service this equipment.

Things to tell the gas customer:

1. Show the customer the vent or vent assembly or vent tube. Stress that this opening must remain unobstructed at all times. Tell the customer to check the vent opening after a freezing rain, sleet storm or snow to make sure ice has not formed in the vent.
2. Show the customer the shutoff valve on the container. The customer should close this valve immediately if gas is smelled, appliance pilot lights fail to stay on or appear higher than usual or any other abnormal situation occurs.
3. Tell the customer to call your company to service the regulator if the regulator vents gas or a leak develops in the system. Only a qualified gas service person should install or service the regulator.
4. Tell the customer to call your company to have a leak check performed if the gas supply has been shutoff or interrupted for any reason. A leak check must be performed by a qualified gas service person on the piping system immediately after turning on the gas supply.



TYPE R622



TYPE R642



TYPE HSRL

Figure 1. Types R622, R642 and HSRL Series Regulators

Introduction

Scope of the Manual

This Instruction Manual covers Installation and Maintenance for the R600 and HSRL Series regulators, which includes first stage, second stage, two psig service, integral two-stage and integral two psig service regulators used on LP-Gas vapor service applications. They are not to be used on liquid service.

Specifications

Specifications section, Tables 1 and 2 list the specifications for these regulators. Contact the factory if the regulator is to be used on any service other than LP-Gas, natural gas or air. The following information is located on the spring case: Type number, orifice size, spring range and date of manufacture.

Pressure Taps Size Restriction

R600 Series: 1/8 in. NPT: #54 (0.055 in. / 1.40 mm)
 Drill on outlet and inlet
HSRL Series: None

Orifice Sizes

R600 Series (Except R632A and R632E Series):
 7/32 in. / 5.6 mm
R632A and R632E Series: 0.256 in. / 6.5 mm
HSRL Series: 3/8 in. / 9.5 mm

Wide-open C_g for Relief Sizing

R600 Series: 38
HSRL Series: 105

Maximum Allowable Inlet Pressure⁽¹⁾

Types R622H, R632A and R632E: 250 psig / 17.2 bar
Types R622E and R652E: 10 psig / 0.69 bar
Types R622, R642, R652 and HSRL Series:
 10 psig / 0.69 bar

Maximum Emergency Inlet Pressure⁽¹⁾

Types R622H, R632A and R632E: 250 psig / 17.2 bar
Types R622E and R652E: 15 psig / 1.0 bar
Types R622 and R652: 50 psig / 3.4 bar
Type R642: 85 psig / 5.9 bar
Type HSRL: 30 psig / 2.1 bar

Temperature Capabilities⁽¹⁾

R600 and HSRL Series: -20 to 160°F / -29 to 71°C⁽²⁾

Pressure Registration

Internal

Outlet Pressure Standard Setpoint

Types R622, R642, R652 and HSRL Series:
 11 in. w.c. / 27 mbar
Type R632A:
First Stage: approximately 8 psig / 0.55 bar at
 75 psig / 5.2 bar, 65 SCFH / 1.84 Sm³/h
Second Stage: 11 in. w.c. / 27 mbar

Outlet Pressure Standard Setpoint (continued)

Type R632E:

First Stage: approximately 8 psig / 0.55 bar at
 75 psig / 5.2 bar, 65 SCFH / 1.84 Sm³/h
Second Stage: 2 psig / 0.14 bar

Types R622E and R652E: 2 psig / 0.14 bar

Type R622H: 10 psig / 0.69 bar, 5 psig / 0.34 bar

Outlet Pressure Spring Range

Types R622, R642 and R652:

7.5 to 9.5 in. w.c. / 19 to 24 mbar,
 9 to 13 in. w.c. / 22 to 32 mbar,
 13 to 20 in. w.c. / 32 to 50 mbar,
 16 to 40 in. w.c. / 40 to 99 mbar

Type R632A:

First Stage: non-adjustable
Second Stage: 9 to 13 in. w.c. / 22 to 32 mbar

Type R632E:

First Stage: non-adjustable
Second Stage: 1 to 2.2 psig / 69 mbar to 0.15 bar

Types R622E and R652E:

1 to 2.2 psig / 69 mbar to 0.15 bar
Type R622H: 8 to 12 psig / 0.55 to 0.83 bar,
 4 to 6 psig / 0.28 to 0.41 bar

HSRL Series: 9 to 13 in. w.c. / 22 to 32 mbar

Approximate Weight

Type R622H with POL Inlet:

1.7 lbs / 771 g

Types R632A and R632E with POL inlet:

2.9 lbs / 1310 g

Types R632A and R632E with NPT Inlet:

2.5 lbs / 1125 g

All Other R600 Series: 1.4 lbs / 635 g

HSRL Series: 4.5 lbs / 2.0 kg

1. The pressure/temperature limits in this Instruction Manual or any applicable standard limitation should not be exceeded.

2. Product has passed Fisher® testing for lockup, relief start-to-discharge and reseal down to -40°F / -40°C.

Description

First Stage and 2 psig / 0.14 bar Service Regulators

The Types R622H, R622E and R652E regulators are designed for high pressure (pounds per square inch) vapor service. These regulators have high capacity internal relief valves.

When used on first stage service, the Type R622H regulator reduces container pressure to 10 psig / 0.69 bar for a second stage regulator. On final stage service the regulator reduces container pressure for a high pressure burner. The regulator is normally painted RED.

The Type R622E or R652E standard outlet pressure setting is 2 psig / 0.14 bar. The regulator is painted PALM GREEN with a WHITE CAP. It is an intermediate stage regulator that reduces 10 psig / 0.69 bar first stage pressure to 2 psig / 0.14 bar. They are used on 2 psig / 0.14 bar pressure systems. The Types R622E and R652E are not suitable for first stage service.

Second Stage Low Pressure Regulators

The Types R622, R642, R652 and HSRL Series regulators provide low pressure (inches of water column) delivery pressures. They are normally set at 11 in. w.c. / 27 mbar pressure. They have high capacity internal relief valve construction. The regulators are normally painted PALM GREEN. The units differ in construction and capacity rating.

Integral Two-stage Regulator

The Type R632A integral two-stage regulator contains a non-adjustable first stage regulator on the inlet. The second stage provides 11 in. w.c. / 27 mbar outlet pressure. The second stage portion has a high capacity internal relief valve construction. The first stage does not have an internal relief valve. The regulators are normally painted GRAY with a BLACK CAP.

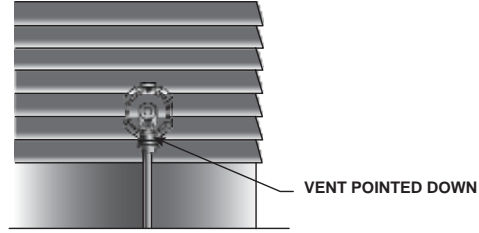

Integral Two psig Service Regulator

The Type R632E integral two psig service regulator contains a non-adjustable first stage regulator on the inlet. The second stage provides 2 psig / 0.14 bar outlet pressure. The second stage portion has a high capacity internal relief valve construction. The first stage does not have an internal relief valve. The regulators are normally painted GRAY with a WHITE CAP and White 2-psig STICKER.

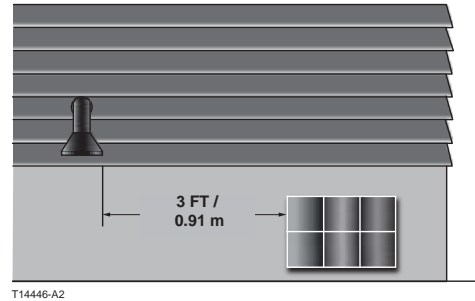

Figure 2. Regulator with Vent Pointed Down

Installation

! WARNING

All vents should be kept open to permit free flow of air in and out of the regulator. Protect vent openings against the entrance of rain, snow, ice formation, paint, mud, insects, water from an irrigation system or any other foreign material that could plug the vent or vent line or accumulate in the vent line.

LP-Gas may discharge to the atmosphere through the vent. An obstructed vent which limits air or gas flow can cause abnormally high pressure that could result in personal injury or property damage. Failure to use a vent line on Indoor Installations can cause a hazardous accumulation of gas which could result in personal injury or property damage.

Types R622H, R622E, R632A, R632E and R652E regulators are not suitable for indoor installations.

Never use a Type R622H, R622E, R632E or R652E (pounds-to-pounds) regulator on low pressure (inches of water column) service

because personal injury or property damage could occur. The Types R622E and R652E are not suitable for use as a “first stage” regulator.

General Installation Instructions

Before installing the regulator,

- Check for damage, which might have occurred in shipment.
- Check for and remove any dirt or foreign material, which may have accumulated in the regulator body.
- Replace old pigtailed. Blow out any debris, dirt or copper sulfate in the copper tubing and the pipeline.
- Apply pipe compound to the male threads of the pipe before installing the regulator.
- Make sure gas flow through the regulator is in the same direction as the arrow on the body. “Inlet” and “Outlet” connections are clearly marked.

Table 1. Relief Valve Specifications

TYPE	TYPICAL SETPOINT		NOMINAL RELIEF VALVE START-TO-DISCHARGE		MAXIMUM INLET PRESSURE TO NOT EXCEED OUTLET PRESSURE WITH DISC REMOVED			
	psig	bar	psig	bar	Inlet Pressure		Maximum Outlet Pressure	
					psig	bar	psig	bar
HSRL					15	1.0		
R622 and R642	11 in. w.c.	27 mbar	1	69 mbar	50	3.4	2	0.14
R652					250	17.2		
R632A ⁽¹⁾					250	17.2		
R632E ⁽¹⁾	2	0.14	3.5	0.24	50	3.4	5	0.34
R622E								
R652E								
R622H	10	0.69	20	1.37	Not Applicable			

1. For integral two-stage regulators, the second stage disc is removed.

Table 2. Capacity, Connection Sizes and Vent Orientation

REGULATOR APPLICATION	TYPE NUMBER	CAPACITY BTU/HR PROPANE ⁽¹⁾	INLET CONNECTION	OUTLET CONNECTION	OUTLET PRESSURE SETTING	3/4 IN. NPT SCREENED VENT STANDARD LOCATION
Second Stage	R622-BCF	875,000	1/2 in. FNPT	1/2 in. FNPT	11 in. w.c. / 27 mbar	Over Inlet
	R642-DFF	900,000	3/4 in. FNPT	3/4 in. FNPT		
	R652-DFF	1,000,000				
	R622-CFF	1,400,000	1/2 in. FNPT	3/4 in. FNPT		
	R622-DFF		3/4 in. FNPT			
	R622-CFGXA	1,125,000	1/2 in. FNPT	3/4 in. FNPT	18 in. w.c. / 45 mbar	
	HSRL-BFC ⁽²⁾	2,100,000	3/4 in. FNPT	1 in. FNPT	11 in. w.c. / 27 mbar	
HSRL-CFC ⁽²⁾	1 in. FNPT					
Integral Two-Stage	R632A-BCF	850,000	1/4 in. FNPT	1/2 in. FNPT	11 in. w.c. / 27 mbar	First Stage ⁽³⁾ : Down Second Stage: Over Outlet
	R632A-HCF		FPOL			
	R632A-CFF		1/4 in. FNPT	3/4 in. FNPT		
	R632A-JFF	850,000	FPOL	1/2 in. FNPT	11 in. w.c. / 27 mbar	
	R632A-BCFXA	850,000	1/4 in. FNPT			
	R632A-HCFXA		FPOL			
	R632A-CFFXA	950,000	1/4 in. FNPT	3/4 in. FNPT	11 in. w.c. / 27 mbar	First Stage ⁽³⁾ : Opposite gauge taps Second Stage: Opposite gauge taps
R632A-JFFXA	850,000	FPOL				
Integral 2 psig / 0.14 bar Service	R632E-BCH	850,000	1/4 in. FNPT	1/2 in. FNPT	2 psig / 0.14 bar	First Stage ⁽³⁾ : Down Second Stage: Over Outlet
	R632E-HCH	900,000	FPOL			
	R632E-CFH	850,000	1/4 in. FNPT	3/4 in. FNPT		
	R632E-JFH		FPOL			
2 psig / 0.14 bar Service	R622E-BCH	1,250,000	1/2 in. FNPT	1/2 in. FNPT	2 psig / 0.14 bar	Over Inlet
	R622E-DCH	1,500,000	3/4 in. FNPT	3/4 in. FNPT		
	R652E-DFH	1,400,000				
First Stage	R622H-BGK	2,000,000	1/2 in. FNPT	1/2 in. FNPT	5 psig / 0.35 bar	Over Outlet
	R622H-BGJ	2,100,000			FPOL	
	R622H-HGJ		2,250,000			
	R622H-HGJKA	2,250,000		3/4 in. FNPT	10 psig / 0.69 bar	
	R622H-JGK		2,400,000		3/4 in. FNPT	
	R622H-JGJ	2,400,000				
R622H-DGJ	2,400,000	3/4 in. FNPT				

1. Capacities Based on:
 Second Stage: 10 psig / 0.69 bar inlet pressure and 2 in. w.c. / 5 mbar droop.
 Integral Two-stage: 30 psig / 2.1 bar and 2 in. w.c. / 5 mbar droop.
 Integral Two psig Service: 30 psig / 2.1 bar and 20% droop.
 2 psig / 0.14 bar Service: 10 psig / 0.69 bar inlet pressure and 20% droop.
 First Stage: 30 psig / 2.1 bar inlet pressure and 20% droop.
 2. Straight globe valve body configuration.
 3. Integral First Stage Vent size: 7/16-24 UN thread for 1/4 in. OD copper tube inverted flare fitting.

Installation Location

- The installed regulator should be adequately protected from vehicular traffic and damage from other external sources.
- Install the regulator with the vent pointed vertically down, see Figure 2. If the vent cannot be installed in a vertically down position, the regulator must be installed under a separate protective cover. Installing the regulator with the vent down allows condensation to drain, minimizes the entry of water or other debris from entering the vent and minimizes vent blockage from freezing precipitation.
- Do not install the regulator in a location where there can be excessive water accumulation or ice formation, such as directly beneath a down spout, gutter or roof line of building. Even a protective hood may not provide adequate protection in these instances.
- Install the regulator so that any gas discharge through the vent or vent assembly is over 3 ft / 0.91 m horizontally from any building opening below the level of discharge.
- Install the regulator high enough above ground level at least 18 in. / 45 cm - so that rain splatter cannot freeze in the vent.

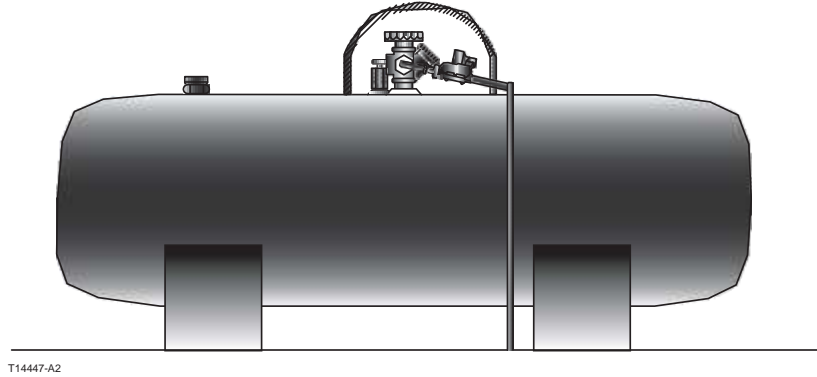

Figure 3. Tank Installation

Regulators Subjected to Heavy Snow Conditions

Some installations, such as in areas with heavy snowfall, may require a hood or enclosure to protect the regulator from snow load and vent freeze over.

Horizontally Installed Regulators

Horizontally mounted regulators, such as found in single cylinder installations and ASME tanks, must be installed beneath a protective cover or under the ASME tank dome, refer to Figure 3. If possible, slope or turn the vent down sufficiently to allow any condensation to drain out of the spring case. Be careful that the slot in the tank dome or protective cover for the regulator's outlet piping does not expose the vent to the elements. The first stage vent on the Types R632A and R632E should be pointed down.

Meter Installations

Type R642 regulators have an angle body that makes it easy to install on to a gas meter instead of piping leading directly into a building.

Meter and Type R642 with Vent over Regulator Inlet:

Install the regulator per instructions given in the previous section "Installation Location".

Meter and Type R642 with Vent over the Regulator Outlet and Installed over the Top of the Meter:

This installation orientation will put the Type R642 regulator vent in a vertical down position, but very close to the top of the gas meter. The regulator vent may become blocked

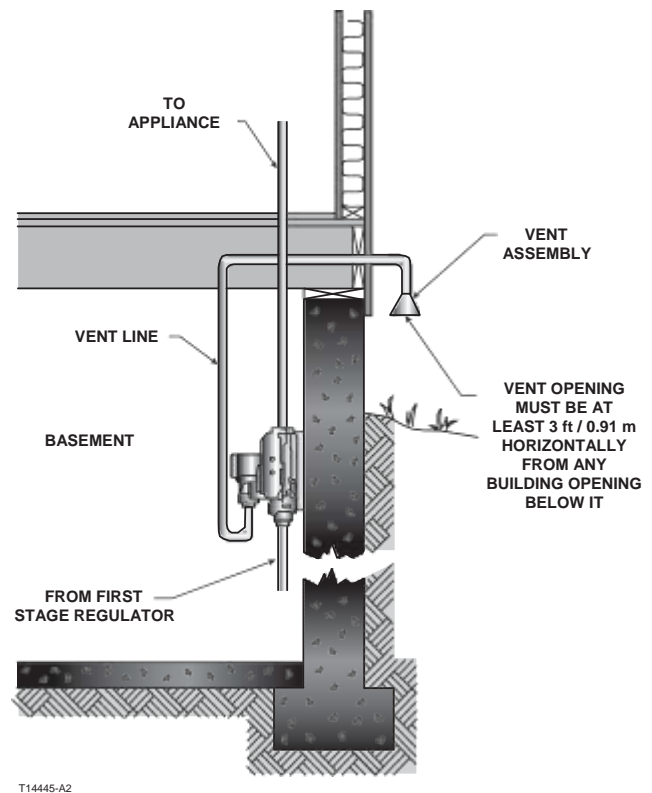

Figure 4. Basement Installation

during a freezing rain storm or heavy snows. Therefore, some type of protective cover should be installed over the regulator and meter or vent piping should be installed so that the vent remains open.

Meter and Type R642 Regulator Installed Indoors:

Pipe the regulator vent per the section "Indoor Installations".

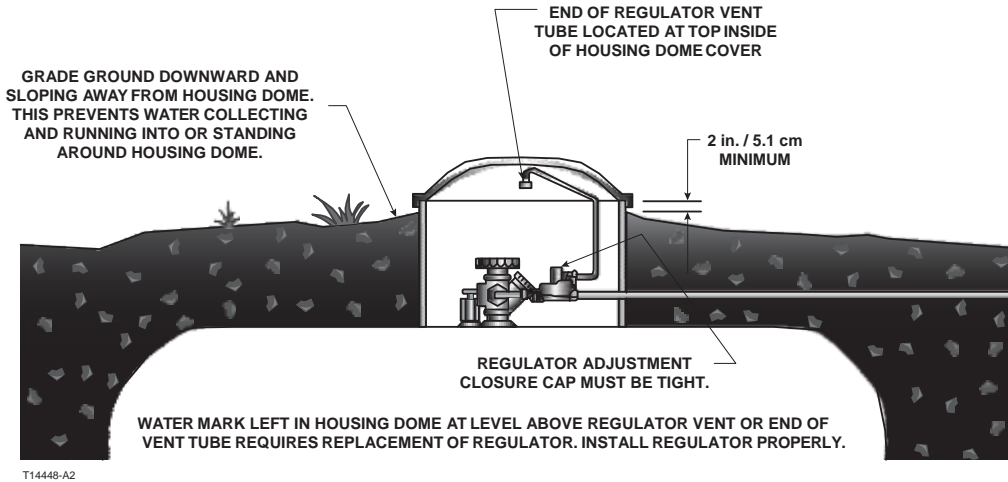

Figure 5. Underground Installation

Indoor Installations

By code, regulators installed indoors have limited inlet pressure and they require a vent line to the outside of the building, see Figure 4. A vent assembly, such as Fisher® Y602 Series, should be used on the end of the vent line. The same installation precautions, previously discussed throughout this manual for the regulator vent, apply to the end of the vent tube assembly. Vent lines must not restrict the gas flow from the regulator's internal relief valve. Vent lines should be at least 3/4 in. NPT pipe or 3/4 in. NPT size PVC Schedule 40 Rigid Conduit, meeting the requirements of Underwriters Laboratories (UL®) 651. To install the vent line, remove the vent screen and apply a good grade of pipe dope to the male threads of the line. Vent lines should be as straight as possible with a minimum number of bends.

Underground Installations

! WARNING

Types R632A and R632E integral regulators require 2 vent tubes, one on the first stage vent and one on the second stage vent, when installed on underground tanks. Failure to use 2 separate vent tubes can result in early regulator failure and/or over pressuring the second stage that could result in fires or personal injury.

Regulators installed in the dome of an underground container require a vent tube to prevent water from entering the regulator spring case, see Figure 5.

Note

Types R632A and R632E integral regulators installed on underground tanks require the use of 2 vent tubes, one for the first stage vent (1/4 in. OD copper tube inverted flare connection: 7/16-24 UN thread) and the other for the second stage vent (3/4 in. NPT) of the regulator.

Remove the vent screens and install vent tubes. The vent tube must be run from the regulator vent to above the maximum water table. The vent tube opening must terminate at the extreme top inside of the dome cover. Make sure the regulator's closing cap is on tightly, and maintain drainage away from the dome at all times.

Outdoor Installations with Underground Vent Lines

When installed per code, the underground vent line must not restrict the gas flow from the regulator's internal relief valve and must remain clear of debris, dry and fully open at all times. Joints in the vent line must be fully sealed to prevent moisture intrusion into the vent line. A vent assembly, such as the Fisher Y602 Series, should be used on the end of the vent line to prevent entry of precipitation, water or other debris. When underground vent lines are used in humid environments, the vent line must be designed to allow for proper drainage of any collected moisture or condensation.

Adjustment

Each regulator is factory set. If it becomes necessary to increase the outlet pressure, remove the closing cap and turn the adjustment screw clockwise. Turn the adjusting screw counterclockwise to decrease the outlet pressure. The first stage portion of the Types R632A and R632E integral regulators is non-adjustable.

The inlet and outlet pressure plug may be removed using a 7/16 in. / 11 mm hexagon wrench. The pressure tap is restricted, so the plug can be removed with pressure on the outlet of the regulator. Install a pressure gauge to determine the regulator's inlet pressure and outlet setting during adjustment, (actual pressure at the second stage regulator may be less due to line loss). After setting, add thread sealant to the 1/8 in. NPT pipe plugs. Reinstall the pipe plugs by threading into the gauge ports finger-tight and then wrench tighten 1-1/2 to 3 turns past finger-tight (approximate maximum torque of 12 ft-lb / 16 N•m). Replace the closing cap. Check the pipe plugs for leakage.

Overpressure Protection

! WARNING

Some type of overpressure protection is needed if actual inlet pressure can exceed the outlet pressure rating. Overpressuring any portion of this equipment above the limits shown in the Specifications section may cause damage to regulator parts, leaks in the regulator or personal injury due to bursting of pressure-containing parts or explosion of accumulated gas.

If any portion of the regulator is exposed to an overpressure condition that exceeds the limits in the Specifications section, it must be inspected for damage that may have occurred.

Large volumes of gas may discharge through the regulator vent during internal relief valve operation, which can, if not controlled, result in fire or explosion from accumulated gas.

The R600 and HSRL Series regulators, except for the first stage of the Types R632A and R632E, contain internal relief valves. The internal relief valve in all units will give overpressure protection against excessive build-up resulting from seat leakage due to worn parts or chips or foreign material on the orifice. The amount of internal relief protection provided varies with the regulator type and the cause for the overpressure relief valve operation. When the internal relief valve opens, gas escapes to the atmosphere through the regulator's vent.

Some type of additional external overpressure protection must be provided if the outlet pressure in an overpressure condition exceeds the inlet pressure rating of the gas system or downstream equipment. Common methods of external overpressure protection include relief valves, monitoring regulators, shutoff devices and series regulation.

Maintenance

! WARNING

To avoid personal injury or equipment damage, do not attempt any maintenance or disassembly without first isolating the regulator from system pressure and relieving all internal pressure.

Regulators that have been disassembled for repair must be tested for proper operation before being returned to service. Only parts manufactured by Fisher® should be used for repairing Fisher regulators. Relight pilot lights according to normal startup procedures.

Due to normal wear or damage that may occur from external sources, these regulators must be inspected and maintained periodically. The frequency of inspection and replacement of the regulators depends upon the severity of service conditions or the requirements of local, state and federal regulations. Even under ideal conditions, these regulators should be replaced after 20 years from date of manufacture or sooner should inspection reveal the need.

Failure to replace a regulator that has had water inside due to flooding, water table level or weather events or has corrosion present could result in personal injury or property damage.

Visually inspect the regulator each time a gas delivery is made for:

- Improper installation, vent not pointed vertically down or under a cover; no vent tube on underground systems
- Plugged or frozen vent
- Wrong regulator or no regulator in the system
- Internal or external corrosion, including paint chipping or flaking
- Flooded Regulator; water in spring case; regulator submersed on underground tanks
- Regulator age
- Any other condition that could cause the uncontrolled escape of gas

Vent Opening

Make sure the regulator vent, vent assembly or vent tube does not become plugged by mud, insects, ice, snow, paint, etc. The vent screen aids in keeping the vent from becoming plugged and the screen should be clean and properly installed. Make sure any irrigation system operated near a regulator or vent line does not spray water into the vent opening of the regulator or vent assembly.

Water Inside Regulators from Floods, Weather or Water Table on Underground Systems

Replace any regulator that had water in their spring case, has been flooded, has been submersed below the water table of an underground tank or shows evidence of external or internal corrosion. Checking for internal corrosion can be done by removing the closing cap and with the aid of a flashlight observing the condition of the relief valve spring, main spring and internal spring barrel area. A more detailed examination will require shutting down of the gas system and the complete removal of the adjusting screw. Closely examine regulators installed with their vent horizontal for signs of corrosion. Correct any improper installations.

Regulator Replacement

Older regulators are more likely to catastrophically fail because of worn or corroded parts. Replace R600 and HSRL Series regulators over 20 years of age. Other service or environmental conditions may dictate replacement of the

regulator before it becomes 20 years old. Regulators that are installed in corrosive environments including but not limited to the following conditions should be inspected annually for visual indication of external or internal corrosion and paint chipping or flaking. Regulators in these applications may require replacement sooner and must be replaced if corrosion is evident:

- Regulators that are installed in areas subject to sea salt (coastal) atmosphere
- Regulators that are installed on underground systems
- Regulators installed with underground vent piping
- Regulators that are used in installations where the gas system is only operated and pressurized intermittently

Refer to Fisher® Bulletin LP-32 for additional information.

Regulator Repair

Regulators that have been disassembled for repair must be tested for proper operation before being returned to service. Only parts manufactured by Fisher should be used to repair Fisher regulators. Be sure to give the complete type number of the regulator when corresponding with the factory.

The type number, orifice size and spring range are on a label attached to the spring barrel. The date of manufacture is stamped on the regulator. Always provide this information in any correspondence with your Fisher Distributor regarding replacement parts or technical assistance. If construction changes are made in the field, be sure that the regulator marking is also changed to reflect the most recent construction.