



บริษัท เอดีดี เฟอร์เนส จำกัด

**ADD FURNACE CO.,LTD.**

44 ซอยบรมราชชนนี 70 ถนนบรมราชชนนี แขวงศาลาธรรมสพน์ เขตทวีวัฒนา กรุงเทพฯ 10170

โทร: 02-888-3472 โทร: ออกแบบ:08-08-170-170 แฟกซ์: 02-888-3258

<https://www.add-furnace.com> E-mail: [sales@add-furnace.com](mailto:sales@add-furnace.com)

Bulletin 71.1  
D103152X012

67D Series

June 2020

## 67D Series Pressure Reducing Regulators



P1183\_1

TYPE 67D OR 67DR REGULATOR



P1182\_1

TYPE 67DF OR 67DFR FILTERED REGULATOR

Figure 1. 67D Series Pressure Reducing Regulators

- **Optional Smart Bleed™ Construction**
- **Optional Stainless Steel Construction**
- **Compact and Light Weight**
- **No Air Loss**
- **Easy Maintenance**
- **Optional Integral Filter**
- **Optional Internal Relief Valve**
- **Rugged Construction**



## 67D Series

### Specifications

The Specifications section gives some general specifications for the 67D Series regulator. A label on the spring case gives the control spring range for a given regulator as it comes from the factory.

#### Available Configurations

- Type 67D:** Direct-operated regulator with aluminum body and without internal relief
  - Type 67DR:** Aluminum body with internal relief
  - Type 67DS:** Stainless steel body without internal relief
  - Type 67DSR:** Stainless steel body with internal relief
  - Type 67DF:** Aluminum body with filter and without internal relief
  - Type 67DFR:** Aluminum body with filter and internal relief
  - Type 67DFS:** Stainless steel body with filter and without internal relief
  - Type 67DFSR:** Stainless steel body with filter and internal relief
- See also Table 1

#### Body Size, Inlet and Outlet Connection Style

1/2 NPT

#### Construction Materials

See Table 3

#### Maximum Inlet Pressure (Body Rating)<sup>(1)</sup>

All filtered models: 250 psig / 17.2 bar

All unfiltered models: 400 psig / 27.6 bar

#### Outlet Pressure Ranges

See Table 2

#### Maximum Emergency Outlet Pressure<sup>(1)</sup>

150 psi / 10.3 bar over outlet pressure setting up to a maximum of 250 psi / 17.2 bar

#### Flow Capacities

See Table 4 and Capacity Information section

#### Wide-Open Flow Coefficients

Main Valve:  $C_g$ : 45.24;  $C_v$ : 1.33;  $C_f$ : 35.02;

Internal Relief Valve:  $C_g$ : 1.45;  $C_v$ : 0.045;  $C_f$ :

#### 32.8 IEC Sizing Coefficients

$X_t$ : 0.75

#### Types 67DR, 67DSR, 67DFR and 67DFSR Internal Relief Performance

Low capacity for minor seat leakage only, other overpressure protection must be provided if inlet pressure can exceed the maximum pressure rating of downstream equipment or exceeds maximum outlet pressure rating of the regulator.

#### Approximate Weights

- Types 67D and 67DR: 1.2 lb / 0.5 kg
- Types 67DF and 67DFR: 2.0 lbs / 0.9 kg
- Types 67DS and 67DSR: 2.8 lbs / 1.2 kg
- Types 67DFS and 67DFSR: 4.6 lbs / 2.1 kg

#### Smart Bleed™ Check Valve Setpoint

6 psi / 0.41 bar differential

#### Pressure Registration

Internal

#### Spring Case Vent Location

Aligned with inlet standard, other positions optional

#### Drain Valve Location

Aligned in the center of the dripwell

#### Temperature Capabilities<sup>(1)</sup>

##### With Nitrile (NBR)

Standard Bolting: -20 to 180°F / -29 to 82°C

Stainless Steel Bolting: -40 to 180°F / -40 to 82°C

##### With Fluorocarbon (FKM)<sup>(5)</sup>:

Polyethylene Filter<sup>(4)</sup> (standard):

0 to 180°F / -18 to 82°C

Polyvinylidene (PVDF), Stainless Steel or Glass

Filter (Optional): 0 to 300°F / -18 to 149°C

##### With Silicone (VMQ)<sup>(2)</sup> diaphragm, Low Temperature

Nitrile (NBR) O-rings and Low Temperature bolting:

-60 to 180°F / -51 to 82°C

With Gauges: -40 to 180°F / -40 to 82°C

With Automatic drain: 40 to 175°F / 4 to 79°C

#### Types 67DF, 67DFR, 67DFS and 67DFSR Filter Capabilities Micron Rating:

Polyethylene Filter<sup>(4)</sup> (standard): 5 microns

Glass Fiber Filter (Optional): 5 microns

PVDF Filter (Optional): 40 microns

Stainless Steel Filter (Optional): 40 microns

1. The pressure/temperature limits in this Bulletin and any applicable standard or code limitation should not be exceeded.

2. Silicone (VMQ) is not compatible with hydrocarbon gas.

3. Product complies with the material requirements of NACE International MR0175 or MR0103. Environmental limits may apply.

4. Do not use in high aromatic hydrocarbon service.

5. Consult factory for applications where the Smart Bleed unit will be at process temperatures above 180°F / 82°C for an extended period.



## Specifications (continued)

### Options

#### All Types

- Handwheel adjusting screw
- NACE International MR0175 or MR0103<sup>(3)</sup> construction
- Panel mount (includes spring case with 1/4 NPT vent, handwheel and panel mounting nut)
- Closing cap (available on spring case with 1/4 NPT vent)
- Fluorocarbon (FKM) elastomers for high temperatures and/or corrosive chemicals
- Silicone (VMQ) elastomers for cold temperatures

#### All Types (continued)

- Fixed Bleed Restriction
- Triple scale outlet pressure gauge (brass or stainless steel)
- Stainless steel stem and valve plug
- Pipe plug in second outlet

#### Types 67DFR and 67DFSR only

- Smart Bleed internal check valve<sup>(1)</sup>

#### Types 67DF, 67DFR, 67DFS and 67DFSR

- Stainless steel drain valve

## Introduction

The 67D Series regulators are typically used to deliver constant reduced pressure of gaseous fluids to pilot-operated controllers and other pneumatic instrumentation. As shown in the Available Configurations table, an assortment of regulators is available to meet diverse flow requirements.

## Features

- **Compact**—The 67D Series regulators are engineered for outstanding performance in a compact, lightweight package.
- **Pilot Supply Regulator**—Improves the accuracy of two-path control regulators by reducing inlet sensitivity caused by fluctuating inlet pressures.
- **Pressure Loading Regulator**—Provides accuracy and improved performance in dirty steam service by eliminating the need for a pilot regulator.
- **Sour Gas Service Capability**—NACE International MR0175 and MR0103 compliant construction available.
- **Optional Stainless Steel Construction**—The Types 67DS, 67DSR, 67DFS and 67DFSR provide high resistance to corrosion, which is especially beneficial for offshore applications.

- **Full Usable Capacity**—Fisher™ regulators are laboratory tested. 100% of the published capacities can be used with confidence.
- **Internal Relief**—The Types 67DR, 67DSR, 67DFR and 67DFSR have an internal relief valve with a soft seat for reliable shutoff with no discernible leakage. These regulators are recommended for conserving plant air.
- **Smart Bleed™**—Opens to exhaust downstream pressure when inlet pressure drops below outlet pressure. Recommended for dead-end service, fail-safe actuators and no bleed applications.
- **Integral Filter**—The Types 67DF, 67DFR, 67DFS and 67DFSR have an integral filter ensuring clean downstream air supply.
- **Ease of Maintenance**—No special tools are required to perform maintenance and all maintenance can be performed with the regulator in the line. Filter elements are easily replaced.
- **Rugged Construction**—The 67D Series regulators are engineered for longer service life with minimal maintenance requirements.
- **Dual Second Outlets**—Body side outlets for pressure gauge or other uses.
- **Corrosion Resistant Fasteners**—Bolting and adjusting screw are double zinc-chromated for enhanced corrosion resistance. Optional stainless steel bolting and adjusting screw are also available.

1. The Smart Bleed internal check valve is bubble tight at temperatures down to -40°F / -40°C. Leakage from P<sub>1</sub> to P<sub>2</sub> is possible at temperatures below -40°F / -40°C.



บริษัท เอดีดี เฟอร์เนจ จำกัด

**ADD FURNACE CO.,LTD.**

44 ซอยบรมราชชนนี 70 ถนนบรมราชชนนี แขวงศาลาธรรมสพน์ เขตทวีวัฒนา กรุงเทพฯ 10170

โทร: 02-888-3472 โทร: ออกแบบ:08-08-170-170 แฟกซ์: 02-888-3258

https://www.add-furnace.com E-mail: [sales@add-furnace.com](mailto:sales@add-furnace.com)

## 67D Series

**Table 1. Available Configurations**

TYPE	CONSTRUCTION FEATURE		OPTIONAL FEATURE			BODY MATERIAL	
	With Internal Relief	With Filter	Smart Bleed™ Internal Check Valve Airset	Drain Valve	External Fixed Bleed	Aluminum	Stainless Steel
67D						X	
67DR	X				X	X	
67DS							X
67DSR	X				X		X
67DF		X		X		X	
67DFR	X	X	X	X	X	X	
67DFS		X		X			X
67DFSR	X	X	X	X	X		X

**Table 2. Outlet Pressure Ranges and Control Spring Data**

TYPE	OUTLET PRESSURE RANGE		CONTROL SPRING DATA						
			Part Number	Material	Color Code	Wire Diameter		Free Length	
	psig	bar				In.	mm	In.	mm
67D, 67DR, 67DF and 67DFR	0 to 20	0 to 1.4	GE07809T012 T14059T0012 T14058T0012 T14060T0012	Music Wire	Green stripe	0.135	3.43	1.43	36.2
	0 to 35	0 to 2.4			Silver	0.156	3.96	1.43	36.2
	0 to 60	0 to 4.1			Blue stripe	0.170	4.32	1.43	36.2
	0 to 125	0 to 8.6			Red stripe	0.207	5.26	1.43	36.2
67DS, 67DSR, 67DFS and 67DFSR	0 to 35	0 to 2.4	T14113T0012 T14114T0012 T14115T0012	Inconel®	Silver stripe	0.156	3.96	1.43	36.2
	0 to 60	0 to 4.1			Blue	0.172	4.37	1.43	36.2
	0 to 125	0 to 8.6			Red	0.207	5.26	1.43	36.2
	0 to 150	0 to 10.3			Black	0.250	6.35	1.77	44.9

**Table 3. Construction Materials**

MATERIAL	TYPE			
	67D and 67DR	67DF and 67DFR	67DS and 67DSR	67DFS and 67DFSR
<b>BODY AND SPRING CASE</b>	Aluminum (ASTM B85/Alloy 380)		CF8M/CF3M Stainless steel	
<b>SPRING RETAINER</b>	Aluminum	Zinc-plated steel	316L Stainless steel	
<b>UPPER SPRING SEAT</b>	Zinc-plated steel		316 Stainless steel	
<b>DIAPHRAGM PLATE</b>	Chromate conversion coated Aluminum			
<b>CONTROL SPRING</b>	Plated steel or Inconel® (NACE)		Inconel®	
<b>VALVE STEM</b>	Brass, Aluminum or Stainless steel		316L Stainless steel	
<b>VALVE PLUG</b>				
<b>VALVE SPRING</b>	Stainless steel or Inconel® (NACE)			
<b>DIAPHRAGM AND O-RINGS</b>	Nitrile (NBR), Fluorocarbon (FKM), Low Temp Nitrile (NBR) or Silicone (VMQ) <sup>(1)</sup>			
<b>SOFT SEAT AND GASKETS</b>	Nitrile (NBR) or Fluorocarbon (FKM)			
<b>BOLTING AND ADJUSTING SCREW</b>	Zinc-plated steel or Stainless steel			
<b>HANDWHEEL</b>	Zinc-plated steel		Zinc-plated steel or Stainless steel	
<b>FILTER RETAINER</b>	----	316 Stainless steel	----	316 Stainless steel
<b>FILTER ELEMENT</b>	----	Plastic, Glass fiber or Stainless steel	----	Plastic, Glass fiber or Stainless steel
<b>DRAIN VALVE</b>	----	Brass or 18-8 Stainless steel	----	316 Stainless steel or 18-8 Stainless steel
<b>DRIPWELL</b>	----	Aluminum (ASTM B85/Alloy 380)	----	CF8M/CF3M Stainless steel

1. Silicone (VMQ) diaphragm is only available with internal relief (Types 67DR, 67DSR, 67DFR and 67DFSR).

Inconel® is a mark owned by Special Metals Corporation.



## 67D Series

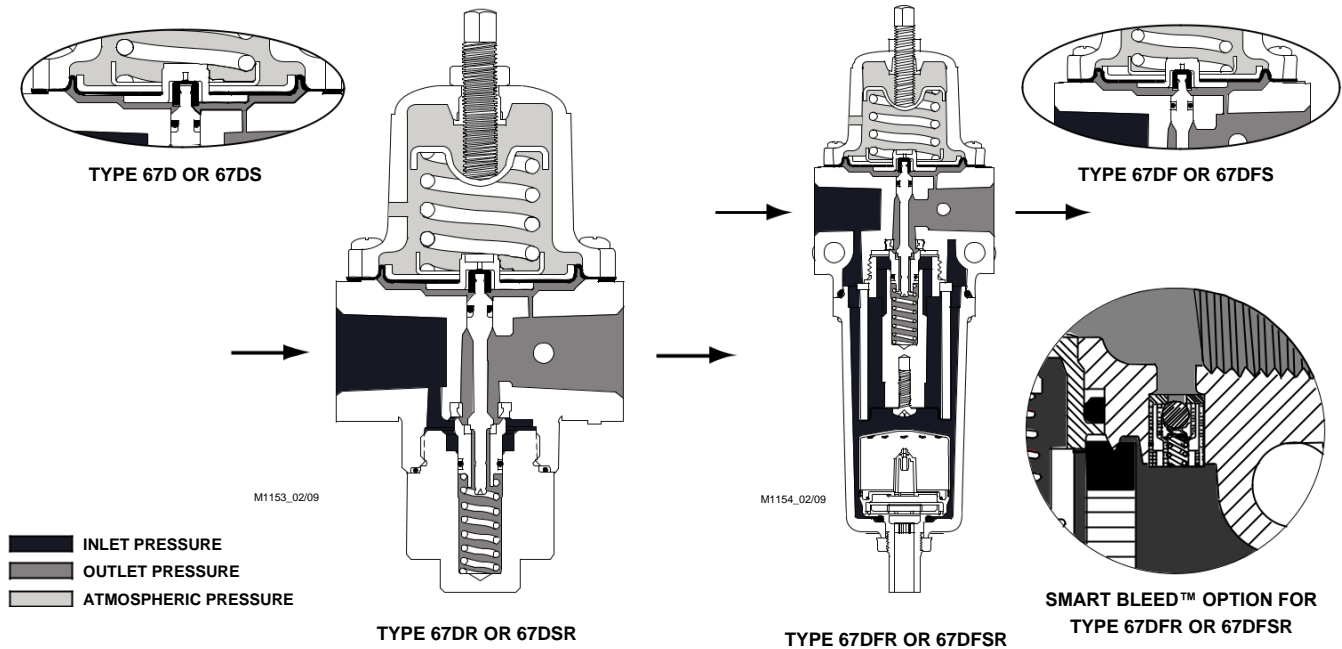

Figure 2. 67D Series Operational Schematics

### Principle of Operation (Figure 2)

Downstream pressure is registered internally on the lower side of the diaphragm. When the downstream pressure is at or above the set pressure, the valve plug is held against the orifice and there is no flow through the regulator. When demand increases, downstream pressure drops slightly allowing the spring to extend, moving the stem down and the valve plug away from the orifice. This allows flow through the regulator.

### Internal Relief (Types 67DR, 67DSR, 67DFR and 67DFSR)

If for some reason, outside of normal operating conditions, the downstream pressure exceeds the setpoint of the regulator, the force created by the downstream pressure will lift the diaphragm until the diaphragm is lifted off the relief seat. This allows flow through the token relief. The relief valve on the Type 67DR, 67DSR, 67DFR or 67DFSR is an elastomer plug that prevents leakage of air from the downstream to atmosphere during normal operation, thereby conserving plant air.

### Smart Bleed Airset

Recommended for fail-safe actuators, no bleed applications and dead-end service.

In some cases, it is desired to exhaust downstream pressure if inlet pressure is lost or drops below the setpoint of the regulator. For example, if the regulator is installed on

equipment that at times has no flow demand but is expected to backflow on loss of inlet pressure. The Types 67DFR and 67DFSR can be ordered with the Smart Bleed option which includes an integrated soft seat check valve. During operation, if inlet pressure is lost or decreases below the setpoint of the regulator, the downstream pressure will back flow upstream through the regulator and check valve. This option eliminates the need for a fixed bleed downstream of the regulator, thereby conserving plant air. In addition, the soft seat feature of the check valve eliminates leakage while the airset is in the lock-up position, preventing pressure build-up that could trip safety loop functions on valves.

### Installation

The 67D Series regulators may be installed in any position but vertical orientation is recommended for models with draining features. Spring case vents must be protected against the entrance of rain, snow, debris or any other foreign material that might plug the vent openings. The inlet connection is marked "In" and the main outlet connection is marked "Out". If a pressure gauge is not installed in one of the two secondary outlet connections, plug the unused connections. See Figures 4 and 5 for dimensions.

Emerson Process Management Regulator Technologies, Inc. provides an instruction manual with every regulator shipped. Refer to this for complete installation, operation and maintenance instructions. Included is a complete listing of individual parts and recommended spare parts.



## 67D Series

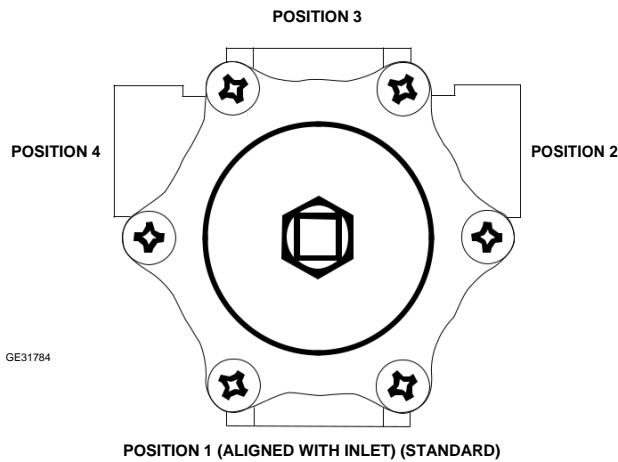

Figure 3. 67D Series Vent Positions

### Overpressure Protection

The 67D Series regulators have maximum outlet pressure ratings that are lower than their maximum inlet pressure ratings. A pressure-relieving or pressure-limiting device is needed if inlet pressure can exceed the maximum outlet pressure rating.

Types 67DR, 67DSR, 67DFR and 67DFSR regulators have a low capacity internal relief valve for minor seat leakage only. Other overpressure protection must be provided if the maximum inlet pressure can exceed the maximum pressure rating of the downstream equipment or exceeds maximum outlet pressure rating of the Type 67DR, 67DSR, 67DFR or 67DFSR regulator.

Overpressuring any portion of a regulator or associated equipment may cause leakage, parts damage or personal injury due to bursting of pressure-containing parts or explosion of accumulated gas. Regulator operation within ratings does not preclude the possibility of damage from external sources or from debris in the pipeline. A regulator should be inspected for damage periodically and after any overpressure condition.

Refer to the Capacity Information section and the Wide-Open Flow Coefficients for Relief Valve Sizing in the Specifications section on page 3 to determine the required relief valve capacity.

### Capacity Information

Table 4 shows the air regulating capacities of the 67D Series regulators at selected inlet pressures and outlet pressure settings. Flows are shown in SCFH (at 60°F and 14.7 psia) and in Nm<sup>3</sup>/h (at 0°C and 1.01325 bar) of air.

### Note

The 67D Series regulators may be sized for 100% flow using capacities as shown in Table 4. It is not necessary to reduce published capacities.

To determine the equivalent capacities for other gases, multiply the table capacity by the following appropriate conversion factor: 1.29 for 0.6 specific gravity natural gas, 0.810 for propane, 0.707 for butane or 1.018 for nitrogen. For gases of other specific gravities, divide the table capacities by the square root of the appropriate specific gravity. To find wide-open flow capacities for relief sizing at any inlet pressure, perform one of the following procedures. Then, if necessary, convert using the factors provided above.

**For critical pressure drops** (absolute outlet pressure equal to or less than one-half of absolute inlet pressure), use the following formula:

$$Q = (P_1)(C_g)$$

**For pressure drops lower than critical** (absolute outlet pressure greater than one-half of absolute inlet pressure), use the following formula:

$$Q = \sqrt{\frac{520}{GT}} C_g P_1 \sin \left( \frac{3417}{C_1} \sqrt{\frac{\Delta P}{P_1}} \right) \text{ DEG}$$

where,

- Q = gas flow rate, SCFH
- $P_1$  = absolute inlet pressure, psia ( $P_1$  gauge + 14.7)
- $C_g$  = gas sizing coefficient
- G = specific gravity of the gas
- $T_1$  = absolute temperature of gas at inlet, °Rankine
- $C_1$  = flow coefficient ( $C_g \div C_v$ )
- $\Delta P$  = pressure drop across the regulator, psi

Then, if capacity is desired in normal cubic meters per hour (at 0°C and 1.01325 bar), multiply SCFH by 0.0268.

### NACE Universal Compliance

Optional materials are available for applications handling sour gases. These constructions comply with the recommendations of NACE International sour service standards.

The manufacturing processes and materials used by Regulator Technologies assure that all products specified for sour gas service comply with the chemical, physical and metallurgical requirements of NACE MR0175 and/or NACE MR0103. Customers have the responsibility to specify correct materials. Environmental limitations may apply and shall be determined by the user.



67D Series

Table 4. 67D Series Flow Capacities

OUTLET PRESSURE RANGE, SPRING PART NUMBER AND COLOR CODE	OUTLET PRESSURE		INLET PRESSURE		CAPACITIES IN SCFH / Nm <sup>3</sup> /h OF AIR												
	psig	bar	psig	bar	Types 67D, 67DR, 67DS and 67DSR						Types 67DF, 67DFR, 67DFS and 67DFS R						
					5% Droop		10% Droop		20% Droop		5% Droop		10% Droop		20% Droop		
					SCFH	Nm <sup>3</sup> /h	SCFH	Nm <sup>3</sup> /h	SCFH	Nm <sup>3</sup> /h	SCFH	Nm <sup>3</sup> /h	SCFH	Nm <sup>3</sup> /h	SCFH	Nm <sup>3</sup> /h	
0 to 20 psig / 0 to 1.4 bar GE07809T012 (Green Stripe) 10C1729X012 (Green)	5	0.34	25	1.7	320	8.6	530	14.2	950	25.5	320	8.6	400	10.7	600	16.1	
			50	3.4	740	19.8	1100	29.5	2200	59.0	400	10.7	540	14.5	1100	29.5	
			75	5.2	1000	26.8	2700	72.4	3200	85.8	460	12.3	850	22.8	2600	69.7	
			100	6.9	750	20.1	3600	96.5	4100	110	590	15.8	2800	75.0	2900	77.7	
			150	10.3	850	22.8	3200	85.8	6100	163	780	20.9	1700	45.6	3900	105	
			200	13.8	240	6.4	810	21.7	6300	169	940	25.2	1700	45.6	2200	59.0	
			250	17.2	290	7.8	460	12.3	6300	169	1000	26.8	1800	48.2	2200	59.0	
			400 <sup>(1)</sup>	27.6	370	9.9	590	15.8	2700	72.4	----	----	----	----	----	----	----
	10	0.69	25	1.7	450	12.1	790	21.2	1100	29.5	390	10.5	570	15.3	830	22.2	
			50	3.4	1100	29.5	1900	50.9	2700	72.4	600	16.1	750	20.1	1700	45.6	
			75	5.2	2600	69.7	3200	85.8	3900	105	870	23.3	2100	56.3	3100	83.1	
			100	6.9	3900	104	4400	118	5100	137	1100	29.5	3300	88.4	3900	105	
			150	10.3	3400	91.1	6600	177	7400	198	2200	59.0	3200	85.8	4800	129	
			200	13.8	1200	32.2	7800	209	7800	209	1900	50.9	2300	61.6	4900	131	
			250	17.2	850	22.8	8000	214	8000	214	2000	53.6	2400	64.3	3300	88.4	
			400 <sup>(1)</sup>	27.6	470	12.6	3400	91.1	4700	126	----	----	----	----	----	----	----
	20	1.4	50	3.4	1500	40.2	2100	56.3	2600	69.7	870	23.3	1500	40.2	2100	56.3	
			75	5.2	2600	69.7	3500	93.8	3800	102	1600	42.9	2600	69.7	3400	91.1	
			100	6.9	4500	121	4900	131	5100	137	3600	96.5	4300	115	4600	123	
			150	10.3	6700	180	7200	193	7600	204	4000	107	6600	177	6600	177	
			200	13.8	9000	241	9400	252	10,000	268	3300	88.4	4700	126	6900	185	
			250	17.2	11,200	300	11,200	300	11,200	300	2900	77.7	5100	137	7100	190	
			400 <sup>(1)</sup>	27.6	5500	147	6100	163	9100	244	----	----	----	----	----	----	----
			0 to 35 psig / 1 to 2.4 bar T14059T0012 (Silver) T14113T0012 (Silver Stripe)	15	1.0	25	1.7	480	12.9	760	20.4	1000	26.8	360	9.7	520	14.0
50	3.4	860				23.0	1500	40.2	2200	59.0	720	19.3	1300	34.8	2100	56.3	
75	5.2	1200				32.2	2700	72.4	3700	99.2	870	23.3	2100	56.3	3500	93.8	
100	6.9	2000				53.6	3900	104	4800	129	1100	29.5	3700	99.2	4400	118	
150	10.3	5000				134	5900	158	7200	193	3400	91.1	5700	153	6400	172	
200	13.8	1000				26.8	7600	204	8800	236	2600	69.7	4100	110	5900	158	
250	17.2	500				13.4	8900	239	9200	247	2700	72.4	3300	88.4	6000	161	
400 <sup>(1)</sup>	27.6	820				22.0	6400	172	7400	198	----	----	----	----	----	----	----
20	1.4	25		1.7	370	9.9	570	15.3	810	21.7	420	11.3	570	15.3	940	25.2	
		50		3.4	770	20.6	1200	32.2	1900	50.9	880	23.6	1500	40.2	2300	61.6	
		75		5.2	1100	29.5	2600	69.7	3800	102	1100	29.5	2400	64.3	3900	105	
		100		6.9	1800	48.2	4500	121	5200	139	1800	48.2	3800	102	4800	129	
		150		10.3	6200	166	7000	188	7500	201	3900	104	6600	177	7000	188	
		200		13.8	2900	77.7	7500	201	7800	209	5600	150	8700	233	8700	233	
		250		17.2	4900	131	11,000	295	11,000	295	4400	118	8800	236	8800	236	
		400 <sup>(1)</sup>		27.6	830	22.2	8300	222	8300	222	----	----	----	----	----	----	----
35	2.4	50		3.4	1000	26.8	1700	45.6	2200	59.0	840	22.5	1300	34.8	2000	53.6	
		75		5.2	2000	53.6	3200	85.8	3700	99.2	1500	40.2	2500	67.0	3300	88.4	
		100		6.9	2900	77.7	4500	121	5100	137	2000	53.6	3900	104	4700	126	
		150		10.3	6700	180	7100	190	7600	204	6300	169	6800	182	7000	188	
		200		13.8	9000	241	9500	255	9900	265	8800	236	9000	241	9000	241	
		250		17.2	11,100	297	11,900	319	12,500	335	6000	161	10,000	268	10,000	268	
		400 <sup>(1)</sup>		27.6	7600	204	9300	249	12,800	343	----	----	----	----	----	----	----

1. Inlet pressures above 250 psig / 17.2 bar with a maximum of 400 psig / 27.6 bar are only available on unfiltered models (Types 67D, 67DR, 67DS and 67DSR).

- continued -



## 67D Series

Table 4. 67D Series Flow Capacities (continued)

OUTLET PRESSURE RANGE, SPRING PART NUMBER AND COLOR CODE	OUTLET PRESSURE		INLET PRESSURE		CAPACITIES IN SCFH / Nm <sup>3</sup> /h OF AIR											
	psig	bar	psig	bar	Types 67D, 67DR, 67DS and 67DSR						Types 67DF, 67DFR, 67DFS and 67DFS R					
					5% Droop		10% Droop		20% Droop		5% Droop		10% Droop		20% Droop	
					SCFH	Nm <sup>3</sup> /h	SCFH	Nm <sup>3</sup> /h	SCFH	Nm <sup>3</sup> /h	SCFH	Nm <sup>3</sup> /h	SCFH	Nm <sup>3</sup> /h	SCFH	Nm <sup>3</sup> /h
0 to 60 psig / 0 to 4.1 bar T14058T0012 (Blue Stripe) T14114T0012 (Blue)	35	2.4	50	3.4	850	22.8	1400	37.5	2100	53.6	690	18.5	1100	29.5	1800	48.2
			75	5.2	1400	37.5	2500	67.0	3600	96.5	1000	26.8	1900	50.9	2900	77.7
			100	6.9	1900	50.9	4100	110	5100	137	1600	42.9	2700	72.4	4300	115
			150	10.3	6600	177	7100	190	7600	204	3100	83.1	5600	150	6600	177
			200	13.8	9200	247	9600	257	10,200	273	7200	193	8400	225	8900	239
			250	17.2	11,200	300	11,500	308	11,500	308	9500	255	9500	255	9500	255
	400 <sup>(1)</sup>	27.6	1100	29.5	11,900	319	11,900	319	----	----	----	----	----	----	----	
	60	4.1	75	5.2	1200	32.2	2200	59.0	3000	80.4	920	24.7	1600	42.9	2600	69.7
			100	6.9	2100	56.3	3600	96.5	4600	123	1500	40.2	2500	67.0	4000	107
			150	10.3	4300	115	6900	185	7600	204	2600	69.7	5200	139	6600	177
			200	13.8	9200	247	9700	260	10,200	273	4300	115	8300	222	8800	236
			250	17.2	11,900	319	12,400	332	12,800	343	9500	255	10,600	284	11,100	297
400 <sup>(1)</sup>			27.6	4000	107	18,000	482	18,000	482	----	----	----	----	----	----	----
0 to 125 psig / 0 to 8.6 bar T14060T0012 (Red Stripe) T14115T0012 (Red)	60	4.1	75	5.2	690	18.5	1200	32.2	2000	53.6	670	18.0	1100	29.5	2000	53.6
			100	6.9	1000	26.8	1900	50.9	3000	80.4	1000	26.8	1800	48.2	2900	77.7
			135	9.3	1500	40.2	3000	80.4	4600	123	1300	34.8	2500	67.0	4300	115
			150	10.3	1700	45.6	3500	93.8	5300	142	1400	37.5	2800	75.0	5200	139
			200	13.8	2500	67.0	6000	161	7700	206	1800	48.2	4100	110	7600	204
			250	17.2	5600	150	8100	217	9300	249	2400	64.3	6600	177	10,200	273
	400 <sup>(1)</sup>	27.6	3500	93.8	17,900	480	17,900	480	----	----	----	----	----	----	----	
	80	5.5	100	6.9	1000	26.8	1700	45.6	2900	77.7	960	25.7	1700	45.6	3000	80.4
			135	9.3	1600	42.9	3000	80.4	4600	123	1500	40.2	2800	75.0	4600	123
			150	10.3	1900	50.9	3700	99.2	5400	145	1700	45.6	3100	83.1	5300	142
			200	13.8	2900	77.7	6000	161	7700	206	2200	59.0	4800	129	8000	214
			250	17.2	4200	113	10,200	273	12,200	327	2900	77.7	7100	190	10,600	284
			400 <sup>(1)</sup>	27.6	3700	99.2	19,900	533	10,400	279	----	----	----	----	----	----
	125	8.6	135	9.3	1500	40.2	2500	67.0	3500	93.8	1600	42.9	2700	72.4	4400	118
			150	10.3	2100	56.3	3200	85.8	4300	115	1800	48.2	3200	85.8	5200	139
			200	13.8	3800	102	5600	150	6700	180	2900	77.7	5200	139	8000	214
			250	17.2	5800	155	7800	209	9000	241	4100	110	7800	209	10,400	279
			400 <sup>(1)</sup>	27.6	6800	182	19,400	520	20,900	560	----	----	----	----	----	----
----			----	----	----	----	----	----	----	----	----	----	----	----	----	----
0 to 150 psig / 0 to 10.3 bar <sup>(2)</sup> 10C1730X012 (Black)	110	7.6	150	10.3	1900	50.9	3300	88.4	5500	147	2000	53.6	3400	91.1	5600	150
			200	13.8	2700	72.4	4800	129	8300	222	2600	69.7	4800	129	8000	214
			250	17.2	3400	91.1	6200	166	10,500	281	3400	91.1	6000	161	10,400	279
	400 <sup>(1)</sup>	27.6	4200	113	11,300	303	19,100	512	----	----	----	----	----	----	----	
	135	9.3	150	10.3	1800	48.2	3300	88.4	5600	150	1800	48.2	3200	85.8	5500	147
			200	13.8	3000	80.4	5400	145	8300	222	2800	75.0	5100	137	8200	220
			250	17.2	3900	105	6700	180	10,700	287	3700	99.2	6600	177	11,000	295
	400 <sup>(1)</sup>	27.6	6400	172	13,300	356	19,300	517	----	----	----	----	----	----	----	
	150	10.3	200	13.8	2900	77.7	5200	139	8300	222	2900	77.7	5200	139	8200	220
250			17.2	4000	107	7400	198	11,000	295	4100	110	7300	196	11,000	295	
400 <sup>(1)</sup>			27.6	6400	172	13,900	373	19,700	528	----	----	----	----	----	----	----

1. Inlet pressures above 250 psig / 17.2 bar with a maximum of 400 psig / 27.6 bar are only available on unfiltered models (Types 67D, 67DR, 67DS and 67DSR).  
 2. Available for Types 67DS, 67DSR, 67DFS and 67DFS R only.





# 67D Series

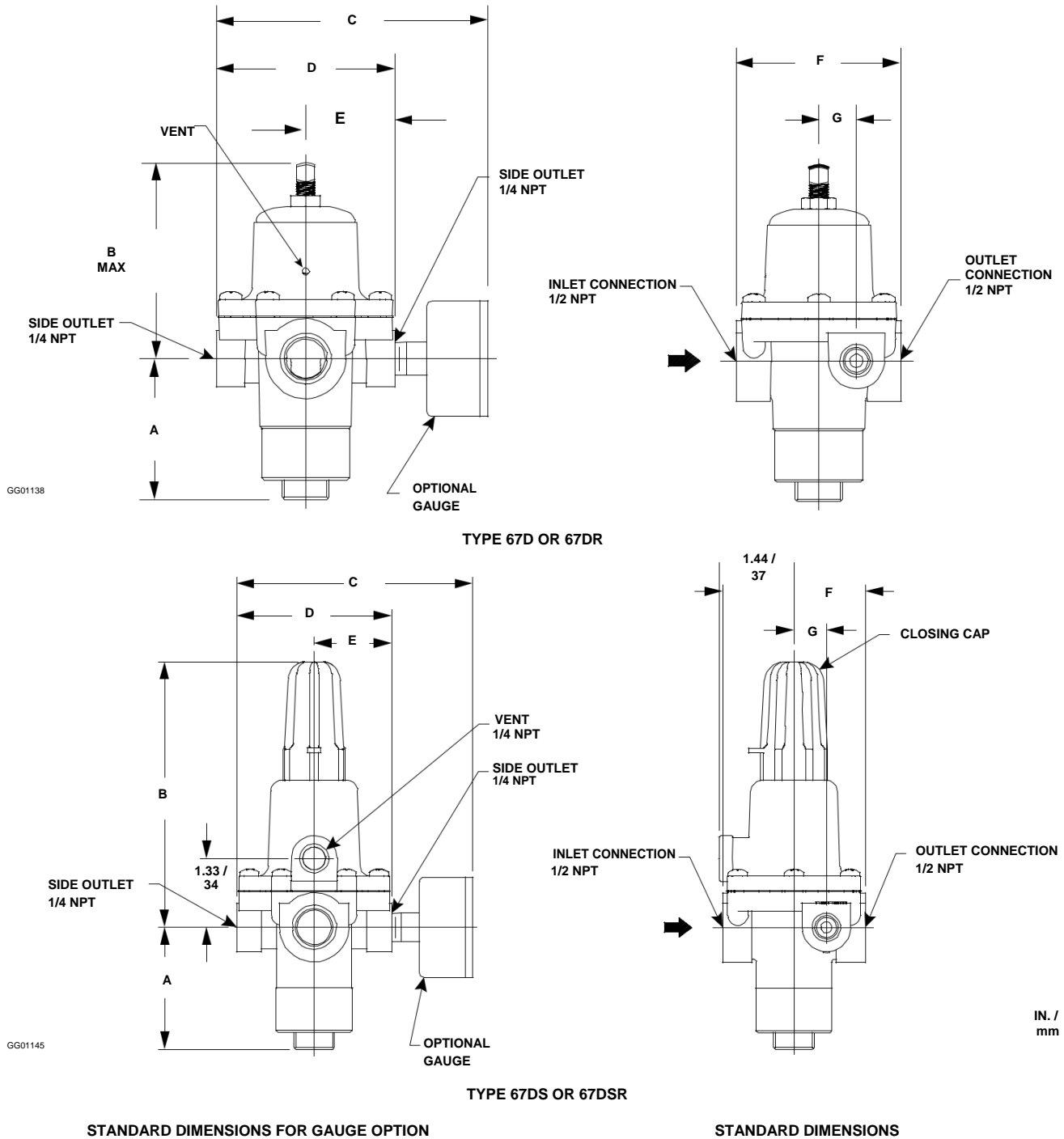

Figure 4. Types 67D, 67DR, 67DS and 67DSR Dimensions

Table 5. Types 67D, 67DR, 67DS and 67DSR Dimensions

TYPE	DIMENSION													
	A		B		C		D		E		F		G	
	In.	mm	In.	mm	In.	mm	In.	mm	In.	mm	In.	mm	In.	mm
67D and 67DR	2.35	60	3.66	93	4.54	115	2.98	76	1.49	38	2.75	70	0.63	16
67DS and 67DSR			5.12	130										



บริษัท เอดีดี เฟอร์เนส จำกัด

ADD FURNACE CO.,LTD.

44 ซอยบรมราชชนนี 70 ถนนบรมราชชนนี แขวงศาลาธรรมสพน์ เขตทวีวัฒนา กรุงเทพฯ 10170

โทร: 02-888-3472 โทร: ออกแบบ:08-08-170-170 แฟกซ์: 02-888-3258

https://www.add-furnace.com E-mail: [sales@add-furnace.com](mailto:sales@add-furnace.com)

# 67D Series

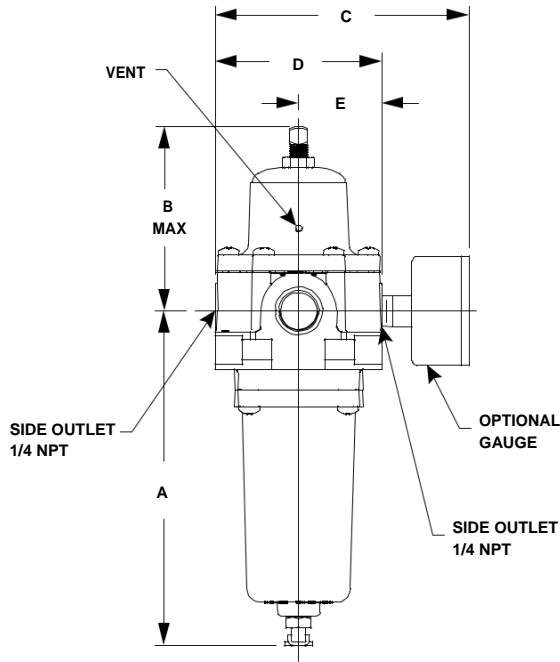

GG01139

TYPE 67DF OR 67DFR

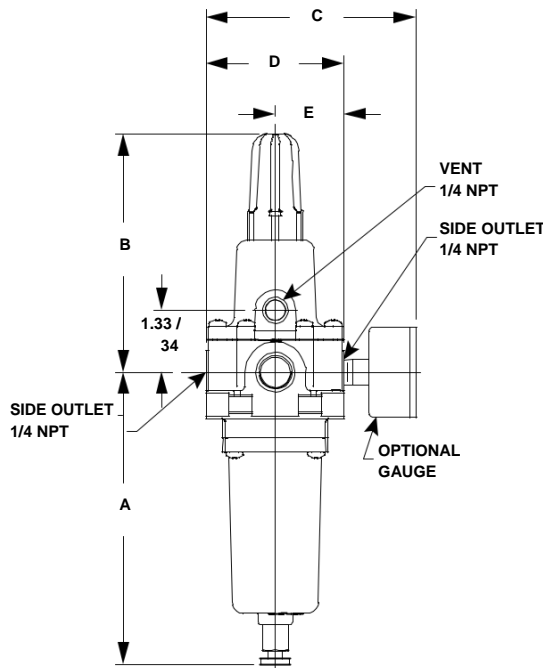
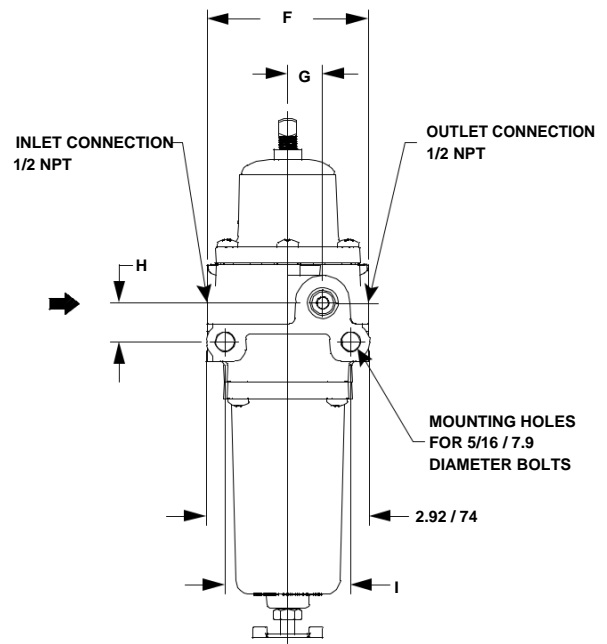

GG01135

TYPE 67DFS OR 67DFS R

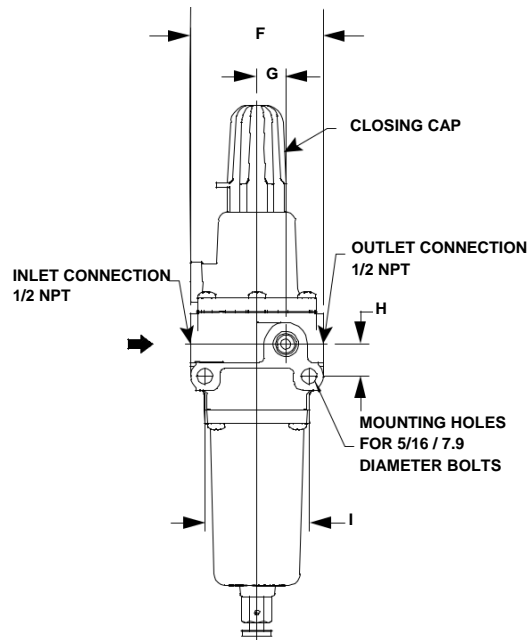

IN. / mm

STANDARD DIMENSIONS FOR GAUGE OPTION

STANDARD DIMENSIONS

Figure 5. Types 67DF, 67DFR, 67DFS and 67DFS R Dimensions

Table 6. Types 67DF, 67DFR, 67DFS and 67DFS R Dimensions

TYPE	DIMENSION																	
	A		B		C		D		E		F		G		H		I	
	In.	mm	In.	mm	In.	mm	In.	mm	In.	mm	In.	mm	In.	mm	In.	mm	In.	mm
67DF and 67DFR	5.93	151	3.66	93	4.54	115	2.98	76	1.49	38	2.88	73	0.63	16	0.69	18	2.25	57
67DFS and 67DFS R	6.27	159	5.12	130														