

CS400 Series Commercial / Industrial Pressure Reducing Regulators



Figure 1. Typical CS400 Pressure Reducing Regulators

Table of Contents

Introduction	1
Specifications.....	3
Principle of Operation	7
Installation and Overpressure Protection	8
Startup	11
Adjustment.....	11
Shutdown.....	12
Maintenance and Inspection.....	13
Parts Ordering	14
Parts List.....	14

Introduction

Scope of the Manual

This Instruction Manual provides installation, maintenance and parts ordering information for the CS400 Series regulators. Instructions and parts lists for other equipment mentioned in this Instruction Manual are found in separate manuals.

Table 1. Available Configurations

TYPE NUMBER					OPTIONS	
C	S	4	0			
						OVERPRESSURE PROTECTION MODULE
			0			Without Overpressure Protection Module
			3			With Integral Monitor Module ⁽¹⁾⁽³⁾
			4			With Slam-shut Module ⁽²⁾⁽³⁾
						PRESSURE REGISTRATION
				E		External Registration ⁽³⁾
				I		Internal Registration
						RELIEF
				N		Non-Relief
				T		Token Internal Relief
				R		Internal Relief
Example: Type number CS404IT: CS400 regulator constructed with Type VSX4 slam-shut module, with internal pressure registration and with token relief.						
1. Reference Instruction Manual D103126X012 for information regarding the Integral Monitor module.						
2. Reference Instruction Manual D103127X012 for information regarding the Type VSX4 safety shut-off module.						
3. Available only with Non-Relieving or Token Relief options, not Internal Relief.						

Table 2. Inlet Pressure Ratings and Flow and Sizing Coefficients

TYPE	ORIFICE SIZE		MAXIMUM OPERATING INLET PRESSURE		FLOW COEFFICIENTS (WIDE OPEN)		C ₁	IEC SIZING COEFFICIENTS		
	In.	mm	psig	bar	C _g	C _v		X _T	F _D	F _L
CS400, CS403 and CS404	3/16	4.8	125	8.6	27	0.97	27.7	0.50	0.91	0.89
	1/4	6.4	125	8.6	50	1.77	28.2	0.50	0.92	
	5/16	7.9	100	6.9	82	2.90	28.3	0.50	0.94	
	3/8	9.5	60	4.1	113	3.72	30.4	0.58	0.89	
	1/2	12	40	2.8	182	5.61	32.4	0.66	0.82	
	5/8	16	30	2.1	284	7.26	39.1	0.97	0.74	
	3/4	19	20	1.4	356	9.83	36.2	0.83	0.72	

! WARNING

Failure to follow these instructions or to properly install and maintain this equipment could result in an explosion and/or fire causing property damage and personal injury or death.

Fisher™ regulators must be installed, operated and maintained in accordance with federal, state and local codes, rules and regulations and Emerson Process Management, Inc. (Emerson) instructions.

If the regulator vents gas or a leak develops in the system, service to the unit may be required. Failure to correct trouble could result in a hazardous condition.

Call a gas service person to service the unit. Only a qualified person must install or service the regulator.

Description

CS400 Series regulators are typically installed on industrial and commercial applications. See Table 1 for available configurations. Constructions with External Registration, e.g., Type CS400EN, require an external control line.

Optional internal relief is available as well as low capacity token relief. Additional overpressure protection options include the Type CS403 that offers True-Monitor™ Protection, which is provided by an Integral Monitor installed on the inlet side of the valve body that assumes control of the pressure to the downstream system should the primary regulator cease to regulate downstream flow. The Type CS404 offers a slam-shut module that shuts off the flow of gas to the downstream system in the event of outlet pressure rising above or falling below the predefined levels.

Specifications

The Specifications section on the following page lists the specifications for the CS400 Series regulators. The following information is stamped on the regulator at the factory: type number, date of manufacture, spring range, orifice size, maximum inlet pressure, maximum operating outlet pressure and outlet pressure which may damage regulator parts.

<p>Available Configurations See Table 1</p> <p>Body Sizes, End Connection Styles and Pressure Rating⁽¹⁾ See Table 4</p> <p>Maximum Inlet Pressures⁽¹⁾ Emergency: 175 psig / 12.1 bar Operating: See Table 2</p> <p>Operating Pressure Ranges⁽¹⁾ Regulator: See Table 5 Integral Monitor Module: See Table 6 Slam-shut Module: See Tables 7 and 8</p> <p>Maximum Outlet Pressures⁽¹⁾ Emergency (Casing): 25 psig / 1.7 bar To Avoid Internal Parts Damage: 5 psig / 0.34 bar over set pressure Operating: 5.5 psig / 0.38 bar</p> <p>Flow Coefficients and Orifice Sizes See Table 2</p> <p>IEC Sizing Coefficients See Table 2</p> <p>Spring Case Vent Connection 1 NPT</p>	<p>Operating Temperature (TS)⁽¹⁾⁽²⁾ According to PED Standards: All Types: -4 to 150°F / -20 to 66°C Non-PED: All Types: -20 to 150°F / -29 to 66°C</p> <p>Pressure Registration Internal or External</p> <p>Approximate Weights With Threaded Body <i>Type CS400:</i> 9 lbs / 4 kg <i>Type CS403:</i> 18.5 lbs / 8 kg <i>Type CS404:</i> 11.2 lbs / 5 kg With Flanged Body Add 8.6 lbs / 4 kg to weights listed</p> <p>PED Conformity Statement and Information The CS400 Product Series is in conformity with the Pressure Equipment Directive PED 97/23/EC. The exception to this previous statement is the Type CS403 which is not yet certified to conform with the PED Directive. Pressure regulator does not require any supplementary upstream safety accessory for protection against overpressure compared with its design pressure PS, when upstream reducing station is sized for a max downstream incidental MIPd <= 1.1 PS.</p>
--	---

1. The pressure/temperature limits in this Instruction Manual and any applicable standard or code limitation should not be exceeded.
 2. Product has passed Emerson testing for lockup, relief start-to-discharge and reseal down to -40 degrees.

Table 3. PED Information

TYPE	DESCRIPTION	PED CATEGORY	FLUID GROUP
CS400	Base regulator	I	Groups 1 and 2 according to PED 97/23/EC, 1st and 2nd family gas according to EN 437 or other gases (compressed air, nitrogen). The gas must be non-corrosive, clean (filtration on inlet side necessary) and dry.
CS404	Regulator with Slam-Shut Module	IV	
European EN Reference Standards		EN 334, EN 14382	

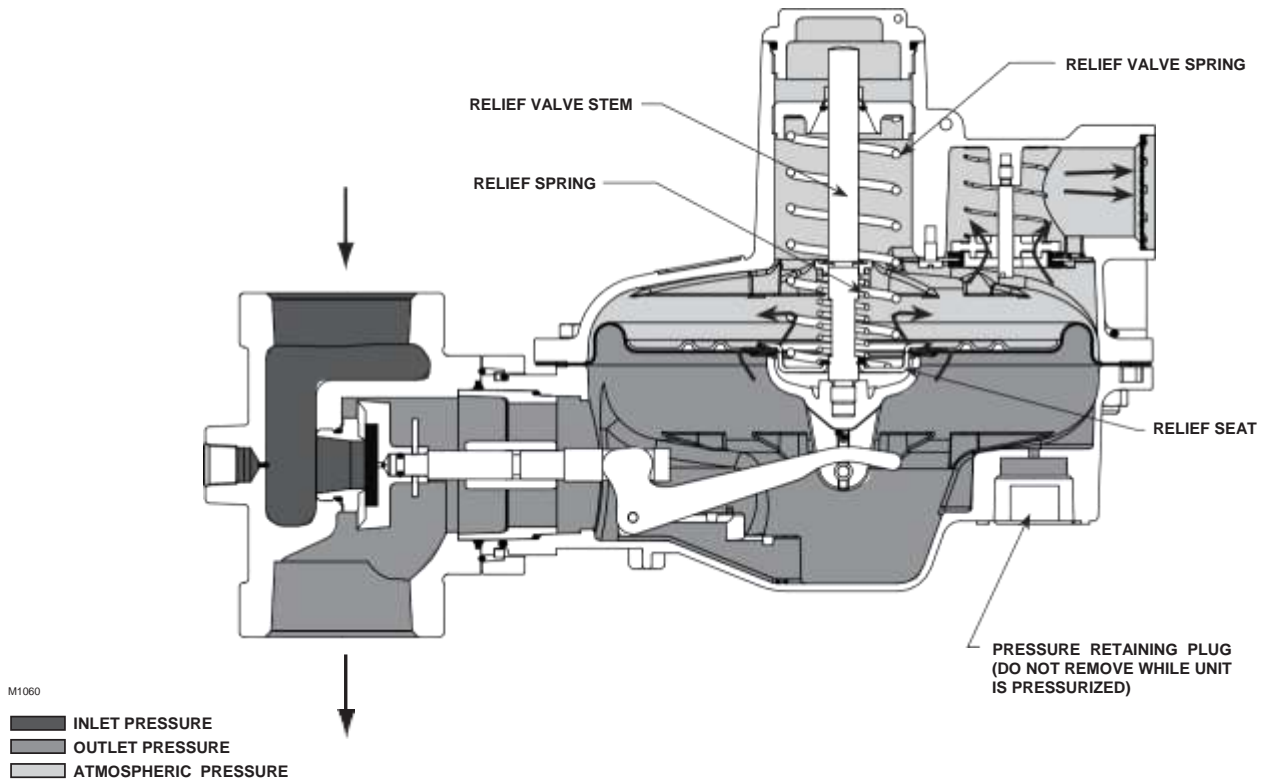

Figure 2. Type CS400IR Internally Registered Regulator with Internal Relief Operational Schematic

Table 4. Body Sizes, Material, End Connections and Pressure Ratings

BODY MATERIAL	INLET SIZE	OUTLET SIZE	END CONNECTION	FACE-TO-FACE DIMENSION		BODY PRESSURE RATING	
				In.	mm	psig	bar
Gray Cast Iron	1-1/4	1-1/4	NPT	4.5	114	175	12.1
	1-1/4	1-1/2					
	1-1/2	1-1/2					
	2	2					
	NPS 2 / DN 50	NPS 2 / DN 50	CL125 FF	10	254		
Ductile Iron	1-1/4	1-1/4	NPT	4.5	114	290	20.0
	1-1/2	1-1/2					
	2	2					
	1-1/4	1-1/4	Rp	4.5	114		
	1-1/2	1-1/2					
	2	2					
		NPS 2 / DN 50	NPS 2 / DN 50	CL125 FF / CL150 FF	10		
			PN 10/16	10	254	232	16.0
Steel	1-1/4	1-1/4	NPT	4.5	114	290	20.0
	1-1/2	1-1/2					
	1-1/4	1-1/4	Rp	4.5	114		
	1-1/2	1-1/2					

Table 5. Outlet Pressure Ranges

TYPE	OUTLET PRESSURE RANGE		PART NUMBER	SPRING COLOR	SPRING WIRE DIAMETER		SPRING FREE LENGTH	
	In. w.c.	mbar			In.	mm	In.	mm
CS400, CS403 and CS404	3.5 to 5	9 to 12	GE30198X012	Red	0.098	2.49	4.18	106
	4.5 to 6.5	11 to 16	GE30195X012	Purple	0.080	2.03	4.32	110
	6 to 8	15 to 20	GE30188X012	Gold	0.108	2.74	4.18	106
	7.5 to 11	19 to 27	GE30189X012	Blue	0.110	2.79	4.40	112
	10 to 14	25 to 35	GE30224X012	Unpainted	0.110	2.79	4.40	112
	12 to 19	30 to 47	GE30196X012	Green	0.112	2.85	4.70	119
	18 in. w.c. to 1 psig	45 to 69	GE30225X012	Orange	0.120	3.05	4.94	125
	1 to 2 psig	69 to 138	GE30190X012	Black	0.140	3.56	4.66	118
2 to 5.5 psig	138 to 380	GE30197X012	Yellow	0.172	4.37	4.42	112	

Table 6. Type CS403 Regulator and Integral Monitor Outlet Pressure Ranges

TYPE	PRIMARY REGULATOR				INTEGRAL MONITOR					
	Setpoint		Spring Part Number	Spring Color	Setpoint ⁽¹⁾		Spring Part Number	Spring Range		Spring Color
	In. w.c.	mbar			In. w.c.	mbar		In. w.c.	mbar	
CS403	4	10	GE30198X012	Red	14	35	GE30189X012	12 to 21	30 to 52	Blue
	5	12	GE30195X012	Purple						
	7	17	GE30188X012	Gold						
	11	27	GE30189X012	Blue	21	52	GE30196X012	18 to 30	45 to 75	Green
	14	35	GE30224X012	Unpainted						
	18	45	GE30196X012	Green	1 psig	69	GE30225X012	26 to 40	65 to 99	Orange
	1 psig	69	GE30225X012	Orange	1.5 psig	103	GE30190X012	1.4 to 2.9 psig	97 to 200	Black
	2 psig	138	GE30190X012	Black	2.5 psig	172	GE30190X012	1.4 to 2.9 psig	97 to 200	Black
	3 psig	207	GE30197X012	Yellow	3.5 psig	241	GE35081X012	2.6 to 3.7 psig	179 to 255	Purple
	4 psig	276	GE30197X012		5 psig	345	GE30192X012	3.6 to 6 psig	248 to 414	Dark Blue
5 psig	345	GE30197X012	6 psig		414	GE33121X012	5.1 to 7.5 psig	352 to 517	Red	

1. Integral Monitor setpoints shown represent the minimum setpoint difference between the Integral Monitor and the Primary regulator. Higher monitor setpoints can be chosen, e.g., for Primary regulator setpoint of 7 in. w.c. / 17 mbar, the Integral Monitor can also be set at 14, 21 in. w.c., 1 psig / 35, 52, 69 mbar or higher.

Table 7. Type CS404 Regulator and Slam-shut OPSO Pressure Ranges

TYPE	REGULATOR				SLAM-SHUT DEVICE				
	Setpoint		Spring Range		Factory Setpoint ⁽¹⁾		Overpressure Shutoff (OPSO)		Spring Part Number
	In. w.c.	mbar	In. w.c.	mbar	In. w.c.	mbar	In. w.c.	mbar	
CS404	4	10	3.5 to 5	9 to 12	18	45	12 to 25	30 to 60	GF02168X012
	5	12	4.5 to 6.5	11 to 16	19	47			
	7	17	6 to 8	15 to 20	21	52			
	11	27	7.5 to 11	19 to 27	0.9	62	0.58 to 1.6 psig	40 to 110	GF02169X012
	14	35	10 to 14	25 to 35	1.1	75			
	0.65 psig	45	0.45 to 0.7 psig	30 to 47	1.4 psig	96	30 to 44	75 to 110	GF02170X012
	0.72 psig	50	0.65 to 1 psig	45 to 69	1.6 psig	112			
	1 psig	69			2.5 psig	172	1.4 to 4.1 psig	95 to 280	GF02171X012
	1.5 psig	103	3.0 psig	207					
	2 psig	138	3.5 psig	241					
3 psig	207	1 to 2 psig	69 to 138	6.3 psig	434	3.2 to 11 psig	220 to 760	GF02173X012	
4 psig	276			7.3 psig	503				
5 psig	345			8.3 psig	572				
5.5 psig	380			8.8 psig	606				

1. For Types CS404IT and CS404ET equipped with Token Relief, if Non-Factory slam-shut OPSO setpoints are specified, they must not encroach on the Token Relief Start-to-Discharge values provided in Table 4 of the CS400 Bulletin.

Table 8. Type CS404 Regulator and Slam-shut OPSO and UPSO Pressure Ranges

TYPE	REGULATOR				SLAM-SHUT DEVICE									
	Setpoint		Spring Range		Overpressure Shutoff (OPSO)				Underpressure Shutoff (UPSO)					
	Factory Setpoint ⁽¹⁾		Range		Spring Part Number	Factory Setpoint		Range		Spring Part Number				
	psig	mbar	psig	mbar		psig	mbar	psig	mbar					
CS404	0.51	35	0.36 to 0.51	25 to 35	1.1	75	0.73 to 1.9	50 to 130	GF02168X012	0.32	22	0.14 to 1.1	10 to 75	T14169T0012
	0.65	45	0.45 to 0.70	30 to 48	1.4	96				0.4	30			
	0.72	50	0.65 to 1	45 to 69	1.6	112				0.4	30			
	1	69			2.5	172	0.58	40	0.36 to 2.3	25 to 159	T14170T0012			
	1.5	103	3.0	207	2.2 to 5.5	150 to 380						GF02170X012	0.73	50
	2	138	3.5	241			6.3	434	GF02171X012	1	69			
	3	207	6.3	434	3.8 to 8.7	262 to 600				GF02171X012	1.75	121		
	4	276	7.3	503			5.8 to 16	400 to 1100	GF02172X012		2	140		
	5	345	8.3	572	1.5 to 7.3	100 to 500				FA142869X12	2.9	200		
	5.5	380	8.8	606			3.6	250						

1. For Types CS404IT and CS404ET equipped with Token Relief, if Non-Factory slam-shut OPSO setpoints are specified, they must not encroach on the Token Relief Start-to-Discharge values provided in Table 4 of the CS400 Bulletin.

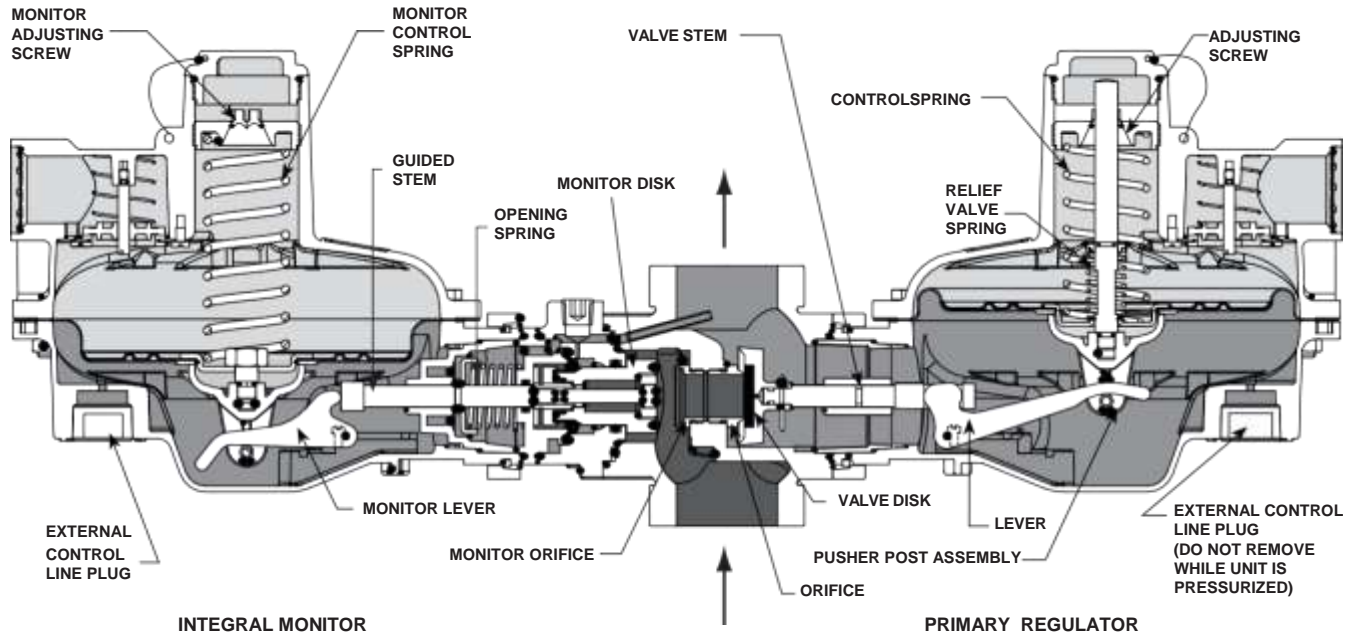

M1061

Figure 3. Type CS403 Internally Registered Primary Regulator with Internally Registered Integral Monitor Operational Schematic

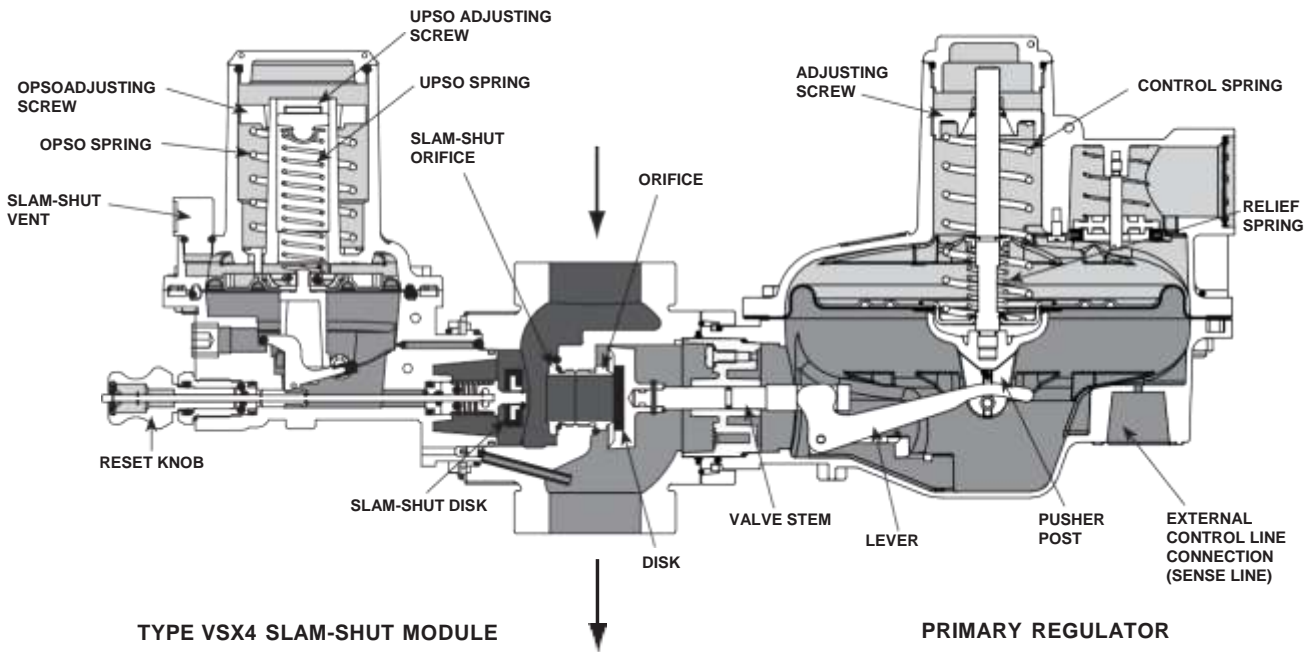

M1063

- INLET PRESSURE
- OUTLET PRESSURE
- ATMOSPHERIC PRESSURE

Figure 4. Type CS404ET Externally Registered Regulator with Slam-shut Operational Schematic

Principle of Operation

Type CS400 Base Regulator Operation

Refer to Figure 2. When downstream demand decreases, the pressure under the diaphragm increases. This pressure overcomes the regulator setting (which is set by the regulator control spring). Through the action of the pusher post assembly, lever and valve stem, the valve disk moves closer to the orifice and reduces gas flow. If demand downstream increases, pressure under the diaphragm decreases. Spring force pushes the pusher post assembly downward, the valve disk moves away from the orifice and the gas flow increases downstream as the regulator opens in response to the decreased pressure underneath the diaphragm.

The Type CS400IR regulator includes an internal relief valve for overpressure protection. If the downstream pressure exceeds the regulator setting by 7 to 28 in. w.c. / 17 to 69 mbar (depending on the main spring used), the relief valve opens and excess gas is vented through the stabilizer vent in the upper spring case.

The Types CS400IT and CS400ET provide a low capacity/token relief. Token relief provides relief from minor overpressure caused by nicks or dents on the orifice or by thermal expansion of gas in the downstream line. Token relief also provides a token or signal, in the form of odor, that an overpressure situation is occurring.

Type CS403 Integral Monitor Operation

Type CS403 combines the operation of a conventional two-regulator wide-open monitor set into one body, see Figure 3. The Integral True-Monitor™ is installed on the inlet side of the body and serves to throttle flow and maintain an acceptable downstream pressure in the case where the Primary regulator fails to regulate downstream pressure. During normal operation the Integral Monitor is in a wide-open state as its setpoint is set higher than the primary regulator. See Table 6 for guidance regarding the setpoints of the regulator and associated integral monitor sets. If the downstream pressure should rise to the setpoint of the internal monitor due to loss of pressure

control by the primary regulator, the integral monitor will assume control and regulate the flow to the downstream system. See the Type TM600 Instruction Manual for additional details of operation.

If token relief is present, it will relieve a small amount of gas to the atmosphere as an indication that the Integral monitor is controlling the downstream pressure.

Type CS404 Slam-shut Operation

The Type VSX4 slam-shut module on the Type CS404 regulator is a fast acting shut-off device that provides overpressure (OPSO) or over and underpressure (OPSO / UPSO) protection by completely shutting off the flow of gas to the downstream system. See Tables 7 and 8 for guidance regarding the typical setpoints of the regulator and associated OPSO and UPSO setpoints. The Type VSX4's actions are independent of the Type CS404 regulator and of variations to the inlet pressure. The Type VSX4 provides the option of internal or external downstream pressure registration. External registration requires a downstream sensing line. See Figure 7 for guidance regarding installation of the downstream control line.

The Type VSX4 shut-off disk is normally in the open (reset) position, see Figure 4. If the downstream pressure below the slam-shut diaphragm increases (or decreases) until it reaches the slam-shut setpoint, this diaphragm moves upward (or downward) to release the trip mechanism which allows the spring force on the stem to push the disk against the seat, shutting off all gas flow. To reset the slam shut after gas has been shutoff, refer to Type VSX4 Instruction Manual for additional details.

In order for the Underpressure Shutoff (UPSO) of any slam-shut to be triggered, the downstream pipe pressure must drop below the UPSO setpoint. In the case of a downstream line break, numerous factors can prevent the downstream pipe pressure from decreasing below the slam-shut UPSO setpoint. These factors include the distance of pipe to the break, the diameter of the pipe, size of the break and the number of restrictions, such as valves, elbows and bends, downstream of the regulator and/or slam-shut device. Due to these factors additional protections should be installed to stop flow in the event of a line break.

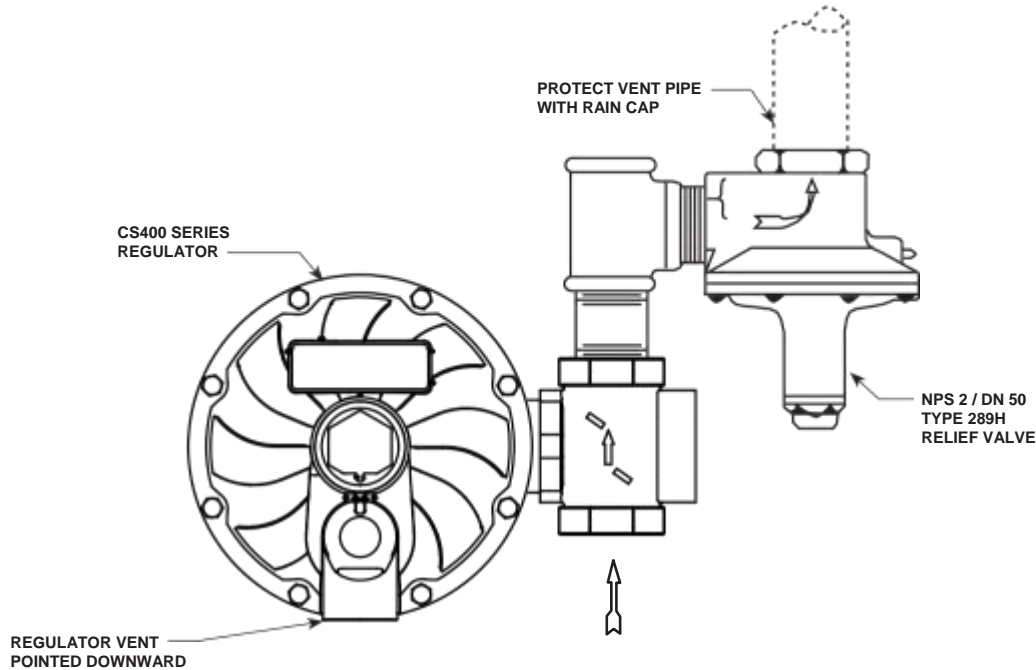

Figure 5. CS400 Series Regulator Installed with the Vent Pointed Downward and with a Type 289H Relief Valve for High Capacity Relief

Installation and Overpressure Protection

! WARNING

Personal injury or system damage may result if this regulator is installed, without appropriate overpressure protection, where service conditions could exceed the limits given in the Specifications section and/or regulator nameplate.

Regulator installations should be adequately protected from physical damage.

All vents should be kept open to permit free flow of gas to the atmosphere. Protect openings against entrance of rain, snow, insects or any other foreign material that may plug the vent or vent line. On outdoor installations, point the spring case vent downward to allow condensate to drain (see Figures 5 through 7).

This minimizes the possibility of freezing and of water or other foreign materials entering the vent and interfering with proper operation.

For the Type CS403 with the Integral Monitor or the Type CS404 with slam shut, point the vents of both the Primary Regulator and Integral Monitor or slam shut downward to allow condensate to drain. From the factory, the Integral Monitor or slam shut will always point in the same direction as that of the Primary Regulator.

Under enclosed conditions or indoors, escaping gas may accumulate and be an explosion hazard. In these cases, the vent should be piped away from the regulator to the outdoors.

CAUTION

The CS400 Series regulators have an outlet pressure rating lower than their inlet pressure rating. If actual inlet pressure can exceed the outlet pressure rating, outlet overpressure protection is necessary. However, overpressuring any portion of the regulators beyond the limits in Specifications section may cause leakage, damage to regulator parts or personal injury due to bursting of pressure-containing parts.

Some type of external overpressure protection should be provided to the CS400 Series if inlet pressure will be high enough to damage downstream equipment. Common methods of external overpressure protection include relief valves, monitoring regulators, shut off devices and series regulation.

If the regulator is exposed to an overpressure condition, it should be inspected for any damage that may have occurred. Regulator operation below these limits does not preclude the possibility of damage from external sources or from debris in the pipeline.

General Installation Instructions

Before installing the regulator,

- Check for damage, which might have occurred during shipment.
- Check for and remove any dirt or foreign material, which may have accumulated in the regulator body.
- Blow out any debris, dirt or copper sulfate in the copper tubing and the pipeline.
- Apply pipe compound to the male threads of the pipe before installing the regulator.
- Make sure gas flow through the regulator is in the same direction as the arrow on the body. "Inlet" and "Outlet" connections are clearly marked.
- When designing a pressure reducing station using a CS400 Series regulator, make an analysis if it is necessary to take into account the effects of wind, snow and temperature to avoid unnecessary load and movement to the flanges of the equipment.

- If needed, a support may be used under the piping and regulator/slam-shut body to avoid excessive pressure force on the regulator/slam shut.

Installation Location

- The installed regulator should be adequately protected from vehicular traffic and damage from other external sources.
- **Install the regulator with the vent pointed vertically down, see Figures 5 through 7.** If the vent cannot be installed in a vertically down position, the regulator must be installed under a separate protective cover. Installing the regulator with the vent down allows condensation to drain, minimizes the entry of water or other debris from entering the vent and minimizes vent blockage from freezing precipitation.
- **Do not install the Types CS400, CS403 or CS404 in a location where there can be excessive water accumulation or ice formation,** such as directly beneath a downspout, gutter or roof line of building. Even a protective hood may not provide adequate protection in these instances.
- Install the Regulator so that any gas discharge through the vent or vent assembly is over 3 ft / 0.91 meters away from any building opening.

Regulators Subjected to Heavy Snow Conditions

Some installations, such as in areas with heavy snowfall, may require a hood or enclosure to protect the regulator from snow load and vent freeze over.

Downstream Control Line Installation

A CS400 Series regulator with an EN or ET in the type number has a blocked throat, an O-ring stem seal and a 3/4 NPT control line tapping in the lower diaphragm casing. A regulator with a downstream control line is used for monitoring installations or other applications where there is other equipment installed between the regulator and the pressure control point.

For Types CS400ET and CS400EN regulators, connect downstream control line tubing to the lower casing and run the tubing approximately 20 in. / 508 mm downstream. For best results, the outer diameter of the control line tubing should be 3/8 in. / 9.5 mm or larger.

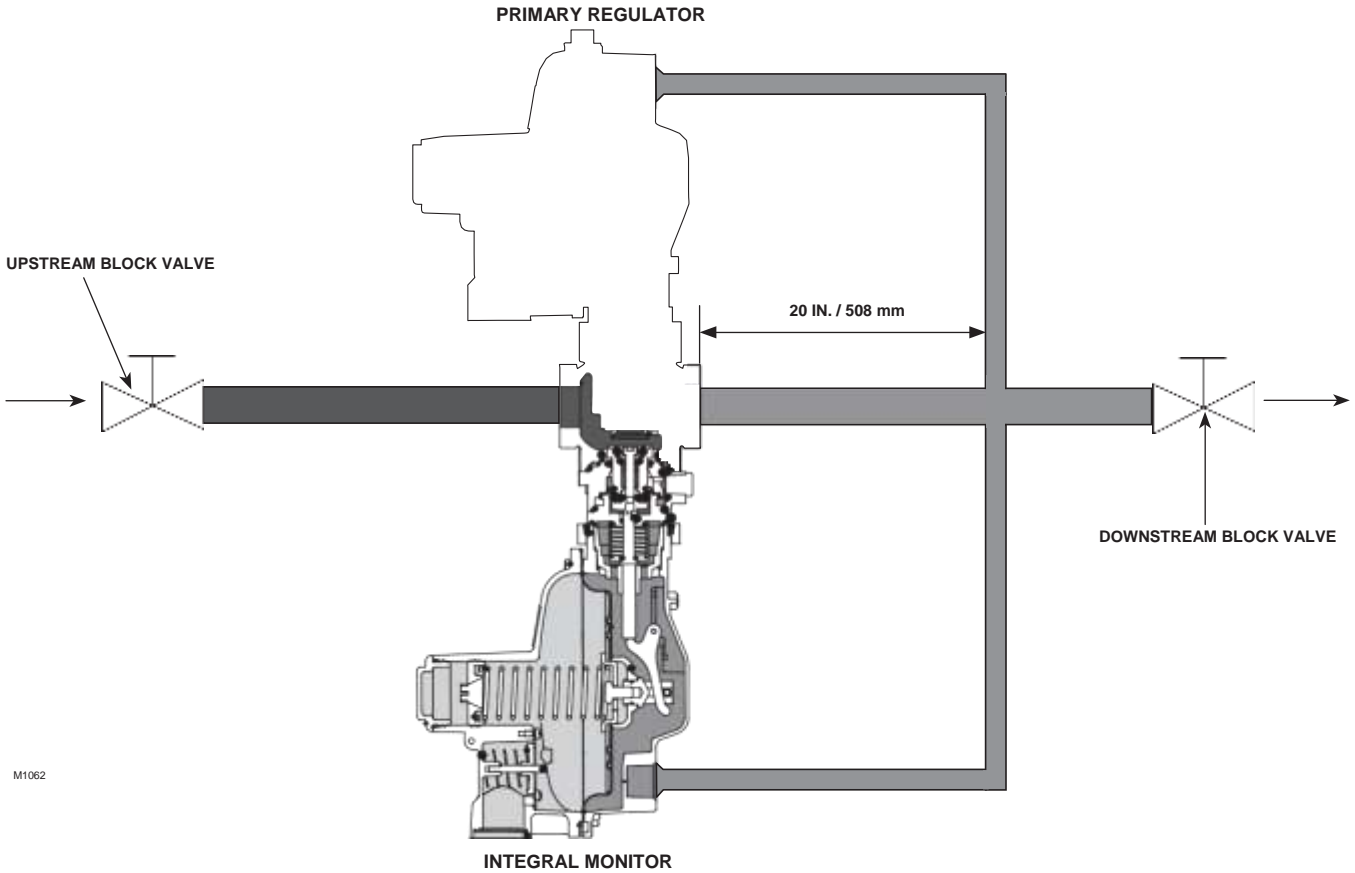

Figure 6. Type CS403 Downstream Control Line Connection

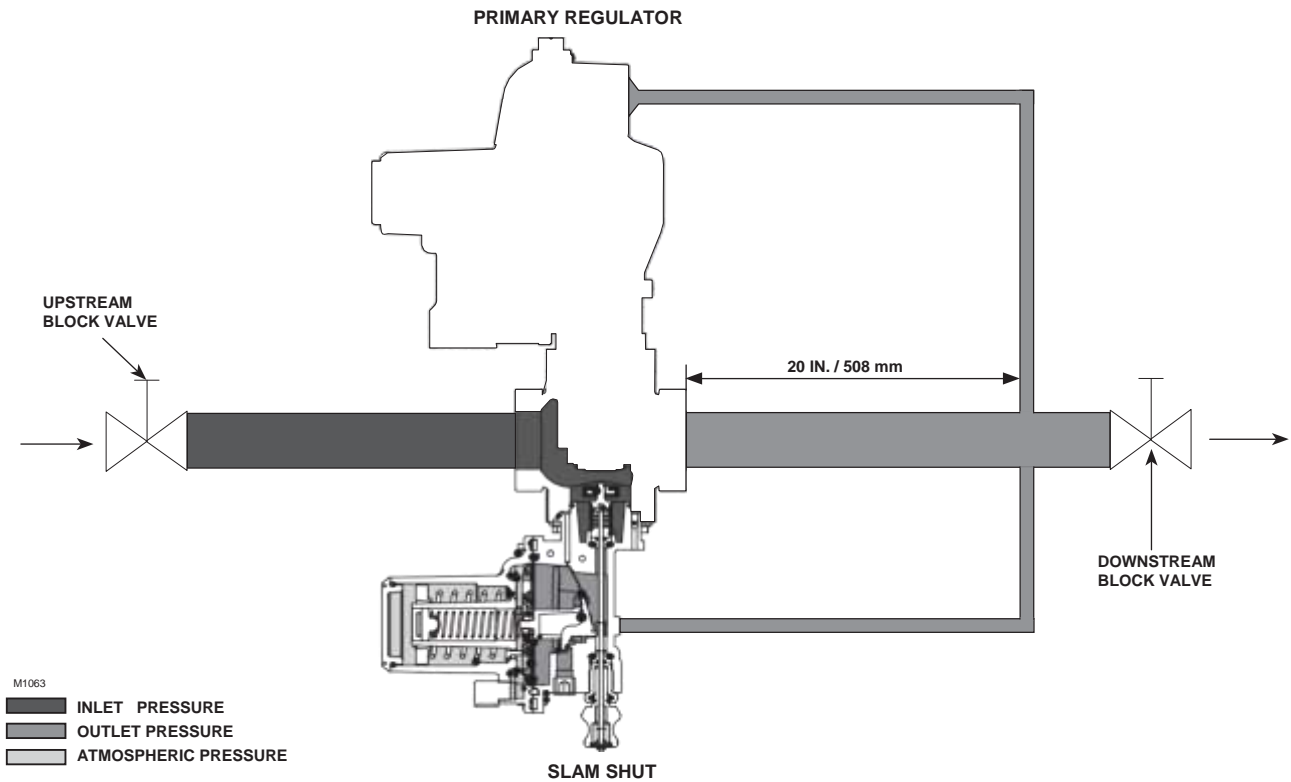

Figure 7. Type CS404 Downstream Control Line Connection

Downstream Control Line Installation with Integral Monitor

Refer to Figure 6. When installing the Types CS403ET and CS403EN regulators, connect downstream control line tubing to the lower casing of the Primary Regulator and run the tubing approximately 20 in. / 508 mm downstream. Connect a second, separate downstream control line tubing to the lower casing of the Integral Monitor and run the tubing approximately 20 in. / 508 mm downstream. For best results, the outer diameter of the control line tubing for both the Primary Regulator and the Integral Monitor should be 3/8 in. / 9.5 mm or larger.

Downstream Control Line Installation with Slam shut

Refer to Figure 7. When installing the Types CS404ET and CS404EN regulators, connect downstream control line tubing to the lower casing of the Regulator and run the tubing approximately 20 in. / 508 mm downstream. Connect a second, separate downstream control line tubing to the lower casing of the slam shut and run the tubing approximately 20 in. / 508 mm downstream. For best results, the outer diameter of the control line tubing for the regulator should be 3/8 in. / 9.5 mm or larger. The outer diameter of the control line tubing for the slam shut should be 1/4 in. / 6.4 mm or larger.

Installation with External Overpressure Protection

If the regulator is used in conjunction with a Type 289H relief valve, it should be installed as shown in Figure 5. The outside end of the vent line should be protected with a rainproof assembly. The Type 289H should be set 10 in. w.c. / 25 mbar higher than the outlet pressure setting of the regulator, up to 30 in. w.c. / 75 mbar outlet pressure. For pressure greater than this, set the Type 289H 0.75 psi / 0.05 bar higher than the outlet pressure setting of the regulator.

Vent Line Installation

The CS400 Series regulators have a 1 NPT screened vent opening in the spring case. If necessary to vent escaping gas away from the regulator, install a remote vent line in the spring case tapping. Vent piping should be as short and direct as possible with a minimum number of bends and elbows. The remote vent line should have the largest practical diameter. Vent piping on regulators with internal relief must be large enough to vent

all relief valve discharge to atmosphere without excessive backpressure and resulting excessive pressure in the regulator.

The Type CS403 offers an optional token relief. This optional low capacity relief is located in the spring case of the Primary Regulator. If necessary to vent escaping gas away; install a remote vent line in the spring case tapping of the Primary Regulator as described above.

Periodically check all vent openings to be sure that they are not plugged.

CS400 Series Outlet pressure ranges are shown in Table 5. Outlet pressure greater than 5 psi / 0.34 bar above setpoint may damage internal parts such as the diaphragm head and valve disk. **The maximum emergency (casing) outlet pressure is 25 psig / 1.7 bar.**

Startup

CAUTION

Pressure gauges should always be used to monitor downstream pressure during Startup.

With the downstream system depressurized, use the following procedure to startup the regulator:

1. Check to see that all appliances are turned off.
2. Slowly open the upstream shut-off valve.
3. Check inlet and outlet pressure for correct values.
4. Check all connections for leaks.
5. Turn on utilization equipment and recheck the pressures.

Adjustment

Note

For Types that include the Integral Monitor module, refer to the instruction manual for Type TM600 Integral Monitor for Adjustment and Maintenance of the Integral Monitor. For Types that include the slam-shut module, refer to the instruction manual for Type VSX4 slam shut for Adjustment and Maintenance of the slam shut.

The range of allowable pressure settings is stamped on the nameplate. If the required setting is not within this range, substitute the correct spring (as shown in Table 5). If the spring is changed, change the nameplate to indicate the new pressure range.

A pressure gauge should always be used to monitor downstream pressure while adjustments are being made.

1. Remove the closing cap (key 60, Figure 8).
2. To increase the outlet setting, turn the adjusting screw (key 65, Figure 8) clockwise. To decrease the outlet setting, turn the adjusting screw counterclockwise.
3. Replace the closing cap.

CS400 Series with Integral Monitor Module

When adjusting the Primary Regulator and Integral Monitor for operation, ensure that the pressure differences between the Primary Regulator and the integral monitor shown in Table 6 are observed. For example, if the Primary Regulator setpoint is set at 7 in. w.c. / 17 mbar, then the Integral Monitor should be set at a minimum of 14 in. w.c. / 35 mbar or higher.

To test the Integral Monitor operation, the Primary regulator setpoint must be adjusted above the Integral Monitor's setpoint to simulate a failure of the primary regulator. If the spring range of the Primary Regulator is sufficiently high, it can simply be adjusted above the Integral Monitor's setpoint by following step 2 above. Otherwise, a different spring with a setpoint higher than the Integral Monitor's setpoint must be installed to check the operation of the Integral Monitor.

CS400 Series with Slam-shut Module

When adjusting the primary regulator and slam shut for operation, reference Tables 7 and 8 for the OPSO and UPSO setpoints of the slam shut for the given regulator spring ranges.

! WARNING

In the case of a downstream line break, numerous factors affect the capability to evacuate gas from the pipeline. These factors include the distance of pipe to the break, the diameter of the pipe, size of the break and the number of restrictions, such as valves, elbows and bends, downstream

of the regulator and/or slam-shut device. Due to these factors additional protections should be installed to stop flow in the event of a line break.

CAUTION

Equipment installed downstream the Type VSX slam shut device can be damaged if the following procedure for resetting the Type VSX slam shut device is not followed. This equipment includes the integral Type VSX regulator configurations.

Step 1:

To properly reset the Type VSX slam shut after it has been tripped to the closed position, a flat-head screwdriver must be inserted into the position shown in Figure 8 on the backside of the reset button (key 30, Figure 8).

Step 2:

The screwdriver should be slowly rotated to gradually pull the reset button (key 30) away from the Type VSX device. This slow movement allows for a slow bleed of the pressure across the Type VSX slam shut's disk and seat area. The operator should be able to hear the pressure bleeding through the system.

Step 3:

When the pressure has equalized and the air bleeding sound has dissipated, the reset button (key 30) should be pulled completely away from the Type VSX slam shut device by hand until the internal shut-off mechanism has been re-latched.

Step 4:

Once the operator feels the click of the re-latch occurring, the reset button (key 30) should be pushed completely back into its original position.

Shutdown

Installation arrangements may vary, but in any installation it is important that the valves be opened or closed slowly and that the outlet pressure be vented before venting inlet pressure to prevent damage caused by reverse pressurization of the regulator. The steps in the following page apply to the typical installation as indicated.

1. Open valves downstream of the regulator.
2. Slowly close the upstream shut-off valve.
3. Inlet pressure will automatically be released downstream as the regulator opens in response to the lowered pressure on the diaphragm.

Maintenance and Inspection

! WARNING

To avoid personal injury or equipment damage, do not attempt any maintenance or disassembly without first isolating the regulator from system pressure and relieving all internal pressure as described in “Shutdown”.

Regulators that have been disassembled for repair must be tested for proper operation before being returned to service. Only parts manufactured by Emerson should be used for repairing Fisher™ regulators. Relight pilot lights according to normal startup procedures.

Due to normal wear or damage that may occur from external sources, this regulator should be inspected and maintained periodically. The frequency of inspection and replacement of parts depends upon the severity of service conditions or the requirement of local, state and federal rules and regulations.

Periodic inspection must be performed on the Types CS403 and CS404 to ensure that the integral monitor or slam-shut overpressure protection modules, respectively, protect the downstream system in the event of a failure to the primary regulator. This inspection must test that the integral monitor or slam-shut functions as intended. The frequency of this inspection must be at intervals not exceeding 15 months, but at least once each calendar year.

Disassembly to Replace Diaphragm

1. Remove the closing cap (key 60, Figure 8). Turn the adjusting screw (key 65) counterclockwise to ease spring compression.
2. Remove the adjusting screw (key 65) and control spring (key 38).

3. Remove hex nuts (key 16) and cap screws (key 15). Separate the upper spring case (key 1) from the lower casing assembly (key 9).

Note

If disassembling a CS400 Series regulator, lift the upper spring case straight up in order to avoid hitting the stem (key 44).

4. Slide the diaphragm head assembly (key 55) away from the body (key 70) to unhook the pusher post (key 51) from the lever (key 10). Lift off the diaphragm head assembly (key 55).
5. **For none relieving units such as the Types CS400IN and CS400EN**, unscrew the screw retainer (key 45, Figure 9) using a 5/8 in. / 16 mm wrench. The screw retainer fastens the lower spring seat (key 43) to the pusher post (key 51). Unscrewing the screw retainer will separate the lower spring seat (key 43), diaphragm head assembly (key 55) and pusher post (key 51). **For units with internal relief such as Type CS400IR**, press down on the upper spring retainer (key 42, Figure 10) using a 9/16 in. / 14 mm box-end wrench and remove the E-ring (key 58). Slide the upper spring retainer (key 42), the relief spring (key 41), the lower spring seat (key 43) and the diaphragm assembly (key 55) off of the relief valve stem (key 44).
6. Reassemble in reverse order of the above steps.

Disassembly to Replace Valve Disk and Orifice

1. Remove the cap screws (key 71, Figure 8) which hold the lower spring casing (key 9) to the body (key 70). Separate the lower casing (key 9) from the body.
2. Check the body O-ring (key 21) for wear and replace as necessary.
3. Examine the valve disk (key 36) for nicks, cuts and other damage. Remove the disk clip (key 37) that holds the disk to the stem (key 11) and replace the disk if necessary.
4. Examine the seating edge of the orifice (key 25). If it is nicked or rough, remove the orifice (key 25) from the body (key 70) using a 1-1/16 in. / 27 mm socket wrench. Coat the threads of the replacement orifice with a good quality lubricant and install.

5. Change to a new part when reassembling the regulator. Coat the threads of the replacement orifice with a good quality lubricant. (If the orifice is being replaced with a different size, update the nameplate to state the new size and maximum inlet pressure).
6. Reassemble the regulator in reverse order of the above steps.

Regulator Reassembly

As indicated by the square callouts in Figures 8 through 12, it is recommended that a good quality pipe thread sealant be applied to pressure connections and fittings and a good quality lubricant be applied to O-rings. Also apply an anti-seize compound to the adjusting screw threads and other areas as needed.

Parts Ordering

The type number, orifice size, spring range and date of manufacture are stamped on the nameplate. Always provide this information in any correspondence with your local Sales Office regarding replacement parts or technical assistance.

When ordering replacement parts, reference the key number of each needed part as found in the following parts list. Separate kit containing all recommended spare parts is available.

Parts List

Key	Description	Part Number
	Regulator Repair Kit (Repair Parts Kit include keys 19, 21, 27, 36, 55 and 62)	
	Type CS400	RCS400X0012
	Type CS403	RCS403X0012
	Type CS404	RCS404X0012
	Orifice Repair Kit (Orifice Repair Parts kit includes keys 25 (Orifice) and 27 (O-ring, Quantity 1))	
	3/16 in. / 4.8 mm orifice size	GE31360X012
	1/4 in. / 6.4 mm orifice size	GE31361X012
	5/16 in. / 7.9 mm orifice size	GE31362X012
	3/8 in. / 9.5 mm orifice size	GE31363X012
	1/2 in. / 13 mm orifice size	GE31364X012
	5/8 in. / 16 mm orifice size	GE31365X012
	3/4 in. / 19 mm orifice size	GE31366X012

Key	Description	Part Number
1	Spring Case, Aluminum	GE24555X012
2	Vent Screen, Stainless steel	T1121338982
3	Retaining Ring, Zinc-plated steel	T1120925072
4	Stabilizer Guide, Stainless steel	GE27061X012
5	Stabilizer	GE27063X012
6	Stabilizer Spring, Stainless steel	GE35010X012
7	Stabilizer Retaining Ring, Zinc-plated steel	GE27024X012
8	Stabilizer Screw (3 required), Zinc-plated	GE29724X012
9	Lower Casing, Aluminum	GE24289X012
10	Lever, Steel	GE27194X012
11	Stem, Aluminum	GE27402X012
12*	O-ring, External Registration, Nitrile (NBR)	1E472706992
13	Lever Pin, Stainless steel	T14397T0012
14	Lever Screw (2 required), Zinc-plated steel	GE34243X012
15	Cap Screw (8 required), Steel	GE32059X012
16	Nut (8 required), Steel	GE32060X012
17	Union Ring, Aluminum	GE26590X012
18	Snap Ring, Stainless steel	T1120637022
19*	O-ring, Nitrile (NBR)	1K594906562
20	Stem Guide, Aluminum Internal Registration (Open Throat) External Registration (Closed Throat)	GE25384X012 GE25385X012
21*	O-ring, Nitrile (NBR)	GE45216X012
22	Pipe Plug, 3/4 NPT, Steel Internal Registration	GE34199X012
23	Screw, External Registration, Zinc-plated steel	1E175828982
24*	O-ring, External Registration, Nitrile (NBR)	17A0960X012
25*	Orifice, Aluminum 3/16 in. / 4.8 mm 1/4 in. / 6.4 mm 5/16 in. / 7.9 mm 3/8 in. / 9.5 mm 1/2 in. / 13 mm 5/8 in. / 16 mm 3/4 in. / 19 mm	T1122409012 T12522T0012 GE31233X012 T1122309012 T1122009012 GE31234X012 T1121909012
26*	OPP Orifice, 3/4 in. / 4.8 mm True-Monitor™, Aluminum Type VSX4, Brass	GE30003X012 GE28684X012
27*	O-ring, Nitrile (NBR) Type CS400 (1 required) Type CS403 (2 required) Type CS404 (2 required)	10A3802X022 10A3802X022 10A3802X022
28*	O-ring, Nitrile (NBR)	GE01439X012
36*	Valve Disk, Aluminum/Nitrile (NBR)	GE26497X012
37	Disk Clip, Stainless steel	GE33771X012
38	Control Spring, Music Wire or Stainless steel 3.5 to 5 in. w.c. / 9 to 12 mbar, Red 4.5 to 6.5 in. w.c. / 11 to 16 mbar, Purple 6 to 8 in. w.c. / 15 to 20 mbar, Gold 7.5 to 11 in. w.c. / 19 to 27 mbar, Blue 10 to 14 in. w.c. / 25 to 35 mbar, Unpainted 12 to 19 in. w.c. / 30 to 47 mbar, Green 18 to 28 in. w.c. / 45 to 69 mbar, Orange 1 to 2 psig / 69 to 138 mbar, Black 2 to 5.5 psig / 138 to 380 mbar, Yellow	GE30198X012 GE30195X012 GE30188X012 GE30189X012 GE30224X012 GE30196X012 GE30225X012 GE30190X012 GE30197X012

* Recommended spare part.

Key	Description	Part Number	Key	Description	Part Number
41	R.V. Spring, Stainless steel	GE30194X012	70	Globe Valve Body (continued)	
42	Spring Retainer, Aluminum	GE27296X012		Ductile Iron	
43	Spring Seat, Zinc-plated steel			1-1/4 NPT	GE26465X012
	Non-Relief	GE27327X012		1-1/2 NPT	GE26466X012
	Standard and Token Relief	GE28947X012		2 NPT	GE26467X012
44	Valve Stem, Aluminum			Rp 1-1/4	GE26469X012
	Standard Relief	GE27297X012		Rp 1-1/2	GE26470X012
	Token Relief	GE30895X012		Rp 2	GE26471X012
45	Diaphragm Screw Retainer for			NPS 2 / DN 50, CL125 / CL150 FF	GE26480X012
	Non-Relief, Zinc-plated steel	GE30887X012		NPS 2 / DN 50, PN 10/16	GE26481X012
47*	Adjustable Upper Seat			Steel	
	Token Relief, Aluminum	GE33332X012		1-1/4 NPT	GE26465X022
48	Token Restrictor Plate, Zinc-plated steel	GE28948X012		1-1/2 NPT	GE26466X022
51	Pusher Post, Aluminum			Rp 1-1/4	GE26469X022
	Non-Relief	ERAA00875A0		Rp 1-1/2	GE26470X022
	Standard and Token Relief	ERAA00876A0	71	Cap Screw, Steel (2 required)	GE32061X012
53	Pusher Post Pin, Stainless steel	GE29761X012	72	Pipe Plug, 1/4 NPT	
54	Roller Pin, Brass	GE27060X012		Steel	1C333528992
55*	Diaphragm Head Assembly, Steel/Nitrile (NBR)	GE31248X012		Stainless steel	1C3335X0012
55a	Diaphragm	-----	74	Blanking Plug, Aluminum	GE31255X012
55b	Diaphragm Head	-----	75*	Metric O-ring, Nitrile (NBR)	GF03442X012
56	Retaining Ring, Pusher Post Pin, Steel	GE33772X012	76	Half Flange, Plated steel (2 required)	GF01942X012
57	Slotted Spring Pin, Zinc-plated Steel	GE33668X012	77*	Metric O-ring, Nitrile (NBR)	GF03443X012
58	E-Ring (Standard Relief)	GE32969X012	80	Cap Screw, Steel (4 required)	GE38176X012
60	Closing Cap, Aluminum	GE29244X012	90	Nameplate	-----
62*	O-ring, Nitrile (NBR)	T10275X0012	91	Warning Label	-----
65	Adjusting Screw, Aluminum	GE27828X012	93	Information Label	-----
70	Globe Valve Body		94	Overlay Label	-----
	Gray Cast iron		95	Grommet, Nitrile (NBR)	GE35358X012
	1-1/4 NPT	GE26446X012	96	Slip Disk, Stainless steel	GG05787X012
	1-1/4 x 1-1/2 NPT	GE44458X012	100	Lockwire, Stainless steel	T14088T0012
	1-1/2 NPT	GE26448X012	101	Slotted Spring Pin, Plated steel	GE32724X012
	2 NPT	GE26459X012			
	Flange				
	NPS 2 / DN 50, CL125 FF	GE26460X012			

* Recommended spare part.

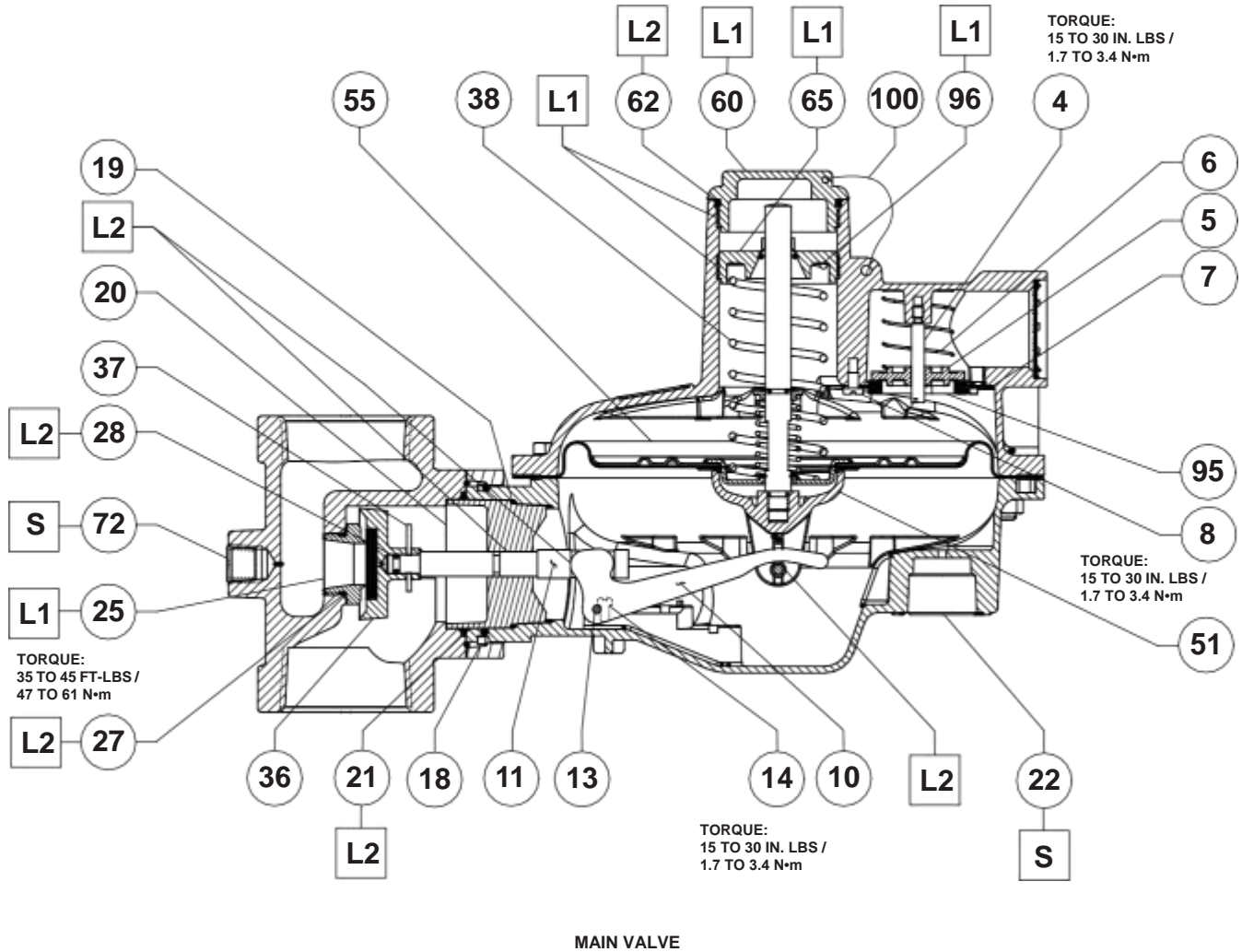

ERAA03738

- APPLY LUBRICANT (L) / SEALANT (S)⁽¹⁾:
- L1 = ANTI-SEIZE LUBRICANT
 - L2 = SILICONE GREASE
 - S = THREAD SEALANT

1. Lubricants and sealant must be selected such that they meet the temperature requirements.

Figure 8. CS400 Series Regulator Assemblies

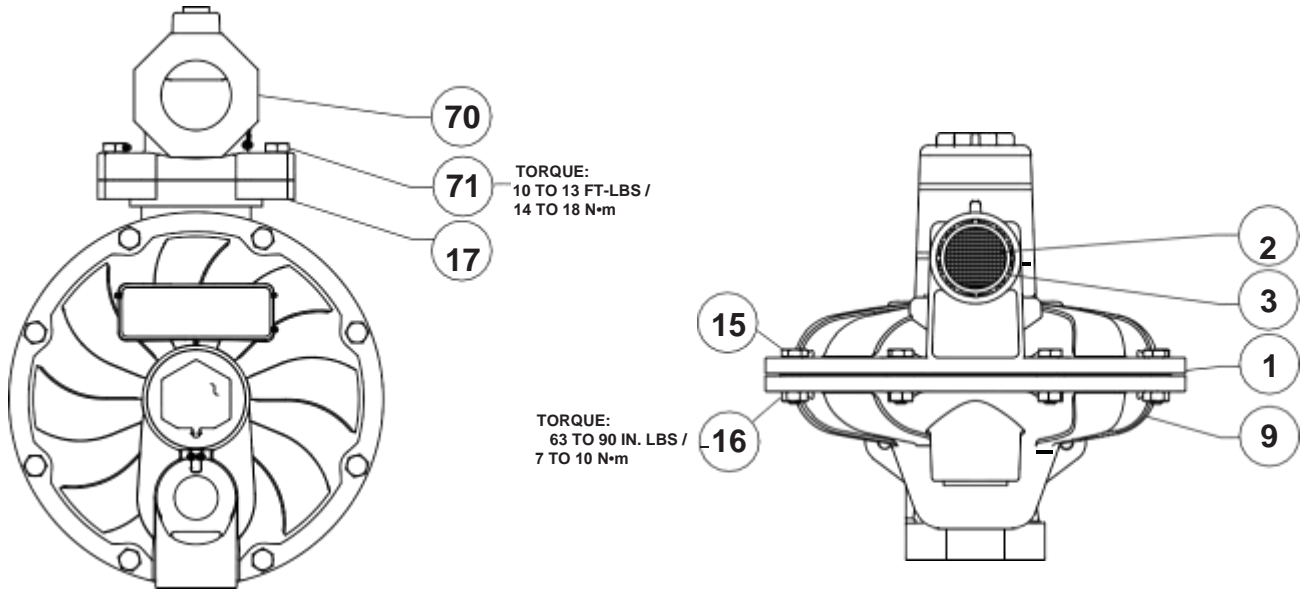

ERAA03738

Figure 8. CS400 Series Regulator Assemblies (continued)

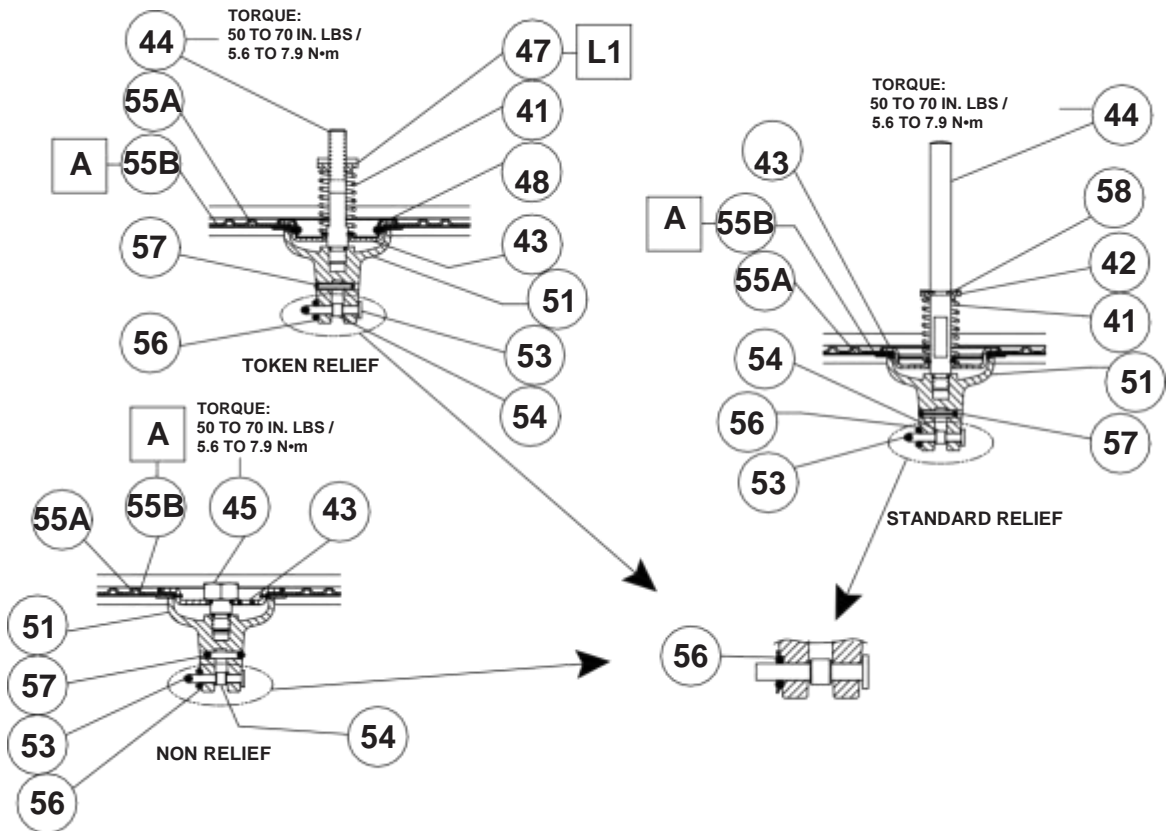

ERAA03738

□ APPLY LUBRICANT (L) / ADHESIVE (A)⁽¹⁾:
 L1 = ANTI-SEIZE LUBRICANT
 A = ADHESIVE

1. Lubricants and adhesive must be selected such that they meet the temperature requirements.

Figure 9. CS400 Series Diaphragm and Stem Assemblies

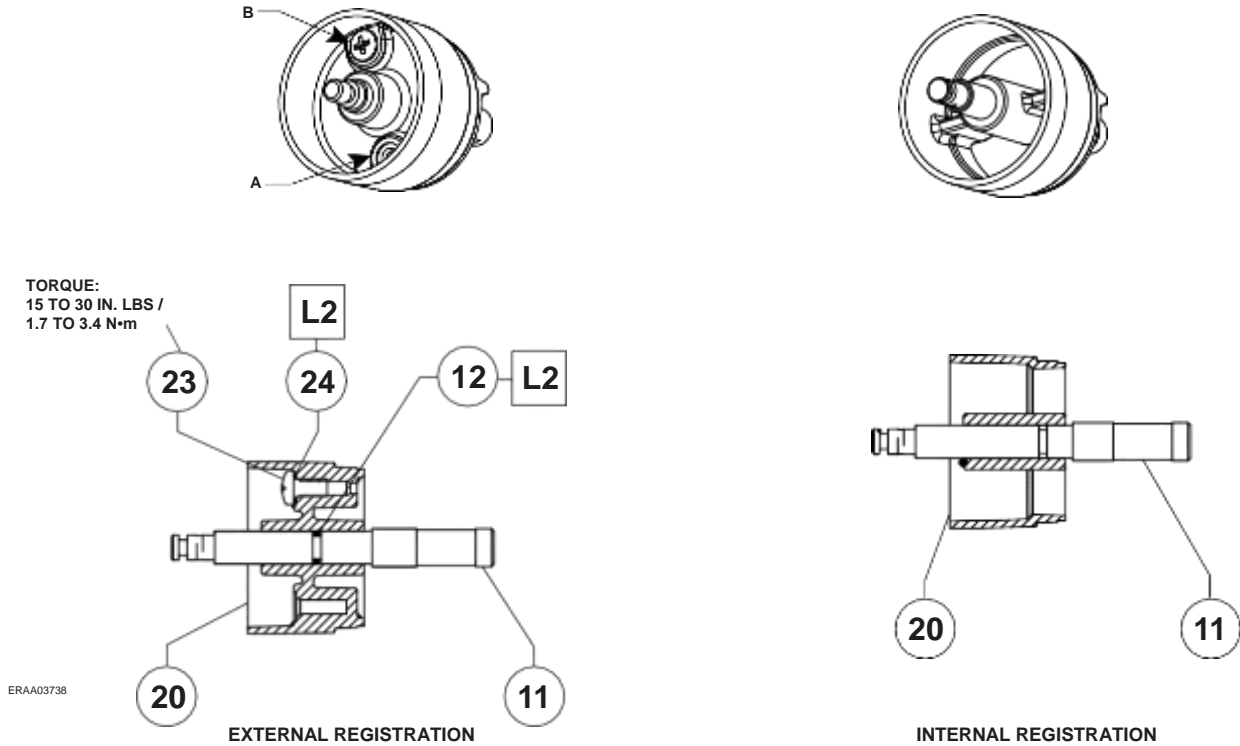
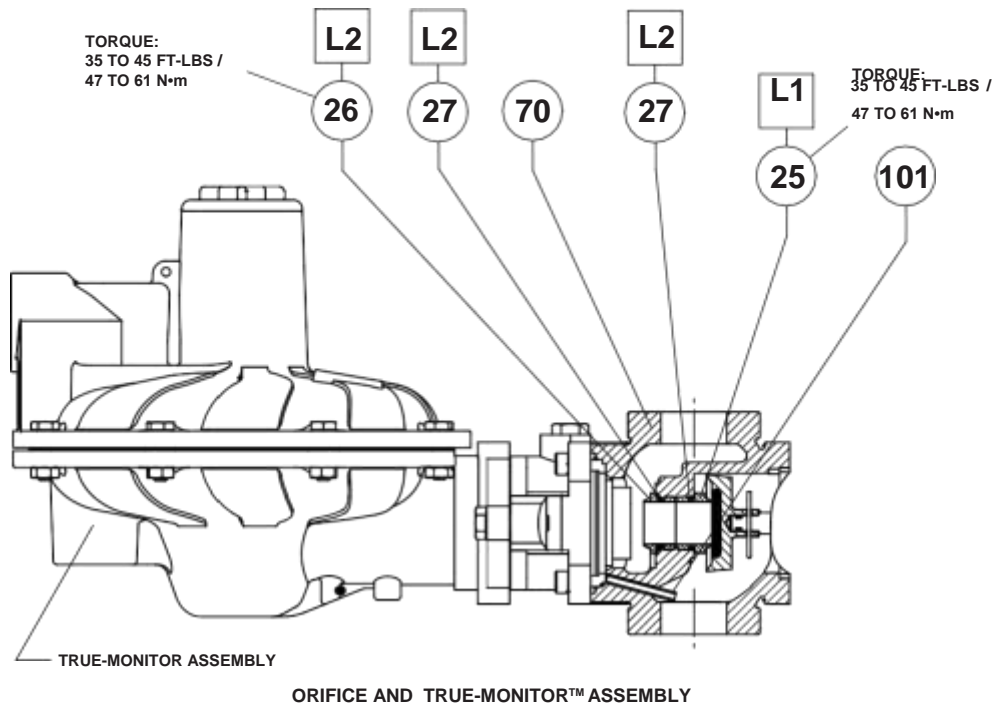

Figure 10. CS400 Series Registration Options



□ APPLY LUBRICANT (L)⁽¹⁾:
 L1 = ANTI-SEIZE LUBRICANT
 L2 = SILICONE GREASE

1. Lubricants must be selected such that they meet the temperature requirements.

Figure 11. CS400 Series Slam shut and Integral Monitor Modules

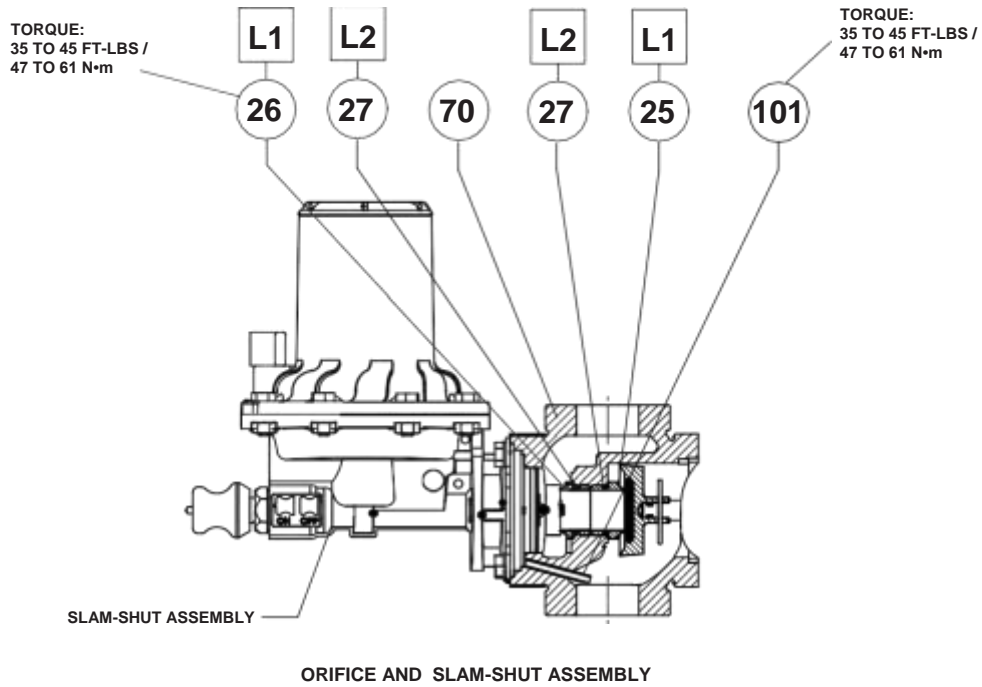
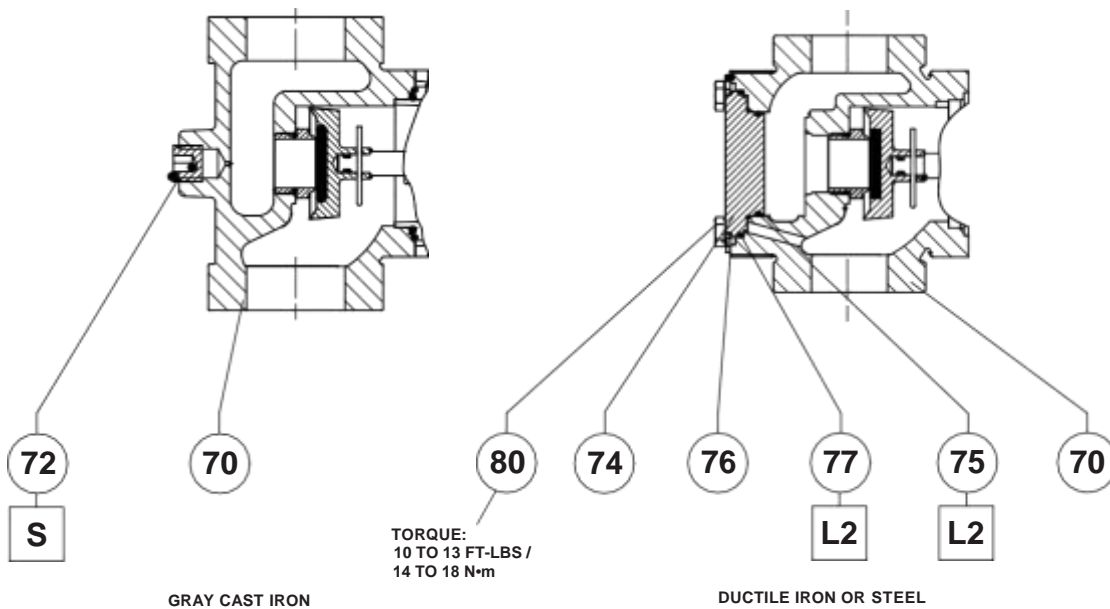



Figure 11. CS400 Series Slam shut and Integral Monitor Modules (continued)



- APPLY LUBRICANT (L) / SEALANT (S)⁽¹⁾:
 L1 = ANTI-SEIZE LUBRICANT
 L2 = SILICONE GREASE
 S = THREAD SEALANT

1. Lubricants and sealant must be selected such that they meet the temperature requirements.

Figure 12. Gray Cast Iron, Ductile Iron and Steel Body Configurations

บริษัท:	บริษัท เอดีดี เฟอร์เนส จำกัด Add Furnace Co.,Ltd.
ที่อยู่:(bangkok)	44 ซ.บรมราชชนนี 70 ถ.บรมราชชนนี ศาลาธรรมสพน์ ทวีวัฒนา กทม. 10170.
website:	https://www.add-furnace.com/
e-mail:	sales@add-furnace.com add028883472@gmail.com
โทร.(ออกแบบ):	08-08-170-170, 088-300-1122
โทร:	02-888-3472
Online Support:	Line ID: @add11 Wechat ID: add0883001122
แฟกซ์:	02-888-3258
 line ID:	@add11