

CS800 Series Commercial / Industrial Pressure Reducing Regulators

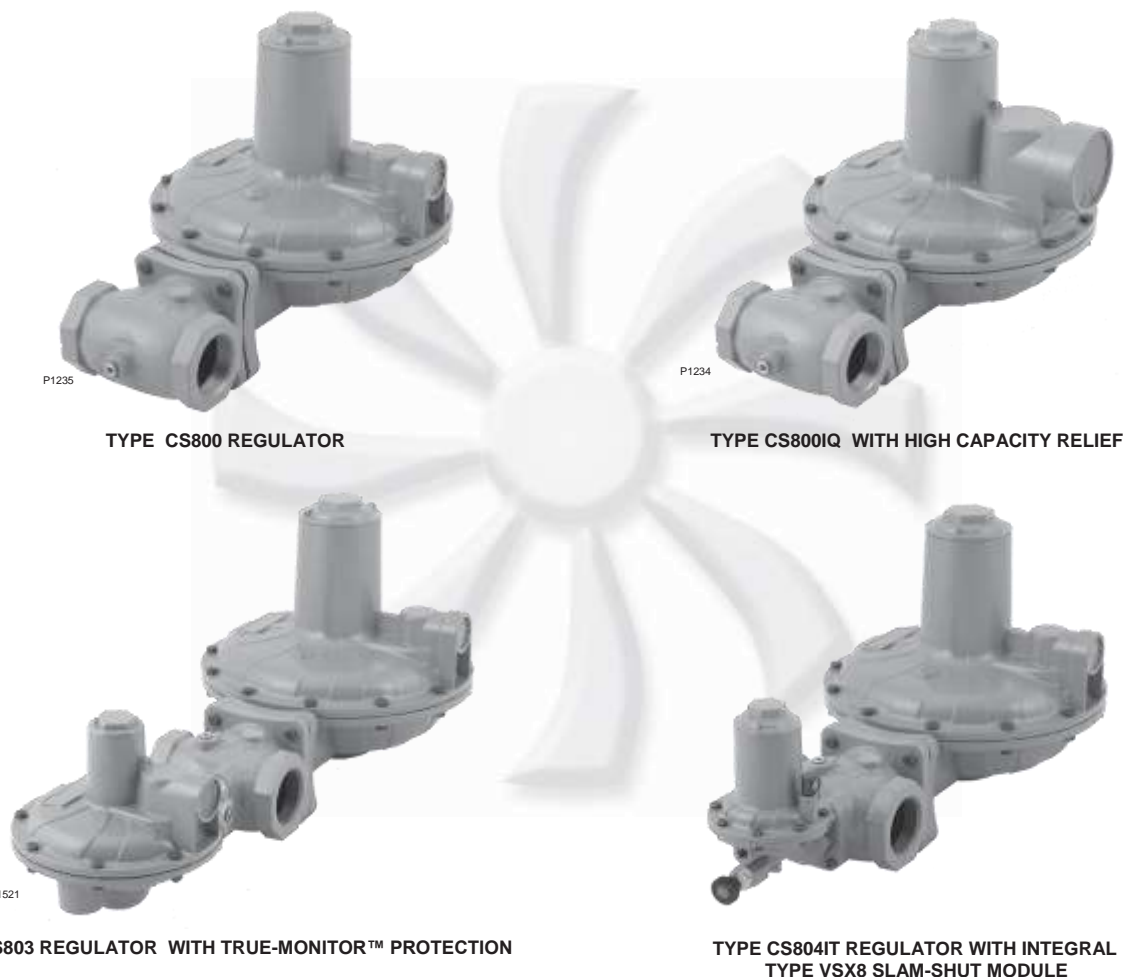

Figure 1. Typical CS800 Series Pressure Reducing Regulators

Table of Contents

Introduction	1
Specifications	2
Principle of Operation	3
Installation and Overpressure Protection	10
Startup	14
Adjustment	14
Shutdown	16
Maintenance and Inspection	16
Parts Ordering	20
Parts List	22

Introduction

Scope of the Manual

This Instruction Manual provides instructions for the installation, maintenance and parts ordering information of CS800 Series service regulators. Instructions and parts list for the Type TM600 Integral True-Monitor are found in Instruction Manual D103126X012. Instructions and parts list for the Type VSX8 Slam-shut are found in Instruction Manual D103127X012.

Specifications

The Specifications section lists the specifications for the CS800 Series regulators. The following information is stamped on the regulator at the factory: Type number, date of manufacture, spring range, orifice size, maximum inlet pressure, maximum operating outlet pressure and outlet pressure. Exceeding any of these limits may damage regulator parts.

Available Configurations

See Table 1

Body Sizes, Material, End Connections and Pressure Ratings⁽¹⁾

See Table 3

Maximum Inlet Pressures⁽¹⁾

Emergency: 175 psig / 12.1 bar

Operating: See Table 4

Maximum Outlet Pressure⁽¹⁾

Emergency

Regulator Casing: 15 psig / 1.0 bar

Integral Monitor Casing: 25 psig / 1.7 bar

Integral Slam-shut Casing: 87 psig / 6.0 bar

To avoid internal parts damage: 3 psig / 0.21 bar differential above outlet pressure setting

Operating Pressure Ranges⁽¹⁾

Regulator: See Table 5

Integral True-Monitor™: See Tables 8 and 9

Slam-shut Module: See Tables 10 to 11

Secondary Seat™ Protection Outlet Pressures

See Table 7

Spring Case Vent Connection

Internal Relief: 1 NPT

High Capacity Relief: 2-1/2 NPT

Internal Relief Performance

See Table 6

Token Relief Performance

Approximate Token Relief Start-to-Discharge:

See Table 6

Orifice Sizes, Flow Coefficients and IEC Sizing Coefficients

See Table 4

Pressure Registration

Internal or External

Temperature Capabilities⁽¹⁾⁽²⁾

-20 to 150°F / -30 to 66°C

According to European PED Directive that rates products to a minimum temperature of -4°F / -20°C and a maximum temperature of 140°F / 60°C:

-4 to 140°F / -20 to 60°C

Approximate Weight

With Threaded Body

Type CS800/CS820: 25 lbs / 11 kg

Type CS803/CS823: 34 lbs / 16 kg

Type CS804/CS824: 31 lbs / 16 kg

Type CS805/CS825: 26 lbs / 12 kg

Type CS806/CS826: 26 lbs / 12 kg

High-Pressure Types

For CS85x add 2 lbs / 1 kg to types listed above

With Flanged Body

Add 11 lbs / 5 kg to weights listed above

PED Conformity Statement and Information

Types CS800, CS804, CS820, CS824, CS850 and CS854 are in conformity with the Pressure Equipment Directive PED 2014/86/EU and are classified under Category I for units without a slam-shut and Category IV for units with a slam-shut. See Table 2.

For Types CS800, CS820 and CS850, equipment and pipeline situated on outlet side of the regulator are either

- not subject to the PED (PS ≤ 0.5 bar) or
- subject to (PS > 0.5 bar) in which case they should come under Category I maximum

PED Related Information

See Table 2

1. The pressure/temperature limits in this Instruction Manual and any applicable standard or code limitation should not be exceeded.

2. Product has passed Emerson Process Management Regulator Technologies, Inc. (Emerson) testing for lockup, relief start-to-discharge and reseal down to -40 degrees.

WARNING

Failure to follow these instructions or to properly install and maintain this equipment could result in an explosion and/or fire causing property damage and personal injury or death.

Fisher™ regulators must be installed, operated and maintained in accordance with federal, state and local codes, rules and regulations and Emerson instructions.

If the regulator vents gas or a leak develops in the system, service to the unit may be required. Failure to correct trouble could result in a hazardous condition.

Call a gas service person to service the unit. Only a qualified person must install or service the regulator.

Description

CS800 Series regulators are typically installed on industrial and commercial applications. See Table 1 for available configurations. Constructions with External Registration, e.g., Type CS800EN, require an external control line.

The CS800 Series offers multiple forms of overpressure protection including:

Internal Relief - Minimizes downstream pressure buildup by relieving gas through the diaphragm assembly and out the 1 NPT vent to atmosphere in the event of an overpressure situation.

High Capacity Relief - Provides an increase in relief performance over basic internal relief via a 2-1/2 NPT vent thereby offering a significant improvement in the level of overpressure protection to the downstream system in the event of an overpressure occurrence.

Table 1. Available Configurations

TYPE NUMBER				OPTION
C	S	8		
				OUTLET PRESSURE CONSTRUCTION
		0		Low Pressure Applications (Outlet Pressure: 3.5 to 30 in. w.c. / 9 to 75 mbar)
		2		Medium Pressure Applications (Outlet Pressure: 1 to 5.5 psig / 0.07 to 0.38 bar)
		5		High Pressure Applications (Outlet Pressure: 5 to 10 psig / 0.34 to 0.69 bar) ⁽¹⁾
				OVERPRESSURE PROTECTION MODULE
		0		Without Overpressure Protection Module
		3		With Integral True-Monitor Module ⁽⁴⁾
		4		With Slam-shut Module ⁽⁴⁾
		5		With Secondary Seat Protection
		6		With Secondary Seat Protection with controlled bleed to indicate Secondary Seat is functioning ⁽²⁾
				PRESSURE REGISTRATION
			I	Internal Registration
			E	External Registration ⁽³⁾
				RELIEF
			N	Non-Relieving
			R	Internal Relief
			Q	High-Capacity Relief
			T	Token Relief
			L	Low Flow Token Relief
			SC	Stabilizer Cartridge
Example: Type Number CS800IR: Type CS800 regulator without Overpressure Protection Module with Internal Pressure Registration and with Internal Relief. 1. High-pressure Construction is not available with True-Monitor Protection, Secondary Seat Protection or Relief. 2. Available only with Internal Relief or High-Capacity Relief Constructions. 3. Available only with Non-Relieving or Token Relief Constructions. 4. Reference Instruction Manual D103126X012 for information regarding the Type TM600 Integral True-Monitor or Instruction Manual D103127X012 for Type VSX8 safety Slam-shut module.				

Integral True-Monitor™ Protection - Provides a monitoring regulator integrally mounted on the inlet side of the valve body that assumes control of flow to the downstream system should the primary regulator cease to regulate flow.

Secondary Seat™ Protection - Provides a solution to the most common cause of regulators failing to shutoff by employing a secondary seating surface to provide shutoff in the event the primary orifice seating surface becomes damaged or blocked.

Slam-shut Protection - Discontinues gas service by shutting the gas off if there is an overpressure or underpressure condition.

Principle of Operation

Types CS800, CS820 and CS850 Base Regulators Operation

Refer to Figures 2 and 3. When downstream demand decreases, the pressure under the diaphragm increases. This pressure overcomes the regulator setting (which is set by the regulator control spring). Through the action of the pusher post assembly, lever and valve stem, the valve disk moves closer to the orifice and reduces gas flow. If demand downstream increases, pressure under the diaphragm decreases. Spring force pushes the pusher post assembly downward, the valve disk moves away from the orifice and the gas flow increases downstream as the regulator opens in response to the decreased pressure underneath the diaphragm.

The Type CS800IR regulator includes an internal relief valve for overpressure protection. If the downstream pressure

exceeds the regulator setting by 7 in. w.c. to 2.5 psig / 17 to 172 mbar (depending on the type number and main spring used), the relief valve opens and excess gas is vented through the stabilizer vent in the upper spring case. Units with standard internal relief valve have 1 NPT vent size, Figure 2, while units with high-capacity relief valve have 2-1/2 NPT vent size, Figure 3.

The Types CS800IT, CS800IL, CS800ET and CS800EL provide a low-capacity/token relief. Token relief provides relief from minor overpressure caused by nicks or dents on the orifice or by thermal expansion of gas in the downstream line. Token relief also provides a token or signal, in the form of odor, that an overpressure situation is occurring.

Stability Cartridge

The CS800 Series provides an optional stability cartridge as a solution to system instability. The stabilizer cartridge is used to increase system stability with no piping and minimal specification changes. This device is a compact assembly that is installed, without using any special tools, in the throat of a Type CS800 regulator. See Installation Sheet D104125X012.

Types CS803 and CS823 Integral True-Monitor Operation

Types CS803 and CS823 combine the operation of a conventional two-regulator wide-open monitor set into one body, see Figure 4. The Integral True-Monitor is installed on the inlet side of the body and serves to control downstream pressure in the situation where the primary regulator can no longer regulate downstream pressure.

Table 2. PED Information

TYPE	DESCRIPTION	BODY MATERIAL	PED CATEGORY	FLUID GROUP
CS800, CS820 and CS850	Base regulator	Ductile Iron and WCC Steel	I	Groups 1 and 2 according to 2014/86/EU, 1st and 2nd family gas according to EN 437 or other gases (compressed air, nitrogen). The gas must be non-corrosive, clean (filtration on inlet side necessary) and dry.
CS804, CS824 and CS854	Regulator with Slam-shut Module	Ductile Iron and WCC Steel	IV	
European EN Reference Standards			EN 334, EN 14382	

Table 3. Body Sizes, Materials, End Connections and Maximum Cold Working Pressure Ratings⁽⁵⁾

TYPE	BODY MATERIAL	END CONNECTION	BODY SIZE		PART NUMBER	FACE-TO-FACE DIMENSION		BODY INLET PRESSURE RATING	
			In.	DN		In.	mm	psig	bar
CS800, CS805, CS806, CS820, CS825, CS826 and CS850	Gray Cast Iron	NPT	1-1/4	----	GE25859X012	6.12	155	175	12.1
			1-1/2	----	GE26296X012	6.12	155		
			2 ⁽¹⁾	----	GE26300X012	6.12	155		
			2	----	ERAA02462A0	7.5	191		
		CL125 FF	2	50	GE26301X012	7.5	191		
			2	50	GE26303X012	10	254		
CS800 ⁽³⁾ , CS820 ⁽³⁾ , CS850 ⁽³⁾ , CS803, CS823, CS804, CS824 and CS854	Gray Cast Iron	NPT	2 ⁽²⁾	----	ERAA02437A0	6.12	155	175	12.1
	Ductile Iron	NPT	1-1/4 ⁽⁴⁾	----	GE26306X012	6.12	155	250	17.2
			1-1/2	----	ERAA02453A1	6.12	155		
			2	----	ERAA02437A1	6.12	155		
		Rp	2	----	ERAA02715A1	6.12	155		
		CL125 FF / CL150 FF	2	50	GE48292X012	7.5 ⁽⁴⁾	191 ⁽⁴⁾		
			2	50	ERAA02711A1	10	254		
			2	50	ERAA02718A1	10.5	267		
	PN 10/16	2	50	GE48296X012	7.5 ⁽⁴⁾	191 ⁽⁴⁾	232	16	
		2	50	ERAA02719A1	10	254			
		WCC Steel	NPT	1-1/4 ⁽⁴⁾	----	GE26306X022			6.12
	1-1/2			----	ERAA02453A2	6.12	155		
	2			----	ERAA02437A2	6.12	155		
	Rp		2	----	ERAA02715A2	6.12	155		
	CL150 RF		2	50	ERAA02720A2	10	254		
	PN 10/16	2	50	ERAA02719A2	10	254	232	16	

1. Standard on Types CS800, CS820 and CS850.

2. Standard on Types CS803, CS804, CS823, CS824 and CS854.

3. If a ductile iron or steel body material is selected without an Integral True-Monitor™ or Slam-shut Overpressure Protection (OPP) device, the port located at the bottom of the body will receive an aluminum plug.

4. Not available on Types CS804, CS824 and CS854.

5. The pressure/temperature limits in this Instruction Manual or any applicable standard or code limitation should not be exceeded.

Table 4. Inlet Pressure Ratings and Flow and Sizing Coefficients

ORIFICE SIZE		MAXIMUM OPERATING INLET PRESSURE TO OBTAIN OPTIMUM PERFORMANCE				MAXIMUM EMERGENCY INLET PRESSURE		WIDE-OPEN FLOW COEFFICIENTS			IEC SIZING COEFFICIENTS		
		psig Setpoints		In. w.c. Setpoints									
In.	mm	psig	bar	psig	bar	psig	bar	C _g	C _v	C _i	X _T	F _L	F _D
1/4 ⁽¹⁾	6.4 ⁽¹⁾	125	8.6	125	8.6	175	12.1	50	2.1	24.6	0.38	0.89	0.99
3/8	9.5	125	8.6	125	8.6			110	3.8	29.5	0.55		0.90
1/2	13	100	6.9	100	6.9			210	7.2	29.5	0.55		0.93
5/8	16	80	6.5	60	4.1			320	10.1	31.8	0.64		0.88
3/4	19	80	6.5	60	4.1			450	13.3	34	0.73		0.84
7/8	22	60	4.1	50	3.4			600	16.7	36	0.82		0.81
1 ⁽¹⁾	25 ⁽¹⁾	30	2.1	25	1.7			765	20.1	38.1	0.92		0.77
1-3/8 ⁽¹⁾⁽²⁾	35 ⁽¹⁾⁽²⁾	15	1.0	15	1.0			1125	29.8	37.7	0.90		0.76

1. Not available on the Types CS805, CS806, CS825 and CS826.

2. Not available on the Types CS803 and CS823.

Table 5. Outlet Pressure Ranges

TYPE	OUTLET PRESSURE RANGE		COLOR CODE	PART NUMBER	SPRING WIRE DIAMETER		SPRING FREE LENGTH	
	In. w.c.	mbar			In.	mm	In.	mm
CS800, CS803, CS804, CS805 and CS806	3.5 to 6 ⁽¹⁾	9 to 15 ⁽¹⁾	Red	GE30337X012	0.15	3.8	6.8	173
	5.5 to 8.5	13 to 21	Black	GE30338X012	0.17	4.3	6.8	173
	5.5 to 8.5	13 to 21	Brown [Use with Low Inlet (LIN) Option]	GE49043X012	0.16	4.1	8.3	211
	8 to 12	20 to 30	Purple	GE30339X012	0.17	4.3	7.4	188
	10 to 16	25 to 40	White	GE30340X012	0.18	4.6	7.4	188
	14 to 30	35 to 75	Dark Green	GE30341X012	0.20	5.2	7.5	191
CS820, CS823, CS824, CS825 and CS826	1 to 2.5 psig	69 to 170	Dark Blue	GE30342X012	0.25	6.4	7.5	191
	1.5 to 3.5 psig	100 to 241	Orange	GE46922X012	0.26	6.6	7.1	180
	2.5 to 5.5 psig	170 to 380	Yellow	GE30343X012	0.29	7.5	6.7	170
CS850 and CS854	5 to 10 psig	345 to 690	Green with White Stripe	GE30344X012	0.39	9.9	7.6	192

1. In order to achieve the complete spring range listed, in some applications it may be required to re-orient the actuator/spring case to point downward to utilize the weight of the internal components.

Table 6. Approximate Internal Relief Valve Start-to-Discharge Pressure above Setpoint

CONTROL SPRING	SETPOINT		SET RANGE		INTERNAL RELIEF AND HIGH CAPACITY RELIEF				TOKEN RELIEF	
					Start-to-Discharge Pressure Range Above Setpoint		Low Start-to-Discharge Option ⁽¹⁾		Start-to-Discharge Pressure Range Above Setpoint	
	In. w.c.	mbar	In. w.c.	mbar	In. w.c.	mbar	In. w.c.	mbar	In. w.c.	mbar
GE30337X012	4	10	3.5 to 6	9 to 15	11 to 18	27 to 42	7 to 14	17 to 35	6 to 14	15 to 35
GE30338X012	7	17	5.5 to 8.5	13 to 21	11 to 18	27 to 42	7 to 14	17 to 35	6 to 14 25 to 35	15 to 35 62 to 87
GE49043X012 (LIN)	7	17	5.5 to 8.5	13 to 21	11 to 18	27 to 42	7 to 14	17 to 35	6 to 14 25 to 35	15 to 35 62 to 87
GE30339X012	11	27	8 to 12	20 to 30	11 to 18	27 to 42	7 to 14	17 to 35	6 to 14	15 to 35
GE30340X012	14	35	10 to 16	25 to 40	11 to 18	27 to 42	7 to 14	17 to 35	6 to 14 25 to 35	15 to 35 62 to 87
GE30341X012	1 psig	69	14 to 30	35 to 75	7 in. w.c. to 1 psig	17 to 69	----	----	8 to 16	20 to 40
GE30342X012	2 psig	138	1 to 2.5 psig	70 to 170	7 in. w.c. to 2 psig	17 to 138	----	----	7 in. w.c. to 1 psig	17 to 69
GE46922X012	3 psig	207	1.5 to 3.5 psig	100 to 240	7 in. w.c. to 2 psig	17 to 138	----	----	0.5 to 1.5 psig	35 to 100
GE30343X012	5 psig	345	2.5 to 5.5 psig	170 to 380	7 in. w.c. to 2.5 psig	17 to 170	----	----	1 to 2 psig	69 to 138

1. Low start-to-discharge option is only available on the main control spring ranges up to 10 to 16 in. w.c. / 25 to 40 mbar.

Table 7. Secondary Seat™ Protection Outlet Pressures

CONTROL SPRING		SPRING RANGE		SETPOINT		TYPES CS805 AND CS825				TYPES CS806 AND CS826			
						Secondary Seat Shut-off Pressure ⁽²⁾				Downstream Build-up Pressure ⁽¹⁾⁽²⁾⁽³⁾			
						Orifice Size, In. / mm				Orifice Size, In. / mm			
Color	Part Number	In. w.c.	mbar	In. w.c.	mbar	3/8 / 9.5	5/8 / 16	3/8 / 9.5	5/8 / 16	In. w.c.	mbar	In. w.c.	mbar
Black	GE30338X012	5.5 to 8.5	13 to 21	7	17	11	27	12	30	25	62	23	57
Brown (LIN)	GE49043X012	5.5 to 8.5	13 to 21	7	17	11	27	12	30	25	62	23	57
White	GE30340X012	10 to 16	25 to 40	14	35	19	47	20	50	36	89	33	81
Dark Green	GE30341X012	14 to 30	35 to 75	1 psig	69	1.2 psig	83	1.3 psig	90	2.1 psig	0.14 bar	2 psig	0.14 bar
Dark Blue	GE30342X012	1 to 2.5 psig	69 mbar to 0.17 bar	2 psig	0.14 bar	2.6 psig	0.17 bar	2.6 psig	0.18 bar	3.8 psig	0.26 bar	3.7 psig	0.26 bar
Yellow	GE30343X012	2.5 to 5.5 psig	0.17 to 0.38 bar	5 psig	0.34 bar	6.3 psig	0.43 bar	6.3 psig	0.43 bar	7.4 psig	0.51 bar	8.2 psig	0.56 bar

1. Downstream pressure buildup with Secondary Seat fixed bleed in operation and regulator relief valve relieving to atmosphere.
 2. Outlet pressure values listed are at maximum operating inlet pressure rating per orifice. See Table 4.
 3. If the outlet pressure rises above setpoint exceeds 3 psig / 207 mbar, inspect internal parts and replace if damaged.

Table 8. Primary Regulator and Integral True-Monitor™ Outlet Pressure Ranges without Token Relief

Type	PRIMARY REGULATOR					INTEGRAL TRUE-MONITOR						
	Typical Setpoint		Spring Part Number	Spring Range		Spring Color	Setpoint		Spring Part Number	Spring Range		Spring Color
	In. w.c.	mbar		In. w.c.	mbar		In. w.c.	mbar		In. w.c.	mbar	
CS803IN and CS803EN	4	10	GE30337X012	3.5 to 6	9 to 15	Red	14	35	GE30189X012	12 to 21	30 to 52	Blue
							21	52	GE30196X012	18 to 30	45 to 75	Green
							1 psig	69	GE30225X012	26 to 40	65 to 99	Orange
	7	17	GE30338X012	5.5 to 8.5	13 to 21	Black	14	35	GE30189X012	12 to 21	30 to 52	Blue
							21	52	GE30196X012	18 to 30	45 to 75	Green
							1 psig	69	GE30225X012	26 to 40	65 to 99	Orange
	7	17	GE49043X012	5.5 to 8.5	13 to 21	Brown (LIN)	14	35	GE30189X012	12 to 21	30 to 52	Blue
							21	52	GE30196X012	18 to 30	45 to 75	Green
							1 psig	69	GE30225X012	26 to 40	65 to 99	Orange
	11	27	GE30339X012	8 to 12	20 to 30	Purple	21	52	GE30196X012	18 to 30	45 to 75	Green
							1 psig	69	GE30225X012	26 to 40	65 to 99	Orange
							1.5 psig	103	GE30190X012	1.4 to 2.9 psig	97 to 200	Black
	14	35	GE30340X012	10 to 16	25 to 40	White	21	52	GE30196X012	18 to 30	45 to 75	Green
							1 psig	69	GE30225X012	26 to 40	65 to 99	Orange
							1.5 psig	103	GE30190X012	1.4 to 2.9 psig	97 to 200	Black
	1 psig	69	GE30341X012	14 to 30	35 to 75	Dark Green	1.5 psig	103	GE30190X012	1.4 to 2.9 psig	97 to 200	Black
							2 psig	138	GE30190X012	1.4 to 2.9 psig	97 to 200	Black
							3.5 psig	241	GE35081X012	2.6 to 3.7 psig	179 to 255	Purple
CS823IN and CS823EN	2 psig	138	GE30342X012	1 to 2.5 psig	69 to 170	Dark Blue	2.5 psig	172	GE30190X012	1.4 to 2.9 psig	97 to 200	Black
							3 psig	207	GE35081X012	2.6 to 3.7 psig	179 to 255	Purple
							5 psig	345	GE30192X012	3.6 to 6 psig	248 to 414	Dark Blue
	3 psig	207	GE46922X012	1.5 to 3.5 psig	100 to 241	Orange	3.5	241	GE35081X012	2.6 to 3.7 psig	179 to 255	Purple
							4	276	GE30192X012	3.6 to 6 psig	248 to 414	Dark Blue
							6	414	GE33121X012	4 to 7.5	276 to 517	Red
	5 psig	345	GE30343X012	2.5 to 5.5 psig	170 to 380	Yellow	6	414	GE33121X012	4 to 7.5	276 to 517	Red
							7	483	GE33121X012	4 to 7.5	276 to 517	Red
							7.5	517	GE33121X012	4 to 7.5	276 to 517	Red



Table 9. Primary Regulator and Integral True-Monitor™ Outlet Pressure Ranges with Token Relief

PRIMARY REGULATOR						INTEGRAL TRUE-MONITOR						
Type	Setpoint		Spring Part Number	Spring Pressure Range		Spring Color	Setpoint		Spring Part Number	Spring Pressure Range		Spring Color
	In. w.c.	mbar		In. w.c.	mbar		In. w.c.	mbar		In. w.c.	mbar	
CS803IT, CS803IL, CS803ET and CS803EL	4	10	GE30337X012	3.5 to 6	9 to 15	Red	21	52	GE30196X012	18 to 30	45 to 75	Green
							1 psig	69	GE30225X012	26 to 40	65 to 99	Orange
	7	17	GE30338X012	5.5 to 8.5	13 to 21	Black	21	52	GE30196X012	18 to 30	45 to 75	Green
							1 psig	69	GE30225X012	26 to 40	65 to 99	Orange
	7	17	GE49043X012	5.5 to 8.5	13 to 21	Brown (LIN)	21	52	GE30196X012	18 to 30	45 to 75	Green
							1 psig	69	GE30225X012	26 to 40	65 to 99	Orange
	11	27	GE30339X012	8 to 12	20 to 30	Purple	1 psig	69	GE30225X012	26 to 40	65 to 99	Orange
							1.5 psig	103	GE30190X012	1.4 to 2.9 psig	97 to 200	Black
	14	35	GE30340X012	10 to 16	25 to 40	White	1 psig	69	GE30225X012	26 to 40	65 to 99	Orange
							1.5 psig	103	GE30190X012	1.4 to 2.9 psig	97 to 200	Black
	1 psig	69	GE30341X012	14 to 30	35 to 75	Dark Green	2 psig	138	GE30190X012	1.4 to 2.9 psig	97 to 200	Black
							3 psig	207	GE35081X012	2.6 to 3.7 psig	179 to 255	Purple
CS823IT, CS823IL, CS823ET and CS823EL	2 psig	138	GE30342X012	1 to 2.5	69 to 170	Dark Blue	3 psig	207	GE35081X012	2.6 to 3.7 psig	179 to 255	Purple
							4 psig	276	GE30192X012	3.6 to 6 psig	248 to 414	Dark Blue
	3 psig	207	GE46922X012	1.5 to 3.5	100 to 241	Orange	5 psig	345	GE30192X012	3.6 to 6 psig	248 to 414	Dark Blue
							6 psig	414	GE33121X012	5.1 to 7.5 psig	352 to 517	Red
	5 psig	345	GE30343X012	2.5 to 5.5	170 to 380	Yellow	7 psig	483	GE33121X012	5.1 to 7.5 psig	352 to 517	Red
							7.5 psig	517	GE33121X012	5.1 to 7.5 psig	352 to 517	Red

Table 10. Regulator and Slam-shut Overpressure Shutoff (OPSO) Pressure Ranges

REGULATOR					SLAM-SHUT DEVICE				
Type	Factory Setpoint		Spring Range		Factory Setpoint ⁽¹⁾		Spring Range ⁽²⁾		Spring Part Number and Color
	In. w.c.	mbar	In. w.c.	mbar	In. w.c.	mbar	In. w.c.	mbar	
CS804	4	10	3.5 to 6	9 to 15	19	47	12 to 25	30 to 60	GF02168X012 / Brown
	7	17	5.5 to 8.5	14 to 21	22	55			
	7 (optional)	17 (optional)	5.5 to 8.5	14 to 21	25	62	16 to 44	40 to 110	GF02169X012 / Red
	11	27	8 to 12	20 to 30					
	14	35	10 to 16	25 to 40	30	75	24 to 78	60 to 190	GF02170X012 / Orange
	14 (optional)	35 (optional)	10 to 16	25 to 40	2 psig	138	1.4 to 4.1 psig	97 to 283	GF02171X012 / Pink
	1 psig	69	14 to 30	35 to 75	2 psig	138			
CS824	2 psig	138	1 to 2.5 psig	69 to 170	3.5 psig	241	2 to 7.3 psig	138 to 503	GF02172X012 / Green
	3 psig	207	1.5 to 3.5 psig	100 to 241	5 psig	345			
	5 psig	345	2.5 to 5.5 psig	170 to 380	7 psig	483	3.2 to 8.5 psig	221 to 586	GF02173X012 / Silver
CS854	7 psig	483	5 to 10 psig	345 to 690	9 psig	621	5.8 to 13 psig	400 to 896	GF04353X012 / Yellow

1. For units equipped with Token Relief, if Non-Factory Slam-shut OPSO setpoints are specified, they must be higher than the Token Relief Start-to-Discharge values provided in Table 6.
2. If Non-Factory OPSO setpoints are specified, the allowable OPSO setpoint cannot exceed the maximum of 3 psig / 207 mbar above the regulator setpoint in order to ensure no internal parts damage from overpressure.

Table 11. Regulator and Slam-shut Underpressure Shutoff (UPS0) Pressure and Overpressure Shutoff (OPSO) Ranges

REGULATOR					SLAM-SHUT DEVICE									
					Under Pressure Shut-off (UPS0)					Over Pressure Shut-off (OPSO)				
Type	Factory Setpoint		Spring Range		Factory Setpoint ⁽¹⁾		Spring Range		Spring Part Number and Color	Factory Setpoint ⁽²⁾		Spring Range Over UPS0 Setpoint ⁽³⁾		Spring Part Number and Color
	In. w.c.	mbar	In. w.c.	mbar	In. w.c.	mbar	In. w.c.	mbar		In. w.c.	mbar	In. w.c.	mbar	
CS804	7	17	5.5 to 8.5	14 to 21	3	7	2 to 12	5 to 30	T14168T0012 / White	22	55	17 to 28	42 to 69	GF02168X012 / Brown
	11	27	8 to 12	20 to 30	6	15								
	14	35	10 to 16	25 to 40	9	22								
	1 psig	69	14 to 30	35 to 75	0.5 psig	35	0.36 to 2.3 psig	25 to 160	T14170T0012 / Silver	2 psig	138	1.3 to 3.1 psig	90 to 214	GF02170X012 / Orange
CS824	2 psig	138	1 to 2.5 psig	69 to 170	1 psig	69	0.36 to 2.3 psig	25 to 160	T14170T0012 / Silver	3.5 psig	241	1.3 to 3.1 psig	90 to 214	GF02170X012 / Orange
	3 psig	207	1.5 to 3.5 psig	100 to 241	1.75 psig	121	1.5 to 7.3 psig	100 to 500	FA142869X12 / Orange Stripe	5 psig	345	2.7 to 5.5 psig	186 to 379	GF02171X012 / Pink
	5 psig	345	2.5 to 5.5 psig	170 to 380	3 psig	207								
CS854	7 psig	483	5 to 10 psig	345 to 690	3.5 psig	241	1.5 to 7.3 psig	100 to 500	FA142869X12 / Orange Stripe	9 psig	621	2.7 to 5.5 psig	186 to 379	GF02171X012 / Pink

1. If Non-Factory UPS0 setpoints are specified, a minimum differential of 4 in. w.c. / 10 mbar between UPS0 setpoint and regulator setpoint must be maintained in order to ensure a secure latch of the Slam-shut.
 2. For units equipped with Token Relief, if Non-Factory Slam-shut OPSO setpoints are specified, they must be higher than the Token Relief Start-to-Discharge values provided in Table 6.
 3. If Non-Factory OPSO setpoints are specified, the allowable OPSO setpoint cannot exceed the maximum of 3 psig / 207 mbar above the regulator setpoint in order to ensure no internal parts damage from overpressure.

During normal operation the True-Monitor™ is in a wide open state as its setpoint is set higher than the primary regulator. See Tables 8 and 9 for guidance regarding the setpoints of the regulator and associated Integral Monitor sets. If the downstream pressure should rise to the setpoint of the True-Monitor due to loss of pressure control by the primary regulator, the monitor will assume control and regulate flow to the downstream system. If a token relief is present, the token relief will relieve a small amount of gas to the atmosphere as an indication that the Integral Monitor is controlling the downstream pressure.

Either internal or external downstream pressure registration is available. External pressure registration requires a downstream sensing line. See the Type TM600 Integral True-Monitor Instruction Manual (D103126X012) for additional details of operation.

Types CS804, CS824 and CS854 Slam-shut Operation

The Type VSX8 Slam-shut module on the CS804 Series regulators is a fast acting shutoff device that provides overpressure (OPSO) or overpressure and underpressure (OPSO/UPS0) protection by completely shutting off the flow of gas to the downstream system. See Tables 10 and 11 for guidance regarding the typical setpoint of the regulator and associated OPSO and UPS0 sets. The Type VSX8's actions are independent of the CS804 Series regulator and of variations to the inlet pressure. The Type VSX8 provides the option of internal or external downstream pressure registration. External registration requires a downstream

sensing line. See Figure 11 for guidance regarding installation of the downstream control line.

The Type VSX8 shutoff disk is normally in the open (reset) position, see Figure 5. If the downstream pressure below the slam-shut diaphragm increases (or decreases) until it reaches the slam-shut setpoint, this diaphragm moves upward (or downward) to release the trip mechanism which allows the spring force on the stem to push the disk against the seat, shutting off all gas flow. To reset the slam-shut after gas has been shutoff; refer to Type VSX8 Instruction Manual (D103127X012) for additional details.

! WARNING

In order for the Underpressure Shutoff (UPS0) of any slam-shut to be triggered, the downstream pipe pressure must drop below the UPS0 setpoint. In the case of a downstream line break, numerous factors can prevent the downstream pipe pressure from decreasing below the slam-shut UPS0 setpoint. These factors include the distance of pipe to the break, the diameter of the pipe, size of the break and the number of restrictions, such as valves, elbows and bends, downstream of the regulator and/or slam-shut device. Due to these factors additional protections should be installed to stop flow in the event of a line break.

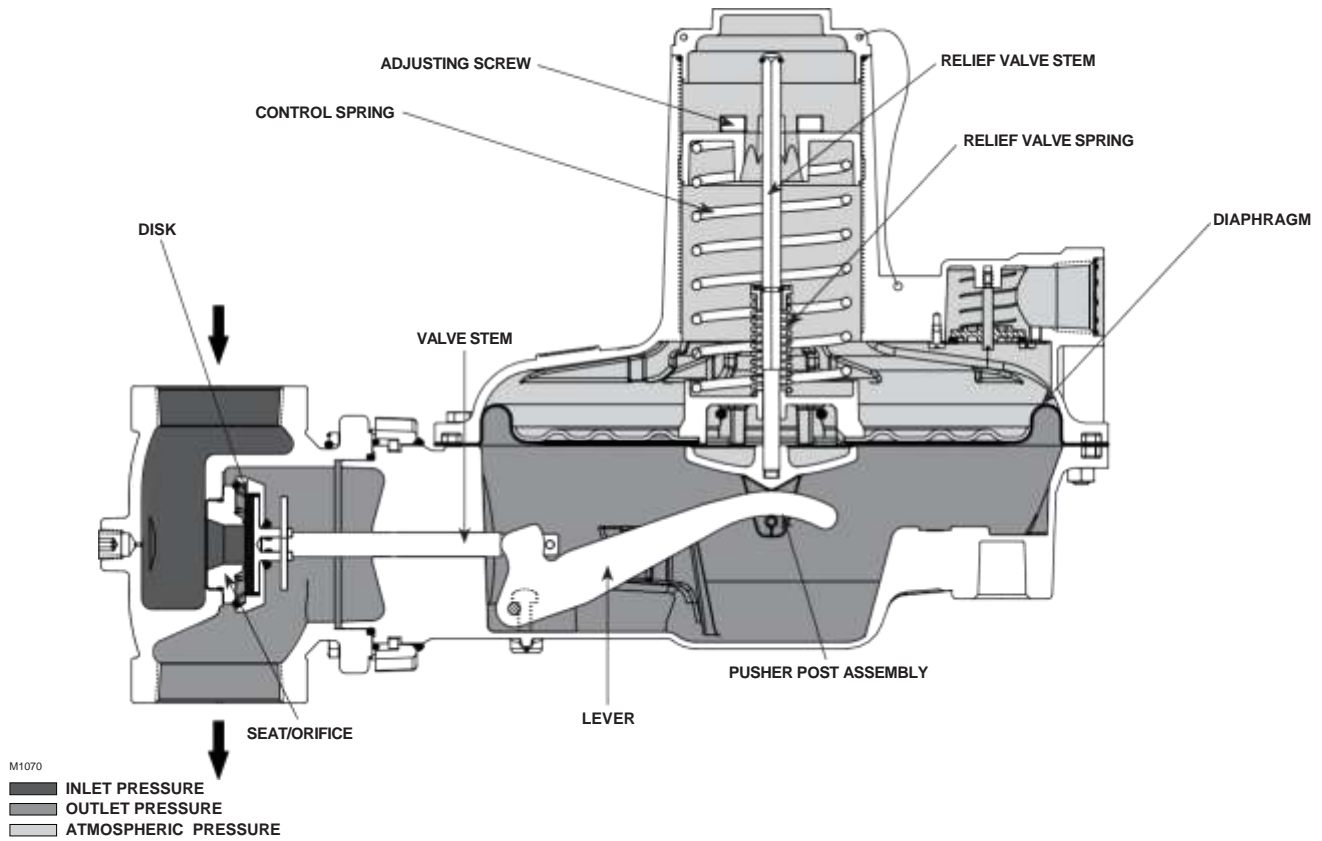

Figure 2. Type CS800IR Internally Registered Regulator with Internal Relief Operational Schematic

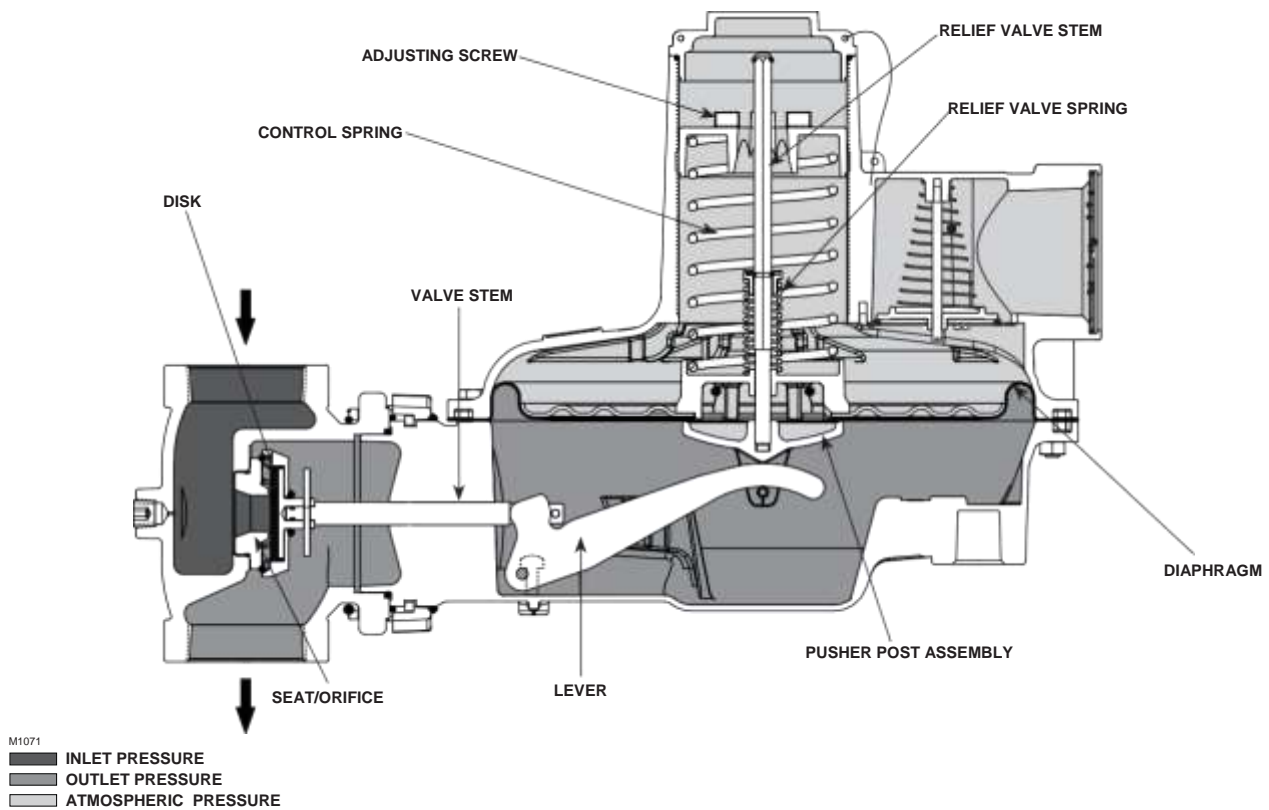

Figure 3. Type CS800IQ Internally Registered Regulator with High Capacity Relief Operational Schematic

If the slam-shut device trips due to a lever disconnect failure of the main regulator, it is recommended that you check downstream equipment for damage prior to re-setting the slam-shut.

Types CS805 and CS825 with Secondary Seat™ Protection

CAUTION

Types CS805 and CS825 regulators do not have any means to alert when the Secondary Seat operates at lockup. Therefore, it is recommended that Internal relief or high-capacity relief are also selected or the addition of some other method of overpressure protection be added in the downstream system as discussed in the Overpressure Protection section.

Refer to Figure 6. The CS805 Series provides Secondary Seat Protection. As downstream demand decreases and downstream pressure rises to the regulator pressure lock-up value, the regulator will lock up. If, however, damage has occurred to the primary disk or orifice's seating surface (seat) or debris has become lodged between the primary disk and seat, the outlet pressure will continue to rise. This additional pressure causes the disk to apply additional force to the primary seat, which causes the Secondary Seat to move toward the secondary disk/sealing surface. If downstream demand decreases to zero, then the Secondary Seat will contact the sealing surface to provide lockup. Refer to Table 7 for approximate lock-up values provided by the Secondary Seat.

Types CS806 and CS826 Secondary Seat Protection with Bleed

When the Secondary Seat is providing lockup, the CS806 Series provides small bleed to the downstream system as an indication that the Secondary Seat is providing lockup. In the event that the primary seat and disk cannot provide lockup, the Secondary Seat will move into contact with a metal disk with a small drilled hole. This metal-to-metal interface and bleed hole will allow a small amount of gas to bleed downstream thereby increasing outlet pressure until the Internal relief valve begins to discharge gas to the atmosphere. The odor of this discharged gas provides an indication that the regulator is relying on the Secondary Seat for overpressure protection. See Table 7 for the Downstream Pressure Buildup of the Internal relief acting in conjunction with the Type CS806 Secondary Seat Assembly.

Secondary Seat Protection Limitations

CAUTION

Overpressure conditions can occur in the downstream piping when the Secondary Seat Protection is installed. The Secondary Seat Protection serves only as a backup to the

primary seat for lockup. Refer to the sections on Overpressure Protection and Maintenance.

Secondary Seat Protection does not provide additional overpressure protection in the event the secondary seat or disk is damaged by debris or contamination in the pipeline or from conditions that would cause the regulator to go wide-open.

Installation and Overpressure Protection

! WARNING

Personal injury or system damage may result if this regulator is installed, without appropriate overpressure protection, where service conditions could exceed the limits given on the regulator nameplate.

Regulator installations should be adequately protected from physical damage.

All vents should be kept open to permit free flow of gas to the atmosphere. Protect openings against entrance of rain, snow, insects or any other foreign material that may plug the vent or vent line. For outdoor installations, point the spring case vent downward to allow condensate to drain (see Figure 8). This minimizes the possibility of freezing and of water or other foreign materials entering the vent and interfering with proper operation.

Under enclosed conditions or indoors, escaping gas may accumulate and be an explosion hazard. In these cases, the vent should be piped away from the regulator to the outdoors. See Vent Line Installation section for the recommended venting practices.

CAUTION

The CS800 Series regulators have an outlet pressure rating lower than their inlet pressure rating. If actual inlet pressure can exceed the outlet pressure rating, outlet overpressure protection is necessary. However, overpressuring any portion of the regulators beyond the limits in the Specifications section and referenced tables may cause leakage, damage to regulator parts or personal injury due to bursting of pressure-containing parts.

Some type of external overpressure protection should be provided if inlet pressure will be high enough to damage downstream equipment. Common methods of external overpressure protection include relief valves, monitoring regulators, shut-off devices and series regulation.

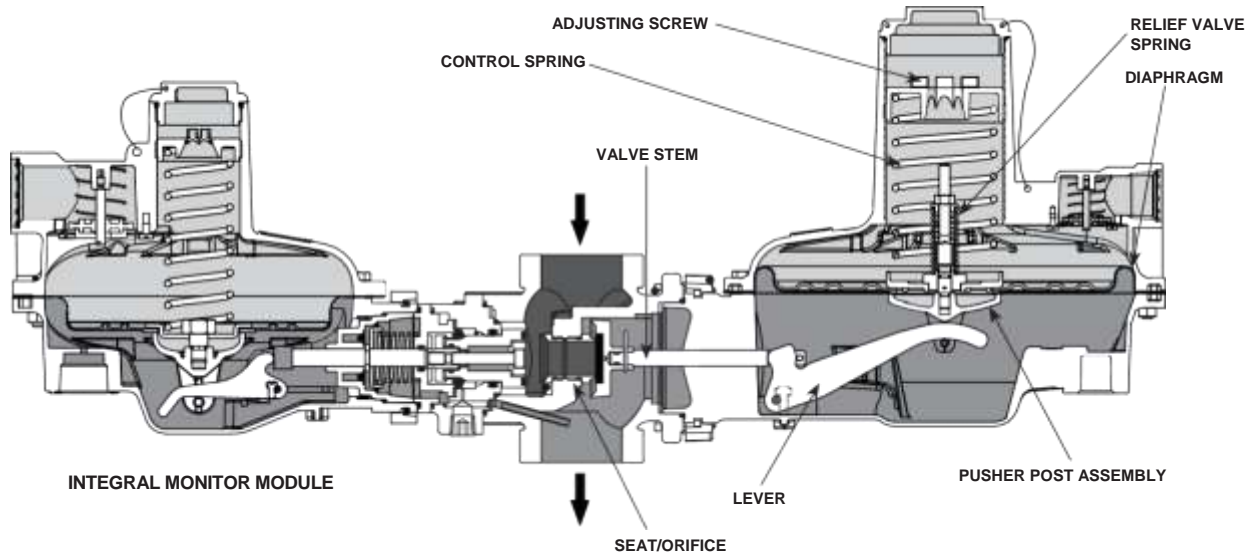

M1074

■ INLET PRESSURE
 ■ OUTLET PRESSURE
 ■ ATMOSPHERIC PRESSURE

Figure 4. Type CS803IT Internally Registered Primary Regulator with Internally Registered Integral Monitor Operational Schematic

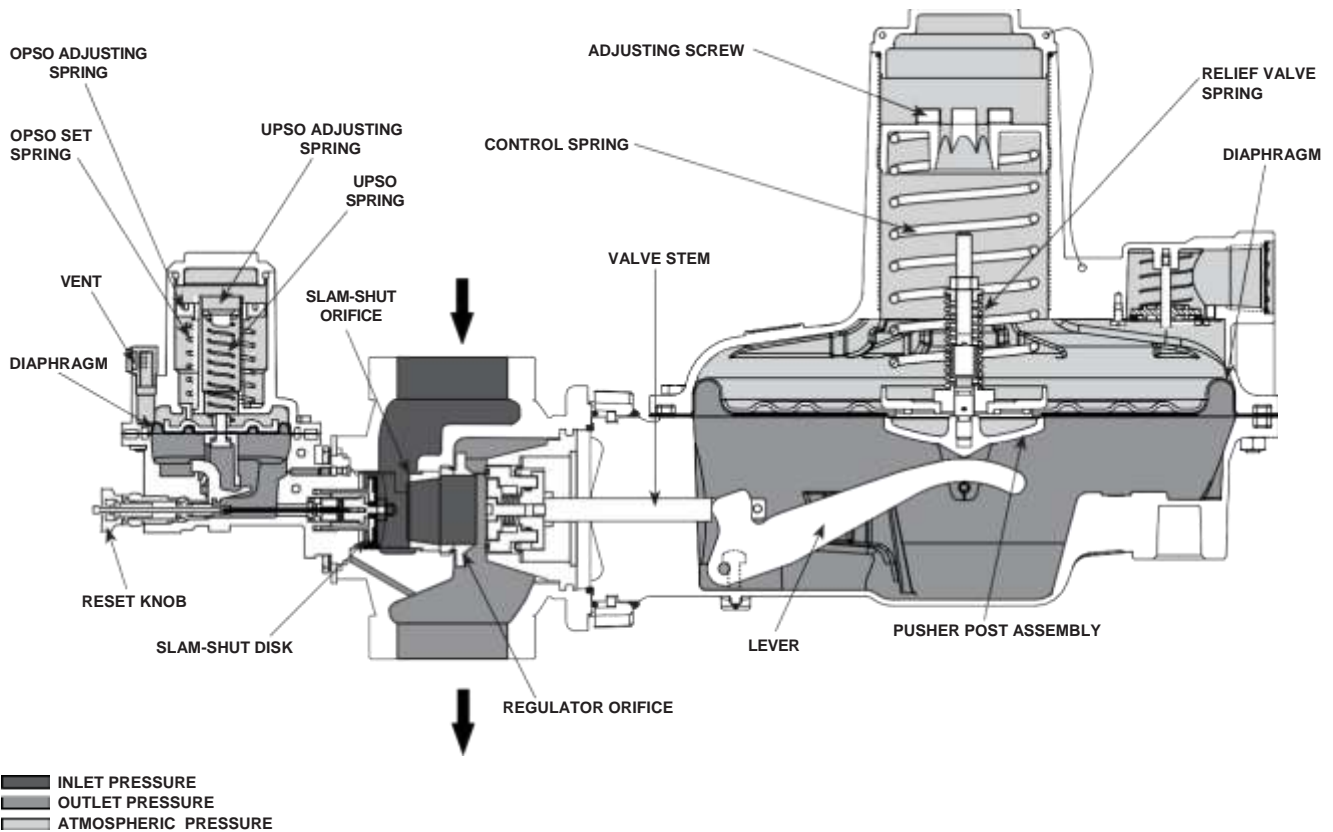

■ INLET PRESSURE
 ■ OUTLET PRESSURE
 ■ ATMOSPHERIC PRESSURE

Figure 5. Type CS804IT Internally Registered Regulator with Slam-shut Module Operational Schematic

If the regulator is exposed to an overpressure condition, it should be inspected for any damage that may have occurred. Regulator operation below these limits does not preclude the possibility of damage from external sources or from debris in the pipeline.

General Installation Instructions

Before installing the regulator,

- Check for damage, which might have occurred during shipment.
- Check for and remove any dirt or foreign material, which may have accumulated in the regulator body.
- Blow out any debris, dirt or copper sulfate in copper tubing and the pipeline.
- Apply pipe compound to the external threads of the pipe before installing the regulator.

Note

Applying pipe compound to internal threads can result in excess pipe compound collecting in the body of the regulator and potentially clog registration ports, affect lockup or downstream equipment.

- Make sure gas flow through the regulator is in the same direction as the arrow on the body. "Inlet" and "Outlet" connections are clearly marked.
- When designing a pressure reducing station using a CS800 Series regulator, make an analysis if it is necessary to take into account the effects of wind, snow and temperature to avoid unnecessary load and movement to the flanges of the equipment.
- If needed, a support may be used under the piping and regulator/slam-shut body to avoid excessive pressure force on the regulator/slam-shut.

Note

For Types CS805, CS825, CS806 and CS826 equipped with the white-colored disk, ensure that the open end of disk is oriented toward the downstream as indicated in Figure 7. If the body direction relative to the actuator is changed during installation, the orientation of the white disk must also be removed, turned and reinstalled to ensure the open end faces downstream.

Installation Location

- The installed regulator should be adequately protected from vehicular traffic and damage from other external sources.
- **Install the regulator with the vent pointed vertically down, see Figure 8.** If the vent cannot be installed in a vertically down position, the regulator must be installed under a separate protective cover. Installing the regulator

with the vent down allows condensation to drain, minimizes the entry of water or other debris from entering the vent and minimizes vent blockage from freezing precipitation.

- **Do not install the regulator in a location where there can be excessive water accumulation or ice formation,** such as directly beneath a downspout, gutter or roof line of building. Even a protective hood may not provide adequate protection in these instances.
- Install the regulator so that any gas discharge through the vent or vent assembly is over 3 ft. / 0.91 m away from any building opening.

Regulators Subjected to Heavy Snow Conditions

Some installations, such as in areas with heavy snowfall, may require a hood or enclosure to protect the regulator from snow load and vent freeze over.

Downstream Control Line Installation

A CS800 Series regulator with an EN or ET in the type number has a blocked throat, an O-ring stem seal and a 3/4 NPT control line tapping in the lower diaphragm casing. A regulator with a downstream control line is used for monitoring installations or other applications where there is other equipment installed between the regulator and the pressure control point.

For types with an EN or ET in the type number, connect downstream control line tubing to the lower casing and run the tubing a distance of approximately 6 times the outlet piping diameter as shown in Figures 9, 10 and 11. For best results, the outer diameter of the control line tubing should be 3/8 in. / 9.5 mm or larger.

Downstream Control Line Installation with Integral True-Monitor™

Refer to Figure 10. When installing the Types CS803ET and CS803EN regulators, connect downstream control line tubing to the lower casing of the Primary Regulator and run the tubing a distance of approximately 6 times the outlet piping diameter downstream of the regulator outlet. Connect a second, separate downstream control line tubing to the lower casing of the Integral Monitor and run the tubing a distance of approximately 6 times the outlet piping diameter downstream of the Integral Monitor outlet. For best results, the outer diameter of the control line tubing for both the Primary Regulator and the Integral Monitor should be 3/8 in. / 9.5 mm or larger.

Installation with External Overpressure Protection

If the regulator is used in conjunction with a Type 289H relief valve, it should be installed as shown in Figure 8. The outside end of the vent line should be protected with a rainproof assembly. The Type 289H should be set 10 in. w.c. / 25 mbar higher than the outlet pressure setting of the regulator, up to 30 in. w.c. / 75 mbar outlet pressure. For pressure greater than this, set the Type 289H 0.75 psi / 52 mbar higher than the outlet pressure setting of the regulator. See the 289 Series Instruction Manual (D100280X012) for more information.

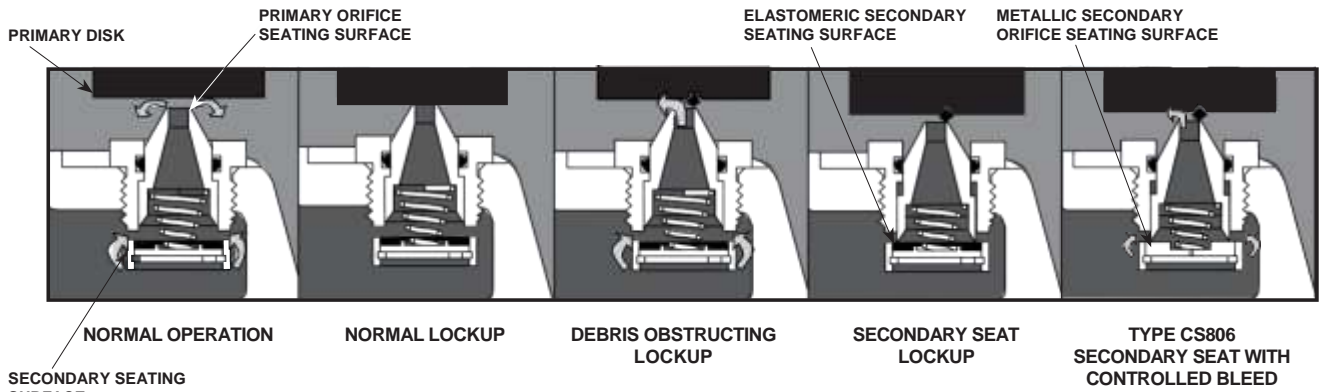

SECONDARY SEAT DETAILED VIEW

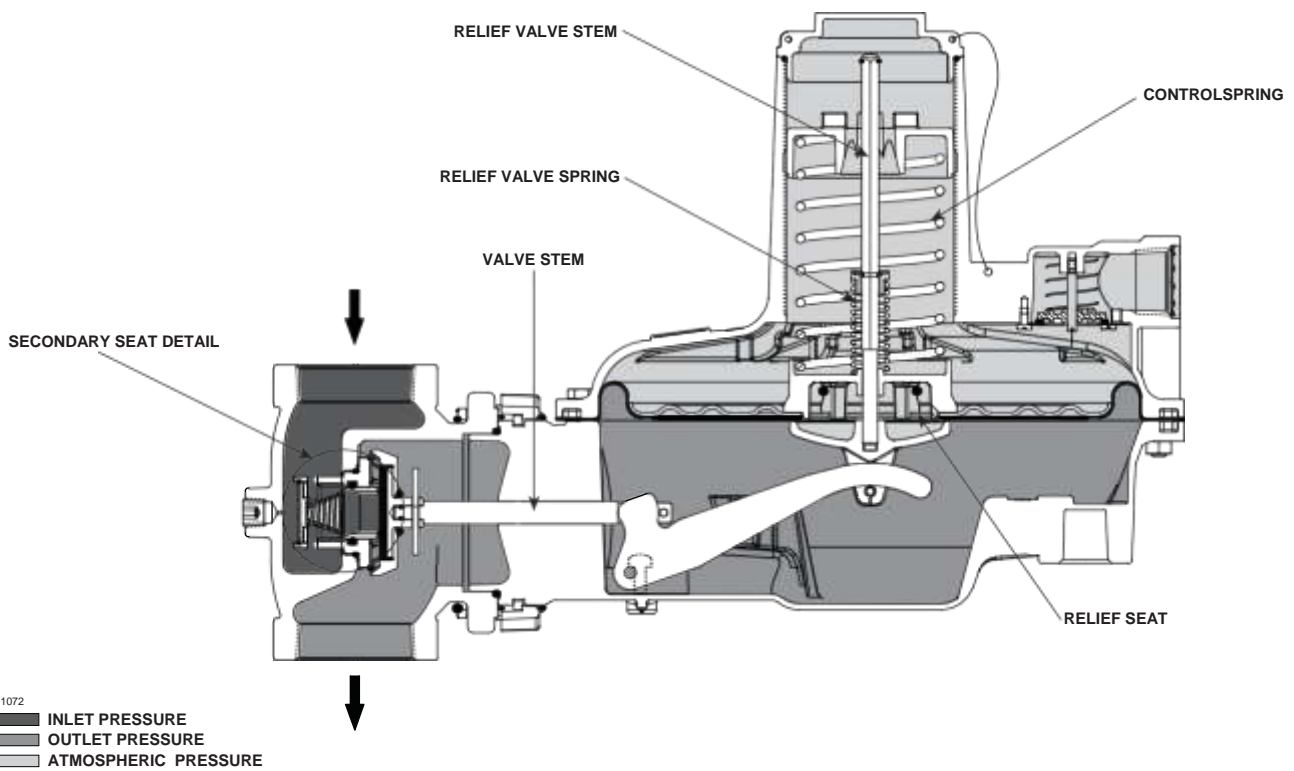

Figure 6. Type CS805IR with Secondary Seat Protection

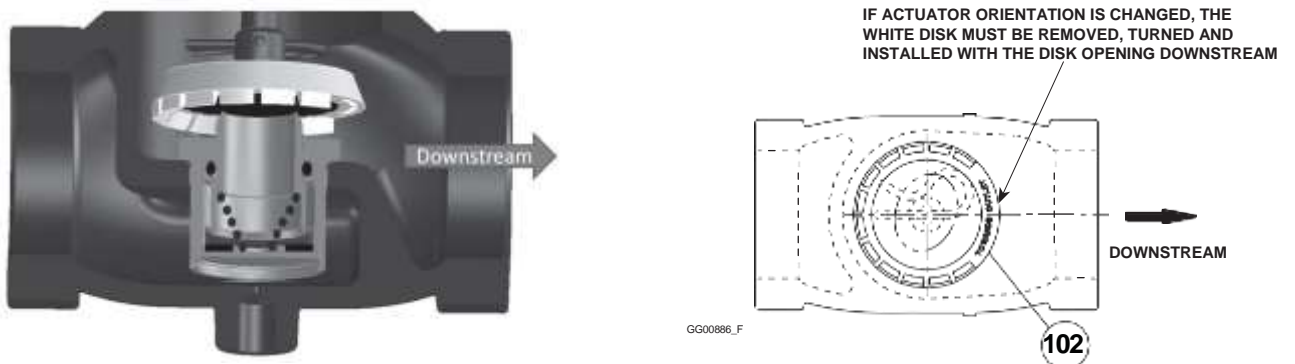

Figure 7. White Disk Orientation for use with Secondary Seat™ Protection

Vent Line Installation

The CS800 Series regulators have a 1 or 2-1/2 NPT screened vent opening in the spring case. If necessary to vent escaping gas away from the regulator, install a remote vent line in the spring case tapping. Vent piping should be as short and direct as possible with a minimum number of bends and elbows. The remote vent line should have the largest practical diameter. Vent piping on regulators with internal relief must be large enough to vent all relief valve discharge to atmosphere without excessive backpressure and resulting excessive pressure in the regulator. Ensure piping is properly supported to avoid excessive stress on the regulator spring case.

The CS800 Series offers optional Token Relief that provides low-capacity relief which is located in the spring case of the Primary Regulator. If necessary to vent escaping gas away, install a remote vent line in the spring case tapping of the Primary Regulator as described above.

Periodically check all vent openings to be sure that they are not plugged.

CS800 Series outlet pressure ranges are shown in Table 5. Outlet pressure greater than 3 psi / 0.21 bar above setpoint may damage internal parts such as the diaphragm head and valve disk. **The maximum emergency (casing) outlet pressure is 15 psig / 1.0 bar.**

Startup

CAUTION

Pressure gauges should always be used to monitor downstream pressure during Startup.

With the downstream system depressurized, perform the following procedure to startup the regulator.

1. Check to see that all appliances are turned off.
2. Slowly open the upstream shut-off valve.
3. Check inlet and outlet pressure for correct values.
4. Check all connections for leaks.
5. Turn on utilization equipment and recheck the pressures.

Adjustment

Note

The range of allowable pressure setting is stamped on the nameplate. If the required setting is not within this range, substitute the correct spring (as shown in Table 5). If the spring is changed, change the nameplate to indicate the new pressure range.

Because of the weight of internal regulator parts, the Red spring, 3.5 to 6 in. w.c. / 9 to 15 mbar spring range (nominal 4 in. w.c. / 10 mbar setting) gives the best pressure control when the regulator spring barrel is

pointed down. Spring barrel down orientation may require that vent piping or vent adaptors are installed to keep the vent pointed down.

For types that include the Integral Monitor module, refer to the Instruction Manual for Type TM600 Integral Monitor, document D103126X012, for Adjustment and Maintenance of the Integral Monitor. For types that include the Slam-shut module, refer to the Instruction Manual for Type VSX8 Slam-shut, document D103127X012, for Adjustment and Maintenance of the Slam-shut.

A pressure gauge should always be used to monitor downstream pressure while adjustments are being made.

1. Remove the closing cap (key 60, Figure 12).

! WARNING

During setpoint adjustment, do not mistake the Token Relief Spring Nut (key 46) for the main spring adjusting screw. Turning the Token Relief Spring Nut will change the token relief setting and if rotated counterclockwise could result in gas discharge and possible personal injury.

2. To increase the outlet setting, turn the adjusting screw (key 65, Figure 12) clockwise. To decrease the outlet setting, turn the adjusting screw counterclockwise.
3. Replace the closing cap or tighten the hex locknut.

Types CS803 and CS823 with Integral True-Monitor™ Module

When adjusting the primary regulator and integral True-Monitor for operation, ensure that the pressure differences between the primary regulator and the integral True-Monitor shown in Tables 8 and 9 are observed. For example, if the primary regulator setpoint is set at 7 in. w.c. / 17 mbar, then the integral monitor should be set at a minimum of 14 in. w.c. / 35 mbar or higher.

To test the integral monitor operation, the primary regulator setpoint must be adjusted above the integral monitor's setpoint to simulate a failure of the primary regulator. If the spring range of the primary regulator is sufficiently high, it can simply be adjusted above the integral monitor's setpoint by following step 2 above. Otherwise, a different spring with a setpoint higher than the integral monitor's setpoint must be installed to check the operation of the integral monitor. An alternative to using a higher set spring on the primary regulator is to attach a hand pump and gauge to the primary regulator vent to pressure load it until its setpoint exceeds that of the integral True-Monitor.

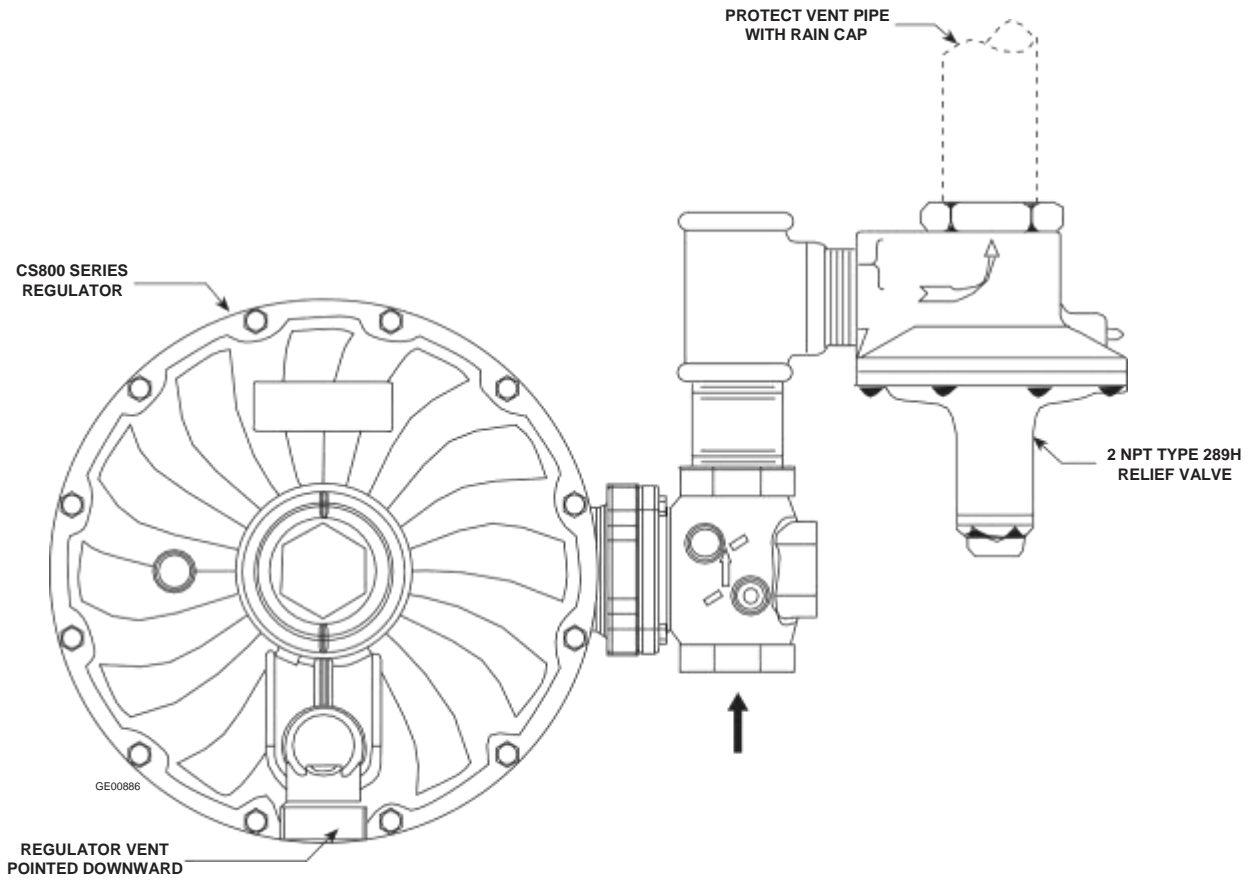

Figure 8. CS800 Series Regulator Installed with the Vent Pointed Downward and with a Type 289H Relief Valve for High Capacity Relief

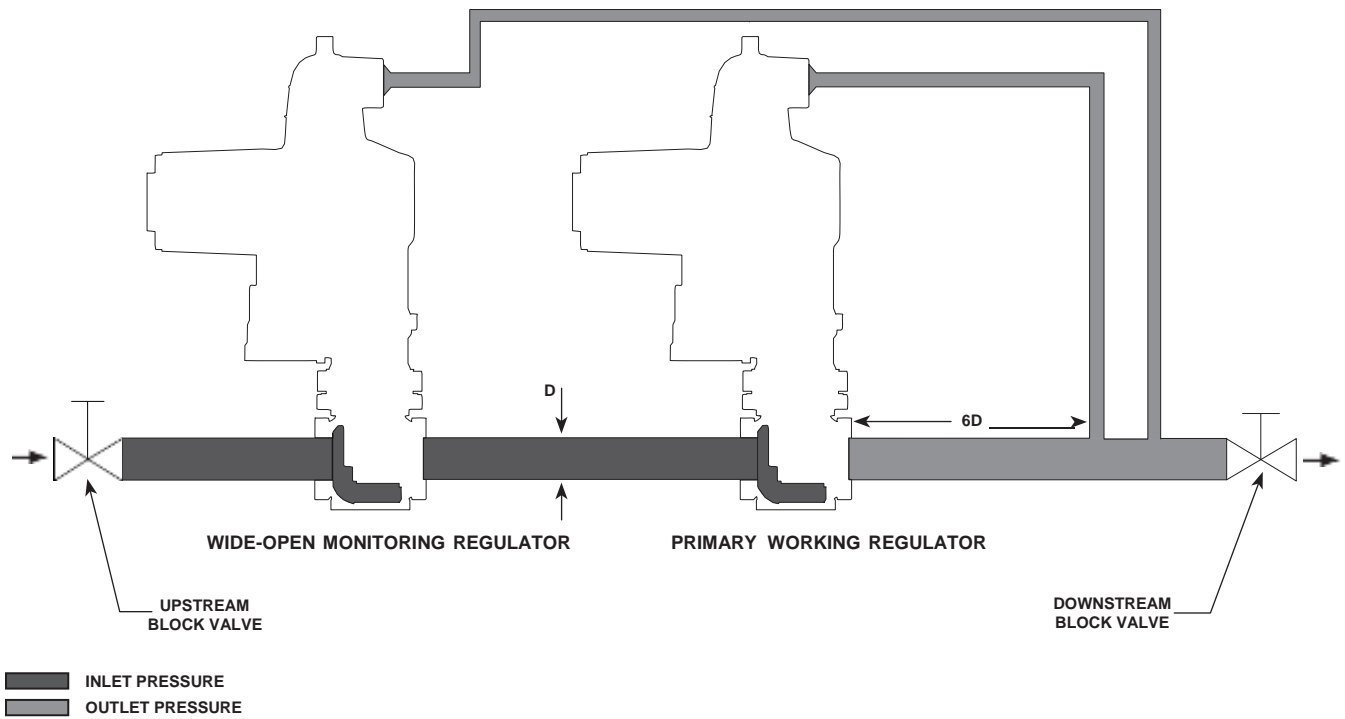

Figure 9. CS800 Series Wide-open Monitor Control Line Installation

CAUTION

When applying pressure to the regulator spring case through the vent, care must be taken not to exceed 3 psig / 0.21 bar, which is the maximum differential across the diaphragm.

Types CS804, CS824 and CS854 with Slam-shut Module

When adjusting the Primary Regulator and Slam-shut for operation, reference Tables 10 and 11 and the footnotes in each table for the OPSO and OPSO/UPS0 setpoints of the slam-shut for the given regulator spring ranges.

CAUTION

Equipment installed downstream the Type VSX8 Slam-shut device can be damaged if the following procedure for resetting the Type VSX8 Slam-shut device is not followed. This equipment includes the integral Type VSX8 or regulator configurations.

1. To properly reset the Type VSX8 Slam-shut after it has been tripped to the closed position, insert a flat-head screwdriver into the position shown in Figure 8 on the backside of the reset button (refer to Type VSX8 Instruction Manual, key 30, Figure 8).
2. Slowly rotate the screwdriver to gradually pull the reset button (refer to Type VSX8 Instruction Manual, key 30) away from the Type VSX8 device. This slow movement allows for a slow bleed of the pressure across the Type VSX8 Slam-shut's disk and seat area. The operator should be able to hear the pressure bleeding through the system.
3. When the pressure has equalized and the air bleeding sound has dissipated, completely pull the reset button (refer to Type VSX8 Instruction Manual, key 30) away from the Type VSX8 Slam-shut device by hand until the internal shut-off mechanism has been re-latched.
4. Once the operator feels the click of the re-latch occurring, completely push the reset button (refer to Type VSX8 Instruction Manual, key 30) back into its original position.

Shutdown

Installation arrangements may vary, but in any installation it is important that the valves be opened or closed slowly and that the outlet pressure be vented before venting inlet pressure to prevent damage caused by reverse pressurization of the regulator. The steps below apply to the typical installation as indicated.

1. Open valves downstream of the regulator.
2. Slowly close the upstream shut-off valve.

3. Inlet pressure should be released automatically downstream as the regulator opens in response to the lowered pressure on the diaphragm.
4. Close outlet shut-off valve.

Maintenance and Inspection

! WARNING

To avoid personal injury or equipment damage, do not attempt any maintenance or disassembly without first isolating the regulator from system pressure and relieving all internal pressure as described in "Shutdown" section.

Test the regulator that has been disassembled for repair to ensure that it is operating properly before being returned to service. Only parts manufactured by Emerson should be used for repairing Fisher™ regulators. Restart gas utilization equipment according to normal Startup procedures.

Due to normal wear or damage that may occur from external sources, inspect and maintain this regulator periodically. The frequency of inspection and replacement of parts depends upon the severity of service conditions or the requirement of local, state and federal rules and regulations.

Perform periodic inspection on Wide-Open Monitor regulators, Integral True-Monitor™ or Slam-shut overpressure protection modules to ensure protection of the downstream system in the event of a failure to the primary regulator. This inspection must test that the wide open monitor, Integral True-Monitor or Slam-shut functions as intended.

Maintenance on CS800 Series with Secondary Seat™ Protection

Types CS805 and CS825 regulators do not have any means to alert when the Secondary Seat operates at lockup. A lock-up test can be done on the regulator to determine if the lock-up pressure has elevated to or near the values in Table 7, under the heading Types CS805 and CS825. If so, replace the regulator primary disk and orifice.

Internal relief operation on units equipped with Secondary Seat Protection is an indication that the Secondary Seat Protection on the Types CS805IR and CS805IQ may not be working and that the Types CS806IR and CS806IQ Secondary Seat may have closed. Maintenance should address any potential causes for internal relief operation as well as other regulator malfunctions separate from the Secondary Seat.

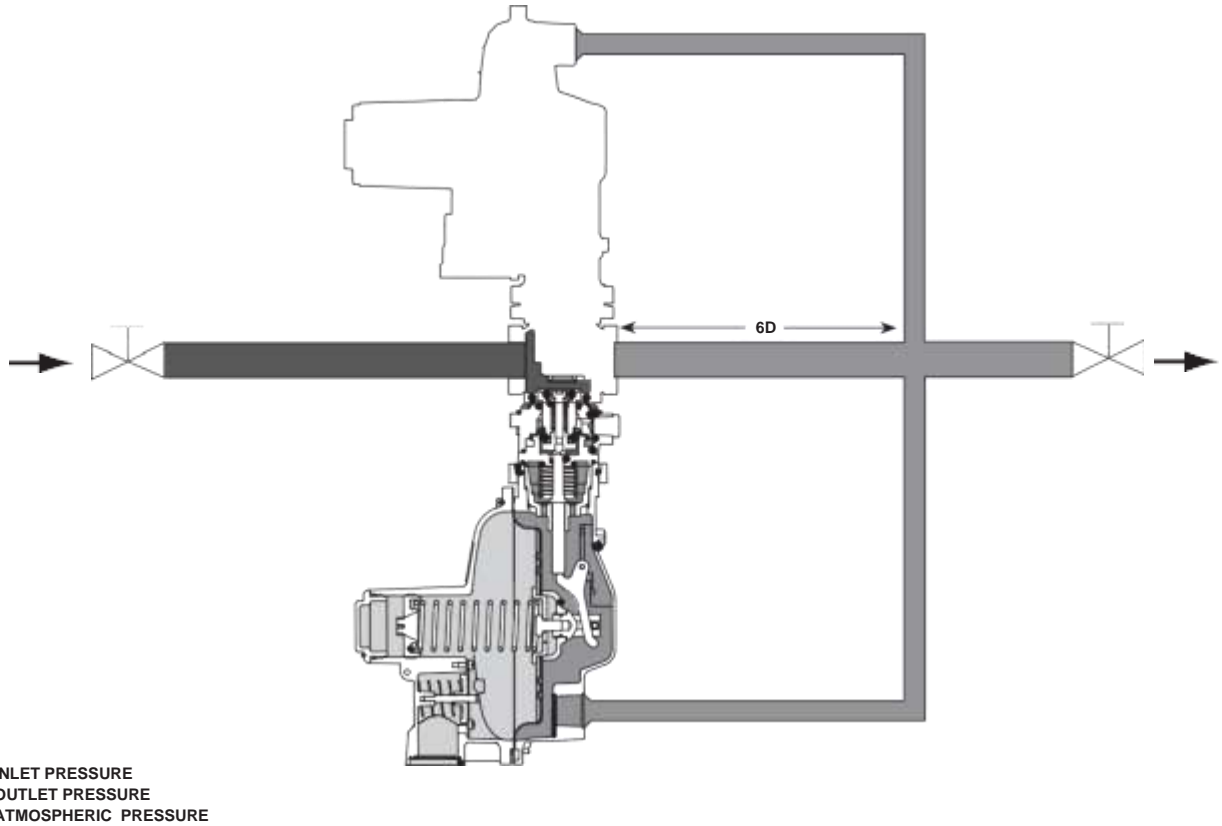

Figure 10. Externally Registered Types CS803 and CS823 Regulator and Integral True-Monitor™ Downstream Control Line Installation

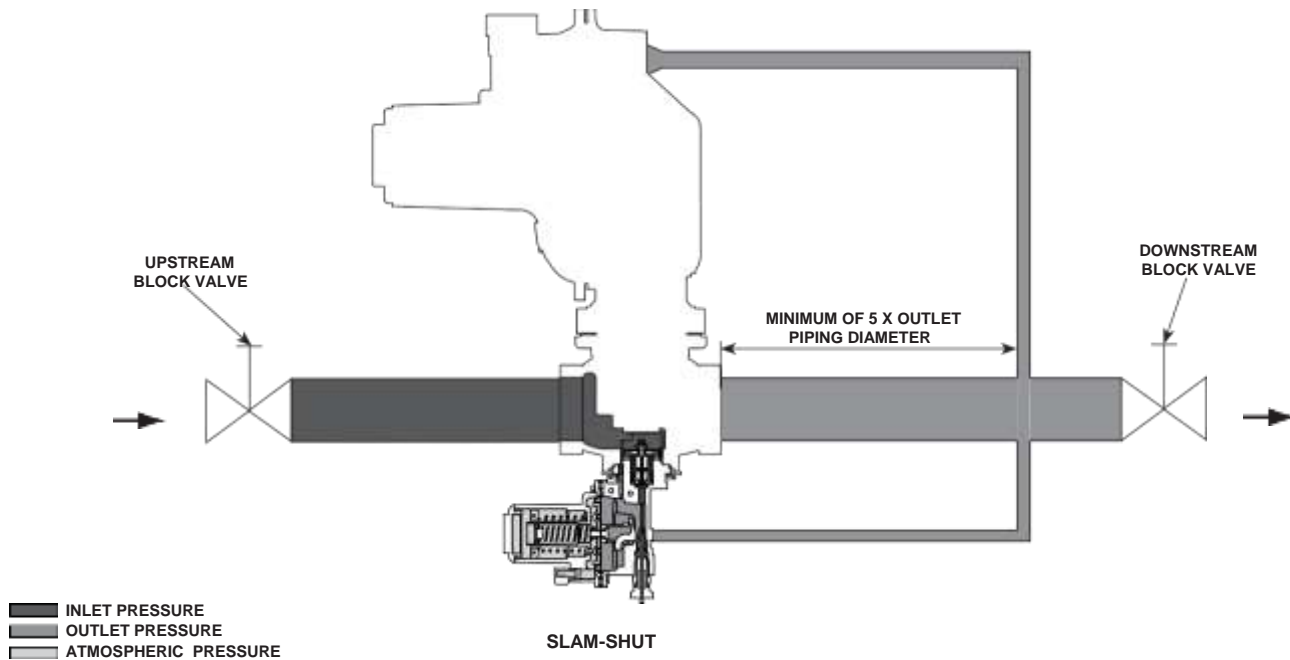

Figure 11. Externally Registered Types CS804, CS824 and CS854 Regulator and Slam-shut Downstream Control Line Installation

Maintenance on CS800 Series

Disassembly to Replace Diaphragm (See Figures 12, 14 and 16)

1. See Figure 16. All Types except Type CS850, remove the closing cap (key 60). Turn the adjusting screw (key 65) counterclockwise to ease spring compression. Remove adjusting screw and spring (key 38).
2. See Figure 16. Type CS850, loosen hex locknut (key 107). Turn adjusting screw (key 65) counterclockwise to ease spring compression. Unscrew bonnet (key 104) and remove. Remove spring (key 38).
3. See Figure 12. Remove the nuts (key 16) and hex bolts (key 15). Separate the upper spring case (key 1) from the lower casing (key 9).

Note

When disassembling a CS800 Series regulator, lift the upper spring case straight up in order to avoid hitting the stem (key 11).

4. See Figure 12. Slide the diaphragm head assembly (key 55) away from the body (key 70) to unhook the pusher post (key 50) from the lever (key 10). Lift off the diaphragm head assembly.
5. See Figure 14. Non-Relieving units, unscrew the bolt (key 45). The bolt threads in to the pusher post (key 50) and holds the non-relieving diaphragm assembly together. Unscrewing the bolt will separate the diaphragm retainer (key 47), the lower spring seat (key 43) and diaphragm assembly (key 55) and pusher post (key 50).

CAUTION

Use caution when unscrewing the relief valve stem as the relief valve spring is in compression.

See Figure 14. Internally Relieving units, unscrew the relief valve stem (key 44). The relief valve stem threads into the pusher post (key 50) and holds the relieve assembly together. Unscrewing the relief valve stem will separate the E-Ring (key 48), the spring retainer (key 42), the relief spring (key 41), the lower spring seat (key 43) and the diaphragm assembly (key 55) onto the pusher post (key 50).

See Figure 14. Token Relieving units, measure and note for reassembly, the distance between the top of the diaphragm stem (key 44) and the top of the token relief hex nut (key 46). Unscrew token relief nut with a 1/2 in. / 13 mm wrench. Remove the spring seat (key 42) and relief spring (key 41). Unthread the second lower nut (key 46). Pull the pusher post assembly (key 50) through the diaphragm assembly. Replace the pusher post O-ring (key 52) and diaphragm stem O-ring (key 115). Unscrew the pusher post nut (key 110), which allows for separation of the lower spring seat (key 43), diaphragm assembly (key 55) and the pusher post retainer (key 111).

6. Reassemble in the reverse order of step five. For the Token Relief Assembly, ensure the distance from the top of the diaphragm stem (key 44, Figure 14) to the top of the token relief hex nut (key 46) is the same as before disassembly. When assembling the diaphragm (key 55A) onto the diaphragm head (key 55B), apply a small amount of adhesive on the outer flat portion of the diaphragm head that contacts the diaphragm, as indicated in Figure 14. Place the diaphragm head on the diaphragm and check to ensure the hole in the diaphragm head with the hole of the diaphragm are concentrically aligned.
7. Place the diaphragm assembly into position in the lower casing; make sure that the pusher post is hooked on the lever.

Note

See Figure 12. To ease in the process of inserting the diaphragm assembly into the lower case (key 9) and hooking it onto the lever (key 10), loosen the four body bolts (key 71). This will allow the lever to be rotated upward in order to slide the diaphragm assembly (key 55) onto the lever.

8. After the diaphragm assembly is hooked to the lever, rotate the diaphragm so that the diaphragm and lower casing holes are aligned.
9. Reassemble the remaining parts by following steps 1 to 3 in reverse order.

Note

See Figure 12, always tighten bolts in a cross pattern.

Disassembly to Replace Valve Stem O-ring (For externally registered Types only, e.g., Type CS800EN) (See Figures 12, 15 and 16)

1. See Figure 12. Remove the four body bolts (key 71) and remove the body (key 70).
2. Check the body O-ring (key 19) for wear and replace as necessary.
3. See Figure 16.
 - a. All types except Type CS850, remove the closing cap (key 60). Turn the adjusting screw (key 65) counterclockwise to ease spring compression. Remove adjusting screw and spring (key 38).
 - b. Type CS850, loosen hex locknut (key 107). Turn adjusting screw (key 65) counterclockwise to ease spring compression. Unscrew bonnet (key 104) and remove. Remove spring (key 38).
4. See Figure 12. Remove the nuts (key 16) and hex bolts (key 15). Separate the upper spring case (key 1) from the lower casing (key 9).

Note

When disassembling a CS800 Series regulator, lift the upper spring case straight up in order to avoid hitting the stem (key 11).

5. Slide the diaphragm head assembly (key 55) away from the body (key 70) to unhook the pusher post (key 50) from the lever (key 10). Lift off the diaphragm head assembly.
6. Remove the two lever retaining screws (key 14). Lift lever up slightly and then slide in the direction away from the body. Once the lever pin (key 13) has cleared the lower actuator the lever can be lowered and at the same time rotated upward to allow it to be removed from the slotted stem (key 11).
7. See Figure 15. Remove the disk retainer clip (key 36B) and then remove the disk assembly (key 36). Remove the stem (key 11) by sliding it in the direction away from the body.
8. Replace stem O-ring (key 12) making certain to apply lubricant.
9. Reassemble in the reverse order.

Note

When placing the diaphragm assembly into position in the lower casing, make sure that the pusher post is hooked on the lever. After the diaphragm assembly is hooked to the lever, rotate the diaphragm so that the diaphragm and lower casing holes are aligned.

See Figure 12, always tighten bolts in a cross pattern.

10. Reassemble the remaining parts by following steps 1 to 3 in reverse order.

Disassembly to Replace Valve Disk and Orifice (See Figures 12 and 18)

1. Remove the four hex bolts (key 71) which hold the lower spring case (key 9) to the body (key 70). Separate the lower spring casing from the body.
2. Check the body O-ring (key 19) for wear and replace as necessary.

Note

There are multiple disk assemblies based on construction and these are identified by color. See Tables 13, 14 and 15 for direction in selecting appropriate disk color. Product performance will be changed if the incorrect disk assembly is used.

3. Examine the disk assembly (key 36) for nicks, cuts and other damage. To replace, remove the disk retainer clip (key 36B) and slide the disk assembly off of the stem (key 11).
4. See Figure 18.

- a. If the seating edge of the CS800 Series orifice (key 25) is nicked or rough, remove the orifice from the body using a 2 in. / 50 mm socket wrench.
- b. If equipped with a CS805/CS806 Series Secondary Seat orifice assembly, see the following section "Disassembly to Replace Valve Disk and Secondary Seat orifice assembly" for maintenance instructions.

Note

If the orifice is replaced with a different size, change the nameplate to state the new size and maximum inlet pressure (see Table 4).

5. Replace O-ring (key 82). Apply anti-seize lubricant to the external threads of the new orifice/orifice assembly and reassemble into the body. Install the orifice per Figure 17 and tighten the orifice or orifice subassembly into the body per Figure 12.
6. Reassemble the regulator in reverse order of the above steps. O-ring (key 28, Figure 12) on end of stem (key 11) should be lubricated before replacing the disk assembly. This O-ring is not a pressure retaining part but keeps the disk holder from rattling on the stem.

Note

See Figure 12, always tighten bolts in a cross pattern.

Disassembly to Replace Valve Disk and Secondary Seat™ Orifice Assembly (See Figure 12)

1. Remove the four hex bolts (key 71) which hold the lower spring case (key 9) to the body (key 70). Separate the lower spring casing from the body.
2. Check the body O-ring (key 19) for wear and replace as necessary.

Note

There are multiple disk assemblies based on construction and these are identified by color.

See Tables 13, 14 and 15 for direction in selecting appropriate disk color. Product performance will be changed if the incorrect disk assembly is used.

If the White disk is selected, the open side of the disk must be directed toward the outlet of the body as indicated in Figure 7.

3. Examine the disk assembly (key 36) for nicks, cuts and other damage. To replace, remove the disk retainer clip (key 36B) and slide the disk assembly off of the stem (key 11).
4. See Figure 19. Remove the orifice assembly from the body using a 2 in. / 50 mm socket wrench.

Table 12. Adjustment Tools

KEY NUMBER	PART DESCRIPTION	ADJUSTMENT TOOL
15	Hex Bolt	1/2 in. / 13 mm Socket
16	Nut	1/2 in. / 13 mm Socket
25	Orifice/Seat	2 in. / 50 mm Socket
44	Relief Valve Stem	9 mm Socket or Adjustable End Wrench
45	Bolt, Diaphragm Assembly	1/2 in. / 13 mm Socket
60	Closing Cap	2 in. / 50 mm Socket
65	Adjusting Screw, up to 2.5 psig / 0.17 bar spring range	7/8 in. Hex/Allen Wrench
		2 in. / 50 mm Socket
		1/2 in. / 13 mm Socket
		Large Flat head Screw Driver
	Adjusting Screw, 2 to 5.5 psig / 0.17 to 0.38 bar spring range	1/2 in. / 13 mm Socket Driver Extension
	Adjusting Screw, above 5 psig / 0.34 bar spring range	15/16 in. / 24 mm or Adjustable End Wrench
71	Body Bolt	1/2 in. / 13 mm Socket
72	1/4 NPT Pipe Plug	1/4 in. Hex/Allen Wrench

1. Use of Adjustment tool is optional.

Inspect the primary seating surface as well as the secondary seating surface and sealing surface. If nicks or other damage are present, start to disassemble the Secondary Seat™ assembly by removing the internal retaining ring (key 25D) with retaining ring pliers. Use care when removing the internal retaining ring as the spring (key 25F) is compressed and will exert force on the Secondary Seat disk (key 25C).

5. Remove the Secondary Seat disk (key 25C), spring (key 25F) and double sided orifice (key 25B). Finally, remove the orifice O-ring (key 25E). Lubricate O-ring with extreme low temperature bearing grease or similar lubricant that maintains its lubrication properties at cold temperatures and replace O-ring. Insert the new double-sided orifice (key 25B), then the spring (key 25F), ensuring that the larger diameter opening is contacting the shelf of the orifice.
6. Replace the Secondary Seat disk (key 25C). See Figure 19.
 - a. For Types CS805 and CS825 ensure that the rubber/Nitrile (NBR) sealing surface is facing the Secondary Seating surface of the orifice.
 - b. For Types CS806 and CS826, ensure that the hole in the center of the disk that acts as the spring seat is facing the spring.
7. Press the disk inside the housing (key 25A) to allow the internal retaining ring to be reinserted.

Note

If the orifice is replaced with a different size, change the nameplate to state the new size and maximum inlet pressure (see Table 4).

8. Replace O-ring (key 82). Apply anti-seize lubricant to the external threads of the new orifice/orifice assembly and reassemble into the body. Install and tighten the orifice per Figure 12.

9. Reassemble the regulator in reverse order of the above steps. O-ring (key 28) on end of stem (key 11) should be lubricated before replacing the disk assembly. The O-ring is not a pressure retaining part but keeps the disk holder from rattling on the stem.

Note

See Figure 12, always tighten bolts in a cross pattern.

Regulator Reassembly

It is recommended that a good quality pipe thread sealant be applied to pressure connections and fittings and a good quality lubricant be applied to all O-rings. Also apply an anti-seize compound to the adjusting screw threads and other areas as needed. Reference Figures 12 through 19 to determine the recommended lubricant/sealant/adhesive for these parts. All lubricants/sealants/adhesives must be selected such that they meet the temperature requirements.

When reassembling, torque bolts and fasteners per torque values are indicated on Figures 12 through 19. Some relaxation from initial torque values may occur. Always tighten bolts in a cross pattern.

Parts Ordering

The type number, orifice size, spring range and date of manufacture are stamped on the nameplate. Always provide this information in any correspondence with your local Sales Office regarding replacement parts or technical assistance.

When ordering replacement parts, reference the key number and the 11-digit Part Number of each needed part as found in the following parts list. Separate repair part kits containing all recommended elastomer spare parts are available.



Table 13. CS800 Series Disk Color Selection

PRESSURE REGISTRATION	TYPE	BODY SIZE		SPRING RANGE ⁽¹⁾		BODY MATERIAL	END CONNECTION	DISK COLOR	DISK ASSEMBLY PART NUMBER	REPAIR KIT ⁽²⁾
		In.	DN	In. w.c.	mbar					
Internal	CS800	1-1/4 and 1-1/2	32 and 40	3.5 to 30	9 to 75	All Materials	All Connections	Black	GE29773X022	RCS800XBLK2
		2	50	3.5 to 6	9 to 15	All Materials	All Connections	Green	GE29773X042	RCS800XGRN2
				5.5 to 8.5 and 8 to 12	13 to 21 and 20 to 30	Gray Cast Iron	All Connections	Blue	GE29773X032	RCS800XBLU2
						Ductile Iron or WCC Steel	Flanged	Blue	GE29773X032	RCS800XBLU2
				Threaded	Dark Gray	GE29773X082	RCS800XGRY2			
			10 to 16 and 14 to 30	25 to 40 and 35 to 75	All Materials	All Connections	Green	GE29773X042	RCS800XGRN2	
	CS820 and CS850	All Sizes		1 to 10 psig	69 to 690	All Materials	All Connections	Black	GE29773X022	RCS800XBLK2
External	All	All Sizes		All		All Materials	All Connections	Black	GE29773X022	RCS800XBLK2

1. The 3.5 to 30 in. w.c. / 9 to 75 mbar spring range indicates that all of the springs within this range are applicable.
2. Repair kit includes O-ring (key 19), disk assembly (key 36) and O-ring (key 62).

Table 14. CS803 and CS804 Series Disk Color Selection

PRESSURE REGISTRATION	TYPE	BODY SIZE		SPRING RANGE ⁽¹⁾		BODY MATERIAL	END CONNECTION	DISK COLOR	DISK ASSEMBLY PART NUMBER	REPAIR KIT ⁽²⁾
		In.	DN	In. w.c.	mbar					
Internal	CS803 and CS804	1-1/2	40	3.5 to 30	9 to 75	All Materials	All Connections	Black	GE29773X022	RCS800XBLK2
		2	50	3.5 to 6	9 to 15	All Materials	All Connections	Green	GE29773X042	RCS800XGRN2
				5.5 to 8.5 and 8 to 12	13 to 21 and 20 to 30	Ductile Iron or WCC Steel	Flanged	Blue	GE29773X032	RCS800XBLU2
							Threaded	Dark Gray	GE29773X082	RCS800XGRY2
				10 to 16 and 14 to 30	25 to 40 and 35 to 75	All Materials	All Connections	Green	GE29773X042	RCS800XGRN2
	CS823, CS824 and CS854	All Sizes		1 to 10 psig	69 to 690	All Materials	All Connections	Black	GE29773X022	RCS800XBLK2
External	All	All Sizes		All		All Materials	All Connections	Black	GE29773X022	RCS800XBLK2

1. The 3.5 to 30 in. w.c. / 9 to 75 mbar spring range indicates that all of the springs within this range are applicable.
2. Repair kit includes O-ring (key 19), disk assembly (key 36) and O-ring (key 62).

Table 15. CS805 and CS806 Series Disk Color Selection

PRESSURE REGISTRATION	TYPE	BODY SIZE		SPRING RANGE ⁽¹⁾		BODY MATERIAL	END CONNECTION	DISK COLOR	DISK ASSEMBLY PART NUMBER	REPAIR KIT ⁽³⁾
		In.	DN	In. w.c.	mbar					
Internal	CS805 and CS806	1-1/4	32	3.5 to 30	9 to 75	Gray Cast Iron	All Connections	Yellow/White Dot	GE29773X062	RCS800XYEL2
		1-1/2	40					Green/White Dot	GE29773X092	RCS800XGR22
		2	50					White/White Dot ⁽²⁾	GE29773X052	RCS800XWHT2
	CS825 and CS826	All Sizes		1 to 5.5 psig	70 to 380	Gray Cast Iron	All Connections	Yellow/White Dot	GE29773X062	RCS800XYEL2
External	All	All Sizes		All		All Materials	All Connections	Black	GE29773X022	RCS800XBLK2

1. The 3.5 to 30 in. w.c. / 9 to 75 mbar spring range indicates that all of the springs within this range are applicable.
2. White/White Dot disk requires the open end to be directed downstream with the direction of flow.
3. Repair kit includes O-ring (key 19), disk assembly (key 36) and O-ring (key 62).

Parts List

Key	Description	Part Number	Key	Description	Part Number
Regulator Repair Kit					
	Disk Assembly Repair Kit [Disk Assembly Repair Parts kit includes O-ring (key 19), disk assembly (key 36) and O-ring (key 62).] See Tables 13, 14 and 15		2	Vent Screen, Stainless steel 1 NPT vent size 2-1/2 NPT vent size	T1121338982 GE29700X012
	Orifice Repair Kit [Orifice Repair Parts kit includes keys 25 (Orifice) and 82 (O-ring).] 1/4 in. / 6.4 mm orifice size 3/8 in. / 9.5 mm orifice size 1/2 in. / 13 mm orifice size 5/8 in. / 16 mm orifice size 3/4 in. / 19 mm orifice size 7/8 in. / 22 mm orifice size 1 in. / 25 mm orifice size 1-3/8 in. / 35 mm orifice size	GE31286X012 GE31287X012 GE31288X012 GE31289X012 GE31290X012 GE31291X012 GE31292X012 GE31294X012	3	Retaining Ring 1 NPT vent size, Zinc-plated steel 2-1/2 NPT vent size, Stainless steel	T1120925072 GE29714X012
	True-Monitor™ Repair Kit [When ordering repair kits for Types CS803 and CS823, it is necessary to order both a Primary Regulator Repair Kit found on Tables 13, 14 and 15 and a True Monitor Repair Kit. See the Type TM600 Instruction Manual for details on which parts are included.]	RTM600X0012	4	Stabilizer Guide, Stainless steel 1 NPT vent size 2-1/2 NPT vent size	GE27061X012 GE27028X012
	Secondary Seat™ Repair Kit [Disk or Backplate Repair Parts kit includes disk or backplate (key 25C) and O-ring (keys 25E and 82). Orifice Assembly Repair Parts kit includes orifice assembly (key 25) and O-ring (key 82).] <i>Types CS805 and CS825 Secondary Seat without Bleed</i> Disk or Backplate Repair Parts Kit For use with 3/8 and 1/2 in. / 9.5 and 13 mm orifice sizes For use with 5/8, 3/4 and 7/8 in. / 16, 19 and 22 mm orifice sizes Orifice Assembly Repair Parts Kit 3/8 in. / 9.5 mm orifice size 1/2 in. / 13 mm orifice size 5/8 in. / 16 mm orifice size 3/4 in. / 19 mm orifice size 7/8 in. / 22 mm orifice size <i>Types CS806 and CS826 Secondary Seat with Bleed</i> Disk or Backplate Repair Parts Kit For use with 3/8 and 1/2 in. / 9.5 and 13 mm orifice sizes For use with 5/8, 3/4 and 7/8 in. / 16, 19 and 22 mm orifice sizes Orifice Assembly Repair Parts Kit 3/8 in. / 9.5 mm orifice size 1/2 in. / 13 mm orifice size 5/8 in. / 16 mm orifice size 3/4 in. / 19 mm orifice size 7/8 in. / 22 mm orifice size	RCS805X0022 RCS805X0032 RCS805RFC38 RCS805RFC12 RCS805RFC58 RCS805RFC34 RCS805RFC78 RCS806X0022 RCS806X0032 RCS806RFC38 RCS806RFC12 RCS806RFC58 RCS806RFC34 RCS806RFC78	5	Stabilizer 1 NPT vent size 2-1/2 NPT vent size	GE46735X012 GE27034X012
	Slam-shut Repair Kit See Type VSX8 Instruction Manual D103127X012		6	Stabilizer Spring, Stainless steel 1 NPT vent size 2-1/2 NPT vent size	GE35010X012 GE29718X012
	Stability Cartridge Kit Kit includes Key (120 and 19)	RCS800STBA0	7	Stabilizer Retainer Ring, Steel/Nitrile (NBR) 1 NPT vent size 2-1/2 NPT vent size	GE46526X012 GE46547X012
1	Upper Spring Case, Aluminum 1 NPT vent size 2-1/2 NPT vent size	GE26101X012 GE26102X012	8	Stabilizer screw (3 required), Zinc-plated steel	GE29724X012
			9	Lower Spring Case, Aluminum Internal Sensing External Sensing	GE26104X012 GE46833X012
			10	Lever, Steel	GE27408X012
			11	Stem, Stainless steel	GE27021X012
			12*	O-ring, Nitrile (NBR) (external sensing only)	GE29753X012
			13	Lever Pin, Steel	GE29701X012
			14	Lever Pin Screw, Plated steel (2 required)	GE30039X012
			15	Hex head cap screw, Steel (12 required)	GE29973X012
			16	Nut, Steel (10 required)	GE30042X012
			17	Union Ring, Aluminum	GE26416X012
			18	Snap Ring, Music wire	GE27018X012
			19*	O-ring, Nitrile (NBR)	GE29755X012
			25*	Orifice, Aluminum Standard (For configurations without Secondary Seat Assembly) 1/4 in. / 6.4 mm 3/8 in. / 9.5 mm 1/2 in. / 13 mm 5/8 in. / 16 mm 3/4 in. / 19 mm 7/8 in. / 22 mm 1 in. / 25 mm 1-3/8 in. / 35 mm	GE29702X012 GE29703X012 GE29704X012 GE29705X012 GE29706X012 GE29707X012 GE29708X012 GE29710X012
			25*	Orifice Assembly, Brass/Nitrile (NBR) For configurations with Secondary Seat Assembly For Types CS805 and CS825 without Bleed 3/8 in. / 9.5 mm 1/2 in. / 13 mm 5/8 in. / 16 mm 3/4 in. / 19 mm 7/8 in. / 22 mm For Types CS806 and CS826 with Bleed 3/8 in. / 9.5 mm 1/2 in. / 13 mm 5/8 in. / 16 mm 3/4 in. / 19 mm 7/8 in. / 22 mm	GE29965X012 GE29968X012 GE29985X012 GE29986X012 GE29987X012 GE29970X012 GE29972X012 GE29989X012 GE29990X012 GE29991X012
			25A	Housing, Brass 3/8 in. / 9.5 mm 1/2 in. / 13 mm 5/8 in. / 16 mm 3/4 in. / 19 mm 7/8 in. / 22 mm	GE29940X012 GE29947X012 GE29947X012 GE29947X012

*Recommended spare part

Key	Description	Part Number	Key	Description	Part Number
25B	Orifice, Brass 3/8 in. / 9.5 mm 1/2 in. / 13 mm 5/8 in. / 16 mm 3/4 in. / 19 mm 7/8 in. / 22 mm	GE29941X012 GE29942X012 GE29948X012 GE29949X012 GE29950X012	45	Hex Head Bolt, Steel Types CS800 and CS820 Type CS850	GE32061X012 GE29974X012
25C*	Disk Types CS805 and CS825 without bleed Types CS806 and CS826 with bleed	GE29943X012 GE32017X012	46	Token Relief Nut, Steel Token Relief (Low Flow) Token Relief (Standard Flow)	GE30042X012 GE30042X012
25D	Internal Ring, Zinc-plated steel	GE29945X012	47	Diaphragm Retainer, Aluminum Types CS800 and CS820 No Relief Token Relief (Standard Flow) Type CS850	GE27027X012 ERAA00916A0 GE47664X012
25E*	O-ring, Nitrile (NBR) 3/8 in. / 9.5 mm 1/2 in. / 13 mm 5/8 in. / 16 mm 3/4 in. / 19 mm 7/8 in. / 22 mm	GE29958X012 GE29958X012 GE29756X012 GE29756X012 GE29756X012	48	Retaining E-Ring, Copper Standard Relief (High Capacity Relief) Low Start-to-Discharge for Standard Relief (High Capacity Relief)	GE33106X012 GE33106X012
25F	Spring, Music wire or Stainless steel 3/8 in. / 9.5 mm 1/2 in. / 13 mm 5/8 in. / 16 mm 3/4 in. / 19 mm 7/8 in. / 22 mm	GE29944X012 GE29944X012 GE29951X012 GE29951X012 GE29951X012	50	Pusher Post No Relief, Aluminum Token Relief (Standard Flow), Aluminum Token Relief (Low Flow), Zinc-plated steel Standard Relief (High Capacity Relief), Aluminum Low Start-to-Discharge for Standard Relief (High Capacity Relief), Aluminum	GE44924X012 GE44947X012 GE46958X012 GE44947X012 GE44947X012
26	Overpressure Protection Orifice, Aluminum For configurations with True-Monitor™ For configurations with Slam-shut	GE30327X012 GE32066X012	52*	Pusher Post O-ring, Nitrile (NBR) Token Relief (Low Flow) only	GE47389X012
27	Overpressure Protection Orifice O-ring, Nitrile (NBR) For configurations with True-Monitor or Slum-shut	GE32723X012	53	Pusher Post Pin, Stainless steel	GE29761X012
28	O-ring, Nitrile (NBR)	GE01439X012	54	Roller Pin, Brass	GE27060X012
36*	Disk Assembly (See Tables 13, 14 and 15, Disk Color Selection) Black Blue Green Dark Gray Green/White Dot White/White Dot Yellow/White Dot	GE29773X022 GE29773X032 GE29773X042 GE29773X082 GE29773X092 GE29773X052 GE29773X062	55	Diaphragm Assembly Types CS800 and CS820 Type CS850	GE29775X012 GE47296X012
36B	Retaining Disk Clip, Stainless steel	GE33709X012	55A*	Diaphragm, Nitrile (NBR)	GE29721X012
38	Spring	See Table 5	55B	Diaphragm Head, Zinc-plated steel Types CS800 and CS820 Type CS850	GE27019X012 GE46996X012
41	Relief Valve Spring, Stainless steel 25 to 35 in. w.c. / 62 to 87 mbar, Token Relief (Standard Flow) 6 to 14 in. w.c. / 15 to 35 mbar, Token Relief (Standard Flow) Token Relief (Low Flow) Standard Relief (High Capacity Relief) Low Start-to-Discharge for Standard Relief (High Capacity Relief)	ERAA17935A0 GE48120X012 GE48120X012 GE30347X012 GE48120X012	56	Pusher Post Pin Retaining Ring, Steel	GE33772X012
42	Upper Spring Retainer Token Relief (Low Flow), Zinc-plated steel Token Relief (Standard Flow), Zinc-plated steel Standard Relief (High Capacity Relief), Aluminum Low Start-to-Discharge for Standard Relief (High Capacity Relief), Aluminum	GE46956X012 GE46956X012 GE27059X012 GE27059X012	57	Spring Pin, Zinc-plated steel Token Relief (Low Flow) only	GE33668X012
43	Lower Spring Seat, Aluminum Non-relief Token Relief (Standard Flow) Token Relief (Low Flow) Standard Relief (High Capacity Relief) Low Start-to-Discharge for Standard Relief (High Capacity Relief)	GE27025X012 GE27025X012 GE27025X012 GE26111X012 GE26111X012	60	Closing Cap (Types CS800 and CS820 only), Aluminum Gray Red	GE26109X012 GE26109X022
44	Relief Valve Diaphragm Stem Token Relief (Low Flow), Zinc-plated steel Token Relief (Standard Flow), Zinc-plated steel Standard Relief (High Capacity Relief) Aluminum Low Start-to-Discharge for Standard Relief (High Capacity Relief), Aluminum	ERAA00767A0 ERAA00767A0 GE27058X012 GE27058X012	62*	O-ring, Nitrile (NBR)	GE29750X012
			65	Adjusting Screw For Types CS800 and CS820, Aluminum Spring ranges up to 2.5 psig / 170 mbar For Type CS820, Brass Spring ranges above 2.5 psig / 170 mbar For Type CS850, Zinc-plated steel	GE26108X012 GE47294X012 GE27026X012
			70	Body	See Table 3
			71	Bolt, Steel (4 required)	GE29974X012
			72	Pipe Plug Plated steel Stainless steel	1C333528992 1C3335X0012
			74	Blanking Plug, Aluminum For Ductile Iron and Steel Bodies, non-Overpressure Protection service only	GE31255X012
			75	O-ring, Nitrile (NBR) For Ductile Iron and Steel Bodies, non-Overpressure Protection service only	GF03442X012
			76	Half Flange (2 required), Steel For Ductile Iron and Steel Bodies, non-Overpressure Protection service only	GF01942X012
			77	O-ring, Nitrile (NBR) For Ductile Iron and Steel Bodies, non-Overpressure Protection service only	GF03443X012

*Recommended spare part

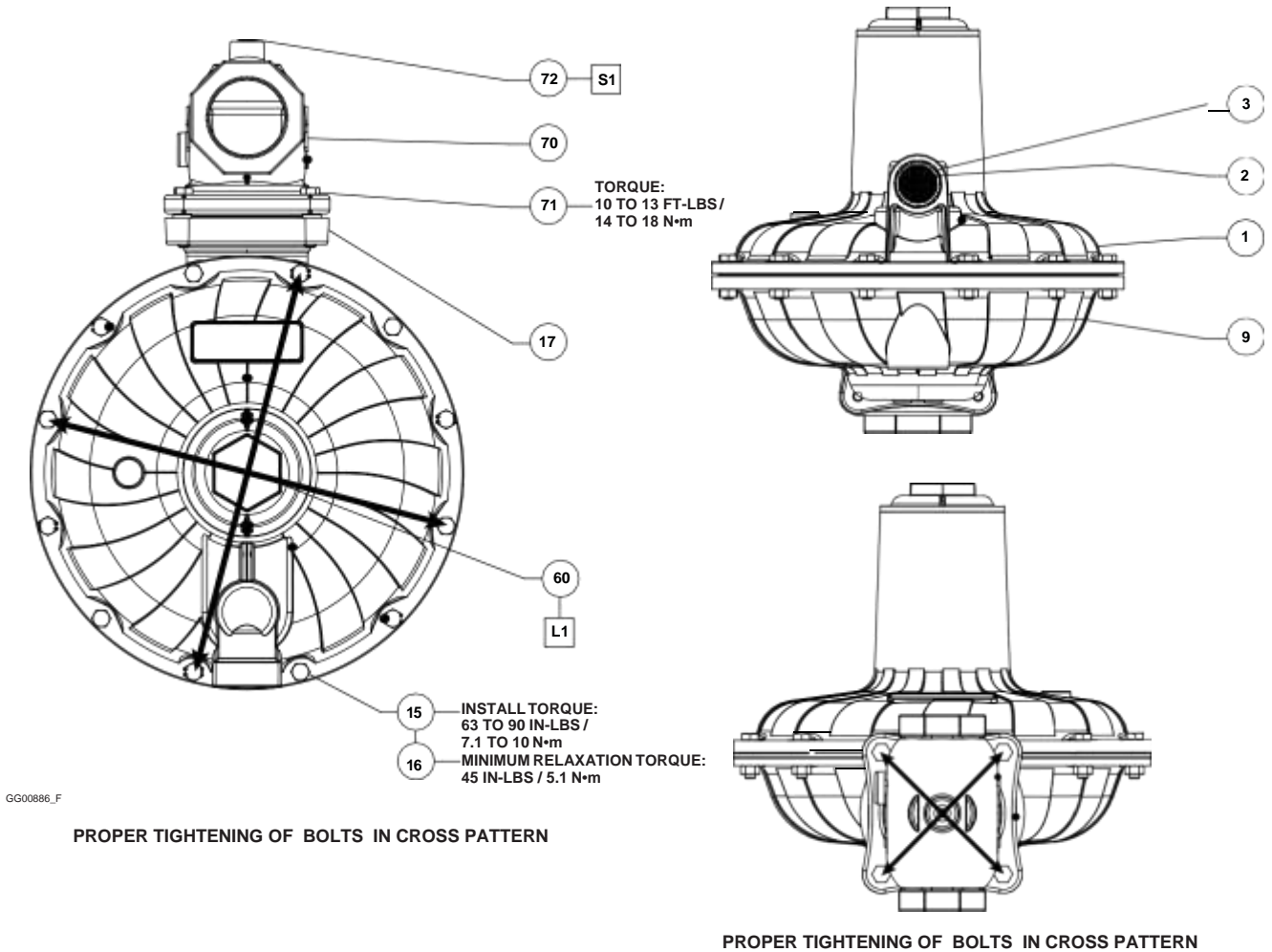

GG00886_F

APPLY LUBRICANT (L) / SEALANT (S)⁽¹⁾:
 L1 = ANTI-SEIZE LUBRICANT
 S1 = THREAD SEALANT WITH PTFE

1. Lubricant and sealant must be selected such that they meet the temperature requirements.

Figure 12. CS800 Series Regulator Assemblies

Key	Description	Part Number	Key	Description	Part Number
80	Screw (4 required), Steel For Ductile Iron and Steel Bodies, non-Overpressure Protection service only	GE38176X012	104	Bonnet, Zinc-plated steel Type CS850 only	GE26812X012
81	Spring Pin, Plated carbon steel For ductile iron and steel bodies not common to the Type CS804	GE32722X012	105	Upper Spring Seat, Zinc-plated carbon steel Type CS850 only	GE26809X012
81	Sense Tube For configurations with Slam-shut For configurations with True-Monitor™	ERAA02440A0 ERAA03562A0	106	Ball Bearing, Stainless steel Type CS850 only	GE33131X012
82*	O-ring, Nitrile (NBR)	GE30397X012	107	Locknut, Steel (Type CS850 only)	GE49038X012
90	Nameplate	-----	108	Stem Rivet, Stainless steel	GE45994X012
91	Warning Label	-----	109	Retaining Ring, Steel	GE33772X012
93	PED / EN 334 Information Label	-----	110	Pusher Post Nut, Zinc-plated steel Token Relief (Low Flow) only	GE46959X012
100	Lockwire, Stainless steel	T12315T0022	111	Pusher Post Retainer, Aluminum Token Relief (Low Flow) only	GE46957X012
103	Thrust Washer, CS820 Series 2.5 psig to 5.5 psig / 170 to 380 mbar spring only	GE47292X012	115	Diaphragm Stem O-ring, Nitrile (NBR) Token Relief (Low Flow) only	GE49041X012
			120	Stabilizer Cartridge	ERAA26894A0

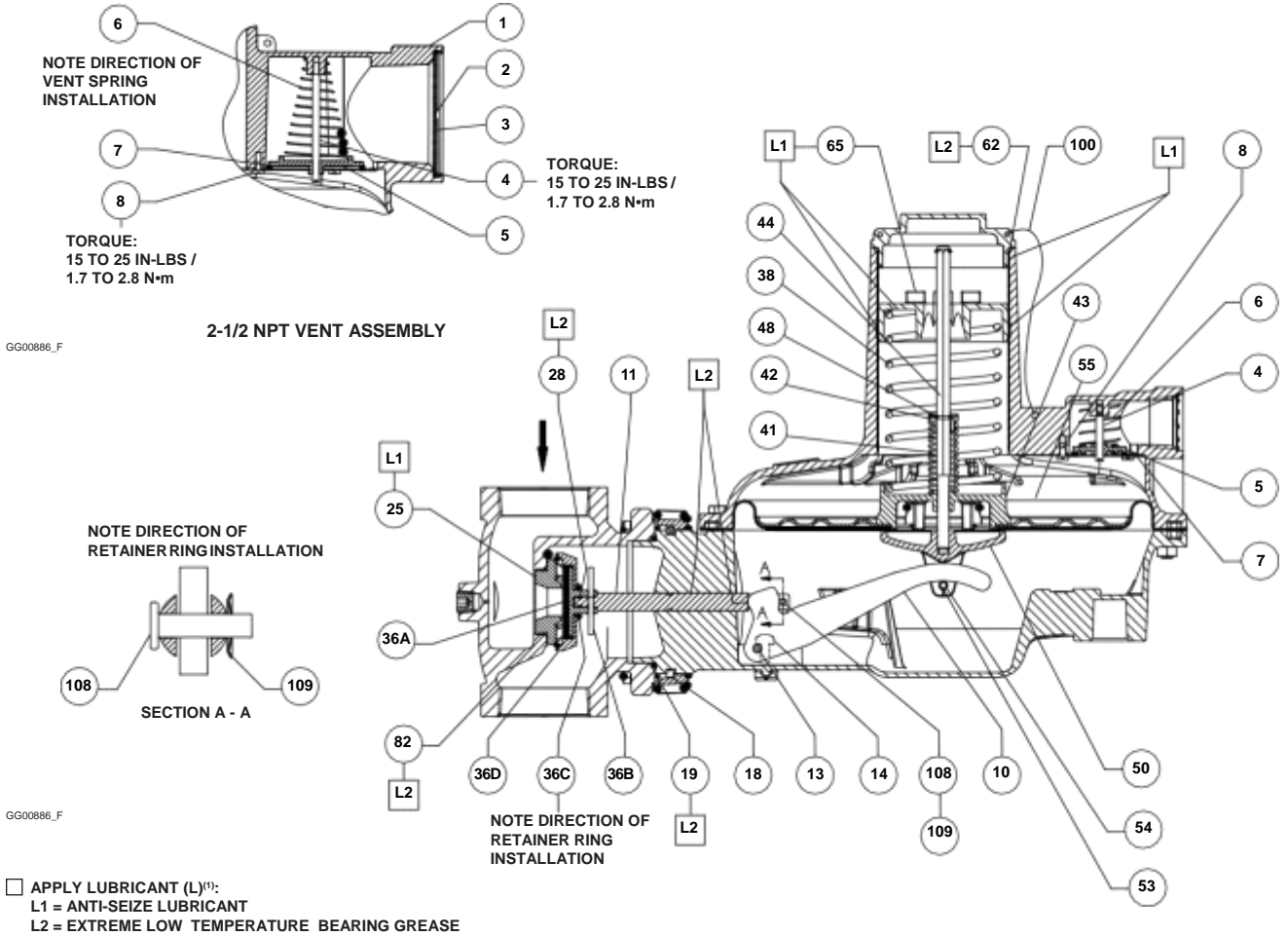

Figure 12. CS800 Series Regulator Assemblies (continued)

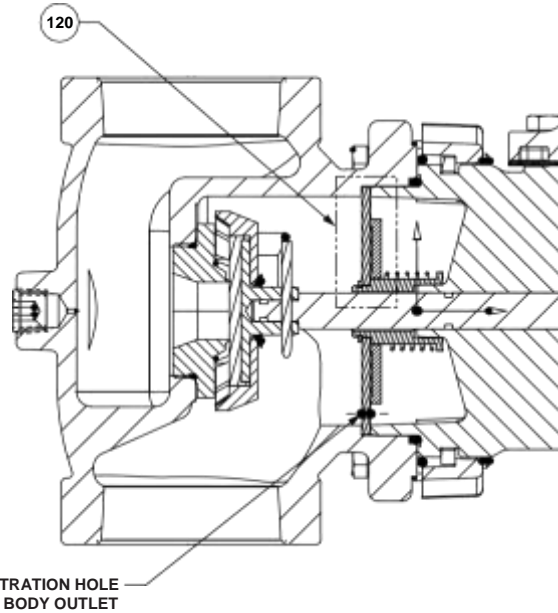
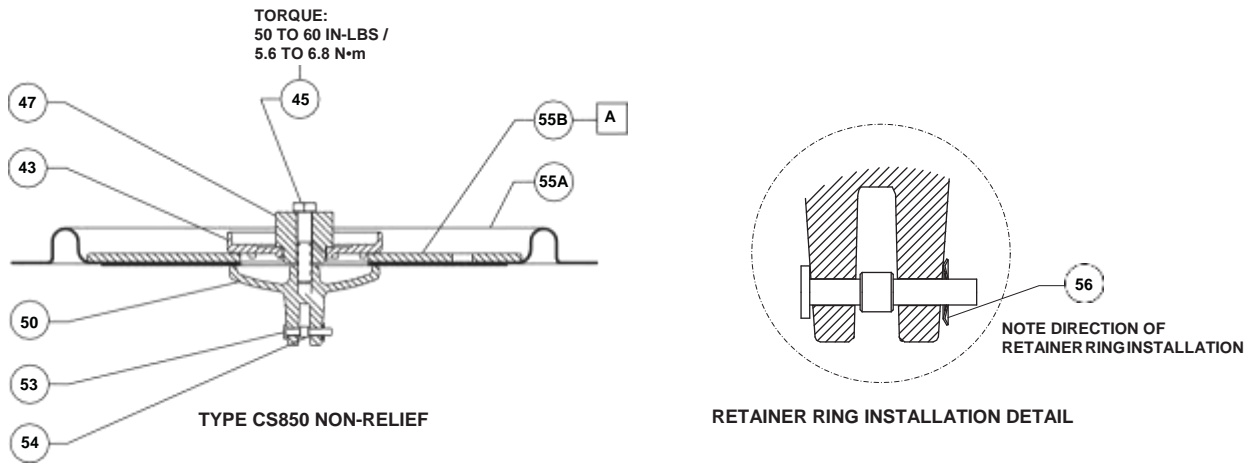
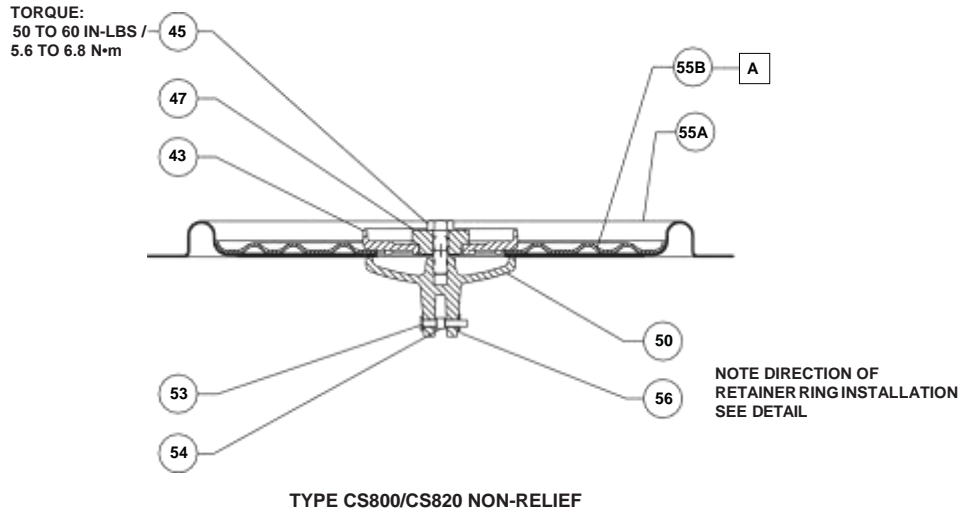

Figure 13. CS800 Series with Stabilizer Cartridge Assembly



GG00886_F

APPLY ADHESIVE (A)⁽¹⁾

NOTE: APPLY ADHESIVE ON THE FLAT SURFACE OF THE DIAPHRAGM PLATE THAT CONTACTS THE DIAPHRAGM, TOWARD THE OUTER PERIMETER, AND AWAY FROM THE CENTER HOLE.

1. Adhesive must be selected such that it meets the temperature requirements.

Figure 14. CS800 Series Diaphragm and Relief Assemblies

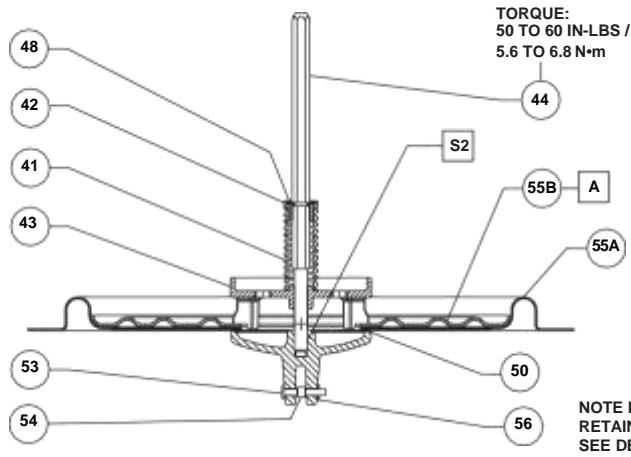

TYPE CS800/CS820 STANDARD/HIGH CAPACITY RELIEF

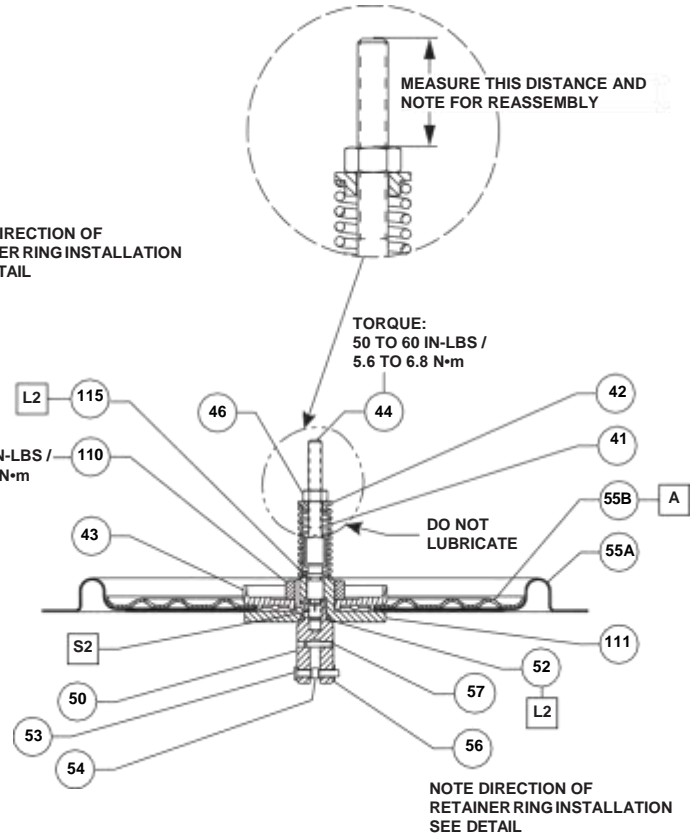

TYPE CS800/CS820 TOKEN RELIEF LOW FLOW

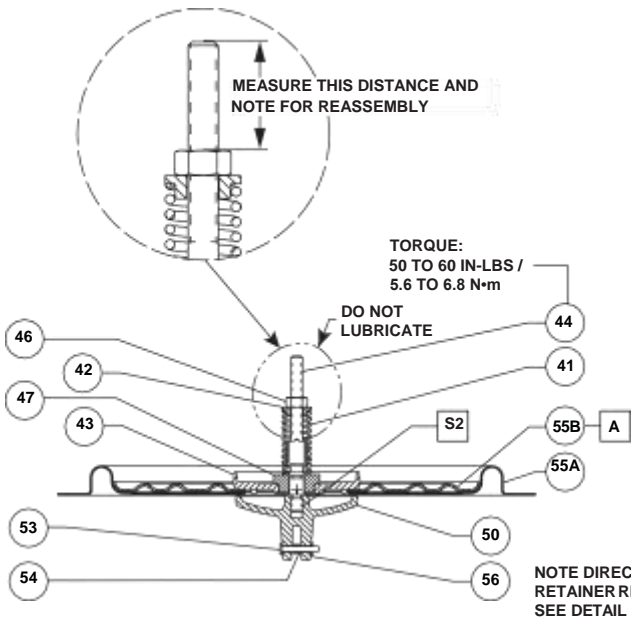

TYPE CS800/CS820 STANDARD FLOW TOKEN RELIEF

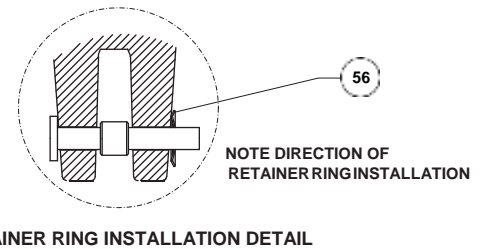

RETAINER RING INSTALLATION DETAIL

GG00886_F

- APPLY LUBRICANT (L) / SEALANT (S) / ADHESIVE (A)⁽¹⁾:
 L2 = EXTREME LOW TEMPERATURE BEARING GREASE
 S2 = MEDIUM STRENGTH THREADLOCKER SEALANT
 A = ADHESIVE

NOTE: APPLY ADHESIVE ON THE FLAT SURFACE OF THE DIAPHRAGM PLATE THAT CONTACTS THE DIAPHRAGM, TOWARD THE OUTER PERIMETER, AND AWAY FROM THE CENTER HOLE.

1. Lubricant, sealant and adhesive must be selected such that they meet the temperature requirements.

Figure 14. CS800 Series Diaphragm and Relief Assemblies (continued)

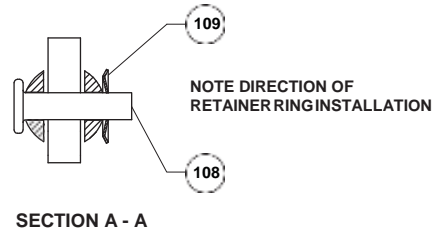
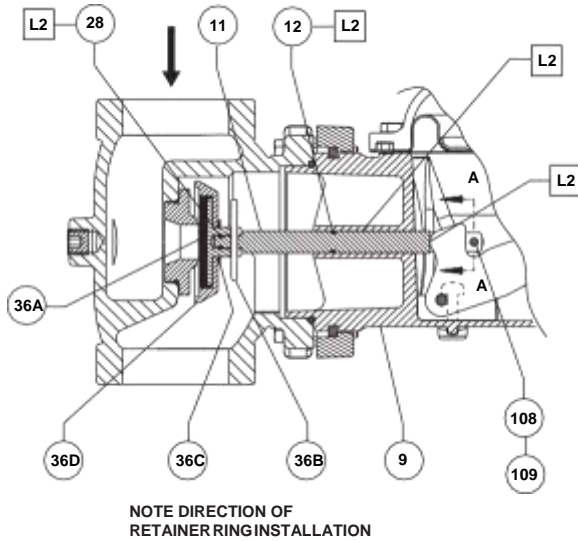

GG00886_F

- APPLY LUBRICANT (L)⁽¹⁾:
 L1 = ANTI-SEIZE LUBRICANT
 L2 = EXTREME LOW TEMPERATURE BEARING GREASE

1. Lubricants must be selected such that they meet the temperature requirements.

Figure 15. CS800 Series External Registration

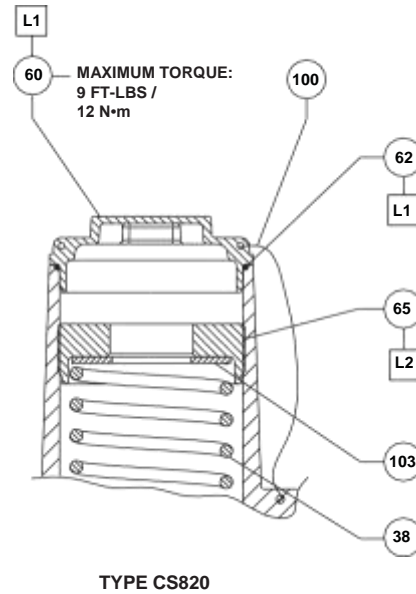
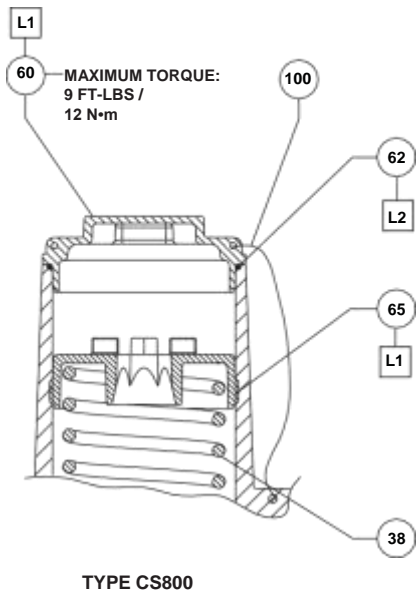

GG00886_F

- APPLY LUBRICANT (L)⁽¹⁾:
 L1 = ANTI-SEIZE LUBRICANT
 L2 = EXTREME LOW TEMPERATURE BEARING GREASE

1. Lubricants must be selected such that they meet the temperature requirements.

Figure 16. CS800 Series Control Spring Adjustment Assemblies

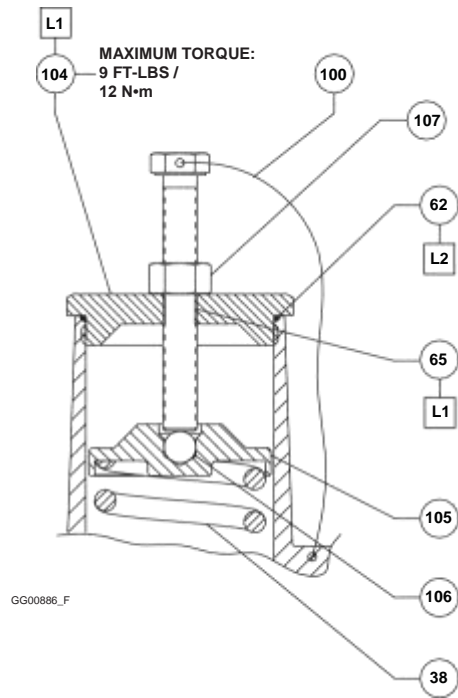

- APPLY LUBRICANT (L)⁽¹⁾:
- L1 = ANTI-SEIZE LUBRICANT
- L2 = EXTREME LOW TEMPERATURE BEARING GREASE

1. Lubricants must be selected such that they meet the temperature requirements.

Figure 16. CS800 Series Control Spring Adjustment Assemblies (continued)

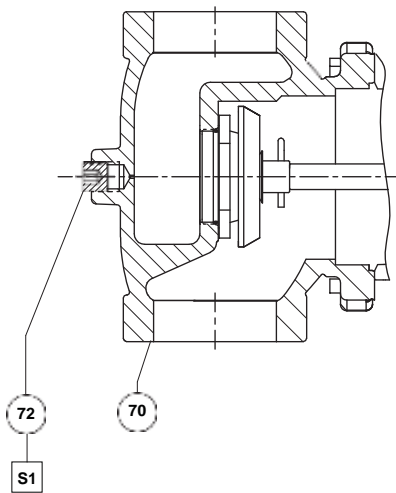

**GRAY CAST IRON BODIES
 WITHOUT OVERPRESSURE PROTECTION**

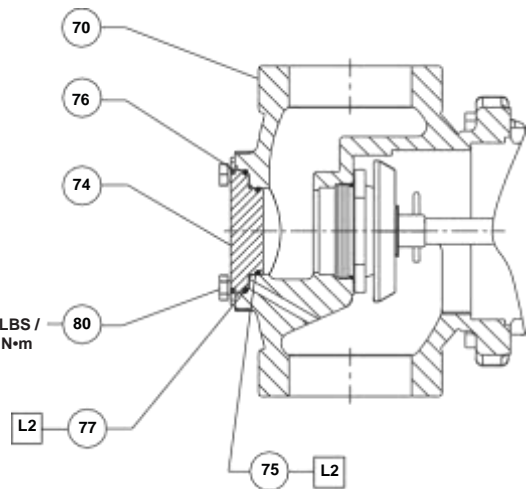

**GRAY CAST IRON/DUCTILE IRON/STEEL BODIES
 WITH OVERPRESSURE PROTECTION**

- APPLY LUBRICANT (L) / SEALANT (S)⁽¹⁾:
- L1 = ANTI-SEIZE LUBRICANT
- L2 = EXTREME LOW TEMPERATURE BEARING GREASE
- S1 = THREAD SEALANT WITH PTFE

1. Lubricants and sealants must be selected such that they meet the temperature requirements.

Figure 17. CS800 Series Body Configurations

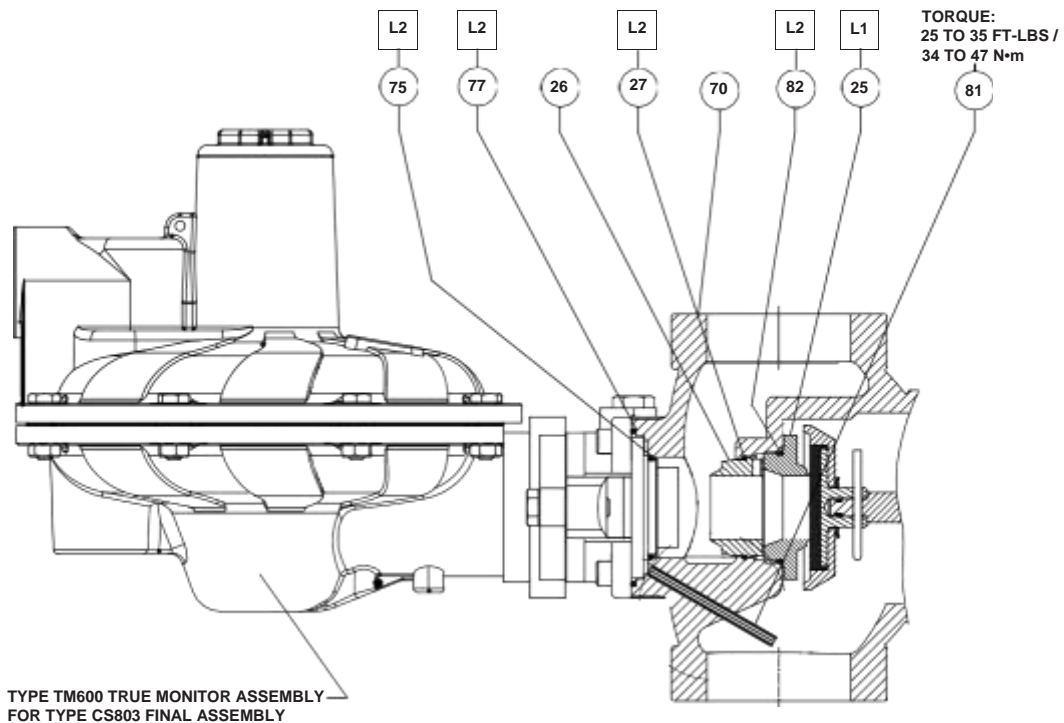
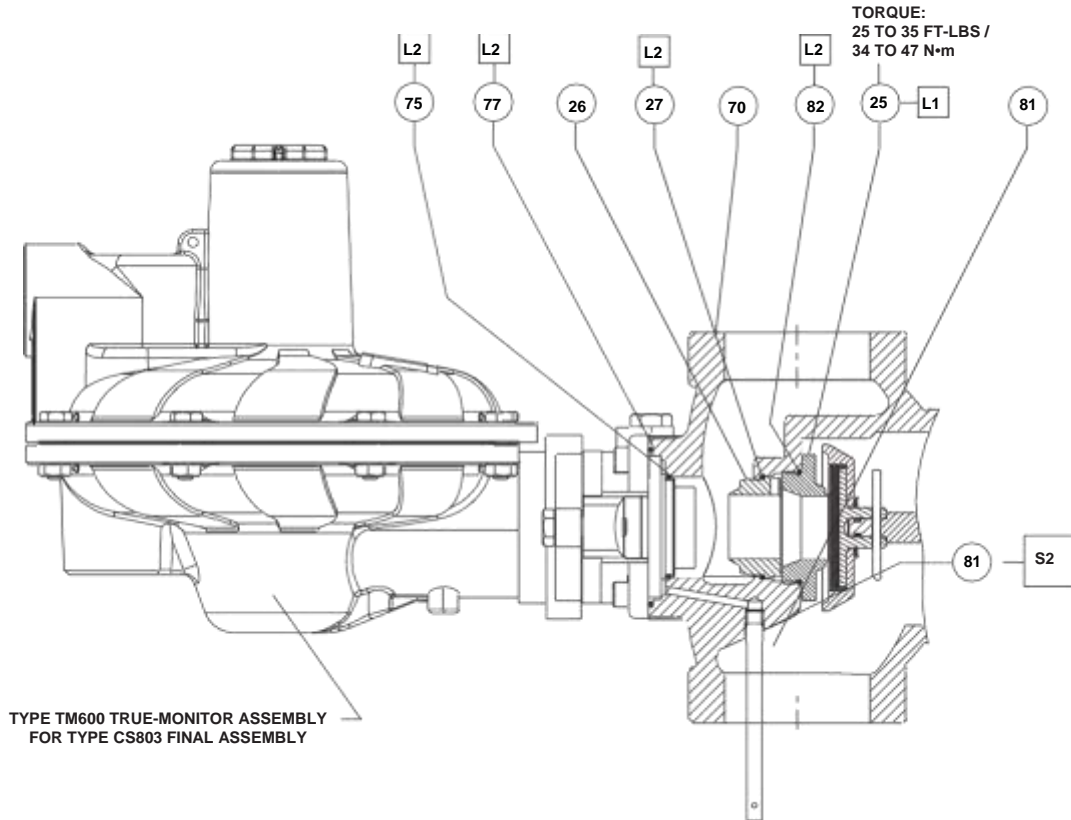

- APPLY LUBRICANT (L) / SEALANT (S)⁽¹⁾:
- L1 = ANTI-SEIZE LUBRICANT
 - L2 = EXTREME LOW TEMPERATURE BEARING GREASE
 - S2 = MEDIUM STRENGTH THREADLOCKER SEALANT

1. Lubricants and sealants must be selected such that they meet the temperature requirements.

Figure 18a. CS800 Series Integral True-Monitor™ Module and Orifice Assemblies

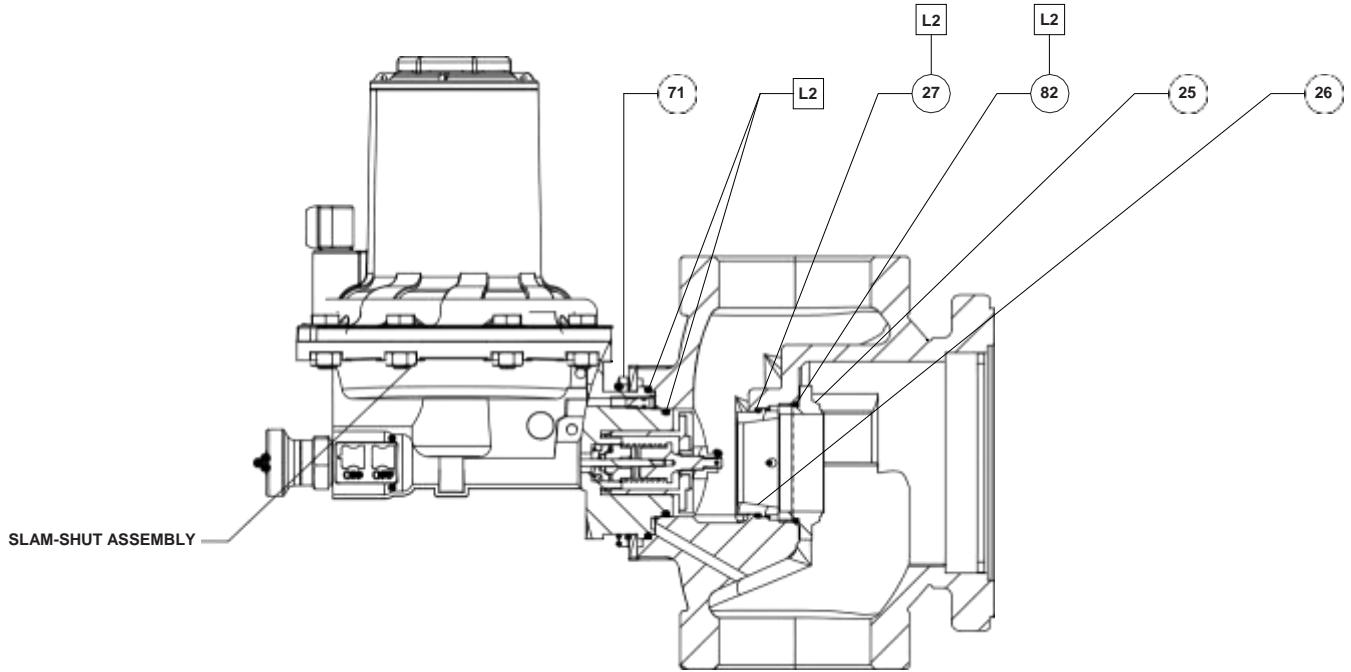

ORIFICE AND SLAM-SHUT ASSEMBLY

GE32407_AB

APPLY LUBRICANT⁽¹⁾:

L2 = EXTREME LOW-TEMPERATURE BEARING GREASE

1. Lubricants must be selected such that they meet the temperature requirements.

Figure 18b. CS800 Series Slam-shut Module and Orifice Assemblies (continued)

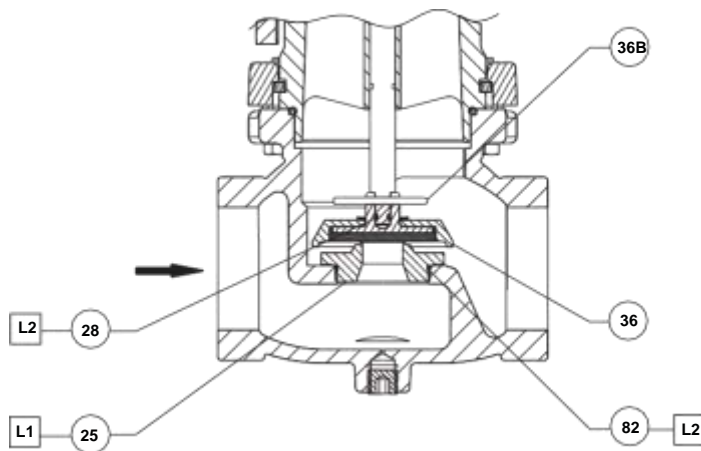

STANDARD ORIFICE AND STANDARD DISK ASSEMBLY

APPLY LUBRICANT (L) / SEALANT (S)⁽¹⁾:

L1 = ANTI-SEIZE LUBRICANT

L2 = EXTREME LOW TEMPERATURE BEARING GREASE

1. Lubricants and sealants must be selected such that they meet the temperature requirements.

Figure 19. CS800 Series Base Orifice and Secondary Seat™ (For Types CS805 and CS806) Assemblies

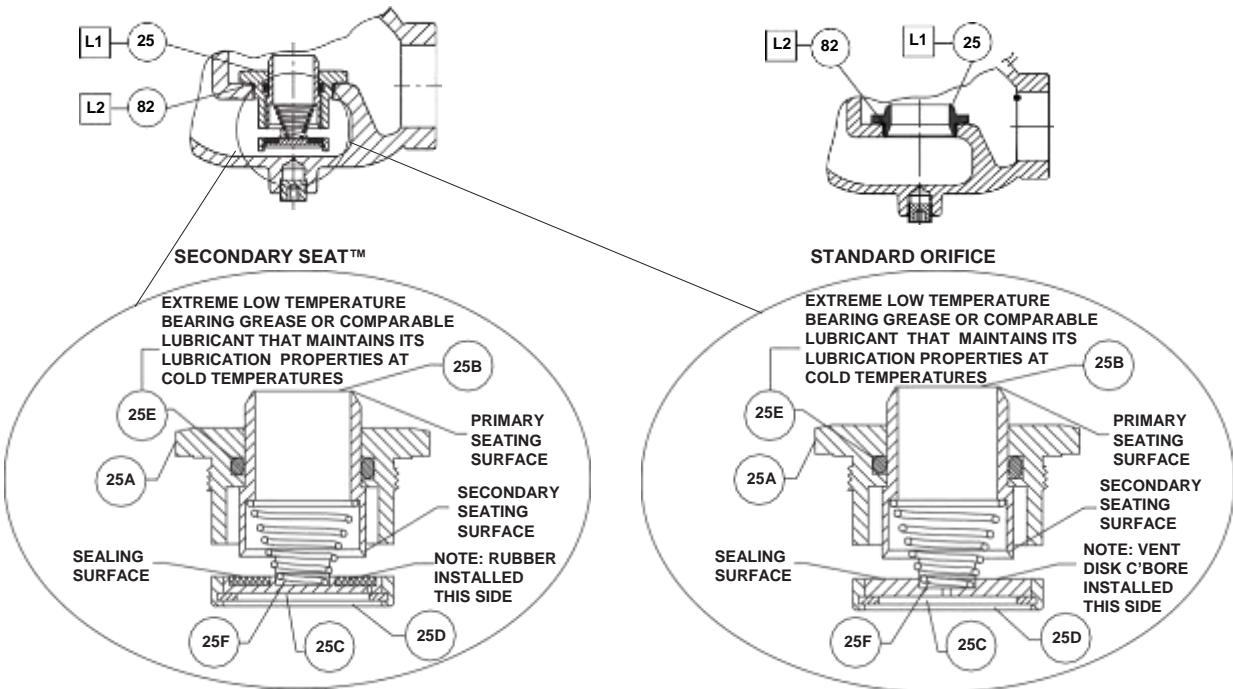

GG00886_F

TYPE CS805 SECONDARY SEAT ORIFICE ASSEMBLY (DETAILED VIEW)

TYPE CS806 SECONDARY SEAT ORIFICE ASSEMBLY (DETAILED VIEW)

APPLY LUBRICANT (L)⁽¹⁾:

L1 = ANTI-SEIZE LUBRICANT

L2 = EXTREME LOW TEMPERATURE BEARING GREASE

1. Lubricants must be selected such that they meet the temperature requirements.

Figure 19. CS800 Series Base Orifice and Secondary Seat (For Types CS805 and CS806) Assemblies (continued)

D103124X012 © 2010, 2020
 Emerson Process
 Management Regulator
 Technologies, Inc. All rights
 reserved. 06/20.
 The Emerson logo is a trademark and
 service mark of Emerson
 Electric Co. All other marks are
 the property of their prospective
 owners. Fisher™ is a mark
 owned by Fisher Controls

International LLC, a
 business of Emerson
 Automation Solutions.

The contents of this
 publication are presented
 for information purposes
 only, and while effort has
 been made to ensure their
 accuracy, they are not to
 be construed as
 warranties or guarantees.

express or implied, regarding the products or services described herein
 or their use or applicability. All sales are governed by our terms and
 conditions, which are available on request. We reserve the right to
 modify or improve the designs or specifications of our products at any
 time without notice.

Emerson Process Management Regulator Technologies, Inc. does not
 assume responsibility for the selection, use or maintenance of any
 product. Responsibility for proper selection, use and maintenance of any
 Emerson Process Management Regulator Technologies, Inc. product
 remains solely with the purchaser.



The distinctive swirl pattern cast into every actuator casing uniquely identifies the regulator as part of the Fisher™ brand Commercial Service Regulator family and assures you of the highest-quality engineering, performance, and support traditionally associated with Fisher™ and Tartarini™ regulators. Visit www.fishercommercialservice.com to access interactive applications.

