



October 2009

Types 627W and 627WH Direct-Operated Pressure Reducing Liquid Regulators

Introduction

The Types 627W and 627WH are direct-operated pressure reducing regulators for liquid service. They are available in NPS 3/4, 1, and 2 (DN 25 and 50) body sizes and in a wide range of materials of construction to match most service conditions.

A control line version is available in either the Type 627W or the Type 627WH (a higher pressure range unit). Both units are available with either internal or external downstream pressure registration. A control line is required for the external pressure registration version. The control line version has a blocked throat with an O-ring stem seal and a 1/4 NPT control line connection in the diaphragm case (Figure 2). The stem seal separates the body outlet pressure from the diaphragm case.

Features

- **Application Versatility**—The regulators can be used in nearly all liquid applications where constant downstream pressure is required.
- **Easy to Maintain**—Trim parts can be replaced without removing the regulator body from the pipeline. A two-bolt connection between the body and diaphragm casing simplifies disassembly for maintenance.
- **Tamper-Resistant**—An adjusting screw locknut and protective cap (Figure 1) are standard on all Type 627W regulators to discourage tampering with the pressure setting.
- **Tight Shutoff Capability**—A flat-faced disk of Nylon (PA) or various elastomers provides excellent shutoff capability.
- **Installation Adaptability**—The diaphragm case and/or regulator body can be rotated in any of four positions to allow regulator installation in locations with limited space. The regulator may be installed in any position without affecting operation as long as the spring case vent is protected from the elements.
- **Versatility**—The Types 627W and 627WH are available in six spring ranges, five disk materials, and three different body materials. The body is available in NPT, ASME flanged, and EN flanged constructions.



Figure 1. Type 627W Pressure Reducing Liquid Regulator

Principle of Operation

The Type 627W or 627WH (refer to Figure 2) is a direct-operated regulator. On the internal registration version, downstream pressure is registered internally through the body to the under side of the diaphragm. When the downstream pressure is at or above the set pressure, the disk is held against the seat, and there is no flow through the regulator. When demand increases, downstream pressure drops slightly allowing the spring to extend, moving the stem down and the disk away from the seat. This allows flow through the body to the downstream system.

Types 627W and 627WH direct-operated regulators are also available in a downstream control line version. This version has a stem seal between the body outlet pressure and diaphragm case. Pressure is registered under the diaphragm through the 1/4 NPT downstream control line connection (Figure 2).



Specifications

Available Constructions

Type 627W: Direct-operated pressure reducing liquid regulator (Figure 2).

Type 627WH: Type 627W with a diaphragm limiter to deliver a higher outlet pressure (Figure 2).

Control Line Option: Type 627W or 627WH with a stem seal between the body outlet pressure and diaphragm case. Pressure is measured under the diaphragm through the 1/4 NPT downstream control line connection (Figure 2).

Body Sizes and End Connection Styles

NPT: 3/4, 1, or 2

CL150, CL300, or CL600 RF Flanged:

NPS 1 or 2 (DN 25 or 50)

PN 16, 25, or 40: NPS 1 or 2 (DN 25 or 50)

Maximum Operating Inlet And Outlet Pressure Ranges⁽¹⁾

See Table 1 for pressures by orifice and spring range

Body Pressure Shell Rating⁽¹⁾

NPT (Steel): 2000 psig (138 bar)

NPT (Ductile Iron): 1000 psig (69,0 bar)

CL600 RF Flanged (Steel): 1500 psig (103 bar)

Maximum Spring And Diaphragm Casing Pressure⁽¹⁾

See Table 2

Orifice Sizes

1/4 or 1/2-inch (6,3 or 13 mm)

Regulator Capacities

Type 627W: See Table 4

Type 627WH: See Table 5

C_v Coefficients at 20% Proportional Band (Droop)

Type 627W: See Table 6

Type 627WH: See Table 7

Flow and Sizing Coefficients

See Table 8

Construction Materials

Body: Ductile iron, stainless steel, or steel

Spring Case: Stainless steel, steel, or ductile iron

Diaphragm Case: Ductile iron, stainless steel, or steel

O-Rings: Nitrile (NBR), Fluorocarbon (FKM), Ethylenepropylene (EPDM), or elastomeric Polytetrafluoroethylene (PTFE)

Diaphragm: Nitrile (NBR), Fluorocarbon (FKM), Ethylenepropylene (EPDM), or PTFE protector

Lever, Lever support, Orifice, and Stem guide: Stainless steel

Disk Holder with Valve Disk

Stainless steel with; Nylon (PA), Nitrile (NBR),

Fluorocarbon (FKM), or Ethylenepropylene (EPDM)

Temperature Capabilities⁽¹⁾

See Table 3

Pressure Registration

Type 627W or 627WH: Internal

Optional: External through 1/4 NPT control line connection in the diaphragm case

Spring Case Vent Connection

3/4 NPT with removable screened vent assembly

Approximate Weight

With Ductile Iron or Steel Casings:

10 pounds (5 kg)

External Dimensions

See Figure 4

Option

Outlet Pressure Gauge (Brass):

0 to 30 psi (0 to 2,1 bar); 0 to 60 psi (0 to 4,1 bar);

0 to 160 psi (0 to 11,0 bar); 0 to 300 psi (0 to 20,7 bar);

or 0 to 600 psi (0 to 41,4 bar)

1. The pressure/temperature limits in this Bulletin and any applicable standard or code limitation should not be exceeded.

Installation

Type 627W regulators may be installed in any position, as long as flow will be in the same direction as that indicated by the body arrow. The pressure and temperature limitations in the Specifications table must be observed and the downstream equipment protected from being overpressured.

Liquid pressure control systems should be designed using good engineering practices to eliminate quick starting or stopping of the flow stream, which can produce water hammer. The regulator should be installed so that the screened spring case vent is protected from anything that might clog it. To obtain the published capacities, the inlet and outlet piping should be the same as the regulator size.

A downstream control line is field installed with the control line version of the Type 627W or the Type 627WH.

Fisher® provides an instruction manual with every regulator shipped. Refer to this for complete installation, operation, and maintenance instructions. Included is a complete listing of individual parts and recommended spare parts.

Monitor Installation

One regulator (worker) is set at the desired downstream pressure. The other regulator (monitor) is set at a higher pressure and remains wide open. If the worker regulator fails open, the monitor regulator controls the downstream pressure at its setpoint. System lock-up pressure will be the monitor lock-up pressure (see Figure 3).

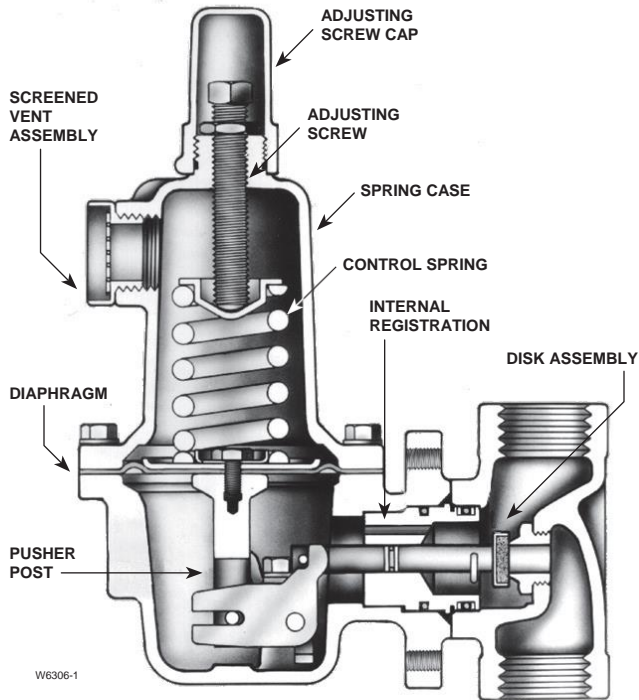

DETAILS OF TYPE 627W WITH INTERNAL DOWNSTREAM REGISTRATION

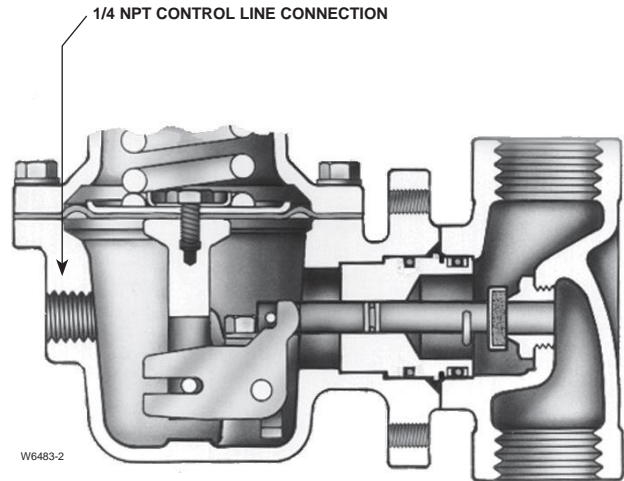

DETAIL OF TYPE 627W WITH EXTERNAL DOWNSTREAM PRESSURE REGISTRATION

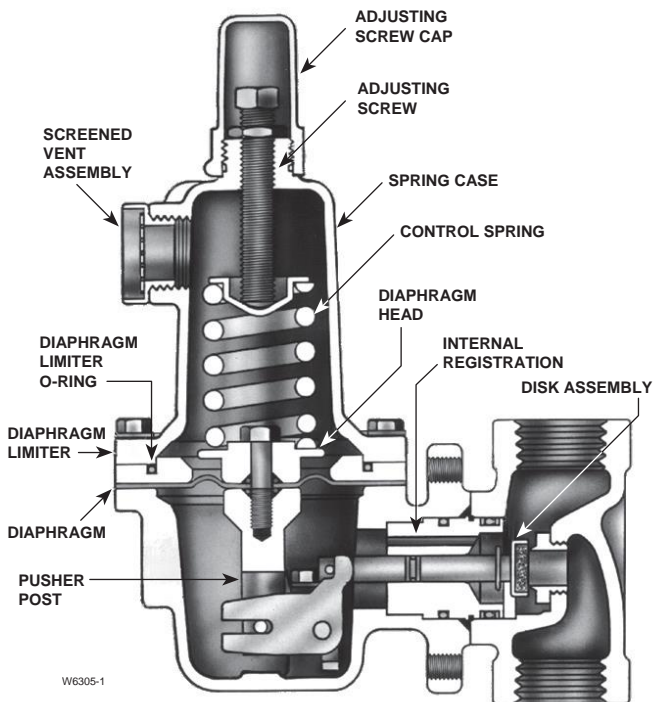

DETAILS OF TYPE 627WH WITH INTERNAL DOWNSTREAM REGISTRATION

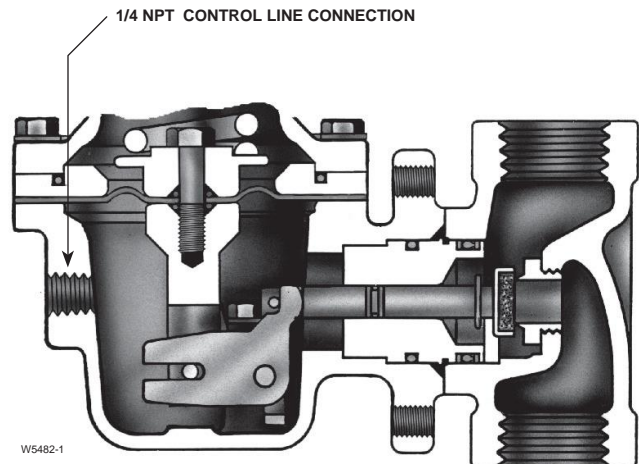

DETAIL OF TYPE 627WH WITH EXTERNAL DOWNSTREAM PRESSURE REGISTRATION

Figure 2. Types 627W and 627WH Construction Details



บริษัท เอดีดี เฟอร์เนส จำกัด

ADD FURNACE CO.,LTD.

44 ซอยบรมราชชนนี 70 ถนนบรมราชชนนี แขวงศาลาธรรมสพน์ เขตทวีวัฒนา กรุงเทพฯ 10170

โทร: 02-888-3472 โทร: ออกแบบ:08-08-170-170 แฟกซ์: 02-888-3258

https://www.add-furnace.com E-mail: sales@add-furnace.com

Table 1. Maximum Inlet Pressure, Differential Pressure, and Outlet Pressure Ranges

TYPE NUMBER	OUTLET PRESSURE RANGE CONTROL SPRING (COLOR)	ORIFICE SIZE, INCHES (mm)	MAXIMUM INLET PRESSURE, PSIG (bar)		MAXIMUM DIFFERENTIAL PRESSURE, PSID (bar d)	
			Elastomer Disk	Nylon (PA) Disk	Elastomer Disk	Nylon (PA) Disk
627W	10 to 20 psig (0,69 to 1,4 bar) 10B3076X012 (yellow)	1/4 (6,3)	220 (15,2)	420 (29,0)	200 (13,8)	400 (27,6)
		1/2 (13)	220 (15,2)	250 (17,2)	200 (13,8)	250 (17,2)
	15 to 40 psig (1,0 to 2,8 bar) 10B3077X012 (green)	1/4 (6,3)	240 (16,5)	440 (30,3)	200 (13,8)	400 (27,6)
		1/2 (13)	240 (16,5)	300 (20,7)	200 (13,8)	300 (20,7)
	35 to 80 psig (2,4 to 5,5 bar) 10B3078X012 (blue)	1/4 (6,3)	280 (19,3)	480 (33,1)	200 (13,8)	400 (27,6)
		1/2 (13)	280 (19,3)	480 (33,1)	200 (13,8)	400 (27,6)
70 to 150 psig (4,8 to 10,3 bar) 10B3079X012 (red)	1/4 (6,3)	350 (24,1)	550 (37,9)	200 (13,8)	400 (27,6)	
	1/2 (13)	350 (24,1)	550 (37,9)	200 (13,8)	400 (27,6)	
627WH	140 to 250 psig (9,6 to 17,2 bar) 10B3078X012 (blue)	1/4 (6,3)	450 (31,0)	650 (44,8)	200 (13,8)	400 (27,6)
		1/2 (13)	450 (31,0)	500 (34,5)	200 (13,8)	250 (17,2)
	240 to 500 psig (16,5 to 34,5 bar) 10B3079X012 (red)	1/4 (6,3)	700 (48,3)	900 (62,1)	200 (13,8)	400 (27,6)
		1/2 (13)	700 (48,3)	750 (51,7)	200 (13,8)	250 (17,2)

Table 2. Maximum Spring and Diaphragm Casing Pressure⁽¹⁾

MAXIMUM PRESSURE CONDITION	DIAPHRAGM CASING MATERIAL	TYPE 627W		TYPE 627WH	
		Psig	bar	Psig	bar
Maximum pressure to spring and diaphragm casings to prevent leak to atmosphere (internal parts damage may occur)	Ductile Iron	250	17,2	----	----
	Steel or Stainless Steel	250	17,2	800	55,2
Maximum pressure to spring and diaphragm casings to prevent burst of casings during abnormal operation (leak to atmosphere and internal parts damage may occur)	Ductile Iron	465	32,1	----	----
	Steel or Stainless Steel	1500	103	1500	103
Maximum diaphragm casing overpressure (above setpoint) to prevent damage to internal parts	All Materials	60	4,1	120	8,3

1. If the spring case is pressurized, a metal adjusting screw cap is required. Contact your local Sales Office for details.

Table 3. Elastomer Temperature Ranges

MATERIAL	DISK/DIAPHRAGM	TEMPERATURES		USAGE
		°F ⁽¹⁾	°C ⁽¹⁾	
Nitrile (NBR)	Disk	-40 to 180	-40 to 82	General
	Diaphragm			
Fluorocarbon (FKM)	Disk	0 to 300	-18 to 149	Not Recommended for Hot Water Service
	Diaphragm			
Ethylenepropylene (EPDM)	Disk	-40 to 275	-40 to 135	Not Recommended for Hydrocarbon Service
	Diaphragm			
Perfluoroelastomer (FFKM)	Disk	0 to 400	-18 to 204	Corrosive
Nylon (PA)	Disk	-40 to 200	-40 to 93	General
PTFE	Diaphragm Protector	-40 to 400	-40 to 204	Corrosive

1. Stainless steel body is rated to -40°F (-40°C). Steel and ductile iron bodies are rated to -20°F (-29°C).

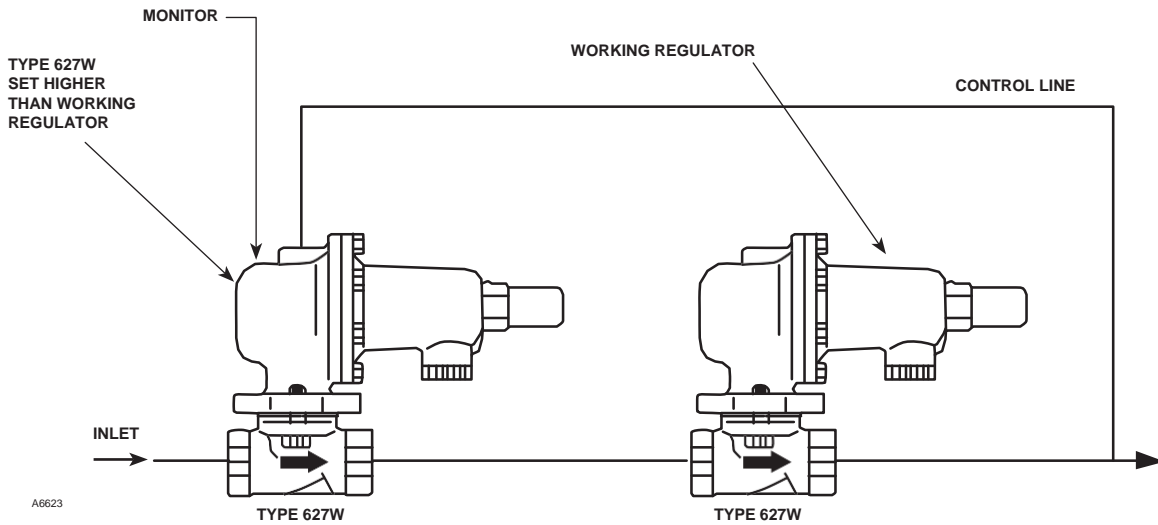

Figure 3. Monitor Regulator Schematic

Capacity Information

Tables 4 and 5 give regulating capacities in U.S. GPM of water (multiply by 0.2271 to convert to m³/h of water).

To determine regulating capacities at pressure settings not given in Tables 4 and 5 or to determine wide-open capacities for relief sizing at any inlet pressure, use the Catalog 10 liquid sizing procedures in conjunction with the appropriate liquid sizing coefficients (C_v and K_m, see Tables 6 through 8). Convert to m³/h according to the preceding paragraph if necessary.

$$Q = 1.18 \sqrt{\frac{120}{1.11}} = 12.2 \text{ GPM Glycol} \\ = 46.2 \text{ l/min Glycol}$$

Liquid Sizing for Liquids Other than Water

$$Q = C_v \sqrt{\frac{\Delta P}{G}}$$

where:

- Q = Flow in GPM
- ΔP = Value differential in psi
- C_v = Valve sizing coefficient (see Tables 6 and 7)
- G = Specific Gravity

Example:

NPS 1 (DN 25) body

1/4-inch (6,3 mm) orifice

Glycol (Specific Gravity) = 1.11

P_{inlet} = 200 psig (13,8 bar)

P_{out} (setpoint) = 100 psig (6,9 bar)

Capacity based on 20% Droop from setpoint

P_{out} at full flow = 100 psi setpoint – 20 psi Droop = 80 psi

ΔP = 200 – 80 = 120 psi

C_v = 1.18 from Table 6

Maximum Allowable Pressure Drop for Liquid Service

Pressure drops in excess of allowable will result in choked flow and possible cavitation damage.

Choked flow is the formation of vapor bubbles in the liquid flowstream causing a crowding condition at the vena contracta which tends to limit flow through the regulator. The vena contracta is the minimum cross-sectional area of the flow stream occurring just downstream of the actual physical restriction.

Cavitation and flashing are physical changes in the process fluid. The change is from the liquid state to the vapor state and results from the increase in fluid velocity at or just downstream of the greatest flow restriction, normally the regulator orifice.

To determine the maximum allowable pressure drop for water:

$$\Delta P_{(allow)} = K_m (P_1)$$

where:

- ΔP = Valve differential in psi
- K_m = Valve recovery coefficient from Table 8
- P₁ = Valve inlet pressure in psia

To determine maximum allowable pressure drop for fluids other than water, see Fisher® Catalog 10.



บริษัท เอดีดี เฟอร์เนส จำกัด

ADD FURNACE CO.,LTD.

44 ซอยบรมราชชนนี 70 ถนนบรมราชชนนี แขวงศาลาธรรมสพน์ เขตทวีวัฒนา กรุงเทพฯ 10170

โทร: 02-888-3472 โทร: ออกแบบ:08-08-170-170 แฟกซ์: 02-888-3258

https://www.add-furnace.com E-mail: sales@add-furnace.com

Table 4. Water Capacities⁽¹⁾ for the Type 627W Regulator in GPM (l/min) with or without a downstream control line

OUTLET PRESSURE RANGE AND CONTROL SPRING (COLOR)	OUTLET PRESSURE SETTING		INLET PRESSURE		NPS 3/4 BODY		NPS 1 (DN 25) BODY		NPS 2 (DN 50) BODY	
	Psig	bar	Psig	bar	1/4-Inch (6,3 mm) Orifice	1/2-Inch (13 mm) Orifice	1/4-Inch (6,3 mm) Orifice	1/2-Inch (13 mm) Orifice	1/4-Inch (6,3 mm) Orifice	1/2-Inch (13 mm) Orifice
10 to 20 psig (0,69 to 1,4 bar) 10B3076X012 (yellow)	10	0,69	15	1,0	2.9 (11,0)	6.9 (26,1)	2.9 (11,0)	7.0 (26,5)	3.0 (11,4)	7.0 (26,5)
			20	1,4	4.0 (15,1)	8.7 (32,9)	4.0 (15,1)	9.2 (34,8)	4.1 (15,5)	9.2 (34,8)
			30	2,1	5.4 (20,4)	13 (49,2)	6.0 (22,7)	13 (49,2)	6.0 (22,7)	13 (49,2)
			60	4,1	8.3 (31,4)	12 (45,4)	9.2 (34,8)	23 (87,1)	9.2 (34,8)	28 (106)
			75	5,2	9.4 (35,6)	12 (45,4)	10 (37,9)	23 (87,1)	10 (37,9)	33 (125)
			100	6,9	10 (37,9)	11 (41,6)	12 (45,4)	23 (87,1)	12 (45,4)	38 (144)
			150	10,3	10 (37,9)	10 (37,9)	15 (56,8)	22 (83,3)	15 (56,8)	29 (110)
			200	13,8	10 (37,9)	10 (37,9)	18 (68,1)	20 (75,7)	18 (68,1)	24 (90,8)
			300	20,7	10 (37,9)	10 (37,9)	22 (83,3)	---	22 (83,3)	---
	400	27,6	10 (37,9)	10 (37,9)	25 (94,6)	---	25 (94,6)	---		
	20	1,4	30	2,1	4.8 (18,2)	11 (41,6)	4.8 (18,2)	11 (41,6)	4.8 (18,2)	11 (41,6)
			50	3,4	7.4 (28,0)	14 (53,0)	7.4 (28,0)	20 (75,7)	7.4 (28,0)	20 (75,7)
			60	4,1	8.4 (31,8)	14 (53,0)	8.4 (31,8)	25 (94,6)	8.4 (31,8)	25 (94,6)
			100	6,9	12 (45,4)	17 (64,3)	12 (45,4)	32 (121)	12 (45,4)	32 (121)
			150	10,3	15 (56,8)	16 (60,6)	15 (56,8)	42 (159)	15 (56,8)	42 (159)
			200	13,8	15 (56,8)	16 (60,6)	17 (64,3)	43 (163)	17 (64,3)	43 (163)
			300	20,7	14 (53,0)	---	21 (79,5)	---	21 (79,5)	---
			400	27,6	12 (45,4)	---	25 (94,6)	---	25 (94,6)	---
15 to 40 psig (1,0 to 2,8 bar) 10B3077X012 (green)			40	2,8	60	4,1	6.7 (25,4)	13 (49,2)	6.7 (25,4)	14 (53,0)
	75	5,2			8.3 (31,4)	18 (68,1)	8.3 (31,4)	23 (87,1)	8.3 (31,4)	25 (94,6)
	100	6,9			11 (41,6)	19 (71,9)	11 (41,6)	28 (106)	11 (41,6)	31 (117)
	150	10,3			14 (53,0)	20 (75,7)	14 (53,0)	40 (151)	14 (53,0)	40 (151)
	200	13,8			16 (60,6)	19 (71,9)	16 (60,6)	49 (185)	16 (60,6)	49 (185)
	300	20,7			18 (68,1)	19 (71,9)	21 (79,5)	45 (170)	21 (79,5)	45 (170)
	400	27,6			20 (75,7)	---	24 (90,8)	60 (227)	24 (90,8)	---
	35 to 80 psig (2,4 to 5,5 bar) 10B3078X012 (blue)	60			4,1	75	5,2	6.4 (24,2)	19 (71,9)	6.4 (24,2)
100			6,9	9.2 (34,8)		20 (75,7)	9.2 (34,8)	23 (87,1)	9.2 (34,8)	24 (90,8)
150			10,3	13 (49,2)		24 (90,8)	13 (49,2)	36 (136)	13 (49,2)	36 (136)
200			13,8	16 (60,6)		26 (98,4)	16 (60,6)	42 (159)	16 (60,6)	51 (193)
300			20,7	20 (75,7)		25 (94,6)	20 (75,7)	60 (227)	20 (75,7)	60 (227)
400		27,6	22 (83,3)	23 (87,1)	22 (83,3)	60 (227)	22 (83,3)	66 (250)		
80		5,5	100	6,9	7.7 (29,1)	19 (71,9)	7.7 (29,1)	21 (79,5)	7.7 (29,1)	22 (83,3)
			150	10,3	12 (45,4)	20 (75,7)	12 (45,4)	35 (132)	12 (45,4)	41 (155)
			200	13,8	15 (56,8)	24 (90,8)	15 (56,8)	43 (163)	15 (56,8)	49 (185)
			300	20,7	20 (75,7)	26 (98,4)	20 (75,7)	60 (227)	20 (75,7)	60 (227)
	400		27,6	23 (87,1)	25 (94,6)	23 (87,1)	70 (265)	23 (87,1)	70 (265)	
70 to 150 psig (4,8 to 10,3 bar) 10B3079X012 (red)	100	6,9	150	10,3	9.4 (35,6)	20 (75,7)	9.6 (36,3)	24 (90,8)	9.6 (36,3)	24 (90,8)
			200	13,8	12 (45,4)	23 (87,1)	13 (49,2)	32 (121)	14 (53,0)	32 (121)
			300	20,7	19 (71,9)	25 (94,6)	19 (71,9)	44 (167)	19 (71,9)	50 (189)
			500	34,5	26 (98,4)	25 (94,6)	26 (98,4)	58 (220)	26 (98,4)	82 (310)
	125	8,6	150	10,3	9.0 (34,1)	19 (71,9)	9.0 (34,1)	19 (71,9)	9.0 (34,1)	22 (83,3)
			200	13,8	13 (49,2)	24 (90,8)	13 (49,2)	29 (110)	13 (49,2)	31 (117)
			300	20,7	18 (68,1)	29 (110)	18 (68,1)	42 (159)	18 (68,1)	49 (185)
			500	34,5	25 (94,6)	33 (125)	25 (94,6)	74 (280)	25 (94,6)	74 (280)
	150	10,3	200	13,8	11 (41,6)	25 (94,6)	11 (41,6)	28 (106)	11 (41,6)	31 (117)
			300	20,7	17 (64,3)	34 (129)	17 (64,3)	43 (163)	17 (64,3)	43 (163)
			400	27,6	25 (94,6)	37 (140)	25 (94,6)	73 (276)	25 (94,6)	73 (276)
			500	34,5	25 (94,6)	37 (140)	25 (94,6)	73 (276)	25 (94,6)	73 (276)

1. Water flow capacities based on a 20% proportional band.



บริษัท เอดีดี เฟอร์เนส จำกัด

ADD FURNACE CO.,LTD.

44 ซอยบรมราชชนนี 70 ถนนบรมราชชนนี แขวงศาลาธรรมสพน์ เขตทวีวัฒนา กรุงเทพฯ 10170

โทร: 02-888-3472 โทร: ออกแบบ:08-08-170-170 แฟกซ์: 02-888-3258

https://www.add-furnace.com E-mail: sales@add-furnace.com

Table 5. Water Capacities⁽¹⁾ for the Type 627WH Regulator in GPM (l/min) with or without a downstream control line

OUTLET PRESSURE RANGE AND CONTROL SPRING (COLOR)	OUTLET PRESSURE SETTING		INLET PRESSURE		NPS 3/4 BODY		NPS 1 (DN 25) BODY		NPS 2 (DN 50) BODY	
	Psig	bar	Psig	bar	1/4-Inch (6,3 mm) Orifice	1/2-Inch (13 mm) Orifice	1/4-Inch (6,3 mm) Orifice	1/2-Inch (13 mm) Orifice	1/4-Inch (6,3 mm) Orifice	1/2-Inch (13 mm) Orifice
140 to 250 psig (9,6 to 17,2 bar) 10B3078X012 (blue)	150	10,3	200	13,8	10 (37,9)	25 (94,6)	11 (41,6)	25 (94,6)	12 (45,4)	25 (94,6)
			250	17,2	14 (53,0)	31 (117)	14 (53,0)	31 (117)	14 (53,0)	31 (117)
			300	20,7	17 (64,3)	33 (125)	17 (64,3)	33 (125)	17 (64,3)	33 (125)
			400	27,6	20 (75,7)	34 (129)	21 (79,5)	34 (129)	21 (79,5)	34 (129)
			500	34,5	23 (87,1)	----	24 (90,8)	----	24 (90,8)	----
			550	37,9	24 (90,8)	----	25 (94,6)	----	25 (94,6)	----
	200	13,8	250	17,2	12 (45,4)	30 (114)	12 (45,4)	30 (114)	13 (49,2)	30 (114)
			300	20,7	15 (56,8)	36 (136)	16 (60,6)	36 (136)	16 (60,6)	36 (136)
			400	27,6	19 (71,9)	44 (167)	20 (75,7)	44 (167)	20 (75,7)	44 (167)
			500	34,5	22 (83,3)	----	22 (83,3)	----	23 (87,1)	----
			600	41,4	25 (94,6)	----	27 (102)	----	27 (102)	----
			650	44,8	27 (102)	----	27 (102)	----	27 (102)	----
250	17,2	300	20,7	13 (49,2)	35 (132)	13 (49,2)	51 (193)	13 (49,2)	51 (193)	
		400	27,6	18 (68,1)	46 (174)	18 (68,1)	52 (197)	18 (68,1)	52 (197)	
		500	34,5	22 (83,3)	51 (193)	23 (87,1)	58 (220)	22 (83,3)	58 (220)	
		650	44,8	27 (102)	----	27 (102)	----	27 (102)	----	
		700	48,3	27 (102)	----	27 (102)	----	27 (102)	----	
		750	51,7	27 (102)	----	27 (102)	----	27 (102)	----	
240 to 500 psig (16,5 to 34,5 bar) 10B3079X012 (red)	250	17,2	300	20,7	10 (37,9)	25 (94,6)	10 (37,9)	25 (94,6)	10 (37,9)	25 (94,6)
			400	27,6	15 (56,8)	30 (114)	16 (60,6)	32 (121)	16 (60,6)	32 (121)
			500	34,5	18 (68,1)	36 (136)	18 (68,1)	38 (144)	18 (68,1)	38 (144)
			650	44,8	20 (75,7)	----	20 (75,7)	----	20 (75,7)	----
	300	20,7	350	24,1	12 (45,4)	28 (106)	12 (45,4)	28 (106)	12 (45,4)	28 (106)
			400	27,6	15 (56,8)	31 (117)	16 (60,6)	32 (121)	16 (60,6)	32 (121)
			500	34,5	20 (75,7)	38 (144)	20 (75,7)	39 (148)	20 (75,7)	39 (148)
			700	48,3	27 (102)	----	27 (102)	----	27 (102)	----
	400	27,6	450	31,0	14 (53,0)	36 (136)	15 (56,8)	33 (125)	15 (56,8)	33 (125)
			500	34,5	18 (68,1)	41 (155)	19 (71,9)	42 (159)	19 (71,9)	42 (159)
			750	51,7	27 (102)	----	27 (102)	----	27 (102)	----
			800	55,2	28 (106)	----	28 (106)	----	28 (106)	----
	500	34,5	550	37,9	17 (64,3)	44 (167)	17 (64,3)	45 (170)	17 (64,3)	45 (170)
			600	41,4	19 (71,9)	50 (189)	20 (75,7)	51 (193)	20 (75,7)	51 (193)
			750	51,7	25 (94,6)	62 (235)	28 (106)	66 (250)	28 (106)	66 (250)
			900	62,1	27 (102)	----	28 (106)	----	28 (106)	----

1. Water flow capacities based on a 20% proportional band.



บริษัท เอดีดี เฟอร์เนส จำกัด

ADD FURNACE CO.,LTD.

44 ซอยบรมราชชนนี 70 ถนนบรมราชชนนี แขวงศาลาธรรมสพน์ เขตทวีวัฒนา กรุงเทพฯ 10170

โทร: 02-888-3472 โทร: ออกแบบ:08-08-170-170 แฟกซ์: 02-888-3258

https://www.add-furnace.com E-mail: sales@add-furnace.com

Table 6. C_v Coefficients⁽¹⁾ for the Type 627W Regulator with or without a downstream control line

OUTLET PRESSURE RANGE AND CONTROL SPRING (COLOR)	OUTLET PRESSURE SETTING		INLET PRESSURE		NPS 3/4 BODY		NPS 1 (DN 25) BODY		NPS 2 (DN 50) BODY	
	Psig	bar	Psig	bar	1/4-Inch (6,3 mm) Orifice	1/2-Inch (13 mm) Orifice	1/4-Inch (6,3 mm) Orifice	1/2-Inch (13 mm) Orifice	1/4-Inch (6,3 mm) Orifice	1/2-Inch (13 mm) Orifice
10 to 20 psig (0,69 to 1,4 bar) 10B3076X012 (yellow)	10	0,69	15	1,0	1.09	2.60	1.10	2.65	1.15	2.65
			20	1,4	1.14	2.51	1.15	2.64	1.19	2.64
			30	2,1	1.14	2.76	1.27	2.87	1.27	2.87
			60	4,1	1.14	1.64	1.27	3.22	1.27	3.28
			75	5,2	1.14	1.40	1.27	2.81	1.27	3.22
			100	6,9	1.06	1.12	1.27	2.41	1.27	3.20
			150	10,3	0.88	0.80	1.27	1.88	1.27	3.16
			200	13,8	0.68	0.70	1.27	1.49	1.27	3.15
			300	20,7	0.52	----	1.27	----	1.27	----
	400	27,6	0.50	----	1.27	----	1.27	----		
	20	1,4	30	2,1	1.27	2.96	1.27	3.03	1.27	3.03
			50	3,4	1.27	2.33	1.27	3.48	1.27	3.48
			60	4,1	1.27	2.06	1.27	3.50	1.27	3.50
			100	6,9	1.27	1.81	1.27	3.54	1.27	3.54
			150	10,3	1.27	1.28	1.27	3.59	1.27	3.59
			200	13,8	1.13	1.02	1.27	3.14	1.27	3.16
			300	20,7	0.84	----	1.27	----	1.27	----
			400	27,6	0.59	----	1.27	----	1.27	----
15 to 40 psig (1,0 to 2,8 bar) 10B3077X012 (green)			40	2,8	60	4,1	1.27	2.49	1.27	2.56
	75	5,2			1.27	2.76	1.27	3.48	1.27	3.89
	100	6,9			1.27	2.30	1.27	3.44	1.27	3.77
	150	10,3			1.27	1.82	1.27	3.66	1.27	3.66
	200	13,8			1.27	1.40	1.27	3.75	1.27	3.75
	300	20,7			1.19	1.18	1.27	3.68	1.27	3.68
	400	27,6			0.94	----	1.27	----	1.27	----
35 to 80 psig (2,4 to 5,5 bar) 10B3078X012 (blue)	60	4,1	75	5,2	1.22	3.61	1.25	3.61	1.25	3.61
			100	6,9	1.27	2.80	1.27	3.23	1.27	3.27
			150	10,3	1.27	2.37	1.27	3.56	1.27	3.59
			200	13,8	1.27	2.11	1.27	3.44	1.27	3.68
			300	20,7	1.27	1.55	1.27	3.60	1.27	3.60
	80	5,5	400	27,6	1.10	1.10	1.27	3.16	1.27	3.55
			100	6,9	1.27	3.17	1.27	3.48	1.27	3.72
			150	10,3	1.27	2.78	1.27	3.78	1.27	3.97
			200	13,8	1.27	2.31	1.27	3.66	1.27	3.78
			300	20,7	1.27	1.74	1.27	3.64	1.27	3.64
70 to 150 psig (4,8 to 10,3 bar) 10B3079X012 (red)	100	6,90	150	10,3	1.12	2.32	1.15	2.85	1.15	2.85
			200	13,8	1.14	2.10	1.18	2.90	1.18	2.90
			300	20,7	1.27	1.67	1.27	2.97	1.27	3.07
			500	34,5	1.27	1.23	1.27	2.82	1.27	3.58
	125	8,6	150	10,3	1.27	2.69	1.27	2.75	1.27	3.08
			200	13,8	1.27	2.45	1.27	2.91	1.27	3.05
			300	20,7	1.27	2.04	1.27	2.98	1.27	3.14
			500	34,5	1.27	1.64	1.27	3.68	1.27	3.68
			200	13,8	1.27	2.81	1.27	3.18	1.27	3.47
150	10,3	300	20,7	1.27	2.54	1.27	3.22	1.27	3.22	
		500	34,5	1.27	1.90	1.27	3.76	1.27	3.76	

1. C_v Coefficients based on a 20% proportional band.



บริษัท เอดีดี เฟอร์เนส จำกัด

ADD FURNACE CO.,LTD.

44 ซอยบรมราชชนนี 70 ถนนบรมราชชนนี แขวงศาลาธรรมสพน์ เขตทวีวัฒนา กรุงเทพฯ 10170

โทร: 02-888-3472 โทร: ออกแบบ:08-08-170-170 แฟกซ์: 02-888-3258

https://www.add-furnace.com E-mail: sales@add-furnace.com

Table 7. C_v Coefficients ⁽¹⁾for the Type 627WH Regulator with or without a downstream control line

OUTLET PRESSURE RANGE AND CONTROL SPRING (COLOR)	OUTLET PRESSURE SETTING		INLET PRESSURE		NPS 3/4 BODY		NPS 1 (DN 25) BODY		NPS 2 (DN 50) BODY	
	Psig	bar	Psig	bar	1/4-Inch (6,3 mm) Orifice	1/2-Inch (13 mm) Orifice	1/4-Inch (6,3 mm) Orifice	1/2-Inch (13 mm) Orifice	1/4-Inch (6,3 mm) Orifice	1/2-Inch (13 mm) Orifice
140 to 250 psig (9,6 to 17,2 bar) 10B3078X012 (blue)	150	10,3	200	13,8	1.17	2.83	1.20	2.83	1.26	2.83
			250	17,2	1.20	2.71	1.24	2.71	1.24	2.71
			300	20,7	1.25	2.51	1.30	2.51	1.30	2.51
			400	27,6	1.20	2.01	1.27	2.01	1.27	2.01
			500	34,5	1.17	----	1.23	----	1.23	----
	550	37,9	1.17	----	1.23	----	1.23	----		
	200	13,8	250	17,2	1.26	3.14	1.30	3.14	1.34	3.14
			300	20,7	1.30	3.05	1.34	3.05	1.34	3.05
			400	27,6	1.25	2.80	1.27	2.80	1.27	2.80
500			34,5	1.22	----	1.27	----	1.27	----	
600	41,4	1.22	----	1.27	----	1.27	----			
250	17,2	300	20,7	1.27	3.46	1.27	5.10	1.32	5.10	
		400	27,6	1.27	3.25	1.27	3.68	1.28	3.68	
		500	34,5	1.27	2.92	1.27	3.33	1.28	3.33	
		650	44,8	1.27	----	1.27	----	1.28	----	
240 to 500 psig (16,5 to 34,5 bar) 10B3079X012 (red)	250	17,2	300	20,7	1.00	2.46	1.03	2.52	1.03	2.52
			400	27,6	1.07	2.15	1.10	2.23	1.10	2.23
			500	34,5	1.02	2.08	1.02	2.17	1.02	2.17
			650	44,8	1.02	----	1.02	----	1.02	----
	300	20,7	350	24,1	1.17	2.63	1.18	2.69	1.18	2.69
			400	27,6	1.22	2.45	1.25	2.52	1.25	2.52
			500	34,5	1.27	2.33	1.27	2.45	1.27	2.45
			700	48,3	1.27	----	1.27	----	1.27	----
	400	27,6	450	31,0	1.27	3.16	1.29	3.23	1.29	3.23
			500	34,5	1.38	3.02	1.40	3.10	1.40	3.10
			750	51,7	1.28	----	1.28	----	1.28	----
			800	55,2	1.28	----	1.28	----	1.28	----
	500	34,5	550	37,9	1.40	3.57	1.42	3.64	1.42	3.64
			600	41,4	1.36	3.51	1.38	3.60	1.38	3.60
			750	51,7	1.34	3.50	1.38	3.50	1.38	3.50
			900	62,1	1.34	----	1.38	----	1.38	----

1. C_v Coefficients based on a 20% proportional band.

Table 8. Flow and Sizing Coefficients

BODY SIZE, NPS (DN)	ORIFICE SIZE, INCHES (mm)										
	Wide-Open C _v For Relief Sizing		K _m		IEC Sizing Coefficients						
	1/4 (6,3)	1/2 (13)	1/4 (6,3)	1/2 (13)	X _T		F _D		F _L		
				1/4 (6,3)	1/2 (13)	1/4 (6,3)	1/2 (13)	1/4 (6,3)	1/2 (13)		
3/4	1.63	4.87	0.76	0.74	0.592	0.962	0.50	0.50	0.87	0.86	
1 (25)	1.70	5.29			0.543	0.815					
2 (50)	1.66	5.01			0.620	1.01					



บริษัท เอดีดี เฟอร์เนส จำกัด

ADD FURNACE CO.,LTD.

44 ซอยบรมราชชนนี 70 ถนนบรมราชชนนี แขวงศาลาธรรมสพน์ เขตทวีวัฒนา กรุงเทพฯ 10170

โทร: 02-888-3472 โทร: ออกแบบ:08-08-170-170 แฟกซ์: 02-888-3258

https://www.add-furnace.com E-mail: sales@add-furnace.com

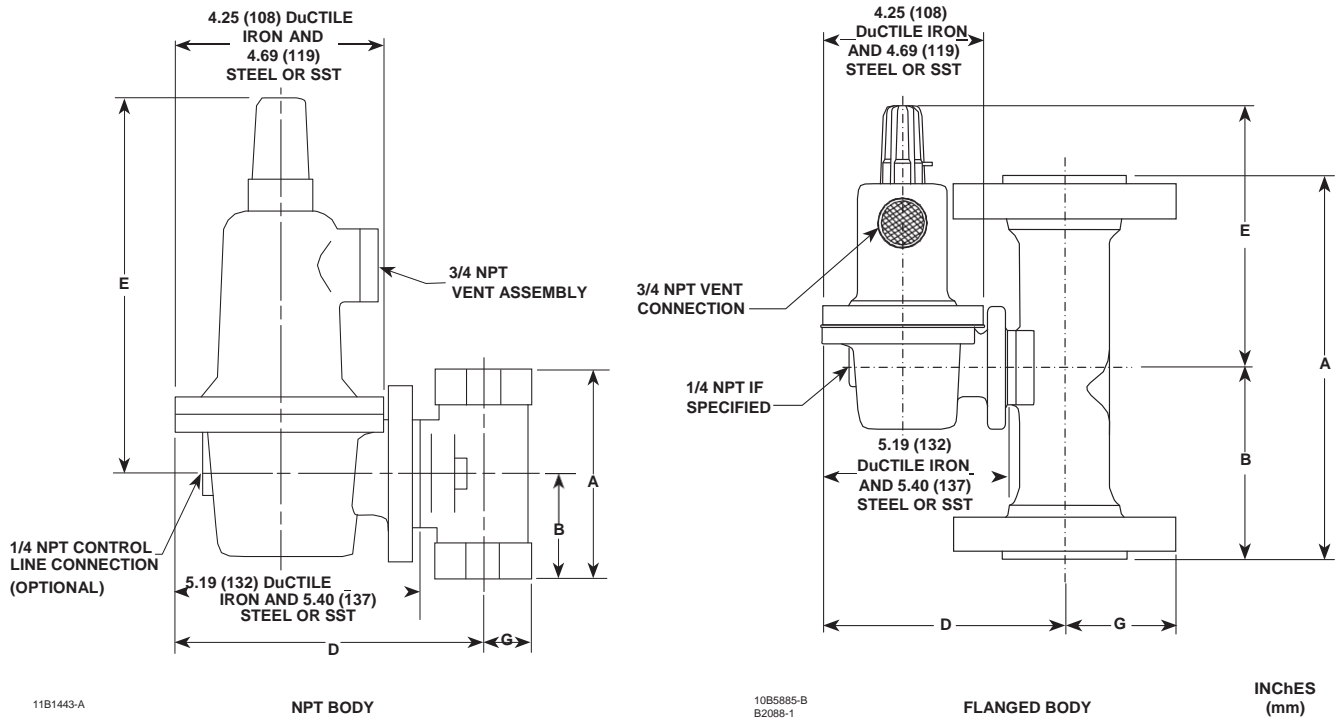

TYPE 627W						
Body Sizes, NPS (DN)	Dimensions, Inches (mm)					
	A	B	D		E	G
			Ductile Iron	Steel or SST		
3/4, 1 (25)	4.06 (103)	1.94 (49)	6.50 (165)	6.75 (171)	9.45 (240)	1.00 (25)
2 (50)	5.00 (127)	2.50 (63)	6.88 (175)	7.12 (181)	10.12 (257)	1.69 (43)

TYPE 627WH					
Body Sizes, NPS (DN)	Dimensions, Inches (mm)				
	A	B	D	E	G
3/4, 1 (25)	4.06 (103)	1.94 (49)	6.75 (171)	9.88 (251)	1.00 (25)
2 (50)	5.00 (127)	2.50 (63)	7.12 (181)	10.44 (265)	1.69 (43)

TYPE 627W														
Flanged Body														
Dimensions, Inches (mm)														
Body Size, NPS (DN)	A				B				D	E	G			
	CL150 RF	CL300 RF	CL600 RF	PN 16/25/40	CL150 RF	CL300 RF	CL600 RF	PN 16/25/40			CL150 RF	CL300 RF	CL600 RF	PN 16/25/40
1 (25)	7.25 (184)	7.75 (197)	8.25 (210)	7.80 (198)	3.62 (92)	3.88 (99)	4.12 (105)	3.90 (99)	6.75 (172)	7.62 (194)	2.12 (54)	2.44 (62)	2.44 (62)	2.27 (58)
2 (50)	10.00 (254)	10.50 (267)	11.25 (286)	10.31 (262)	5.00 (127)	5.25 (133)	5.62 (143)	5.16 (131)	7.12 (181)		3.00 (76)	3.25 (82)	3.25 (82)	3.25 (82)

Figure 4. Dimensions



TYPE 627WH													
Flanged Body													
Dimensions, Inches (mm)													
Body Size, NPS (DN)	A			B				D	E	G			
	CL150 RF	CL300 RF	CL600 RF	CL150 RF	CL300 RF	CL600 RF	PN 16/25/40			CL150 RF	CL300 RF	CL600 RF	PN 16/25/40
1 (25)	7.25 (184)	7.75 (197)	8.25 (210)	3.62 (92)	3.88 (99)	4.12 (105)	3.81 (97)	6.75 (172)	7.94 (202)	2.12 (54)	2.44 (62)	2.44 (62)	2.27 (58)
2 (50)	10.00 (254)	10.50 (267)	11.25 (286)	5.00 (127)	5.25 (133)	5.62 (143)	5.16 (131)	7.12 (181)		3.00 (76)	3.25 (82)	3.25 (82)	3.25 (82)

Figure 4. Dimensions (continued)

Ordering Information

Application

When ordering, specify:

1. Type of regulator
2. Body size
3. Body material and trim material
4. Orifice diameter in inches (mm)
5. Control spring range in psig (bar)
6. Maximum temperature of process fluid
7. Desired options

Construction

Refer to the Specifications section and to each referenced table; specify the desired selection whenever there is a choice to be made. The standard assembly position is shown in Figure 1, but an alternate assembly position may be factory-ordered or can be accomplished in the field by unbolting the body or spring case using the instructions in the appropriate section of the instruction manual. For dimensions refer to Figure 4.

Ordering Guide

Type (Select One)

- 627W
 627WH (high pressure)

Body Size (Select One)

- 3/4 NPT***
 NPS 1 (DN 25)***
 NPS 2 (DN 50)*

Body Material and End Connection Style (Select One)

Ductile Iron (Type 627W Only)

- NPT***

WCC Steel

- NPT***
 CL150 RF**
 CL300 RF***
 CL600 RF***
 PN 16/25/40*

CF8M Stainless Steel

- NPT **
 CL150 RF*
 CL300 RF*
 CL600 RF*
 PN 16/25/40*

Orifice Size (Select One)

- 1/4-inch (6,3 mm)***
 1/2-inch (13 mm)***

Spring Case Material (Select One)

- Ductile iron (**standard** for ductile iron body)***
 WCC Steel (**standard** for steel bodies)***
 CF8M Stainless steel (**standard** for stainless steel bodies)**

Diaphragm Case Material (Select One)

- Ductile iron (**standard** for ductile iron body)***
 WCC Steel (**standard** for steel bodies)***
 CF8M Stainless steel (**standard** for stainless steel bodies)**

Diaphragm (Select One)

- Nitrile (NBR) (**standard**)***
 Fluorocarbon (FKM) - water limited to 180°F (82°C)**
 Ethylenepropylene (EPDM)**

O-rings (Select One)

- Nitrile (NBR) (**standard**)***
 Fluorocarbon (FKM) - water limited to 180°F (82°C)**
 Ethylenepropylene (EPDM)**
 Perfluoroelastomer (FFKM)**



บริษัท เอดีดี เฟอร์เนส จำกัด

ADD FURNACE CO.,LTD.

44 ซอยบรมราชชนนี 70 ถนนบรมราชชนนี แขวงศาลาธรรมสพน์ เขตทวีวัฒนา กรุงเทพฯ 10170

โทร: 02-888-3472 โทร: ออกแบบ:08-08-170-170 แฟกซ์: 02-888-3258

https://www.add-furnace.com E-mail: sales@add-furnace.com

Ordering Guide (continued)

Valve Disk (Select One)

- Nitrile (NBR) (standard)***
- Nylon (PA)***
- Fluorocarbon (FKM) - water limited to 180°F (82°C)**
- Ethylenepropylene (EPDM)**

Spring Range (Select One)

Type 627W

- 10 to 20 psig (0,69 to 1,4 bar)***
- 15 to 40 psig (1,0 to 2,8 bar)***
- 35 to 80 psig (2,4 to 5,5 bar)***
- 70 to 150 psig (4,8 to 10,3 bar)***

Type 627WH

- 140 to 250 psig (9,7 to 17,2 bar)***
- 240 to 500 psig (16,5 to 34,5 bar)***

PTFE Diaphragm Protector (Optional)

- Yes

Pressure Registration (Select One)

- Internal***
- External***

Regulators Quick Order Guide	
***	Readily Available for Shipment
**	Allow Additional Time for Shipment
*	Special Order, Constructed from Non-Stocked Parts. Consult your local Sales Office for Availability.
Availability of the product being ordered is determined by the component with the longest shipping time for the requested construction.	

Specification Worksheet

Application:
 Specific Use _____
 Line Size _____
 Fluid Type _____
 Specific Gravity _____
 Temperature _____
 Does the Application Require Overpressure Protection?
 Yes No

Pressure:
 Maximum Inlet Pressure _____
 Minimum Inlet Pressure _____
 Differential Pressure _____
 Set Pressure _____
 Maximum Flow _____

Accuracy Requirements:
 Less Than or Equal To:
 5% 10% 20% 40%

Construction Material Requirements (if known):

For further information visit www.fisherregulators.com

The Emerson logo is a trademark and service mark of Emerson Electric Co. All other marks are the property of their prospective owners. Fisher is a mark owned by Fisher Controls, Inc., a business of Emerson Process Management.

The contents of this publication are presented for informational purposes only, and while every effort has been made to ensure their accuracy, they are not to be construed as warranties or guarantees, express or implied, regarding the products or services described herein or their use or applicability. We reserve the right to modify or improve the designs or specifications of such products at any time without notice.

Emerson Process Management does not assume responsibility for the selection, use or maintenance of any product. Responsibility for proper selection, use and maintenance of any Emerson Process Management product remains solely with the purchaser.

