



บริษัท เอดีดี เฟอร์เนส จำกัด

ADD FURNACE CO.,LTD.

44 ซอยบรมราชชนนี 70 ถนนบรมราชชนนี แขวงศาลาธรรมสพน์ เขตทวีวัฒนา กรุงเทพฯ 10170

โทร: 02-888-3472 โทร: ออกแบบ:08-08-170-170 แฟกซ์: 02-888-3258

https://www.add-furnace.com E-mail: sales@add-furnace.com

Honeywell

C7012A,C,E,F,G Solid State Purple Peeper® Ultraviolet Flame Detectors

PRODUCT DATA

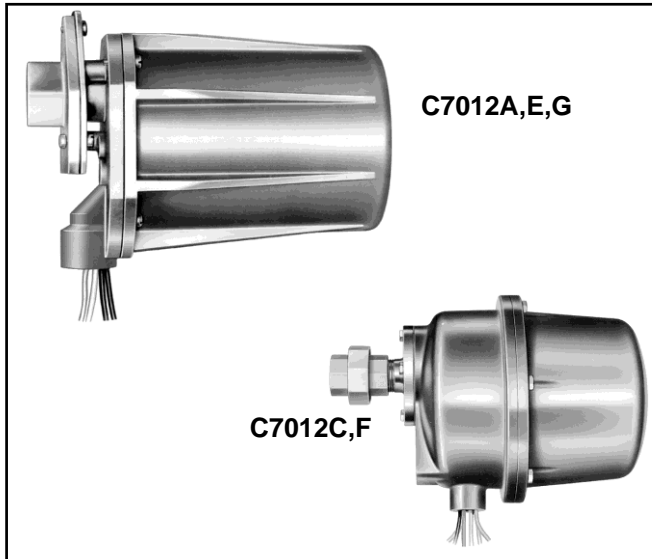

FEATURES

All models

- Solid-state electronic circuitry provides low power consumption and high reliability.
- Solid-state models directly replace previous models with vacuum electron tube circuitry.
- Detectors can be mounted horizontally, vertically or at any angle. The self-checking C7012E,F models require faceplate alignment and have integral locating reference points to assure proper shutter mechanism operation.
- Ultraviolet radiation sensing tube and quartz viewing window are field replaceable.
- Threaded conduit fitting and color-coded leadwires allow rapid electrical installation.
- Two flame detectors can be wired in parallel to reduce nuisance shutdowns in difficult flame sighting applications.
- A swivel mount is available to facilitate flame sighting.
- Models are available with a -40°F (-40°C) rating.

C7012A,C,G

- Designed for use with Honeywell Flame Safeguard Controls using Honeywell Rectification (R7247A, R7289A, R7847A1082) and Ampli-Check™ Rectification (R7247B, R7847B1072) Flame Signal Amplifiers.
- C7012G models available to meet BGC (British) and DIN (German) requirements.

C7012E,F

- Incorporate UV sensor tube checking feature; used with Honeywell Dynamic Self-Check (R7247C, R7847C) Flame Signal Amplifiers.

APPLICATION

The C7012A,C,E,F,G Flame Detectors are solid-state electronic devices for sensing the ultraviolet radiation emitted during combustion of most carbon-containing fuels such as natural gas, LP gas, and oil.

Contents

Application	1
Features	1
Specifications	2
Ordering Information	2
Installation	4
Adjustments and Checkout	12
Troubleshooting	15
Service	16

C7012E, F with R7847C Amplifier



60-2398-15



บริษัท เอดีดี เฟอร์เนส จำกัด

ADD FURNACE CO.,LTD.

44 ซอยบรมราชชนนี 70 ถนนบรมราชชนนี แขวงศาลาธรรมสพน์ เขตทวีวัฒนา กรุงเทพฯ 10170

โทร: 02-888-3472 โทร: ออกแบบ:08-08-170-170 แฟกซ์: 02-888-3258

https://www.add-furnace.com E-mail: sales@add-furnace.com

C7012A,C,E,F,G SOLID STATE PURPLE PEEPER® ULTRAVIOLET FLAME DETECTORS

- **Oscillating shutter interrupts ultraviolet radiation reaching UV sensor between 60 and 120 times per minute (10 times per minute with R7747C dynamic self-check amplifiers) to provide the UV sensortube checking function. Amplifier circuitry components are checked from the microprocessor in the BCS7700 or 7800 SERIES Control.**

C7012A,E,G

- **Housing meets NEMA 4 enclosure standards (indoor, outdoor protection: rain-tight, dust-tight, hose-directed watertight).**
- **Protective heat block built into mounting flange.**
- **High pressure 50 psi (345 kPa) quartz viewing window, focusing lens, swivel mount and antivibration mounting accessories available.**

C7012C,F

- **Housing designed to be explosion-proof and Underwriters Laboratories Inc. listed for use in hazardous locations; Class I, groups C and D; and Class II, groups E, F, and G.**
- **Viewing window rated for 100 psi (690 kPa).**

SPECIFICATIONS

IMPORTANT

The specifications in this publication do not include normal manufacturing tolerances. Therefore, this unit may not exactly match the specifications listed. This product is tested and calibrated under closely controlled conditions, and minor differences in performance can be expected if those conditions are changed.

Models:

C7012A Solid State Purple Peeper® Ultraviolet Flame Detector: For use in rectification type flame safeguard systems.

C7012C Solid State Purple Peeper® Ultraviolet Flame Detector: Same as C7012A except with explosion-proof housing for use in hazardous locations.

C7012E Self-Checking Solid State Purple Peeper® Ultraviolet Flame Detector: For use with R7247C, and R7847C Dynamic Self-Check Amplifiers.

C7012F Self-Checking Solid State Purple Peeper® Ultraviolet Flame Detector: Same as C7012E except with explosion-proof housing for use in hazardous locations.

C7012G Solid State Purple Peeper® Ultraviolet Flame Detector: Same as C7012A except designed to meet BGC (British) and DIN (German) requirements.

Electrical Ratings:

Voltage and Frequency:

C7012A: Separate models for 100, 120, 208, or 240 Vac, all 50/60 Hz

C7012E: Separate models for 100, 120, 208, or 240 Vac, all 50/60 Hz; also models for 110 or 220 volts, 50 Hz only.

C7012C and F: 120 Vac, 50/60 Hz.

C7012G: Models for 220 volts, 50 Hz only.

Power Consumption:

C7012A,C and G: 2.5 watts maximum. C7012E and

F: 7.0 watts maximum.

Ambient Operating Temperature Ratings (Outside the Case):

C7012A,C and G: 25°F to 175°F (-4°C to 79°C).

C7012E and F: -20°F to 175°F (-29°C to 79°C).

C7012A1160 and C7012E1120: -40°F to 175°F (-40°C to 79°C).

Storage Temperature Ratings:

-60°F to 175°F (-51°C to 79°C).

Housing:

C7012A,E and G: Violet, cast-aluminum cover; mounting flange (with heat block) and faceplate are separate to provide heat insulation and sealoff. Meets NEMA 4 enclosure requirements (indoor, outdoor protection; rain-tight, dust-tight, hose-directed water). Optional water jacket available for the C7012A,E,G.

C7012C and F: Explosion-proof, two-piece, violet, cast aluminum.

Pressure Rating Of Quartz Viewing Window:

C7012A,E and G: 20 psi (138 kPa). Focusing lens:

20 psi (138 kPa) rating or high pressure viewing window 50 psi (345 kPa) rating available; see Accessories section.

C7012C and F: 100 psi (690 kPa).

Mounting:

C7012A and E: Mounting flange with either 3/4 or 1 inch NPT internal threads (depending on model) for attaching to sight pipe.

ORDERING INFORMATION

When purchasing replacement and modernization products from your TRADELINE® wholesaler or distributor, refer to the TRADELINE® Catalog or price sheets for complete ordering number.

If you have additional questions, need further information, or would like to comment on our products or services, please write or phone:

1. Your local Honeywell Automation and Control Products Sales Office (check white pages of your phone directory).
2. Honeywell Customer Care
1985 Douglas Drive North
Minneapolis, Minnesota 55422-4386
3. <http://customer.honeywell.com> or <http://customer.honeywell.ca>

International Sales and Service Offices in all principal cities of the world. Manufacturing in Australia, Canada, Finland, France, Germany, Japan, Mexico, Netherlands, Spain, Taiwan, United Kingdom, U.S.A.



C7012A,C,E,F,G SOLID STATE PURPLE PEEPER® ULTRAVIOLET FLAME DETECTORS

C7012G: Mounting flange with 3/4 inch NPT internal threads for attaching to sight pipe.

C7012C and F: Pipe union with 1 inch NPT internal threads for attaching to sight pipe.

Wiring Connections:

NEC Class 1 Color-Coded Leadwires: Length: 8 feet (2.4 meters).

Number of Leadwires:

C7012A and C: 4.

C7012E and F: 6.

C7012G: 5.

C7012E1278 contains Brad Harrison™ Type 41310 Connector.

Mating connector (Brad Harrison™ Type 41306N or 41307N not provided by Honeywell).

NOTE: Models designed to meet DIN (German) and BGC (British) requirements have an additional yellow/ green leadwire that is used as a separate ground wire.

Threaded Leadwire Opening in Faceplate:

C7012A and E: 1/2-14 NPSM internal threads for attaching conduit.

C7012C and F: 1/2-14 NPT internal threads for attaching pipe.

Dimensions: See Fig. 1 or 2.

Weight:

C7012A,E and G: Approximately 4.25 pounds (1.9 kg). C7012C and F: Approximately 14.5 pounds (6.6 kg).

Serviceability:

All Models: Field-replaceable viewing window and ultraviolet sensing tube.

C7012E and F: Field-replaceable self-checking coil and shutter assembly.

NOTE: The 190971B Coil and Shutter Assembly can be used on existing C7012 Detectors with electron tubes, but the old 120625B Coil and Shutter Assembly cannot be used on solid state C7012 Flame Detectors.

Interchangeability:

Solid State C7012A,C,E,F and G Purple Peeper® Ultraviolet Flame Detectors are interchangeable with similar models of earlier C7012 Flame Detectors.

SIL 3 Capable:

The C7012E or F when used with a R7847C self-check amplifier in Relay Module EC7810A, 20A, 30A, 40L, 50A; RM7800[E, G, L, M], 30A, 38[A, B, C], 40[E, G, L, M] 50A, 90[A, B, C, D], 57[A, C], 98A is SIL 3 Capable in a properly

designed Safety Instrumented System. See form number 65- 0312 for Certificate Agreement.

Approvals:

Underwriters Laboratories Inc. Listed (120 Volt

Models Only):

C7012A and E (except C7012E1161 and E1278): File no. MP268.

C7012C and F: For use in hazardous locations; Class I, Groups C and D; Class II,

Groups E, F and G; File no. E34649.

Canadian Standards Association Certified (120 Volt Models Only): C7012A and E: Master File LR95329-1.

Factory Mutual Approved: A,C,E and F models, 14740.01.

SwissRe (formerly Industrial Risk Insurers) Acceptable.

DIN: 220 volt models of European C7012E and G are designed to meet DIN requirements.

British Gas Corporation: 110 and 240 volt models of European C7012E and G are designed to meet British Gas Corporation requirements.

Replacement Parts:

All Models:

113228 Ultraviolet Sensing Tube.

191286 Ultraviolet Sensing Tube for -40°F (-40°C) operation.

114465 Gasket, silicone rubber; for installing viewing window (three required).

C7012A,E and G:

114372 Quartz Viewing Window; rated for 20 psi (138 kPa).

32004080-001 Electronic Assembly (C7012A)

191702 Electronic Assembly with Shutter (C7012E) 120739

Gasket, fiber-neoprene; heat insulation and

seal-off for mounting flange.

C7012C and F:

122037 Quartz Viewing Window; rated for 100 psi (690 kPa).

32004080-001 Electronic Assembly (C7012C). 191702

Electronic Assembly with Shutter (C7012F).

C7012E and F:

190971B Coil and Shutter Assembly for all models except 220V/50 Hz.

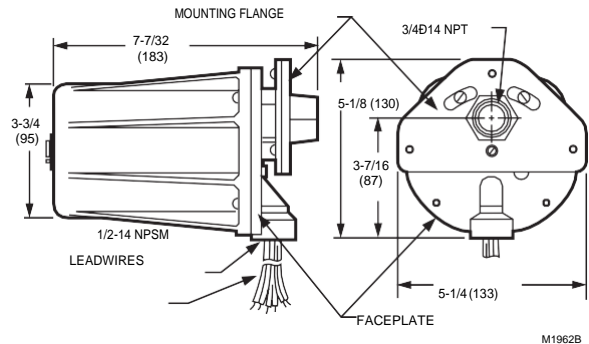

Fig. 1. Dimensions of C7012A,E, and G in in. (mm).

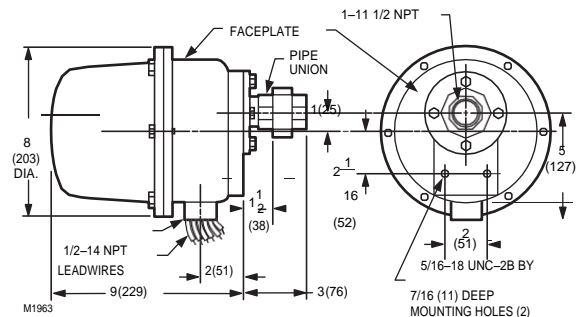

Fig. 2. Dimensions of C7012C and F in in. (mm).

Accessories:

All Models:

118369 Bushing, galvanized iron, with 3/4 inch NPT internal threads on one end and 1 inch NPT external threads on the other end. For adapting a detector with



บริษัท เอดีดี เฟอร์เนส จำกัด

ADD FURNACE CO.,LTD.

44 ซอยบรมราชชนนี 70 ถนนบรมราชชนนี แขวงศาลาธรรมสพน์ เขตทวีวัฒนา กรุงเทพฯ 10170

โทร: 02-888-3472 โทร: ออกแบบ:08-08-170-170 แฟกซ์: 02-888-3258

https://www.add-furnace.com E-mail: sales@add-furnace.com

C7012A,C,E,F,G SOLID STATE PURPLE PEEPER® ULTRAVIOLET FLAME DETECTORS

1 inch NPT internal threads (for mounting) to a 3/4 inch sight pipe, or to the pipe nipple and tee for connecting an air supply. W136A Test Meter (includes 196146 Meter Connector Plug).

117053 Meter Connector Plug (for older W136A models).

C7012A,E and G:

122748 Quartz Viewing Window, rated for 50 psi (345 kPa).

124204 Quartz Focusing Lens, rated for 20 psi (137 kPa); for increasing the detector-sensed ultraviolet radiation.

Flange, aluminum, with 1 inch NPT internal threads for attaching to sight pipe.

123539 Antivibration Mount.

190105 Water Jacket. Swivel Mount.

Seal-off Assembly, for seal-off of 3/4 in. NPT pipe.

204341A UV mirror with 3/4 in. NPT internal threads.

2. All wiring must be NEC Class 1 (line voltage).

3. Voltage and frequency of the power supply connected to this detector must agree with the values marked on the detector.

4. The detector must be sighted so it does not respond to ignition spark.

5. On multiburner installations, each detector must respond only to the flame produced by the burner it is supervising.

6. Do not connect more than two C7012 Flame Detectors in parallel.

Proper flame detector installation is the basis of a safe and reliable flame safeguard installation. Refer also to the burner manufacturer instructions. Carefully follow the instructions for the best possible flame detection application.

INSTALLATION

When Installing this Product...

1. Read these instructions carefully. Failure to follow them could damage the product or cause a hazardous condition.
2. Check the ratings given in the instructions and on the product to make sure the product is suitable for your application.
3. Installer must be a trained, experienced flame safeguard service technician.
4. After installation is complete, check outproduct operation as provided in these instructions.

CAUTION

Equipment Damage Hazard.

Sensing tube can fail to discriminate between flame conditions.

Change sensing tube after 40,000 hours of continuous use.

Appliances with burners that remain on continuously for 24 hours or longer should use the C7012E,F Flame Detector and the R7247C, or R7847C Amplifiers and associated controls.

WARNING

Electrical shock hazard.

Can cause serious injury or death.

Disconnect power supply before beginning installation to prevent electrical shock and equipment damage.

More than one disconnect can be involved.

IMPORTANT

1. Do not connect these detectors to non-Honeywell manufactured controls (primaries, programmers, multiburner systems, and burner management systems). Unsafe conditions could result.

Basic Requirements

The combustion flames of most carbon-based fuels emit sufficient ultraviolet radiation to enable the C7012 Solid State Purple Peeper® Ultraviolet Flame Detector to prove the presence of a flame in a combustion chamber. The detector is mounted outside the combustion chamber. Its mounting flange or union is threaded to one end of a sight pipe inserted through the wall of the combustion chamber. The ultraviolet sensing tube in the flame detector sights the flame through the pipe.

When a flame is present, the UV tube in the C7012 senses the ultraviolet radiation emitted. The C7012 produces a signal that is sent to the amplifier in the flame safeguard control. The amplified signal pulls the flame relay into the control to allow proper operation of the system.

Because it is necessary for the UV sensing tube to actually see the flame, it is best to locate the detector as close to the flame as physical arrangement, temperature, and other restrictions permit. These restrictions are described in detail in the following paragraphs.

Determine Location

Before beginning the actual installation, determine the best location for mounting the detector. Carefully consider the factors discussed in this section before deciding on the location.

Temperature

Install the C7012 where the ambient temperature (outside the case) stays within the ambient operating temperature ratings.

To keep the C7012 below its maximum rating, it may be necessary to add additional insulation between the wall of the combustion chamber and the detector. A shield or screen can be added to reflect radiated heat away from the detector. If the detector continues to get too hot, cooling is necessary. Refer to the Sight Pipe Ventilation section. A 190105 Water Jacket is also available for cooling the C7012A,E,G Flame Detectors. See Accessories.

Vibration

If the C7012 is subject to excessive vibration, use a special 123539 Antivibration Mount for the C7012A,E or G. If you use this mount, install it before you position and sight the detector.



Clearance

Make sure there is enough room to easily mount the sight pipe, detector and all required fittings, and to remove the detector for troubleshooting and servicing.

Radiation Sources (Other Than Flame)

Examples of radiation sources (other than flame) that could actuate the detection system:

1. Ultraviolet sources:
 - a. Hot refractory above 2300°F (1260°C).
 - b. Spark:
 - (1) Ignition transformers.
 - (2) Welding arcs.
 - (3) Lightning.
 - c. Welding flames.
 - d. Bright incandescent or fluorescent artificial light.
 - e. Solar radiation.
 - f. Gas lasers.
 - g. Sun lamps.
 - h. Germicidal lamps.
 - i. Bright flashlight held close to sensing tube.
2. Gamma ray and X-ray sources:
 - a. Diffraction analyzers.
 - b. Electron microscopes.
 - c. Radiographic X-ray machines.
 - d. High voltage vacuum switches.
 - e. High voltage condensers.
 - f. High voltage coronas.
 - g. Radioisotopes.

Except under unusual circumstances, none of these sources except hot refractory and ignition spark would be present in or near the combustion chamber.

The detector may respond to hot refractory above 2300°F (1260°C) if the refractory surface represents a significant percentage of the detector field of view. If the temperature of the hot refractory causes the flame relay (in the flame safeguard control) to pull in, re-aim the sight pipe so the detector views a cooler area of the refractory.

Ignition spark is an intense source of ultraviolet radiation. When installing the detector, make sure it does not respond to ignition spark.

Single Burner Requirements

The detector must have an unobstructed view of a steady part of the flame it is supervising. This requires a proper sighting angle and minimized ultraviolet radiation attenuation effects. Supervising only one burner simplifies sighting requirements.

Sighting Angle (Fig. 3)

The first 30 percent of a flame closest to the burner nozzle (the flame root) emits the most ultraviolet energy. Also, if the detector sights the flame at an angle instead of perpendicularly, it views more flame depth. Therefore, the best sighting angle is nearly parallel to the axis of the flame, permitting the detector to view a large portion of the first 30 percent of the flame closest to the burner nozzle, as illustrated in Fig. 3.

Low angle sighting permits the detector to view a greater depth of flame, thus reducing the effects of instabilities in the flame pattern. Also, the environment near the burner nozzle is usually cleaner than at any other part of the combustion chamber. This provides a clearer line of sight and can keep the viewing window cleaner, thus reducing the maintenance required.

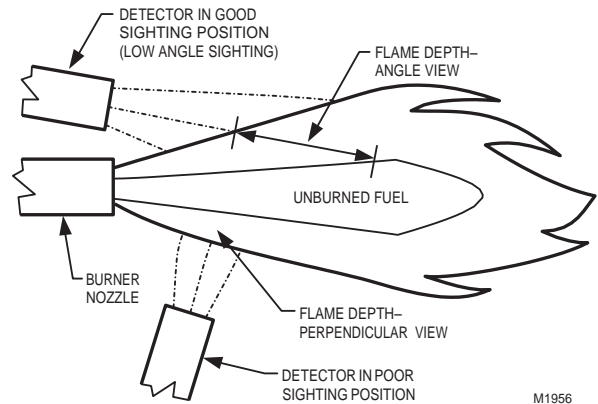

Fig. 3. Detector sighting angle.

NOTE: When possible, it is desirable to tilt the detector and sight pipe downward to prevent the buildup of soot in the pipe or on the viewing window.

In most installations, the detector needs to respond to the pilot flame alone, then the pilot and main burner flame together, and finally the main burner flame alone. The detector must meet all sighting requirements that apply:

Pilot flame alone—the smallest pilot flame that can be detected must be capable of reliably igniting the main burner.

Pilot and main burner flame together—the detector must sight the junction of both flames.

Main burner flame alone—the detector must sight the most stable part of the flame for all firing rates.

Parallel Flame Detectors

Shifting flame patterns, commonly encountered on burners with high turndown ratios, can require two parallel detectors to prove the flame at the highest and lowest firing rates and for modulation in between. In this case, one detector supervises the pilot (interrupted) and both detectors supervise the main burner flame. During the main burner run period, either detector is capable of maintaining system operation. A maximum of two C7012 Detectors can be connected in parallel.

In addition to assuring more reliable flame detection, parallel detectors facilitate maintenance during burner operation. Each detector can be removed, in turn, without shutting down the supervised burner. However, a flame simulating failure occurring in the flame signal amplifier or in either detector causes a shutdown.



C7012A,C,E,F,G SOLID STATE PURPLE PEEPER® ULTRAVIOLET FLAME DETECTORS

Screening Effects

Smoke, oil mist, dirt and dust are masking agents that attenuate the ultraviolet radiation that the flame emits. If they absorb too much radiation, the amount of ultraviolet radiation reaching the detector is reduced. The flame signal then can become too low to hold in the flame relay, resulting in burner shutdown.

Diluting the contaminants can eliminate the problem. A strong flow of air through the sight pipe clears a viewing path through the attenuating material. Refer to the Sight Pipe Ventilation section.

It is also desirable to sight the detector in an area containing fewer masking agents such as near the burner nozzle or near the entrance of the combustion air. Increasing the viewing area of the detector by shortening the sight pipe or by increasing the diameter of the sight pipe also reduces the attenuating effects of masking agents.

Multiburner Requirements

(Flame Discrimination)

In addition to meeting the requirements for a single burner, a multiburner installation requires discrimination between flames. Flame discrimination can be defined as locating all flame detectors so that each detector responds only to the flame of

the burner it is supervising.

In multiple burner systems, not every detector can be positioned so its line-of-sight does not intercept flames from other burners. For example, this situation occurs in front-fired boiler-furnaces having more than one row of burners, or in multilevel opposed-fired furnaces where the burners face each other.

When planning such an installation, locate each flame detector so that it has the best possible view of the first 30 percent closest to the burner nozzle (the flame root) it is supervising, and the worst possible view of all other flames.

Fig. 4 illustrates a critical detector application problem that requires flame discrimination. Flame discrimination is accomplished for Detector A by repositioning it until the flame relay (in the flame safeguard control) does not respond to Flame B. Note that Detector A is aimed at the first 30 percent of Flame A where the ultraviolet radiation is most intense.

It sights the tip of Flame B, but it is not aimed at the first 30 percent of Flame B where UV is intense. Detector A is repositioned to assure maximum response to Flame A while rejecting Flame B. Similarly, Detector B is positioned to assure maximum response to Flame B while rejecting Flame A.

If you reposition a detector and still cannot achieve flame discrimination, try reducing the viewing area by increasing the length or decreasing the diameter of the sight pipe, or adding an orifice plate.

Install the Sight Pipe (Fig. 5)

After you have determined the location and sighting angle, select the sight pipe. A black iron pipe with a diameter of at least 1-1/2 in. (38 mm) is recommended. Do not use stainless steel or galvanized pipe because they reflect ultraviolet radiation internally and complicate aiming the pipe.

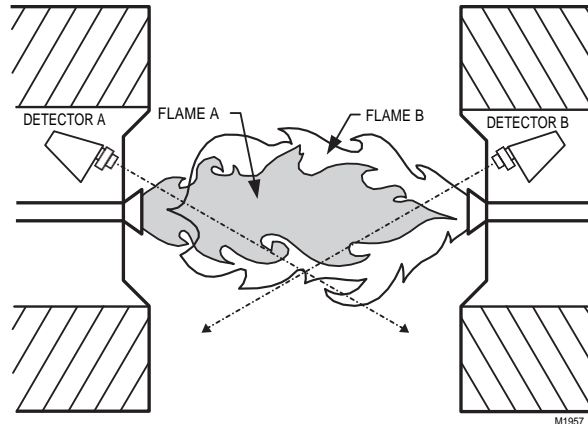

Fig. 4. Example of flame discrimination problem (opposed-fired burners).

Sight pipes with diameters 2 to 3 in. (51 to 76 mm) produce better results for horizontal rotary burners, which require wide viewing angles. A wide viewing angle can also be obtained by using a short sight pipe.

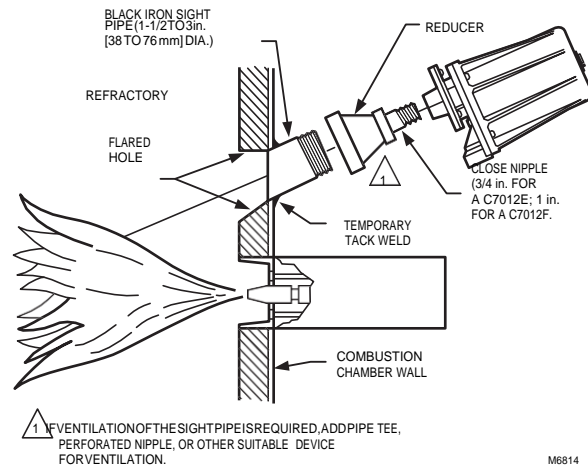

Fig. 5. Typical mounting of C7012.

Prepare Hole in Combustion Chamber Wall

Cut or drill a hole of the proper diameter for the sight pipe in the wall of the combustion chamber at the selected location. Flare the hole to leave room for small adjustments of the sighting angle. The taper of the hole should be about 1 in. for every 3 in. (25 mm for every 76 mm) of wall thickness.

Mount Sight Pipe

Thread one end of the pipe to fit the mounting flange, union, or required coupling. Cut the pipe to the desired length (as short as practical) and at an angle so it fits flush with the wall of the combustion chamber. Tack weld the pipe to the wall in a trial position. Do not weld the sight pipe permanently in place until after completing the Adjustments and Checkout procedures.



C7012A,C,E,F,G SOLID STATE PURPLE PEEPER® ULTRAVIOLET FLAME DETECTORS

NOTE: If you use 118367A Swivel Mount and you are positive about the location and sighting angle, you can permanently weld the pipe.

(see Fig. 6). The C7012F must be mounted with the conduit opening located approximately 45 degrees below the horizontal (see Fig. 6).

Install Fittings

In some cases, the sight pipe will not directly fit the C7012 mounting flange or union. Also, it may be desirable or necessary to ventilate the sight pipe. You may also want to use a swivel mount or an antivibration mount. Each of these cases can require additional fittings.

Reducer

For sight pipes of larger diameter than the mounting flange connector or union, install a reducer as illustrated in Fig. 5. The reducer requires a close nipple with these external threads:

C7012A or E: 3/4 or 1 in. NPT (depending on model). C7012C or

F: 1 in. NPT.

C7012G: 3/4 in. NPT.

Sight Pipe Ventilation (C7012A,E, or

G)

It may be necessary to ventilate the sight pipe to cool the detector or to clear a viewing path through UV radiation attenuating material.

For a negative pressure combustion chamber, drilling a few holes in the section of the sight pipe outside of the combustion chamber allows air at atmospheric pressure to flow through the sight pipe and into the chamber. A perforated pipe nipple between the sight pipe and the detector can also be used.

For a positive pressure combustion chamber, connect a supply of pressurized air from the burner blower to flow through the sight pipe and into the chamber. The air pressure must be greater than the chamber pressure.

Antivibration Mount (C7012A,E, or G)

The detector can withstand normal burner vibration. If the vibration is excessive, part no. 123539 Antivibration Mount is available for a C7012A,E or G. (For mounting details, see form 60-0361.) If you use this mount, install it before positioning and sighting the detector.

Mount the Detector (Fig. 5-8)

Mount the detector onto the sight pipe, reducer, or other fitting (see Fig. 5-8).

The C7012A,C,G Flame Detectors do not have the oscillating shutter mechanism for checking the UV sensor so they can be mounted in any position suitable for the temperature environment.

The C7012E,F Self-Checking Flame Detectors incorporate an oscillating shutter mechanism and, therefore, require special consideration for mounting positions other than vertically sighting downward or upward. The C7012E has notch and arrow indicators (see Fig. 6) on the faceplate to facilitate mounting. The notch and arrow must be vertically aligned with the notch in the up position and the arrow pointing downward

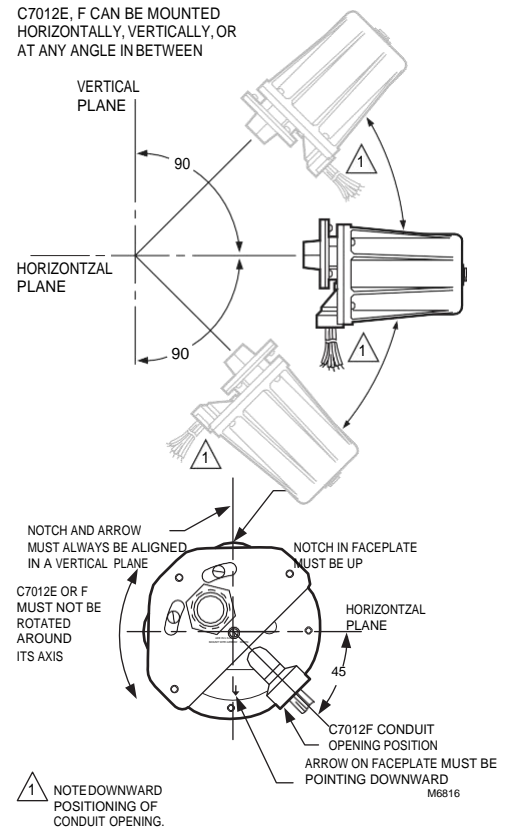

Fig. 6. C7012E,F mounting positions.

IMPORTANT

The notch and arrow on the faceplate of the C7012E must be aligned in a vertical plane with the notch up and the arrow pointing downward.

The C7012F housing must be mounted with the conduit opening approximately 45° below horizontal (see Fig. 6).

To mount a C7012A,E or G (Fig. 7):

1. The mounting flange has two pieces. Loosen (but do not remove) the three screws holding the flange together.
2. Slightly rotate the detector so the slots in the back section of the mounting flange clear the screws in the front section; then separate the two sections.
3. Screw the front section of the mounting flange onto the sight pipe, reducer, or other fitting.
4. Fit the slots in the back section of the mounting flange (with the detector) over the three screws in the front section, and rotate the detector so the screws hold the flange together.
5. Tighten the screws securely.



C7012A,C,E,F,G SOLID STATE PURPLE PEEPER® ULTRAVIOLET FLAME DETECTORS

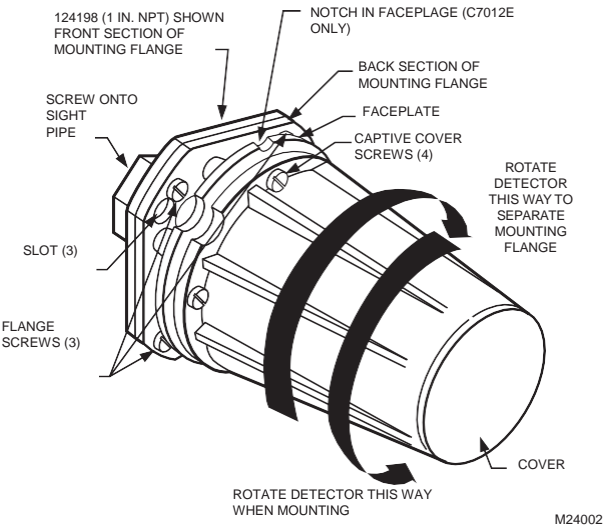

Fig. 7. Mounting C7012A, E, or G Detector.

To mount a C7012C or F with explosion-proof housing (Fig. 8):

1. Unscrew the collar on the pipe union and remove the coupling section. The collar and coupling are in two pieces; do not separate them.
2. Screw the coupling onto the sight pipe, reducer, or other fitting.
3. Mount the remainder of the pipe union (with the detector) onto the coupling and securely tighten the collar.

Wiring (Fig. 9-16)

CAUTION

Equipment Damage Hazard.

Improper wiring can permanently damage amplifier.

When using a C7012E or F with an R7247C, R7847C Dynamic Self-Check Amplifier, be careful not to short the white shutter leadwires together (by wiring incorrectly, leaving an incorrect jumper wire, or stripping the insulation too much so the bare leadwires can touch).

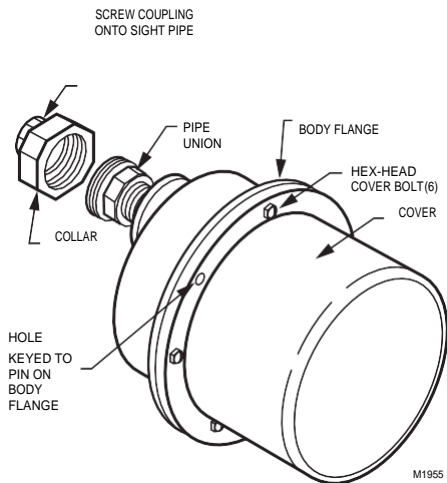

Fig. 8. Mounting C7012C or F Detector.

IMPORTANT

Certain C7012E and all G models are designed to meet DIN and BGC requirements. They have an additional yellow/green grounding leadwire; connect this wire to a separate ground terminal on the wiring sub-base.

1. All wiring must comply with applicable local electrical codes, ordinances and regulations.

NOTE: The detector has color-coded and labeled, plastic insulated, no. 18 leadwires, 8 feet (2/4 m) long, rated for 221°F (105°C).

2. Keep the flame signal leadwires as short as possible from the flame detector to the terminal strip or wiring subbase.

NOTE: Capacitance increases with leadwire length, reducing the signal strength. The maximum permissible leadwire length depends on the type of leadwire, conduit type and diameter. The ultimate limiting factor in flame signal leadwire length is the signal current or

voltage at the flame safeguard device. Refer to Table 1.

3. Detector leadwires can be spliced for longer leadwire runs, observing the following considerations (see Fig. 9):
 - a. Make required splices in a junction box.
 - b. Use moisture-resistant no. 14 wire suitable for at least 167°F (75°C).
 - c. For high temperature installations, use Honeywell specification No. 32004766-003 or equivalent for the F leadwire. This wire is rated up to 400°F (250°C) for continuous duty. It is tested for operation up to 20,000 volts and for breakdown up to 32,000 volts. For the other leadwires, use moisture-resistant no. 14 wire selected for a temperature rating above the maximum operating temperature.
 - d. F and G wires (blue and yellow) must be run in their own conduit independent of other power carrying leadwires. More than one set of scanner F and G wires can be run in the same conduit.
 - e. A shielded twisted pair wire may be substituted for conduit for routing the F leadwire (blue). Be advised of the capacitance per foot of shielded wire effectively reduces the flame signal at the flame safeguard device. Be sure to ground the shield to the G terminal at the flame safeguard wiring subbase.
 - f. The detector power and shutter wires need to be run in their own conduit as well, avoiding other electrical noise carrying wiring.
 - g. The scanner wires should remain separated a minimum of 2 inches from other line voltage wires in the main control panel to the flame safeguard device.
4. The following installation considerations can influence detector operation and maximum leadwire length and should be avoided:
 - a. Moisture.
 - b. Ignition interference.
 - c. high resistance connections or poor grounds.
 - d. Leadwire capacitance.
 - e. Voltage fluctuations.
 - f. Induced line transients.
 - g. Floating grounds—ground at some voltage above earth ground.
 - h. No G wire—burner used as ground.
 - i. Detector output less than maximum attainable for the installation (inadequate sighting).
5. Refer to Fig. 10 through 17 for wiring connections.



C7012A,C,E,F,G SOLID STATE PURPLE PEEPER® ULTRAVIOLET FLAME DETECTORS

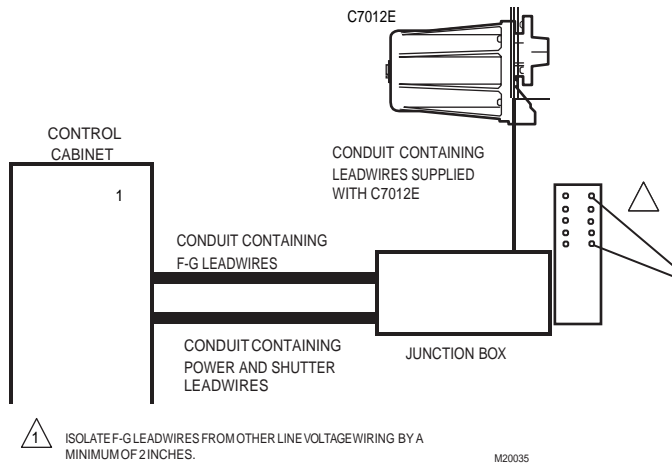

Fig. 9. Splicing leadwires in a junction box.

IMPORTANT

Do not run the flame detector wiring in the same conduit with high voltage ignition transformer wires.

Connecting Detectors in Parallel

For a flame that is difficult to sight, using two parallel C7012 Flame Detectors reduces nuisance shutdowns. If only one of the parallel detectors loses the flame signal, the other will indicate the presence of the flame and keep the burner running. When two parallel C7012E or F Detectors (with self-checking shutters) are used, a flame-simulating failure in either detector system causes the burner to shut down. Two C7012E or F Detectors can be connected in parallel to the same terminals on 120 volt flame safeguard controls. To avoid exceeding the rating of the solid-state shutter switch in the R7247C, R7747C, R7847C Flame Signal Amplifier, do not connect more than two C7012E or F Detectors in parallel.

IMPORTANT

Voltage and frequency rating of the C7012 must match the power supply of the flame safeguard control.

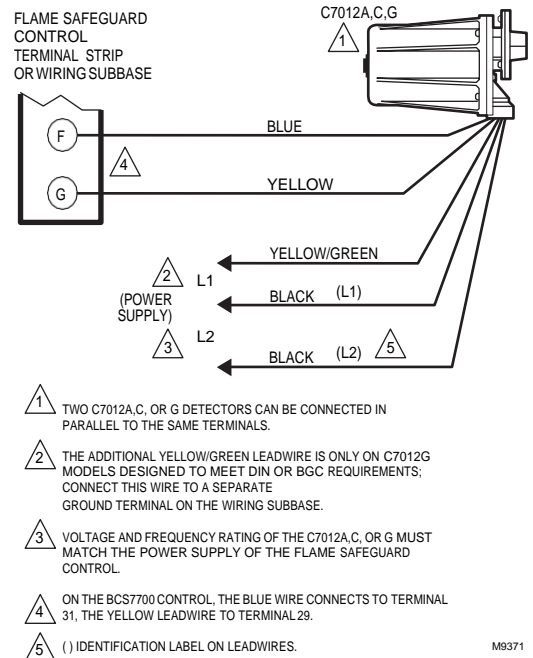

- 1 TWO C7012A,C, OR G DETECTORS CAN BE CONNECTED IN PARALLEL TO THE SAME TERMINALS.
- 2 THE ADDITIONAL YELLOW/GREEN LEADWIRE IS ONLY ON C7012G MODELS DESIGNED TO MEET DIN OR BGC REQUIREMENTS; CONNECT THIS WIRE TO A SEPARATE GROUND TERMINAL ON THE WIRING SUBBASE.
- 3 VOLTAGE AND FREQUENCY RATING OF THE C7012A,C, OR G MUST MATCH THE POWER SUPPLY OF THE FLAME SAFEGUARD CONTROL.
- 4 ON THE BCS7700 CONTROL, THE BLUE WIRE CONNECTS TO TERMINAL 31, THE YELLOW LEADWIRE TO TERMINAL 29.
- 5 () IDENTIFICATION LABEL ON LEADWIRES.

Fig. 10. Wiring diagram for C7012A,C, or G Detectors with rectification type, flame safeguard primary and programming controls.

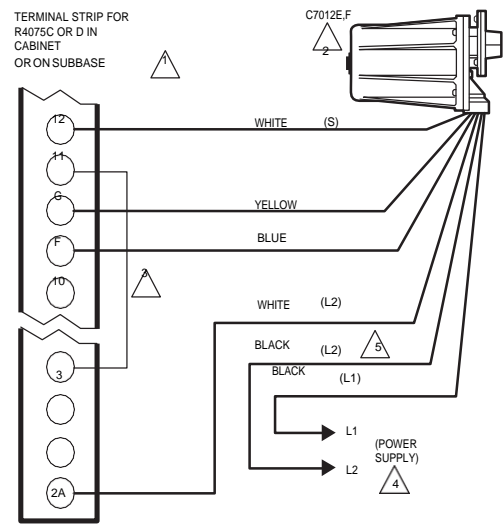

- 1 AN R7247C DYNAMIC SELF-CHECK AMPLIFIER MUST BE USED WITH AN R4075C OR D.
- 2 TWO C7012E OR F DETECTORS CAN BE CONNECTED IN PARALLEL TO THE SAME TERMINALS ONLY ON 120 VOLT CONTROLS.
- 3 REMOVE THE JUMPERS BETWEEN TERMINALS 12 AND F AND BETWEEN TERMINALS 11 AND 10 (IF THERE ARE JUMPERS), AND INSTALL A JUMPER BETWEEN TERMINALS 11 AND 3.
- 4 VOLTAGE AND FREQUENCY RATING OF THE C7012E OR F MUST MATCH THE POWER SUPPLY OF THE FLAME SAFEGUARD CONTROL.
- 5 () IDENTIFICATION LABEL ON LEADWIRES.

Fig. 11. Wiring diagram for C7012E or F Detectors with R4075C or D (currently obsolete) Flame Safeguard Controls.



บริษัท เอดีดี เฟอร์เนส จำกัด

ADD FURNACE CO.,LTD.

44 ซอยบรมราชชนนี 70 ถนนบรมราชชนนี แขวงศาลาธรรมสพน์ เขตทวีวัฒนา กรุงเทพฯ 10170

โทร: 02-888-3472 โทร: ออกแบบ:08-08-170-170 แฟกซ์: 02-888-3258

https://www.add-furnace.com E-mail: sales@add-furnace.com

C7012A,C,E,F,G SOLID STATE PURPLE PEEPER® ULTRAVIOLET FLAME DETECTORS

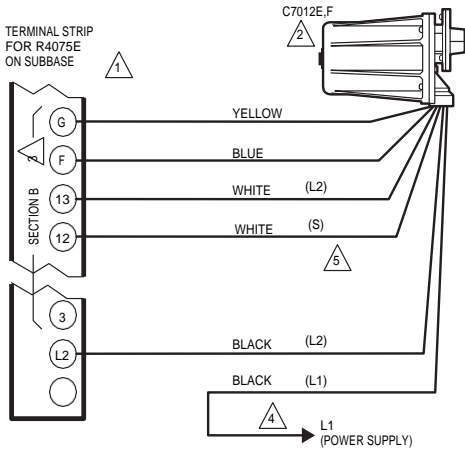

- 1 AN R7247C DYNAMIC SELF-CHECK AMPLIFIER MUST BE USED WITH AN R4075E.
- 2 TWO C7012E OR F DETECTORS CAN BE CONNECTED IN PARALLEL TO THE SAME TERMINALS ONLY ON 120 VOLT CONTROLS.
- 3 WIRING IS SHOWN FOR SECTION B. CONNECT ANOTHER DETECTOR TO THE IDENTICAL TERMINALS IN SECTION A. TERMINAL L2 IS USED FOR BOTH SECTIONS.
- 4 VOLTAGE AND FREQUENCY RATING OF THE C7012E OR F MUST MATCH THE POWER SUPPLY OF THE FLAME SAFEGUARD CONTROL.
- 5 () IDENTIFICATION LABEL ON LEADWIRES.

M8373

Fig. 12. Wiring diagram for C7012E or F Detectors with R4075E (currently obsolete) Flame Safeguard Control.

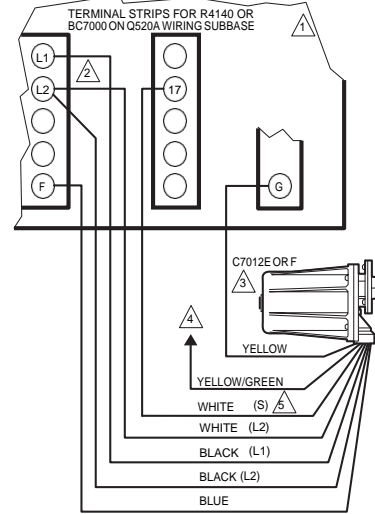

- 1 AN R7247C DYNAMIC SELF-CHECK AMPLIFIER MUST BE USED WITH AN R4140, BC7000.
- 2 VOLTAGE AND FREQUENCY RATING OF THE C7012E OR F MUST MATCH THE POWER SUPPLY OF THE FLAME SAFEGUARD CONTROL.
- 3 TWO C7012E OR F DETECTORS CAN BE CONNECTED IN PARALLEL WITH THE SAME TERMINALS ONLY ON 120 VOLT CONTROLS.
- 4 THE ADDITIONAL YELLOW/GREEN LEADWIRE IS ONLY ON C7012E MODELS DESIGNED TO MEET DIN OR BGC REQUIREMENTS; CONNECT THIS WIRE TO A SEPARATE GROUND TERMINAL ON THE WIRING SUBBASE.
- 5 () IDENTIFICATION LABEL ON LEADWIRES.

M8375A

Fig. 14. Wiring diagram for C7012E or F Detectors with R4140, and BC7000 (currently obsolete), and R7140 Flame Safeguard controls.

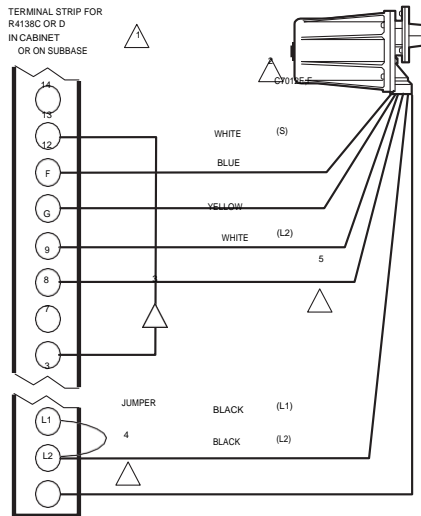

- 1 AN R7247C DYNAMIC SELF-CHECK AMPLIFIER MUST BE USED WITH AN R4138C OR D.
- 2 TWO C7012E OR F DETECTORS CAN BE CONNECTED IN PARALLEL WITH THE SAME TERMINALS ONLY ON 120 VOLT CONTROLS.
- 3 REMOVE THE JUMPERS BETWEEN TERMINALS 14 AND 13 AND BETWEEN TERMINALS 12 AND F (IF THERE ARE JUMPERS), AND INSTALL A JUMPER BETWEEN TERMINALS 13 AND 7.
- 4 VOLTAGE AND FREQUENCY RATING OF THE C7012E OR F MUST MATCH THE POWER SUPPLY OF THE FLAME SAFEGUARD CONTROL.
- 5 () IDENTIFICATION LABEL ON LEADWIRES.

M8374

Fig. 13. Wiring diagram for C7012E or F Detectors with R4138C,D (currently obsolete) Flame Safeguard controls.

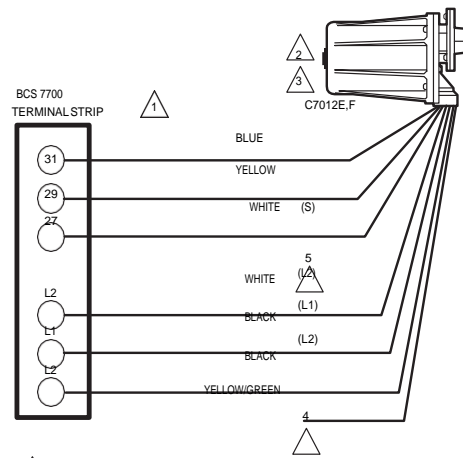

- 1 AN R7247C DYNAMIC SELF-CHECK AMPLIFIER MUST BE USED WITH THE C7012E F/BCS 7700 COMBINATION. SHUTTER CYCLE RATE IS 12 TIMES PER MINUTE. USE SERIES 7 OR GREATER FOR THESE APPLICATIONS.
- 2 VOLTAGE AND FREQUENCY RATING OF THE C7012E,F MUST MATCH THE POWER SUPPLY OF THE FLAME SAFEGUARD CONTROL.
- 3 TWO C7012E,F DETECTORS CAN BE CONNECTED IN PARALLEL TO THE SAME TERMINALS ONLY ON 120 VOLT CONTROLS.
- 4 THE ADDITIONAL YELLOW/GREEN LEADWIRE IS ONLY ON C7012E MODELS THAT MEET BGC OR DIN REQUIREMENTS; CONNECT YELLOW/GREEN WIRE TO A SEPARATE GROUND TERMINAL ON THE WIRING SUBBASE.
- 5 () IDENTIFICATION LABEL ON LEADWIRES.

M8376

Fig. 15. Wiring diagram for C7012E,F Detectors with BCS 7700 (currently obsolete) Flame Safeguard controls.



บริษัท เอดีดี เฟอร์เนส จำกัด

ADD FURNACE CO.,LTD.

44 ซอยบรมราชชนนี 70 ถนนบรมราชชนนี แขวงศาลาธรรมสพน์ เขตทวีวัฒนา กรุงเทพฯ 10170

โทร: 02-888-3472 โทร: ออกแบบ:08-08-170-170 แฟกซ์: 02-888-3258

https://www.add-furnace.com E-mail: sales@add-furnace.com

C7012A,C,E,F,G SOLID STATE PURPLE PEEPER® ULTRAVIOLET FLAME DETECTORS

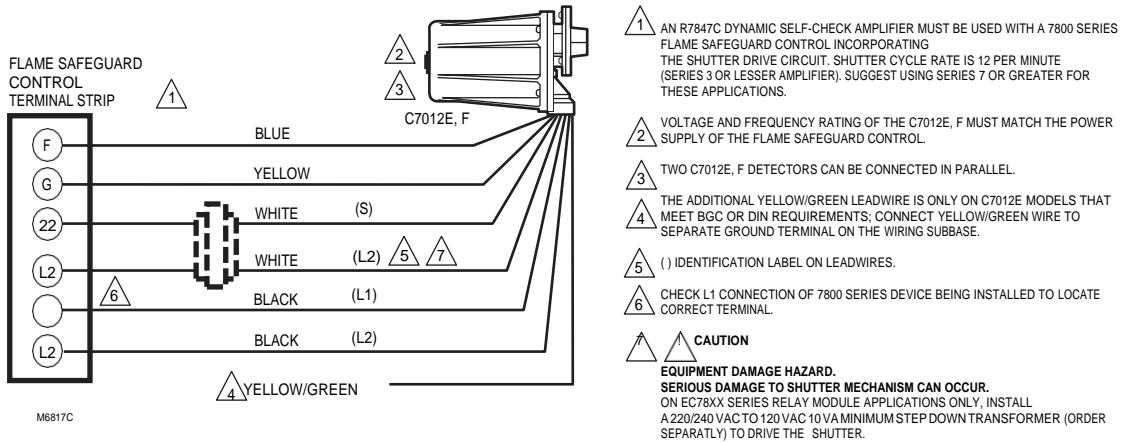

Fig. 16. Wiring diagram for C7012E,F Detectors with 7800 SERIES Flame Safeguard Controls with shutter drive circuitry.

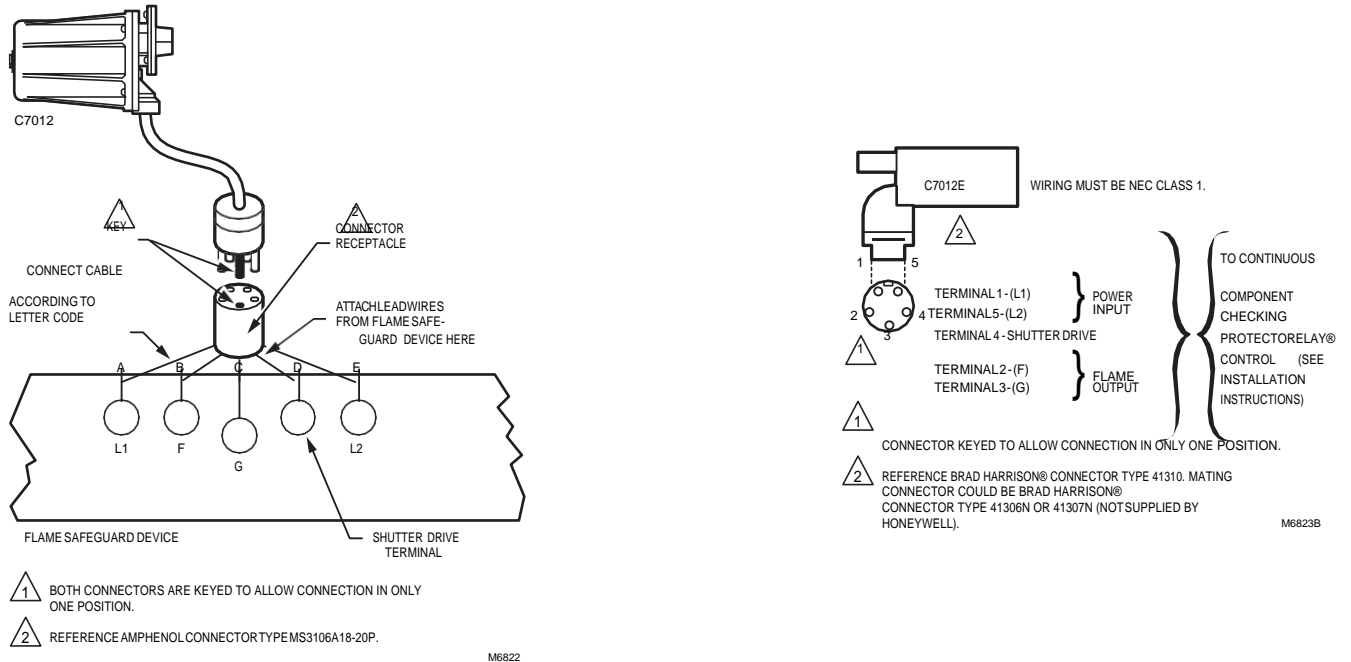

Fig. 17. Wiring connection for C7012E1161 or C7012E1278.



C7012A,C,E,F,G SOLID STATE PURPLE PEEPER® ULTRAVIOLET FLAME DETECTORS

ADJUSTMENTS AND CHECKOUT

UV Sensor Tube Test

For initial burner lightoff, consult the burner manufacturer instructions or the instructions for the flame safeguard control.

If the system does not start during the initial burner lightoff, check the UV sensor tube in the flame detector. If a reddish glow appears when there is no flame present, replace the UV sensing tube. When performing this test, make sure there are no extraneous sources of ultraviolet radiation in the test area (see Radiation Sources section).

Adjust Detector Sighting

With the flame detector installed and the burner running, adjust the sighting position of the detector for optimum flame signal.

Most existing Honeywell flame safeguard controls incorporate a flame current jack on the control flame amplifier or on the control itself. Measure the flame signal with a volt-ohmmeter such as the Honeywell W136A Volt-ohmmeter (see Fig. 17). To measure the flame current (signal), use 196146 Cable Connector, included with W136A, in conjunction with the meter. With the W136A (or equivalent) positioned to the zero to 25 microampere scale, connect the meter probes to the two ends of the cable connector plug (red to red, black to black). Insert the plug end of the connector plug directly into the flame jack of the control or control amplifier (see Fig. 17). The W136A Meter then directly reads the flame signal in microamperes. Refer to Table 1 for minimum acceptable flame currents.

The R7747C and R7847C Amplifiers used with the BCS 7700 and 7800 Series Flame Safeguard controls, respectively, have a dc voltage flame signal output. For the R7747C Amplifiers, a volt-ohmmeter with a 20,000 ohm/volt minimum input impedance and a zero to five or ten Vdc scale is recommended. It is suggested that a volt-ohm meter with a minimum sensitivity of one megohm/volt and a zero to five or ten Vdc scale be used for R7847C Amplifier flame signal measurements. Measure the flame signal as illustrated in Fig. 18 and 19. Be careful to make the proper connections of positive (red) meter lead to positive (+) control jack and negative (black) meter lead to negative (-) or (-Com) jack with 7800 Series controls. If the BCS 7700 and 7800 Series controls have the Keyboard Display Module, a zero to five Vdc voltage displays on the module.

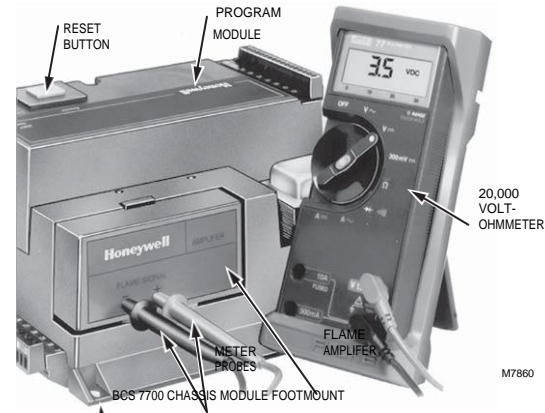

Fig. 19. Measuring voltage flame signal with BCS 7700 (currently obsolete) controls.

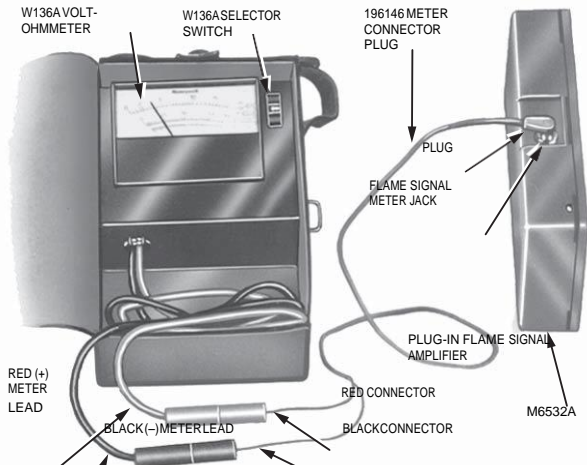

Fig. 18. Measuring microamp flame signal.

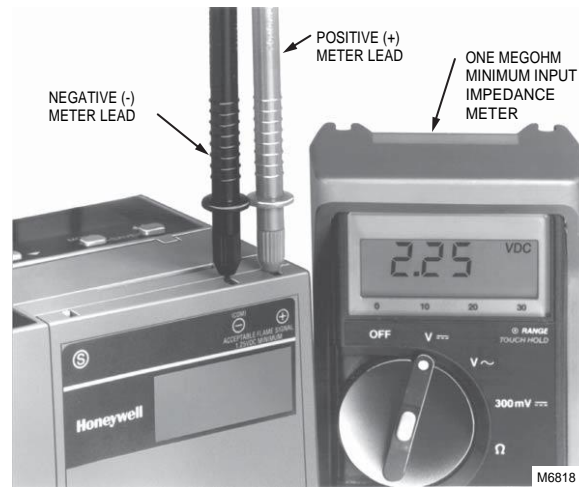

Fig. 20. Measuring voltage flame signal with 7800 Series controls.



บริษัท เอดีดี เฟอร์เนส จำกัด

ADD FURNACE CO.,LTD.

44 ซอยบรมราชชนนี 70 ถนนบรมราชชนนี แขวงศาลาธรรมสพน์ เขตทวีวัฒนา กรุงเทพฯ 10170

โทร: 02-888-3472 โทร: ออกแบบ:08-08-170-170 แฟกซ์: 02-888-3258

<https://www.add-furnace.com> E-mail: sales@add-furnace.com

C7012A,C,E,F,G SOLID STATE PURPLE PEEPER® ULTRAVIOLET FLAME DETECTORS

NOTE:

1. If using an R7247B Ampli-Check™ or C Dynamic Self-Check Amplifier, set the selector switch on the W136A Meter to the SPL (damped) position. Allow a few seconds for the current to stabilize. The red flame indicating lamp on the amplifier should blink about one to four times a second (from bright to dim). If the lamp is on or off continuously while reading the flame signal, replace the amplifier.
2. For a C7012E or F, the shutter operation causes fluctuations in the current or voltage reading. Read the average stable current, disregarding the peaks.
3. The flame signal must be steady (or stable as described in NOTE 2).

Move around the detector and sight pipe to sight the flame from various positions and angles. Try to get a maximum steady (or stable) reading on the meter that is above the minimum acceptable current listed in Table 1.

Measure the flame signal for the pilot alone, the main burner flame alone, and both together (unless monitoring only the pilot flame when using an intermittent pilot, or only the main burner flame when using direct spark ignition). With the detector in its final position, all required flame signals must be steady (or stable) and as specified in Table 1. If you cannot obtain the proper signal, refer to the Troubleshooting section.

Pilot Turndown Test

If the detector is used to prove a pilot flame before the main fuel valve(s) can be opened, perform a Pilot Turndown Test before welding the sight pipe into position. Follow the procedures in the flame safeguard control instructions and in the burner manufacturer instructions.

Ultraviolet Response Tests Ignition Spark Response Test

Test to be sure that ignition spark is not actuating the flame relay (usually 2K) in the flame safeguard control.

1. Close the pilot and main burner manual shutoff valves.
2. Start the burner and run through the Ignition period. Ignition spark should occur, but the flame relay must not pull in. The flame signal should not be greater than 0.25 microampere for most Honeywell controls and not greater than 1.0 Vdc for BCS 7700 controls nor larger than 0.25 Vdc for 7800 Series controls.
3. If the flame relay does pull in, reposition the detector farther from the spark, or relocate or resight the detector to eliminate or reduce the detector response to reflected UV radiation. It may be necessary to construct a barrier to block the ignition spark from the detector view. Continue adjustments until the flame signal due to ignition spark is less than the flame signal values indicated in step 2.

Response to Other Ultraviolet Radiation Sources

Some sources of artificial light produce small amounts of ultraviolet radiation. Under certain conditions, an ultraviolet detector responds to them as if it is sensing a flame. Do not use an artificial light source to check the response of an Ultraviolet Flame Detector. To check for proper detector operation, conduct flame failure response tests under all operating conditions.

Weld the Sight Pipe

When the flame signal is acceptable after all adjustments are made, remove the detector and weld the sight pipe in its final position. (If you are using a swivel mount, the pipe may be already welded.) Then reinstall the detector.

Final Checkout

Before putting the burner into service, check out the installation using the Checkout procedures in the Instructions for the appropriate flame safeguard control. After completing the Checkout, run the burner through at least one complete cycle to verify correct operation.

IMPORTANT

Do not put the system into operation until all Checkout tests in the Instructions for the appropriate flame safeguard control and any others specified in the burner installation instructions are completed satisfactorily.



C7012A,C,E,F,G SOLID STATE PURPLE PEEPER® ULTRAVIOLET FLAME DETECTORS

Table 1. Flame Signal.

Flame Detector	Plug-in Flame Signal Amplifier	Flame Safeguard Control(s)	Minimum ^a Acceptable Steady Current (uA)	Maximum Expected Current (uA)	Minimum ^a Acceptable Steady Voltage (Vdc)	Maximum Expected Voltage (Vdc)
C7012A,C	R7247A	R4075C,D,E ^g ; R4138C,D ^g ; R4140G,L,M; BC7000L	2.0	6.0	—	—
	R7247B ^b Ampli- Check™	R4075C,D,E ^g ; R4138C,D ^g ; R4140G,L,M; BC7000L	2.0	4.0	—	—
	R7289A	R4795A	2.0	6.0	—	—
	None	R485B ^g ; R7023B ^g ; R7795B,D,F,H; RA890F	2.0	5.0	—	—
	R7847A	R7140G,L,M RM7800E,G,L,M; RM/EC7823A; RM7838A,B; RM7840E,G,L,M; RM/EC7890A,B; RM/ EC7895A,B,C,D	—	—	1.25	5.0
	R7847B ^b Ampli- Check™	R7140G,L,M RM7800E,G,L,M; RM/EC7823A; RM7838A,B; RM7840E,G,L,M; RM/EC7890A,B; RM/EC7895A,B,C,D	—	—	1.25	5.0
C7012E,F ^e	R7247C ^c Dynamic Self-Check	R4075C,D,E ^g ; R4138C,D ^g ; R4140G,L,M; BC7000L	2.0	7.0	—	—
	R7747C ^d Dynamic Self-Check	BCS7700	—	—	2.2	4.98
	R7847C ^f Dynamic Self-Check	R7140G,L,M RM7800E,G,L,M; RM/EC7823A; RM7838A,B; RM7840E,G,L,M; RM/EC7890A,B; RM/ EC7895A,B,C,D	—	—	1.25	5.0 (1.5 Vdc with Series 4 or greater) ^f
C7012G	R7321A,B	R4140J,K ^g	2.0	6.0	—	—

^a This minimum or greater signal should be obtained if the detector is correctly installed and positioned to properly sense flame. This current or voltage must be obtained before completing the Checkout.

^b The circuitry tests ONLY the flame signal amplifier during burner operation and shuts down the burner if the amplifier fails.

^c Set selector switch on W136A Volt-ohmmeter to SPL (damped) position to read current.

^d Shutter operates ten cycles per minute.

^e Shutter operation of the C7012E,F causes fluctuations in the current reading. Read the average stable current or voltage, disregarding the peaks.

^f Shutter operates 12 cycles per minute (Series 1,2,3 Amplifiers). Series 4 or greater amplifiers, shutter operates when flame signal of 1.5 Vdc is sensed. Readings will be constantly changing, usually between 0.9 to 2.3 Vdc on the S7800 Keyboard Display Module.

^g Currently obsolete.



TROUBLESHOOTING

WARNING

**Electrical Shock Hazard.
Can cause serious injury or death.**

Be extremely careful while troubleshooting the detector; line voltage is present on some of the terminals when power is on.

Open the master switch to disconnect power before removing or installing the detector or its cover. More than one disconnect can be involved.

Equipment Required

1. Use Honeywell W136A Volt-ohmmeter with a zero to 25 microampere scale to check out most Honeywell flame safeguard controls.
2. Use 196146 Meter Connector Plug provided with the W136A.
3. To measure the flame signal of the BCS 7700 control, a volt-ohmmeter with a minimum sensitivity of 20,000 ohms/volt and a zero to five Vdc or zero to ten Vdc scale is recommended. When the Keyboard Display Module is included with the control, the module displays a flame signal.
4. For 7800 SERIES controls, a ohm/voltmeter with an input impedance of one megohm/volt and a zero to five or ten Vdc scale is suggested. When the Keyboard Display Module is included with the control, the module displays a flame signal.
5. For replacement parts, see Specifications section.

UV Sensor Tube Test

See UV Sensor Tube Test in Adjustments and Checkout.

Unsatisfactory Flame Signal

If a satisfactory flame signal (see Table 1) cannot be obtained while adjusting the sighting position of the detector, follow these procedures. If you encounter other problems in the system, refer to the Troubleshooting section in the instructions for the appropriate flame safeguard control.

NOTE: For instructions for replacing the viewing window, sensing tube, and coil and shutter assembly, see the Service section.

Troubleshooting Procedures

First perform the Preliminary Inspection. Then follow the applicable procedures for either a low reading or a zero reading on the meter. After reinstalling the detector or replacing

its cover, recheck the meter reading. To try to obtain the proper flame signal, adjust the position of the detector. If you complete all of the procedures and cannot yet obtain a proper flame signal, replace the detector.

Preliminary Inspection

1. Check for the proper line voltage. Make sure the master switch is closed, connections are correct, and power supply is of the correct voltage and frequency.
2. Check the detector wiring for defects:
 - a. Incorrect connections.
 - b. Wrong type or size of wire.
 - c. Deteriorated wire.
 - d. Open circuits.
 - e. Short circuits.
 - f. Leakage paths caused by moisture, soot, or dirt.
3. With the burner running, check the temperature at the detector. If it exceeds 175°F (79°C):
 - a. Add additional insulation between the wall of the combustion chamber and the detector.
 - b. Add a shield or screen to reflect radiated heat away from the detector, or
 - c. Add cooling (refer to Sight Pipe Ventilation and Accessories sections).

Removing Detector from the Sight Pipe

For C7012A,E or G (refer to Fig. 9); loosen the three screws holding the mounting flange; rotate the detector slightly so the screws clear the slots in the back section of the flange; separate the flange; and pull off the back section (with the UV sensor).

For C7012C or F (refer to Fig. 10); unscrew the collar from the pipe union and remove the detector.

NOTE: The detector is free when the collar is unscrewed; *do not drop it.*

Procedure for a Zero Meter Reading

1. Replace the plug-in amplifier (if included). Then recheck the flame signal.
2. Replace the ultraviolet sensing tube (see Service section). Then recheck the flame signal.
3. For a C7012E or F, replace the coil and shutter assembly (see Service section). Then recheck the flame signal.
4. If you still cannot obtain a meter reading, replace the detector.

IMPORTANT

At the completion of Troubleshooting, be sure to perform the Adjustments and Checkout procedures.



C7012A,C,E,F,G SOLID STATE PURPLE PEEPER® ULTRAVIOLET FLAME DETECTORS

SERVICE

! WARNING**Electrical Shock Hazard.****Can cause serious injury or death.**

Open the master switch to disconnect power before removing or installing the detector or its cover. More than one disconnect can be involved.

Periodic Maintenance

1. Clean the viewing window (or focusing lens) when necessary. Remove the detector (see Troubleshooting section) and use a clean cloth over the eraser end of a pencil. Do not remove the window (or lens) to clean it. If it is broken or damaged or is coated with a substance that cannot be removed, replace it (see Fig. 24).
2. Keep the flame detection system adjusted for the smoothest, most reliable operation as recommended by the burner manufacturer.
3. Replace the sensing tube, coil and shutter assembly, or viewing window only when necessary to obtain proper operation.

Removing Detector Cover (All Models)

1. Open the master switch.
 - a. C7012A,E OR G: Unscrew the four captive cover screws (Fig. 7) and carefully slide off the cover.
 - b. C7012C OR F: Unscrew the six hex-head cover bolts (Fig. 8) and carefully pull off the cover.

NOTE: These bolts are removable. Put them in a safe place so you do not lose them.

Replacing Ultraviolet Sensing Tube (All Models) (Fig. 20)

1. Open the master switch and remove the cover from the detector (see instructions above).
2. Locate the UV sensing tube.

IMPORTANT

On a C7012E or F, be careful not to kink or otherwise damage the flexible shutter.

3. On a C7012E or F, gently bend the alignment guide just enough to free the tip of the tube.
4. Insert a screwdriver between the tube base and the socket, and gently pry the tube out of its socket.
5. Pull the tube completely out of its socket (and out of the shutter assembly on a C7012E or F).
6. On a C7012E or F, insert the new tube through the openings in the shutter assembly.
7. Align the three pins on the new tube with the holes in the socket.
8. Carefully push the new tube firmly into the socket. (On a C7012E or F, the alignment guide snaps into place around the tip of the tube.)
9. Make sure the new UV sensor tube is seated securely.

NOTE: The cover for a C7012C or F has a small hole that is keyed to a pin on the body flange (Fig. 8).

10. Replace the detector cover.

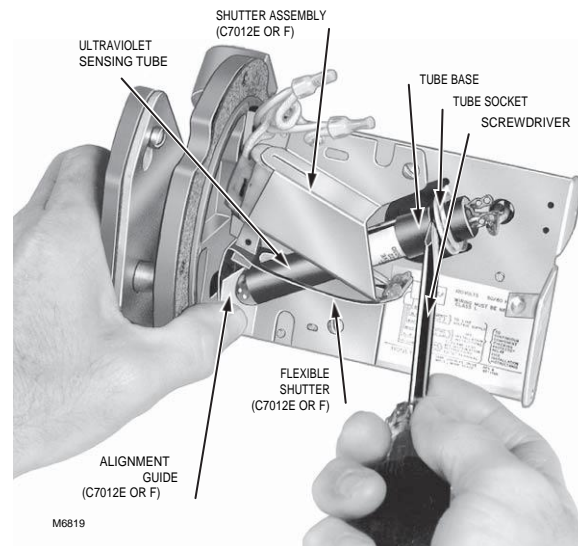

Fig. 21. Replacing ultraviolet radiation sensing tube.

Replacing Coil and Shutter Assembly (C7012E,F Only) (Fig. 21)

NOTE: Use only a 190971B Coil and Shutter Assembly. This assembly can also be used on existing C7012 Detectors with electronic tubes. The actual operating voltage of the coil is either 110V or 120V, depending on the primary control used in the system.

1. Open the master switch and remove the detector cover (see Removing the Detector Cover section).
2. Remove the ultraviolet sensing tube (steps 1 through 5 of Replacing the Ultraviolet Sensing Tube section).
3. Cut the white wires as close as possible to the crimped connectors, and remove the crimped connectors.
4. Remove the three mounting screws from the base of the coil and shutter assembly and put in a safe place.
5. Remove the coil and shutter assembly.
6. Put the new coil and shutter assembly into place.

IMPORTANT

Be very careful not to kink or otherwise damage the flexible shutter.

7. Insert the three mounting screws into the base of the coil and shutter assembly and tighten securely.
8. Remove sufficient insulation from each of the two white leadwires remaining on the detector, and also from each of the two white leadwires on the new coil.
9. Using solderless connectors, connect one of the coil wires to one of the remaining white leadwires. Connect the other coil wire to the other remaining white leadwire.
10. Reinstall the sensing tube (steps 6 through 9 of Replacing the Ultraviolet Sensing Tube section).

NOTE: The cover for a C7012F has a small hole that is keyed to a pin on the body flange (Fig. 9).

11. Replace the detector cover.



C7012A,C,E,F,G SOLID STATE PURPLE PEEPER® ULTRAVIOLET FLAME DETECTORS

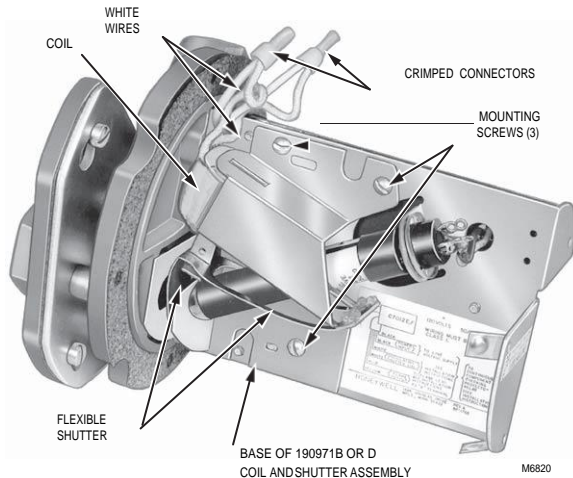

Fig. 22. Replacing coil and shutter assembly on C7012E,F.

Replacing Quartz Viewing Window (or Focusing Lens)

IMPORTANT

Use quartz window or lens. Ordinary glass absorbs or filters out ultraviolet radiation.

C7012A,E,G (Fig. 22)

- 1. Open the master switch; remove the detector from the sight pipe and remove the detector cover. (See appropriate sections.)
2. Remove the ultraviolet sensing tube (steps 1 through 5 of Replacing the Ultraviolet Sensing Tube section).
3. Loosen the three screws holding the backsection of the mounting flange to the faceplate. Carefully remove and keep together the three screws, the gray asbestos-neoprene gasket, the red rubber washer, and the back section of the mounting flange.

NOTE: If the viewing window (with its rubber mounting gaskets) is stuck to the mounting flange, skip step 4.

IMPORTANT

On a C7012E, be very careful not to kink or otherwise damage the flexible shutter.

- 4. Using the eraser end of a pencil, push out the viewing window (with its rubber mounting gaskets) from the inside of the faceplate.

- 5. Insert one rubber mounting gasket into the window aperture on the faceplate.
6. Insert the new quartz viewing window (or focusing lens) into the window aperture with either side toward the flame.
7. Insert two rubber mounting gaskets (only one gasket when replacing a focusing lens) into the aperture.
8. Put the back section of the mounting flange, rubber washer, and fiber-neoprene gasket into place on the faceplate, and securely tighten the three mounting screws.

NOTE: Make sure the red rubber washer between the gray asbestos-neoprene gasket and the back section of the mounting flange does not protrude over the window aperture or otherwise obscure the line-of-sight of the detector.

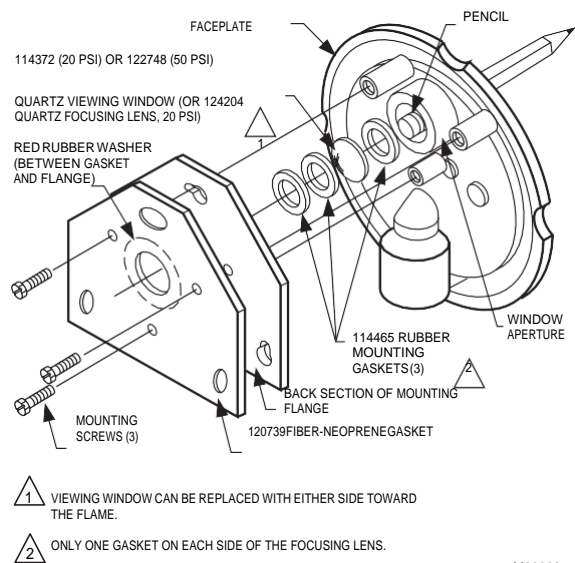

- 1. VIEWING WINDOW CAN BE REPLACED WITH EITHER SIDE TOWARD THE FLAME.
2. ONLY ONE GASKET ON EACH SIDE OF THE FOCUSING LENS.

M20033

Fig. 23. Replacing quartz viewing window or focusing lens on C7012A,E,G.

- 9. Clean the viewing window (or focusing lens) on both sides using a clean cloth placed over the eraser end of a pencil.
10. Reinstall the sensing tube (steps 6 through 9 of Replacing Ultraviolet Sensing Tube section).
11. Replace the detector cover and reinstall the detector on the sight pipe.



C7012A,C,E,F,G SOLID STATE PURPLE PEEPER® ULTRAVIOLET FLAME DETECTORS

C7012C or F (Fig. 23)

1. Open the master switch and remove the detector from the sight pipe (see appropriate section).
2. Unscrew the four hex-head bolts holding the seal-off flange to the faceplate, and remove the flange. Put the bolts in a safe place.
3. Unscrew the retaining ring (with its rubber O-ring seal) from the seal-off flange.
4. Tip the flange and let the viewing window fall into your hand.
5. Insert either side of the new 122037 Quartz Viewing Window into the window aperture.
6. Screw the retaining ring (with O-ring seal) into the seal-off flange and tighten securely.
7. Clean the viewing window on both sides with a clean cloth placed over the eraser end of a pencil.
8. Put the seal-off flange back into place on the faceplate, and securely tighten the four hex-head bolts.
9. Reinstall the detector on the sight pipe.

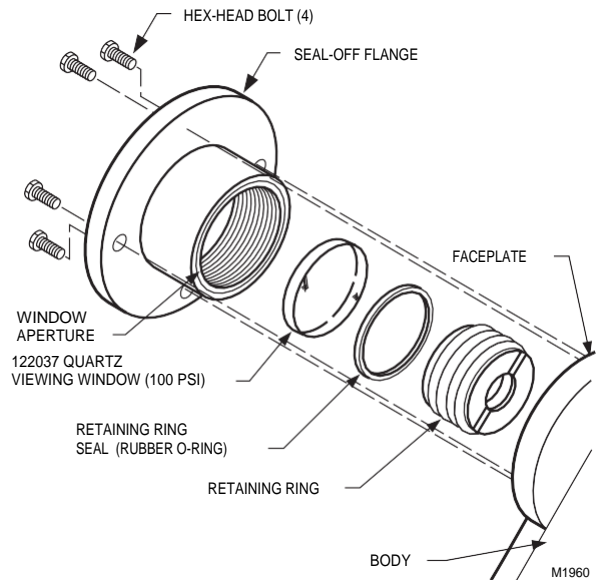

Fig. 24. Replacing quartz viewing window on C7012C,F



บริษัท เอดีดี เฟอร์เนส จำกัด

ADD FURNACE CO.,LTD.

44 ซอยบรมราชชนนี 70 ถนนบรมราชชนนี แขวงศาลาธรรมสพน์ เขตทวีวัฒนา กรุงเทพฯ 10170

โทร: 02-888-3472 โทร: ออกแบบ:08-08-170-170 แฟกซ์: 02-888-3258

<https://www.add-furnace.com> E-mail: sales@add-furnace.com

C7012A,C,E,F,G SOLID STATE PURPLE PEEPER® ULTRAVIOLET FLAME DETECTORS

Automation and Control Solutions

Honeywell International Inc. 1985
Douglas Drive North Golden Valley,
MN 55422 customer.honeywell.com

© U.S. Registered Trademark
© 2011 Honeywell International Inc. 60-
2398—15 M.S. Rev. 06-11
Printed in U.S.A.

Honeywell