

FLAME SWITCH

BC1000 SERIES

PRODUCT HANDBOOK



1. APPLICATION

The BC1000A/B series is a flame switch for intermittent operation to indicate presence or absence of a flame and to be applied in commercial or industrial burner installations. The BC1000A can also be used as a primary control for manually operated burner systems using a start/stop station.

In addition to the flame sensing functions, the BC1000A/B provides a “Safe Start” function which checks if a flame signal is present when applying power to the device. If so, the BC1000A/B holds its operation until the flame signal disappears.

The BC1000A/B can be used with a recifying flame rod or all existing non-selfcheck Honeywell “PowerTube” type UV sensors (for intermittent operation only).

The BC1000 (FR models) will operate also with the ex-Satronic IRD810/1010 range of infrared sensors. Note that this combination is NOT CE approved for use on installations that fall under the GAD (Gas Appliances Directive).

2. FEATURES

- 1) Compact design.
- 2) Plug-in wiring sub base for direct panel or DIN RAIL mounting.
- 3) Safe-start check (SSC) feature prevents operation when abnormal flame condition exists at start-up.
- 4) LED indication (Power, Flame, SSC) on the front to show operation status (SSC hidden behind the front cover).
- 5) Screw terminals on the front provide continuous 0-6VDC flame signal strength monitoring.

Contents

1. Application	1
2. Features	1
3. Specifications	2
4. Appearance and Dimensions.....	3
5. Installation and Wiring	4
6. Operation and Sequence.....	8
7. Approvals.....	9
8. Sales affiliates in Europe	10

3. SPECIFICATIONS

Table 1: Model Selection Guide

Model	Rated voltage	Power consumption	Flame Response time	Flame sensor	Safety-start check output	Flame output
BC1000A0110F	115V 50/60Hz	5W	2 ± 1 sec.	Flame rod or C7012A/G	SPST (T3-4)	SPST (T2-3)
BC1000A0110U	115V 50/60Hz	8W	2 ± 1 sec.	C7027/35/44	SPST (T3-4)	SPST (T2-3)
BC1000A0220F	230V 50/60Hz	5W	2 ± 1 sec.	Flame rod or C7012A/G	SPST (T3-4)	SPST (T2-3)
BC1000A0220U	230V 50/60Hz	8W	2 ± 1 sec.	C7027/35/44	SPST (T3-4)	SPST (T2-3)
BC1000B1000	115V 50/60Hz	5W	Max. 1 sec.	Flame rod or C7012A/G	None	SPDT (T2...4)
BC1000B1018	230V 50/60Hz	5W	Max. 1 sec.	Flame rod or C7012A/G	None	SPDT (T2...4)
BC1000B2001	115V 50/60Hz	8W	Max. 1 sec.	C7027/35/44	None	SPDT (T2...4)
BC1000B2019	230V 50/60Hz	8W	Max. 1 sec.	C7027/35/44	None	SPDT (T2...4)

Table 2: Electrical and Environmental Ratings

Item	Specification
Rated voltage	110..115Vac or 220..230Vac, 50/60Hz -15 ~ +10%
Allowable ambient temperature	Stand-alone mounting: -20 ~ +60°C Parallel mounting (2 or more sets) : -20 ~ +45°C
Protection Class	IP00 (mount inside cabinet)
Allowable ambient humidity	Max. 90% RH non condensing
Vibration resistance	0.5G (10 to 150Hz for 1h each in x,y and z directions)
Insulation resistance	More than 50MΩ at DC500V between terminals and ground
Life expectancy	Designed for 10 years of operation or 250.000 cycles under nominal conditions
Terminal ratings	Relay output max 1A @ cosφ=1,0 per terminal
Flame strength	Flame On : > 1V Flame Off : < 0.2V
Size (WxHxD)	42.5 x 90.0 x 95.5 mm (including sub-base)
Weight	Approx. 334g (including sub-base)

* Keep min. 50mm distance from the top and min. 20mm left/right/bottom around the device.

4. APPEARANCE AND DIMENSIONS

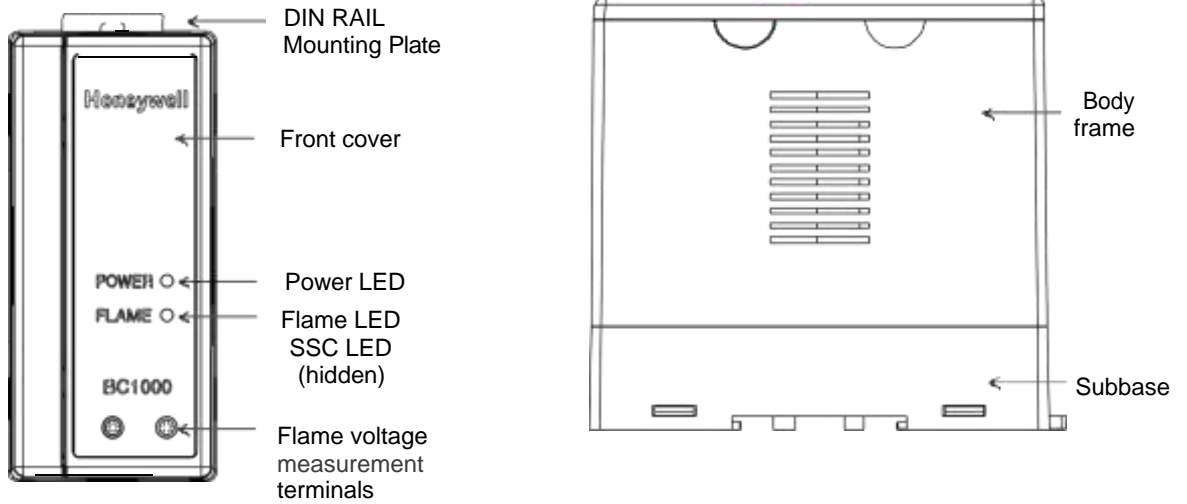

Fig. 1: Appearance

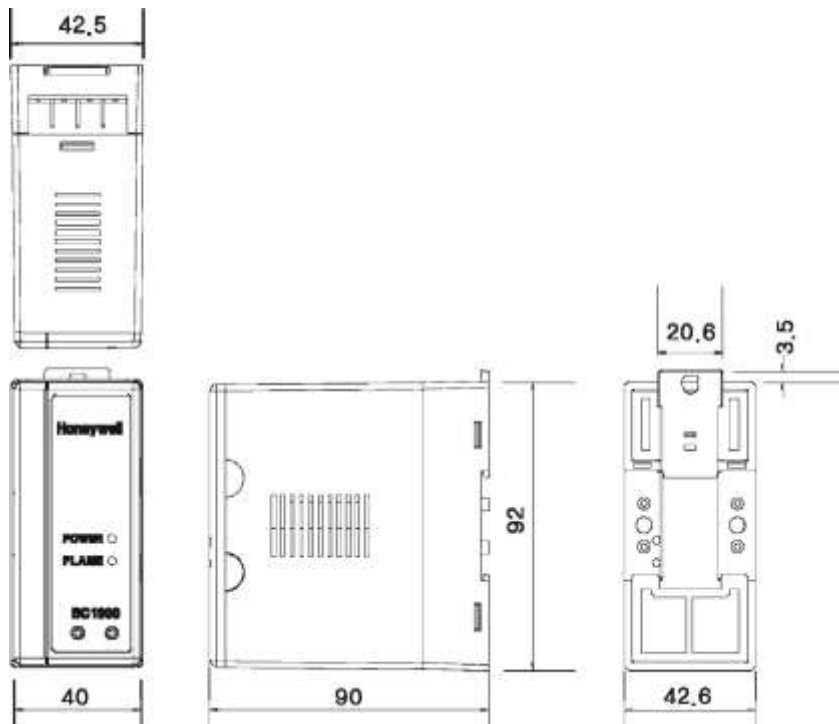

Fig. 2: External Dimensions (in mm)

5. INSTALLATION AND WIRING

CAUTION

INSTALLATION

When Installing this Product...

- 1) Read these instructions carefully. Failure to follow them could damage the product or cause a hazardous condition.
- 2) Check the ratings given in the instructions and marked on the product to make sure the product is suitable for the application.
- 3) Installer must be a trained, experienced, flame safeguard service technician.
- 4) After installation is completed, check out the product operation as provided in these instructions.



WARNING

Fire or Explosion Hazard.

Can cause property damage, severe injury, or death.

Carefully follow safety requirements when installing a burner control.



CAUTION

Electrical Shock Hazard or Equipment Damage.

Disconnect power supply before beginning installation to avoid an electrical shock or equipment damage.



IMPORTANT

- 1) Do not install the Flame Switch under any circumstances in the following locations:
 - a. Where chemicals or corrosive gases are present, such as ammonia, sulfur, chlorine, ethylene compounds, acids, etc.
 - b. Where the relative humidity reaches the saturation point. The relay module is designed to operate in a maximum 85% relative humidity continuous, noncondensing, moisture environment. Condensing moisture can cause a safety shutdown or damage the device.
 - c. Where vibration exceeds 0,5G continuous vibration or temperatures exceed the maximum specification for this device.
- 2) Disconnect the power supply from the main disconnect before beginning installation to prevent electrical shock and equipment damage. Supply power to BC1000 after finishing all wiring and completing proper checks.
- 3) Do not overload the BC1000 terminal rating.
- 4) Do not bundle the lead wires for mains, ignition transformer's HIGH-VOLTAGE and flame detector. The min. distance between the BC1000 and the HV ignition cable is 10cm.
- 5) Use proper grounding work in accordance with the engineering standards for electrical equipment.
- 6) After deenergizing the BC1000, residual charge may be present on terminal 5 (F lead of the flame detector).
- 7) BC1000 verifies that a flame or flame simulating condition exists at start-up. BC1000 can be used in intermittent operation only, i.e a controlled stop/start must occur at least once every 24 hours of operation.

SEPARATION AND INSTALLATION OF RELAY MODULE AND THE SUB BASE

- 1) Remove the front cover as shown in Fig. 1 and unscrew the Phillips head fixing screw by about 8 turns CCW.
- 2) Gently pull the relay module from its socket. Don't use excessive force to avoid damage to the device.
- 3) Position the sub base and mount by fastening screws.



IMPORTANT

Do not over-tighten the central fixation screw to avoid damage to the (Phillips) head of the screw. So called "hand-tight" is good enough to fixate the BC1000 properly onto its sub base.

* If using the DIN RAIL mounting option, refer to Fig. 4.

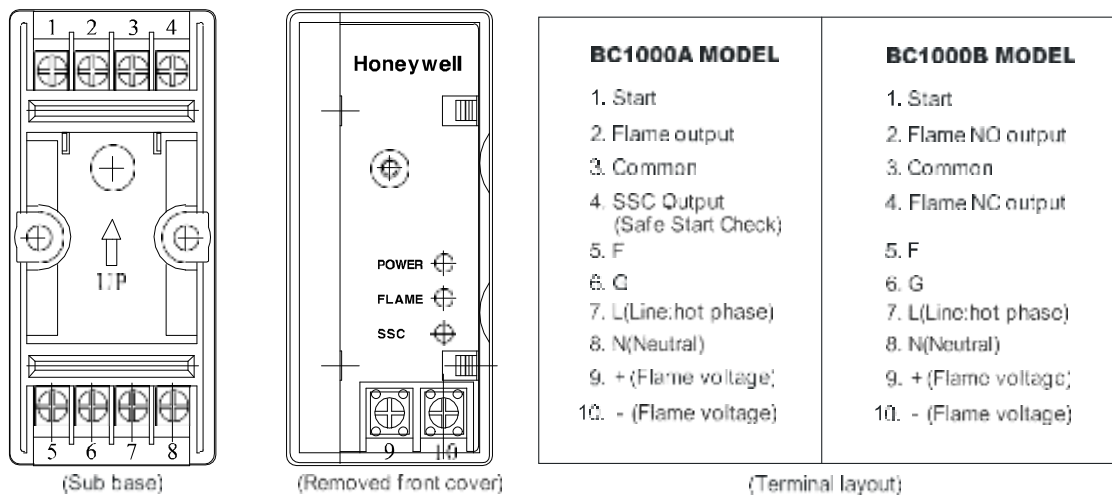

Fig. 3: Sub base terminals and front terminals



CAUTION

Although the voltage on front terminals are of low voltage, it is not considered to be safe when touching these wires, in case of a malfunction of the device. Therefore avoid touching these terminals and its connected lead wires to avoid an electrical shock.

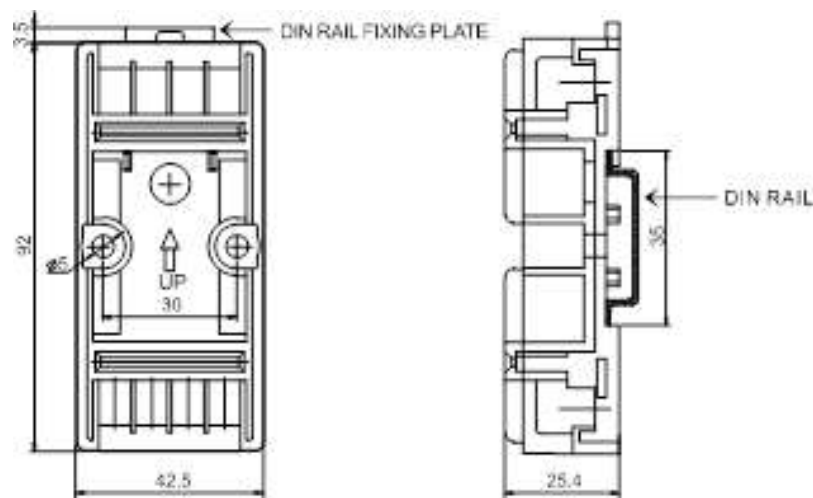
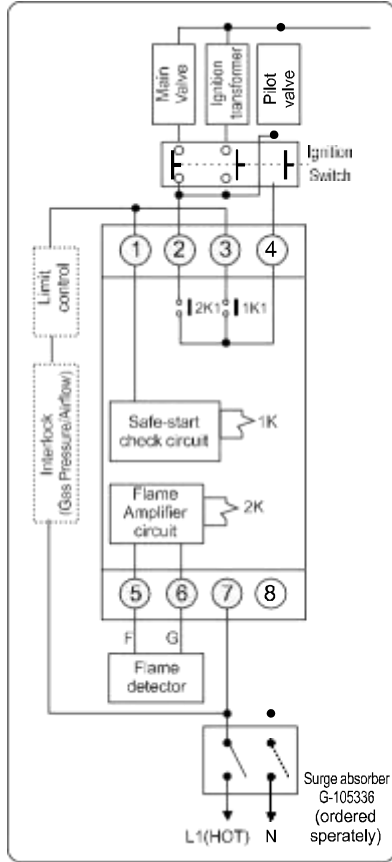

Fig. 4: Dimensions (DIN RAIL mount)

SUB BASE WIRING

① Manual Ignition (Intermittent pilot)
 BC1000A Model (Except BC1000B)



② Flame Monitoring

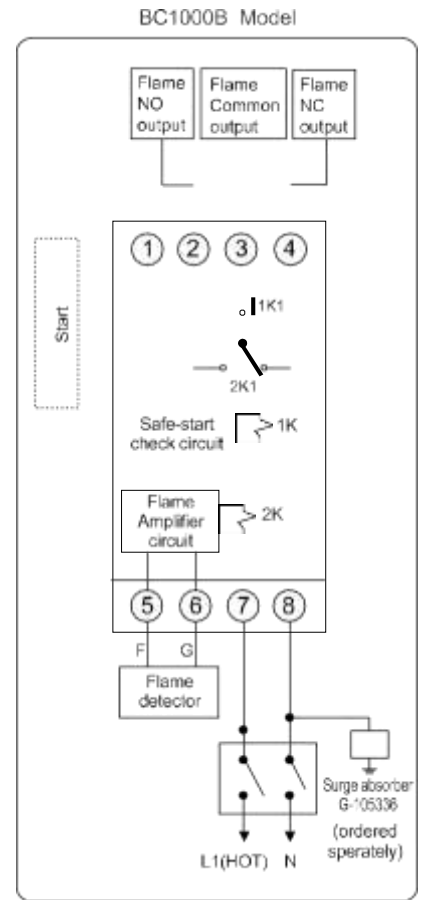
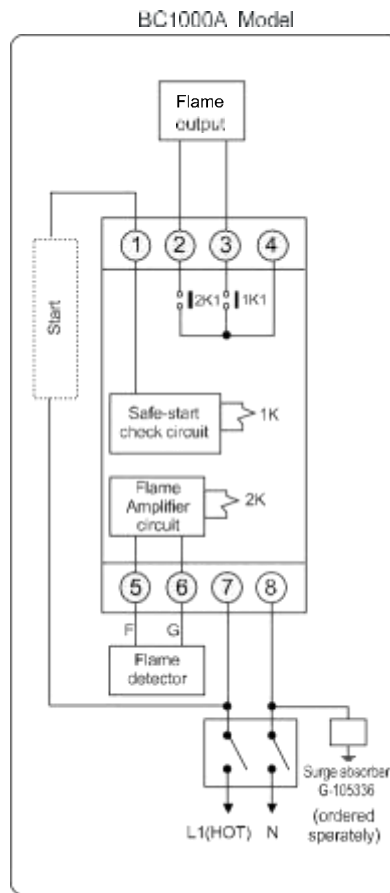

Fig. 5: Example of wiring to external devices

- 1) Fig. 5 is an example of typical wiring diagrams. Refer Fig. 2 for terminal location
- 2) Internal relay operation

BC1000A MODEL	BC1000B MODEL
<ol style="list-style-type: none"> 1. Safe-start check circuit verifies that a flame or flame simulating condition exists when powering up the terminal 1 of the device. <ul style="list-style-type: none"> - No flame: Safety relay closed (1K1 close) - Flame: Safety relay remains opened (1K1 open) until the flame disappears (hold condition) 2. Flame amplifier circuit controls the flame relay. <ul style="list-style-type: none"> - No flame: Flame relay opened (2K1 open) - Flame: Flame relay closed (2K1 close) 	<ol style="list-style-type: none"> 1. Safe-start check circuit verifies that a flame or flame simulating condition exists when powering up the terminal 1 of the device. <ul style="list-style-type: none"> - No flame: Safety relay closed (1K1 close) - Flame: Safety relay remains opened (1K1 open) until the flame disappears (hold condition) 2. Flame amplifier circuit controls the flame relay. <ul style="list-style-type: none"> - No flame: Flame relay NC output is closed (2K1 NC) - Flame: Flame relay NO output is closed (2K1 NO)

HOW TO INSTALL THE FLAME DETECTOR

To check the correct installation location of the flame detector, the flame signal strength can be measured using a multimeter. Connect the multimeter to the (+) and (-) terminals located at the front.

The minimum recommended voltage is 2VDC, while the maximum value is limited to 6VDC. Adjust the optimal position of the flame detector. For instructions to install Honeywell UV flame detector, refer to the instruction sheet of C7027/C7035/C7044 flame detectors.

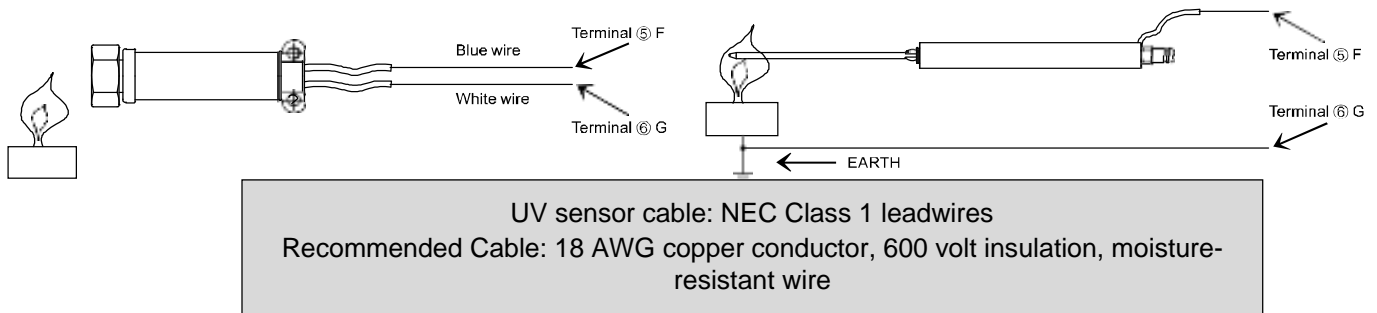

Fig. 6: Flame detector wiring



Always use cable lugs to attach the wires to the sub base

See Fig 6-1 for dos and don'ts about wiring.

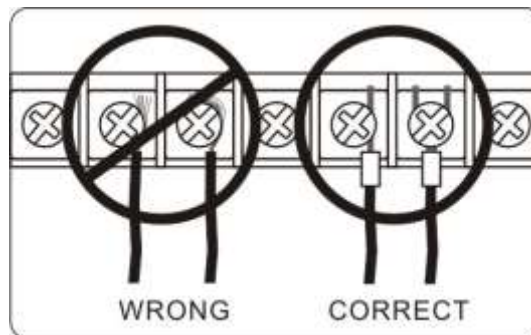

Fig. 6-1: Wiring the sub base terminals

6. OPERATION AND SEQUENCE

a. Manual Ignition System with Intermittent Pilot (refer to Fig. 5 ①Manual Ignition)

LED DISPLAY		STANDBY	SAFE-START	PFEP④	RUN	STANDBY
	POWER	● POWER	● POWER	● POWER	● POWER	● POWER
	FLAME	○	○	● FLAME	● FLAME	○
	SSC	○	● SSC	● SSC	● SSC	○
Ignition switch				Ignition switch		
Pilot				Intermittent pilot ③		
Main Valve					Main valve ②	
Limit / interlock				limit / interlock closed		
Flamesignal			Safe-start check ①		Flame monitoring	

1. If flame is detected before safe-start check is completed, operation is put on hold until the flame signal disappears. (① in upper table)
2. If flame is lost during RUN, the flame relays are de-energized. (②③ in upper table)
3. Pilot flame establishing period(PFEP) should comply with the application standards. (④ in upper table)

b. Flame Monitoring System (normal operation, refer to Fig. 5 ②Flame Monitoring)

LED DISPLAY		STANDBY	SAFE-START	FLAME MONITORING				STANDBY
	POWER	● POWER	● POWER	● POWER	● POWER	● POWER	● POWER	● POWER
	FLAME	○	○	○	● FLAME	○	● FLAME	○
	SSC	○	● SSC	● SSC	● SSC	● SSC	● SSC	○
Flame on				②	③	②	③	
Start				Start input (Safe-start check operation)				
Flame signal			Safe-start check ①	No flame	Flame	No flame	Flame	

1. If flame is detected before safe-start check is completed, output relays are operated as below until the flame signal disappears. (① in upper table)
BC1000A Model: 1K1 relay open and 2K1 relay close (T2-T4 closed)
BC1000B Model: 1K1 relay open and 2K1 relay NO (T3-T2 & T3-T4 opened)
2. If flame is lost during operation, output relays are operated as below. (② in upper table)
BC1000A: 1K1 relay close (T3-T4 closed) and 2K1 relay open (T2-T3 opened)
BC1000B: 1K1 relay close and 2K1 relay NC (T3-T2 opened, T3-T4 closed)
3. If flame is detected during operation, output relays are operated as below. (③ in upper table)
BC1000A: 1K1 relay close (T3-T4 closed) and 2K1 relay close (T2-T3 closed)
BC1000B: 1K1 relay close and 2K1 relay NO (T3-T2 closed, T3-T4 opened)

7. Approvals

Honeywell Technologies Sàrl
Z.A. La Pièce 16
1180 Rolle
Switzerland

declares under its sole responsibility that the following product family of **flame switches**:

BC1000 A xxxx, BC1000 B xxxx

to which this statement relates, is:

- in conformity with the essential requirements of the **Gas Appliance Directive 2009/142/EC**

based on EN 298

and in conformity with the type as described in the EC type-examination certificate issued by TÜV Rheinland InterCert Kft with pin numbers:

- BC1000A0220F: 1009BU1560
- BC1000A0220U: 1009BU1561
- BC1000A0110U, BC1000A0110F and BC1000Bxxxx: 1008CM2504

- in conformity with the essential requirements of the **Low Voltage Directive 2006/95/EC**

based on EN 60730-2-5

- in conformity with the essential requirements of the **EMC Directive 2004/108/EC** on immunity

based on EN 298 immunity requirements

Conformity with the essential requirements of the **EMC Directive 2004/108/EC** on emission can only be determined in the application.

This product is under surveillance at KIWA Nederland BV.

Emmen, August 2011

Signed for and on behalf of Honeywell Technologies Sàrl,

A.Veld

Manager Standards & Approvals

บริษัท:	บริษัท เอดีดี เฟอร์เนส จำกัด Add Furnace Co.,Ltd.
ที่อยู่:(bangkok)	44 ซ.บรมราชชนนี 70 ถ.บรมราชชนนี ศาลาธรรมสพน์ ทวีวัฒนา กทม. 10170.
website:	https://www.add-furnace.com/
e-mail:	sales@add-furnace.com add028883472@gmail.com
โทร.(ออกแบบ):	08-08-170-170, 088-300-1122
โทร:	02-888-3472
Online Support:	Line ID: @add11 Wechat ID: add0883001122
แฟกซ์:	02-888-3258
 line ID:	@add11