



บริษัท เอดีดี เฟอร์เนส จำกัด

ADD FURNACE CO.,LTD.

44 ซอยบรมราชชนนี 70 ถนนบรมราชชนนี แขวงศาลาธรรมสพน์ เขตทวีวัฒนา กรุงเทพฯ 10170

โทร: 02-888-3472 โทร: ออตกเบบ:08-08-170-170 แฟกซ์: 02-888-3258

https://www.add-furnace.com E-mail: sales@add-furnace.com

Honeywell

SLATE™ Low Torque Actuator Series

FOR COMMERCIAL AND INDUSTRIAL MODELS
R8001M1050/U, R8001M1150/U, R8001M4050/U,
R8001M4150/U

INSTALLATION INSTRUCTIONS

FEATURES AND BENEFITS



SLATE Commercial Model

- Offered in two different configuration options:
 - NEMA 1 rated, operating in a temperature range of -18 to 158 °F (-28 to 70 °C) with 450 positions over a 90° span
 - NEMA 4 rated, operating in a temperature range of -40 to 158 °F (-40 to 70 °C) with 900 positions over a 90° span
- Field-reversible clockwise and counterclockwise rotation operation.
- Internal temperature, valve status, health diagnostics, and error codes reporting.
- Robust, heavy-duty construction, continuous duty cycle-rated.
- Closed loop position control via Modbus RS-485 communications as an input to the SLATE Fuel Air Ratio Module, part R8001C6001.
- Dual 1/2-in knockout conduit connections.
- 1/2-in keyed output shaft with a 1/8-in square key.
- Die-cast aluminum base with high-impact resistant, reinforced plastic cover.
- Meets UL353 Safety for Limit Controls.
- Meets UL1998 when used with R8001C6001 SLATE Fuel Air Ratio Module.

APPROVALS

Underwriters Laboratories	Meets UL353 Safety for Limit Controls. Meets UL1998 when used with R8001C6001 SLATE Fuel Air Ratio Module.
CE	2009/142/EC: Gas Appliance Directive (EN 12067-2:2004, EN298-2012)

APPLICATION

SLATE brings configurable safety and programmable logic together into one single platform. The SLATE program can easily be customized for almost any application—offering virtually limitless development opportunities with far less complexity.

The SLATE Low Torque Actuator series includes commercial and industrial-grade 1/4-turn actuators available in 50 and 150 in/lb models with highly repeatable position accuracy designed specifically to integrate with the SLATE system. This series is well suited for the precise control of air and gas flow and can operate in a wide range of temperatures and environmental conditions.

SLATE™ Low Torque Actuator can be easily mounted to the following valves using the mounting kits noted below. These kits can be ordered via www.customer.honeywell.com.

- Maxon CV Valve Series (1/2"–2") mounting kit #50123928-001
- Honeywell V51E Valve Series (1-1/2"–2") mounting kit #50124386-001 and mounting kit #32003396-001
- Honeywell V51E Valve Series (2-1/2"–4") mounting kit #50124386-001 and mounting kit #32003396-002
- Honeywell V5197A Valve Series (3/4"–3") mounting kit #50124386-001



32M-06009-05



SLATE™ LOW TORQUE ACTUATOR SERIES

SPECIFICATIONS

Supply Voltage (Peak Current):

DC model: 24VDC +10/-20%

Power:

50 in/lb: 10 Watts maximum

150 in/lb: 25 Watts maximum

Rotation: Max span: 90° usable**Resolution:**

Commercial: 450 positions (0.2° resolution)

Industrial: 900 positions (0.1° resolution)

Control Deadband:

Commercial: ±0.2 degrees

Industrial ±0.1 degrees

Dimensions in in (mm): 6-11/16 x 5-29/64 x 5-29/64

(170 x 138 x 138); See Fig. 1

Weight: 3 Lbs. (1.4 Kg)**Operating Temperature:**

-28 to +70 °C (-18 to +158 °F) for commercial models;

-40 to +70 °C (-40 to +158 °F) for industrial models

Storage Temperature: -40 to +80 °C (-40°F to +176°F)**Relative Humidity:**

0 to 99% non condensing (for commercial models)

Vibration: Honeywell V2 test specification; 3 axes tested as follows:

2- Hour Performance/Resonant Detection Sweep:

Vibration sinusoidal: 5 Hz - 30 Hz;

Amplitude: 0.012mil pk/pk/75 mm

Vibration sinusoidal: 30 Hz - 300 Hz at 0.6G

Endurance: 1.1G for 2 hours at resonant frequencies

EMC: EN61000-6-1/2/3 (See Safety and Agency Approval Requirements), FCC Part 15, Level A EN55022, Level A**Enclosure:**

NEMA1 (commercial models)

NEMA 4 (industrial models)

Models:

Model Number	Description
Commercial	
R8001M1050	50 in/lb Actuator NEMA 1 Enclosure
R8001M1150	150 in/lb Actuator NEMA 1 Enclosure
Industrial	
R8001M4050	50 in/lb Actuator NEMA 4 Enclosure
R8001M4150	150 in/lb Actuator NEMA 4 Enclosure

Table 1. Model Specifications.

Actuator Options/Specs	Commercial Model		Industrial Model	
	50 in-lb R8001M1050	150 in-lb R8001M1150	50 in-lb R8001M4050	150 in-lb R8001M4150
Communication	RS-485 non-isolated	RS-485 non-isolated	RS-485 Isolated	RS-485 Isolated
Fault Annunciation	Generic Alarm	Generic Alarm	Yes	Yes
Enhanced Data Logging	None	None	Yes	Yes
Resolution	.2 Degree	.2 Degree	.1 Degree	.1 Degree
Repeatability	.2 Degree	.2 Degree	.1 Degree	.1 Degree
Duty Cycle (Act Availability)	100%	100%	100%	100%
Opening Span	90 Degrees	90 Degrees	90 Degrees	90 Degrees
90 Degree Travel Time	30 sec	30 sec	15 sec max	15 sec max
Minimum Operating Temperature	-28 °C (-18 °F)	-28 °C (-18 °F)	-40 °C (-40 °F)	-40 °C (-40 °F)
Maximum Operating Temperature	70 °C (158 °F)	70 °C (158 °F)	70 °C (158 °F)	70 °C (158 °F)
Temp Sensor	Yes; Alarm Only	Yes; Alarm Only	Yes; Alarm and Real Time Data	Yes; Alarm and Real Time Data
Output	1/2-in Keyed Output Shaft	1/2-in Keyed Output Shaft	1/2-in Keyed Output Shaft	1/2-in Keyed Output Shaft
Keyed Connection	1/8-in Square Key	1/8-in Square Key	1/8-in Square Key	1/8-in Square Key
Conduit Connections	1/2-in Conduit Knockouts (2) (Shipped Closed)	1/2-in Conduit Knockouts (2) (Shipped Closed)	1/2-in Conduit Knockouts (2) (Shipped Closed)	1/2-in Conduit Knockouts (2) (Shipped Closed)

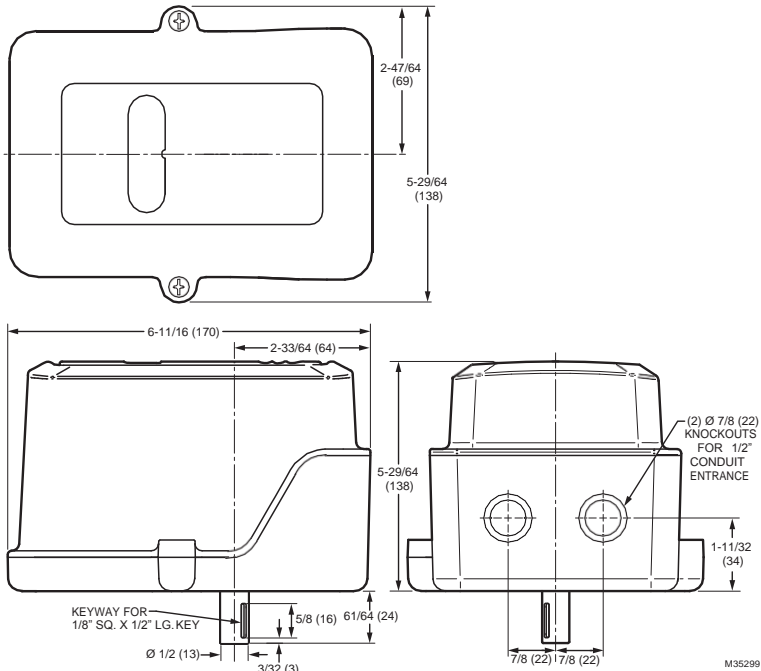

Fig. 1. Dimensions in in (mm).

INSTALLATION INSTRUCTIONS

⚠ WARNING

Read Carefully

Please read the operating and mounting instructions before using the equipment. Install the equipment in compliance with the prevailing regulations.

Bedrijfs- en montagehandleiding voor gebruik goed lezen! Apparaat moet volgens de geldende voorschriften worden geïnstalleerd.

Lire les instructions de montage et de service avant utilisation! L'appareil doit impérativement être installé selon les réglementations en vigueur.

Betriebs- und Montageanleitung vor Gebrauch lesen! Gerät muß nach den geltenden Vorschriften installiert werden.

NOTICE

Language translations for this document are available at www.customer.honeywell.com.

Safety requirements

⚠ WARNING

Safety Notice

The SLATE Actuator has been independently evaluated by Underwriters Laboratories to provide position feedback to the SLATE Fuel Air Ratio Module. The safety of the overall system is ultimately the responsibility of: 1) The upstream safety control that commands and monitors the SLATE Actuator, and 2) the trained commissioning engineer that configures the unit for system operation.

⚠ WARNING

Safety Hazard

Before operating this product, check all specifications and safety requirements to ensure the product is suitable and safe for the intended application. In addition, read all installation, commissioning, and operating instructions. The SLATE Actuator must be set up and maintained in the field by qualified personnel. If the equipment is used in a manner not specified, the protection provided by the equipment may be impaired.



SLATE™ LOW TORQUE ACTUATOR SERIES

Mounting

The actuator assembly may be installed in any orientation.

WARNING

Keep Free of Dust and Water

- Maintain the integrity of the enclosure by using NEMA 4X rated dust- and water-tight electrical connectors.
• Use cable-sealing grips and strain-relief loops for any cord or cable.
• Plug unused conduit holes. Use internal sealing materials on all conduit connections. Moisture can have a harmful effect on device internals if permitted to enter through wiring connectors.
• Ensure that the device connection is not at a low point of the conduit to avoid condensation run-off into the housing; install a drip loop if necessary.
• All cover screws should be tightened to the specified torque. See Fig. 4.
• Cover screws should be checked periodically to ensure adequate sealing protection.

If you are mounting the SLATE™ Low Torque Actuator using third party valves, it is important to follow the following assembly instructions:

- 1. Ensure that the SLATE™ Low Torque actuator has sufficient torque for the valve's required break-away torque. Also consider the line pressure when making this calculation.
2. Turn off the fuel supply upstream from the applicable valve.
3. Remove all external hardware from the third party valve.
4. The SLATE actuator's shaft is 1/2-in. diameter with a 1/8-in. square key. For a smaller 3/8-in. valve shaft you must insert an adapter so that the two shafts are concentrically aligned, ensure that the set screws solidly contact both shafts.
5. If the bracket assembly permits, attach the coupling to the valve and the actuator first, ensuring exact alignment. After the coupling is tightened, assemble and tighten the mounting brackets. Do not tighten the mounting brackets first.
6. Observe the actuator while it travels over its entire range and ensure smooth operation. If sticking/binding is observed, or if Slate reports actuator error codes, the actuator shaft is not properly aligned and must be re-adjusted.

Ensure the media temperature cannot exceed the valve or actuator ratings. Use a coupling with thermal breaks if required. If the possibility exists for radiant heating (such as a furnace application), install a thermal barrier.

Ensure that pipe and ductwork are free of debris that could impair valve function.

See Fig. 2 for the locations of the mounting holes. The mounting holes are threaded for M6 x 1 x 1/2-in (12mm) fasteners.

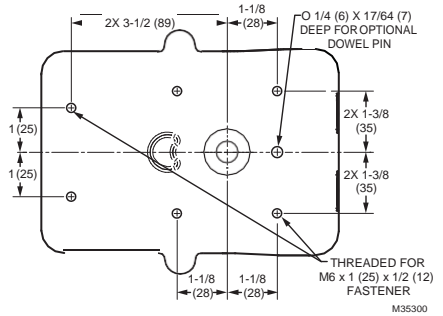

Fig. 2. Mounting holes.

Note the quadrant of the keyway and rotation direction. See Fig. 3.

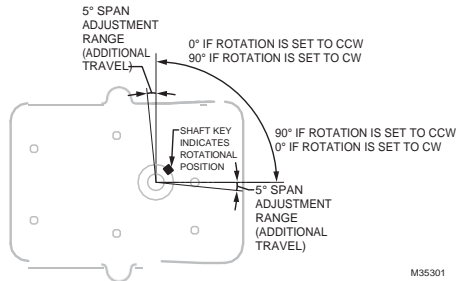

Fig. 3. Actuator rotation direction.

NOTE: The SLATE Actuator ships CCW as default.

Electrical installation

WARNING

Electrical Shock Hazard.

Can cause severe injury, death or equipment damage.

Disconnect the power supply before beginning installation to prevent electrical shock and equipment damage. More than one power supply disconnect can be involved.

Wiring terminals

Fig. 4 indicates each wiring terminal and Table 2 identifies each terminal's signal type and function.



SLATE™ LOWTORQUEACTUATORSERIES

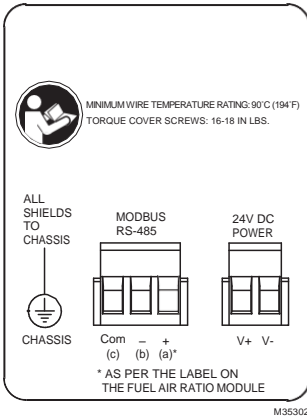

Fig. 4. Wiring terminals.

- In addition to a grounded conduit, the use of shielded, twisted-pair cable is strongly recommended for DC power and signal wires. The shield drain wires should be landed to chassis/earth on both ends of the cable, but ONLY if a conduit is also grounded on both ends. In other cases, earth the shields at actuator end only.

Input power

IMPORTANT

Use DC power only.

Use cable rated for the temperatures and voltages required by the application. Use a gauge of wire to minimize voltage loss (droop) over long cable runs, especially at full current load. Ensure that voltage specifications are met under all conditions. See Table 2.

A fuse or breaker should be installed at the power source. If the power supply is not factory-supplied, a SELV (Safety Extra Low Voltage) rated supply with regulated output must be provided.

Communication (Modbus over RS-485)

Use appropriate communication cable. A network will consist of a customer’s Modbus master (with termination) and one or more actuator slaves. See SLATE documentation for wiring specifics.

NOTE: On commercial models only:

Do not wire the non-isolated common terminal to the Slate system; leave it unconnected. Instead, wire the 24V- of the actuator supply to Pin 2 of the Slate Sub-Base. If all actuators share the same supply, only one connection is needed.

Network layouts should be arranged so that branch/homerun length does not exceed 300 feet for commercial actuators, or 2000 feet for industrial actuators.

To access the field wiring compartment for power and signal connections:

- Remove the 2 screws and cover from the top of the actuator housing.
- Pass all customer-supplied wires into the enclosure through the 2 conduit hubs.

WARNING

Equipment Damage

To ensure physical protection as well as electromagnetic immunity, the use of flexible, sunlight-resistant, jacketed, metallic, water-tight conduit is required. The conduit should be connected to earth ground on both ends.

- One or both conduit holes may be used when wiring an actuator.



SLATE™ LOW TORQUE ACTUATOR SERIES

Table 2. Wiring Terminal Identification.

Type	Terminal	Description	Wiring
PE (Protective Earth)	Chassis ground screw	Chassis connection for mains power and shield/drain wires	Follow local codes for safety earth installation. See Electrical installation section for shield drain installation instructions.
DC power terminals	24V+	24VDC positive terminal	Shielded twisted pair cable is recommended. A replaceable 2A fuse is provided on all actuators. Use a slow blow fuse if additional external fusing is desired. Required gauges are: Up to 80 ft: 24 AWG Up to 120 ft: 22 AWG Up to 500 ft: 16 AWG Up to 800 ft: 14 AWG Up to 1200 ft: 12 AWG
	24V-	24VDC negative terminal	
Low voltage communication (Modbus over RS-485) Industrial models only: R8001M4050, R8001M4150	RS485 In+	Isolated RS-485: positive	Shielded twisted pair cable with a separate common wire is recommended. See Electrical installation section for length limitations. Use 12–24 AWG wire. NOTE: Shield should be tied to chassis at Actuator side; do not connect at SLATE (controller) side.
	RS485 In-	Isolated RS-485: negative	
	RS485COM	Isolated RS-485: common NOTE: Must be connected for reliable performance.	
Low voltage communication (Modbus over RS-485) Commercial models only: R8001M1050, R8001M1150	RS485 In+	Non-isolated RS-485: positive	
	RS485 In-	Non-isolated RS-485: negative	
	RS485COM	Non-isolated RS-485: common See note ¹	

¹ Do not wire the non-isolated common terminal to the Slate system; leave it unconnected. Instead, wire the 24V- of the actuator supply to Pin 2 of the Slate Sub-Base. If all actuators share the same supply, only one connection is needed.



OPERATING INSTRUCTIONS TROUBLESHOOTING

The SLATE Actuator is designed specifically for the SLATE Fuel Air Ratio Module. For actuator operation and programming information, see the SLATE Fuel Air Ratio Module document 32-00006 and other SLATE system documentation (Base Module document 32-00005, and System Checkout guide 32-00016).

CAUTION

Read instructions carefully.

Read the instruction manual carefully before initiating the start-up and adjustment procedure. Verify that all of the equipment associated with and necessary to the safe operation of the system has been installed correctly, that all pre-commissioning checks have been carried out successfully and that all safety-related aspects of the installation are properly addressed.

Overview

SLATE Actuator provides multiple methods for actuator commissioning, precise closed-loop valve or damper position control, and health monitoring.

- Position can be commanded via Modbus using the SLATE Fuel Air Ratio Module.
- Commissioning is accomplished through the SLATE Fuel Air Ratio Module.

The normal and error codes are shown in Table 3.

Table 3. Alarm LED Codes.

LED code	Error Characteristic	Action
Continuous Blinking	Normal State – Ready to operate	None.
1	Out of range – Actuator is out of normal operating quadrant	Command actuator to normal operational range.
2	Not calibrated – Actuator not (Factory) calibrated	Factory calibration data lost; replace actuator.
3	Low Voltage	Check actuator input voltage.
4	High Temperature	Reduce ambient temperature; shield actuator from heat sources.
5	Mechanical binding, electrical shorts, or internal electronics fault.	Check all cables and electrical connections; check for debris or water on electronics; check for mechanical binding or slipping; if persistent, replace actuator.
5 or Dark Plus Continuous Reset	Lockout	Check power; replace actuator.

If the two shafts are not perfectly and concentrically aligned, additional binding and torque will be introduced into the assembly causing error codes to be sent from the SLATE actuator to the SLATE Fuel Air Ratio Module resulting in an inability to properly commission the system. If you are receiving actuator error codes either on the SLATE main module or in the error code register, check the mounting brackets and coupling's alignment and make necessary adjustments.

Alarm and lockout event reporting

SLATE alarm and lockout codes are accessed through the SLATE Fuel Air Ratio Module or using the SLATE touchscreen display. See documents 32-00013 and 32-00006 for more information.

The Low-Torque Actuators also display status messages through LED blinks. The LED is on the PCB inside the unit. These can be used for troubleshooting purposes.

The cover of the Low-Torque Actuators must be removed to see the two LEDs:

- Green LED: displays status, including alarm codes
- Yellow LED: displays communication activity (on RS-485, bus is working and actuator is communicating with SLATE system)



บริษัท เอดีดี เฟอร์เนส จำกัด

ADD FURNACE CO.,LTD.

44 ซอยบรมราชชนนี 70 ถนนบรมราชชนนี แขวงศาลาธรรมสพน์ เขตทวีวัฒนา กรุงเทพฯ 10170

โทร: 02-888-3472 โทร: ออตกเบบ:08-08-170-170 แฟกซ์: 02-888-3258

https://www.add-furnace.com E-mail: sales@add-furnace.com

SLATE™ LOW TORQUE ACTUATOR SERIES

Table 4 shows information about Lockout conditions.

Table 4. Lockout Conditions.

Lockout Code	Lockout Characteristic	Comments
1	RAM	Test of internal memory failed
2	RAM DMA	Test of internal memory failed
3	Flash Memory	Program corruption
4	Watchdog Startup	Internal watchdog unit failure
5	Safety Variables	Safety data corruption
6	Stack Overflow	Program execution error
7	System Tick	Program execution error
8	Main Loop	Program execution error
9	Processor Fault	Instruction test failure
10	Processor Fault – Memory	RAM/ROM failure

For More Information

The Honeywell Thermal Solutions family of products includes Honeywell Combustion Safety, Eclipse, Exothermics, Hauck, Kromschröder and Maxon. To learn more about our products, visit ThermalSolutions.honeywell.com or contact your Honeywell Sales Engineer.

Honeywell Process Solutions

Honeywell Thermal Solutions (HTS)
1250 West Sam Houston Parkway
South Houston, TX 77042
ThermalSolutions.honeywell

* U.S. Registered Trademark
© 2017 Honeywell International Inc.
32M-06009—05 M.S. Rev. 07-17
Printed in United States