



บริษัท เอดีดี เฟอร์เนส จำกัด

ADD FURNACE CO.,LTD.

44 ซอยบรมราชชนนี 70 ถนนบรมราชชนนี แขวงศาลาธรรมสพน์ เขตทวีวัฒนา กรุงเทพฯ 10170

โทร: 02-888-3472 โทร: ออกแบบ:08-08-170-170 แฟกซ์: 02-888-3258

<https://www.add-furnace.com> E-mail: sales@add-furnace.com

Honeywell

SLATE™

Fuel Air Ratio Module

R8001C6001

INSTALLATION INSTRUCTIONS





บริษัท เอดีดี เฟอร์เนส จำกัด

ADD FURNACE CO.,LTD.

44 ซอยบรมราชชนนี 70 ถนนบรมราชชนนี แขวงศาลาธรรมสพน์ เขตทวีวัฒนา กรุงเทพฯ 10170

โทร: 02-888-3472 โทร: ออกแบบ:08-08-170-170 แฟกซ์: 02-888-3258

<https://www.add-furnace.com> E-mail: sales@add-furnace.com



Scan for more information



Application

SLATE™ brings configurable safety and programmable logic together into one single platform. The platform can easily be customized for almost any requirement or application—offering virtually limitless development opportunities with far less complexity.

The R8001C6001 Fuel Air Ratio module uses the latest technology to control up to 4 SLATE actuators and/or 2 Variable Frequency Drives. The Fuel Air Ratio Control module controls the relationship between fuel, airflow and flue gas recirculation on a power burner.

Features

Within the SLATE system, the fuel air ratio module provides:

- Air-fuel ratio control for up to 4 actuators
- Drive 2 Variable Frequency Drives (VFDs)
- RS-485 Modbus communications to communicate to the actuators and receive feedback
- SLATE actuator torque sizes:
 - 50 in/lb (NEMA 1 and NEMA 4)
 - 150 in/lb (NEMA 1 and NEMA 4)
 - 300 in/lb (NEMA 4)
 - 900 in/lb (NEMA 4)
- Up to 24 points
- Field configurable
- Automated actuator endpoint seeking process
- UL Recognized and NFPA acceptable
- Password protected
- Fault information
- Status of four actuator channels
- Unused VFD terminals (Analog Cells) available for general purpose I/O configuration
- Flue Gas Recirculation (FGR)
- Trim
- Dual Fuel



บริษัท เอดีดี เฟอร์เนส จำกัด

ADD FURNACE CO.,LTD.

44 ซอยบรมราชชนนี 70 ถนนบรมราชชนนี แขวงศาลาธรรมสพน์ เขตทวีวัฒนา กรุงเทพฯ 10170

โทร: 02-888-3472 โทร: ออกแบบ:08-08-170-170 แฟกซ์: 02-888-3258

<https://www.add-furnace.com> E-mail: sales@add-furnace.com

Safety Features

- Class C operating software system
- Fail-safe feedback
- Curve verification algorithms
- Password protected
- Built in self test
- No slope constraints that would limit the steepness of the curve
- Component anti-swap protection
- Off curve checking algorithm

Specifications

Electrical Ratings

Voltage and Frequency: See Tables 1–5.

Environmental Ratings:

Ambient Temperature:

Operating: -20°F to +150°F (-29°C to +66°C).

Shipping: -40°F to +150°F (-40°C to +66°C).

Humidity: 95% continuous, noncondensing.

Vibration: 0.5G environment

Dimensions: See Fig. 1.

Weight: 13.6 oz (0.39 Kg)

Approvals

Underwriters Laboratories Inc. Listed, File: MP268

Factory Mutual

IRI Acceptable

Federal Communications Commission: Part 15, Class A

Must be mounted inside a grounded metal enclosure.

Mounting: DIN Rail (See Fig. 2)

Required Components

R8001A1001 SLATE Base Module

R8001S9001 Sub-Base Module



บริษัท เอดีดี เฟอร์เนส จำกัด

ADD FURNACE CO.,LTD.

44 ซอยบรมราชชนนี 70 ถนนบรมราชชนนี แขวงศาลาธรรมสพน์ เขตทวีวัฒนา กรุงเทพฯ 10170

โทร: 02-888-3472 โทร: ออกแบบ:08-08-170-170 แฟกซ์: 02-888-3258

<https://www.add-furnace.com> E-mail: sales@add-furnace.com

R8001B2001 SLATE Burner Control Module

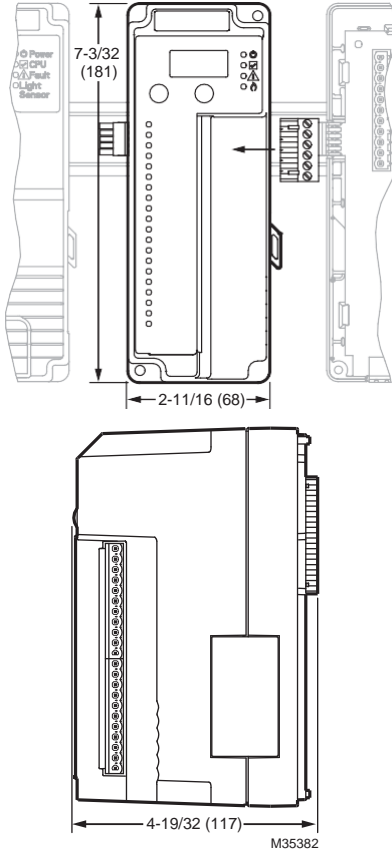

Fig. 1. Dimensions in in. (mm).

Principal Technical Features

The R8001C6001 fuel air ratio module monitors and controls the air-fuel ratio for combustion applications.



LED Array

There are three LEDs on the front of the Fuel Air Ratio module that provide quick identification of the system status and any problems that might occur. The status is broadcast to other modules on the platform bus in case they are affected by the inoperable modules. See Table 1 for descriptions.

LED	Color	Description
Power	No light	System does not have power
	Green	System has power
CPU	Red	No valid configuration
	Green	Running
Fault	Red	Fault
	No light	No fault

Table 1. LED Descriptions.

LED Displays

The SLATE system modules have three-character LED displays used for indicating the module number of the SLATE system. They also have three-position LED colors to indicate terminal states as shown in Table 2.

Color	Description
Green	Terminal is ON or is Normal
Red	Fault
No light	Terminal is OFF or Not in use

Table 2. Terminal LED Meanings.



บริษัท เอดีดี เฟอร์เนส จำกัด

ADD FURNACE CO.,LTD.

44 ซอยบรมราชชนนี 70 ถนนบรมราชชนนี แขวงศาลาธรรมสพน์ เขตทวีวัฒนา กรุงเทพฯ 10170

โทร: 02-888-3472 โทร: ออกแบบ:08-08-170-170 แฟกซ์: 02-888-3258

<https://www.add-furnace.com> E-mail: sales@add-furnace.com

Select and Reset Buttons

The SLATE system modules have Select and Reset buttons located on the front of the module and beneath the segment display. The Reset button is used to clear a lockout and reset the module. The Select button is used to scroll through the segment display information.

Installation

WARNING

Fire or Explosion Hazard

Can cause severe injury, death, or property damage.

Verification of safety requirements must be performed each time a control is installed on a burner to prevent possible hazardous burner operation.

When Installing This Product

1. Read these instructions carefully. Failure to follow them could damage the product or cause a hazardous condition.
2. Check the ratings given in the instructions and on the product to make sure the product is suitable for your application.
3. After installation is complete, check out the product operation as provided in these instructions.
4. The SLATE module must be mounted in an electrical enclosure with adequate clearance for servicing, installation and removal of modules.



บริษัท เอดีดี เฟอร์เนส จำกัด

ADD FURNACE CO.,LTD.

44 ซอยบรมราชชนนี 70 ถนนบรมราชชนนี แขวงศาลาธรรมสพน์ เขตทวีวัฒนา กรุงเทพฯ 10170

โทร: 02-888-3472 โทร: ออกแบบ:08-08-170-170 แฟกซ์: 02-888-3258

<https://www.add-furnace.com> E-mail: sales@add-furnace.com

Wiring

WARNING

Electrical Shock Hazard.

Can cause severe injury, death or equipment damage.

1. Disconnect the power supply before beginning installation to prevent electrical shock and equipment damage. More than one power supply disconnect can be involved.

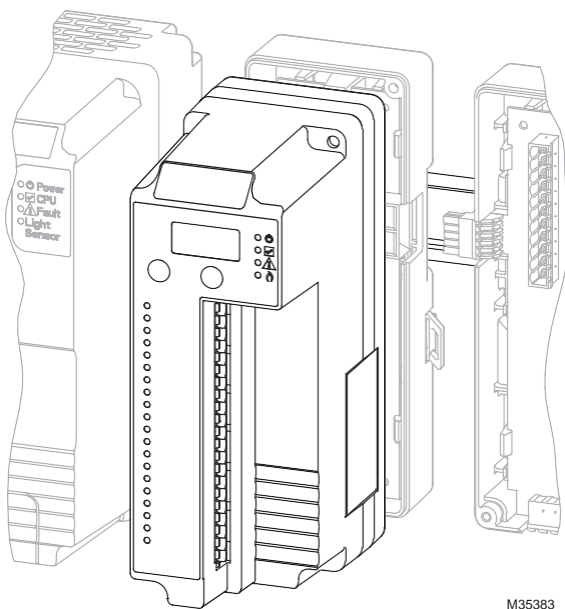

Fig. 2. Installing the Fuel Air Ratio Module on the Sub-Base Module.

2. Wiring must comply with all applicable codes, ordinances and regulations.
3. Wiring must comply with NEC Class 1 (Line Voltage) wiring.



บริษัท เอดีดี เฟอร์เนส จำกัด

ADD FURNACE CO.,LTD.

44 ซอยบรมราชชนนี 70 ถนนบรมราชชนนี แขวงศาลาธรรมสพน์ เขตทวีวัฒนา กรุงเทพฯ 10170

โทร: 02-888-3472 โทร: ออกแบบ:08-08-170-170 แฟกซ์: 02-888-3258

<https://www.add-furnace.com> E-mail: sales@add-furnace.com

IMPORTANT

- 1. This equipment generates, uses and can radiate radio frequency energy and, if not installed and used in accordance with these instructions, may cause interference for radio communications. It has been tested and found to comply with the limits of a Class A computing device of part 15 of FCC rules, which are designed to provide reasonable protection against such interference when operated in a commercial environment. Operation of this equipment in a residential area may cause interference; in which case, the user, at their own expense, may be required to take whatever measures are required to correct this interference.*
- 2. This digital apparatus does not exceed the Class A limits for radio noise, set out in the Radio Interference Regulations of the Canadian Department of Communications.*
- 3. Cable shield must be terminated to ground at both ends. If shielded cable is NOT used, use three-wire twisted cable.*



WARNING

Fire or Explosion Hazard

Can cause severe injury, death, or property damage.

Disconnect the power supply from the main disconnect before beginning installation to prevent electrical shock and equipment damage. More than one disconnect can be required.

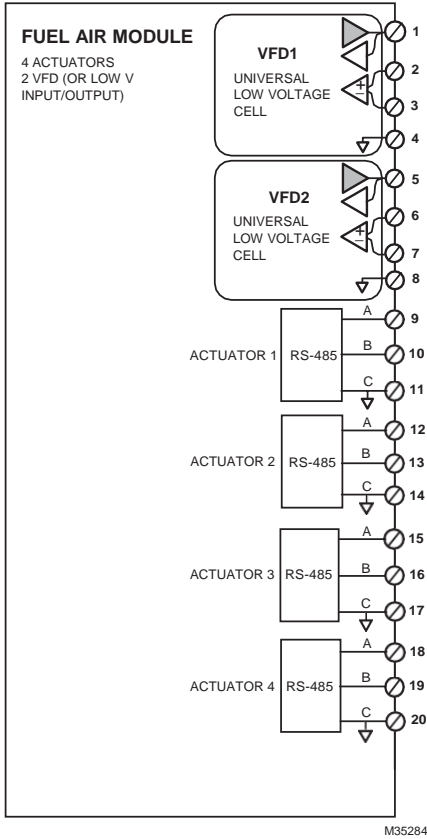

Fig. 3. Wiring diagram for Fuel Air Ratio Module.



บริษัท เอดีดี เฟอร์เนส จำกัด

ADD FURNACE CO.,LTD.

44 ซอยบรมราชชนนี 70 ถนนบรมราชชนนี แขวงศาลาธรรมสพน์ เขตทวีวัฒนา กรุงเทพฯ 10170

โทร: 02-888-3472 โทร: ออกแบบ:08-08-170-170 แฟกซ์: 02-888-3258

<https://www.add-furnace.com> E-mail: sales@add-furnace.com

Terminal	Description	Rating
1	VFD1 - Cell A (T1)	See Tables 2-5 for configuration options
2	VFD1 - Cell A (T2)	See Tables 2-5 for configuration options
3	VFD1 - Cell A (T3)	See Tables 2-5 for configuration options
4	VFD1 - Cell A (T4)	See Tables 2-5 for configuration options
5	VFD2 - Cell B (T1)	See Tables 2-5 for configuration options
6	VFD2 - Cell B (T2)	See Tables 2-5 for configuration options
7	VFD2 - Cell B (T3)	See Tables 2-5 for configuration options
8	VFD2 - Cell B (T4)	See Tables 2-5 for configuration options
9	A1 - A (RS485)	---
10	A1 - B (RS485)	---
11	A1 - C (GND)	---
12	A2 - A (RS485)	---
13	A2 - B (RS485)	---
14	A2 - C (GND)	---
15	A3 - A (RS485)	---
16	A3 - B (RS485)	---
17	A3 - C (GND)	---
18	A4 - A (RS485)	---
19	A4 - B (RS485)	---
20	A4 - C (GND)	---
21	Unused	---
22	Unused	---

Table 3. Terminal Ratings.



Terminal Functions				Min	Typical	Max	Units	
T1	Voltage	In	Range	0.0	-	15.0	VDC	Rin=1MOhm
			Resolution	-	2.43	-	mV DC	
			Null	-25.0	-	25.0	mV DC	
			Accuracy	-25.0	-	25.0	mV DC	Whichever is greater
			-1.0	-	1.0	%		
		Out ^c	Range	0.0	-	15.0	VDC	10KOhm load
			Resolution	-	4.0	-	mV DC	
			Null	100.0	-	100.0	mV DC	
	Accuracy		-50.0	-	50.0	mV DC	Whichever is greater	
		-1.5	-	1.5	%			
	Current	In	Range	0.0	-	25.0	mA DC	^a
			Resolution	-	7.4	-	uA DC	
			Null	-0.5	-	0.5	mA DC	
			Accuracy	-1.5	-	1.5	%	
		Out ^{b,c}	Range	0.0	-	25.0	mA DC	Max Load = 500 Ω
			Resolution	-	4.0	-	mA Ω	
Null			-0.5	-	0.5	mA DC		
Accuracy			-300.0	-	300.0	uA DC	0 to 25 mA	
	-50	-	50	uA DC	4 to 20 mA			
T2	Voltage	In	Amplitude	0.0	-	15.0	VDC	
			Trip Point	-	3.0	-	VDC	Comparator Only
			Hysteresis	-	0.25	-	VDC	
			Resolution	-	0.37	-	mV DC	
			Null	-25.0	-	25.0	mV DC	
			Accuracy	-25.0	-	25.0	mV DC	
T3	Voltage	In	Range	0.0	-	15.0	VDC	
			Resolution	-	0.37	-	mV DC	
			Null	-25.0	-	25.0	mV DC	
			Accuracy	-25.0	-	25.0	mV DC	
	Current	In	Range	0.2	-	25.0	mA DC	
			Resolution	-	3.7	-	uA DC	
			Null	-0.5	-	0.5	mA DC	
			Accuracy	-1.5	-	1.5	%	0 to 25 mA

^aT1 input terminal is held at constant 2.5VDC over allowable current range.

^bAccuracy specification given is for 100 Ω load. Resolution specification can be converted to mA by dividing out load.

^cI_{max}=25mA for V_{out}<10V

I_{max}=20mA for 10V<V_{out}<15V

Table 4. Specifications for Basic Cell Functions.



Specifications based on worst case over ambient temperatures.

Complex Functions		Min	Typical	Max	Units		
Thermocouple							
T2 & T3	Type J	Range	-200.0		1025.0	°C	
		Resolution	-	0.1	-	°C	
		Accuracy	-5.0	-	5.0	°C	
	Type K	Range	-150.0	-	1000.0	°C	
		Resolution	-	0.1	-	°C	
		Accuracy	-5.0	-	5.0	°C	
RTD							
T2 & T3 & T4	Type PT100 ^a	Range	-135.0	-	250.0	°C	3 wire, 100 Ω
		Resolution	-	0.5	-	°C	
		Accuracy	-2.0	-	2.0	°C	
	Type PT1000	Range	-135.0	-	250.0	°C	3 wire, 1000 Ω
		Resolution		0.5		°C	
		Accuracy	-2.0	-	2.0	°C	
NTC							
T1-T3, T1-T4	Type 10K	Range	-40.0 ^b	-	175.0	°C	T4 rated to 0 °C
		Resolution	-	0.1	-	°C	
		Accuracy ^c	-2.0	-	2.0	°C	-40 °C to 25 °C
			-1.0	-	1.0	°C	25 °C to 125 °C
			-1.5	-	1.5	%	
			-3.0	-	3.0	°C	125 °C to 175 °C
T1-T3, T1-T4	Type 12K	Range	-20.0	-	125.0	°C	T4 rated to 0 °C
		Resolution	-	0.1	-	°C	
		Accuracy ^c	-2.0	-	2.0	°C	-20 °C to 30 °C
			-1.0	-	1.0	°C	30 °C to 120 °C
			-1.5	-	1.5	%	
			-3.0	-	3.0	°C	120 °C to 125 °C
T1-T3, T1-T4	Type 20K	Range	-25.0	-	150.0	°C	T4 rated to 0 °C
		Resolution	-	0.1	-	°C	
		Accuracy ^c	-2.0	-	2.0	°C	-25 °C to 50 °C
			-1.0	-	1.0	°C	50 °C to 135 °C
			-1.5	-	1.5	%	
			-3.0	-	3.0	°C	135 °C to 150 °C

^a Shielded cable required for reliable operation in noisy environment.

^b NTC on terminal T4 is rated down to 0 °C.

^c Temperatures refer to sense range.

Table 5. Specifications Cell Complex Functions.



	Frequency / PWM Functions	Min	Typical	Max	Units		
PWM Out							
T1	Amplitude	5.0	-	10.0	VDC	Low output state = 0V	
	Frequency	100.0	-	1000.0	Hz		
	Duty Cycle	2.0	-	98.0	%DC	0-100% output allowed	
	Resolution	-	1.0	-	%		
	Accuracy	-0.5	-	0.5	%DC	10V amplitude	
Frequency In							
T2-T4	Amplitude	5.0	10.0	15.0	VDC		
	Range	2.0	-	1000.0	Hz		
	Min. "on" pulse width (low %DC)	-	50.0	-	usec	10V amplitude	
	Min. "off" pulse width (high %DC)	-	130.0	-	usec	10V amplitude	
	Duty Cycle	2 – 100 Hz	2.0	-	98.0	%DC	10V amplitude
		1000 Hz	5.0	-	85.0	%DC	10V amplitude
	Resolution	-	1.0	-	Hz		
	Accuracy	-5.0	-	0.0	%	Whichever is greater	
-1.0		-	0.0	Hz			
PWM In							
T2-T4	Amplitude ^a	5.0	10.0	15.0	VDC		
	Frequency	125.0	-	500.0	Hz		
	Min. "on" pulse width (low %DC)	-	50.0	-	usec	10V amplitude	
	Min. "off" pulse width (high %DC)	-	130.0	-	usec	10V amplitude	
	Duty Cycle	125 – 500 Hz	5.0	-	90.0	%DC	10V amplitude
	Resolution		-	1.0	%DC		
	Accuracy	125 Hz	-1.5	-	1.5	%DC	10V amplitude
500 Hz		-7.5	-	7.5	%DC	10V amplitude	

^a Trip points = 3.0V +/- 0.25V

Hysteresis Voltage = 0.5V

Table 6. Specifications for Cell Frequency Functions.



Configuration	Min	Optimum Range for Performance	Max	
Thermocouple	J	-50°C	1025°C	± 4 °C
	K	-50°C	1000°C	± 4 °C
RTD	-135°C		250°C	± 2 °C
NTC	25°C		125°C	± 1°C
Current Out	4 mA		20 mA	± .05 mA
Voltage: In / Out	2 V		10 V	0.3 %, typical

Table 7. Suggested Sensor Selection Based on Application.

Application	Recommended Wire Size	Recommended Part Numbers
Communication Lines	22 AWG two-wire twisted pair with ground, or five-wire.	Belden 8723 shielded cable or equivalent.
Other terminals	18 AWG wire insulated for voltages and temperatures for given application.	TTW60C, THW75C, THHN90C

Table 8. Recommended Wire Sizes and Part Numbers.

Resistance to Temperature Conversion Tables

Below are the lookup tables for various types of SLATE sensors. Linear interpolation is used for values that are between the points that are shown.

10K NTC

Ohms	Degrees C
100.000	228.199
120.000	214.979
144.000	202.439
172.800	190.526
207.360	179.195
248.832	168.404



บริษัท เอดีดี เฟอร์เนส จำกัด

ADD FURNACE CO.,LTD.

44 ซอยบรมราชชนนี 70 ถนนบรมราชชนนี แขวงศาลาธรรมสพน์ เขตทวีวัฒนา กรุงเทพฯ 10170

โทร: 02-888-3472 โทร: ออกแบบ:08-08-170-170 แฟกซ์: 02-888-3258

<https://www.add-furnace.com> E-mail: sales@add-furnace.com

298.598	158.116
358.318	148.295
429.982	138.912
619.174	121.345
891.610	105.213
1283.918	90.347
1848.843	76.605
2662.333	63.862
3833.760	52.015
5520.614	40.972
7949.685	30.653
11447.546	20.990
19781.359	7.594
34182.189	-4.636
59066.823	-15.846
102067.470	-26.159
176372.588	-35.678
304771.832	-44.491

12K NTC

Ohms	Degrees C
494.600	124.750
560.400	119.750
726.000	109.750
952.300	99.750
1266.000	89.750
1707.000	79.750
2337.000	69.750
3252.000	59.750
4607.000	49.750



บริษัท เอดีดี เฟอร์เนส จำกัด

ADD FURNACE CO.,LTD.

44 ซอยบรมราชชนนี 70 ถนนบรมราชชนนี แขวงศาลาธรรมสพน์ เขตทวีวัฒนา กรุงเทพฯ 10170

โทร: 02-888-3472 โทร: ออกแบบ:08-08-170-170 แฟกซ์: 02-888-3258

<https://www.add-fumace.com> E-mail: sales@add-fumace.com

6652.000	39.750
9804.000	29.750
12000.000	24.750
14770.000	19.750
22800.000	9.750
36130.000	-0.250
58880.000	-10.250
98970.000	-20.250

20K NTC

Ohms	Degrees C
372.200	150.000
555.080	133.250
842.660	117.050
1301.180	101.450
2047.500	86.400
3284.380	71.900
5378.420	57.850
8996.680	44.250
15345.520	31.150
26744.880	18.500
47748.920	6.250
87148.340	-5.550
163394.900	-17.000
260844.260	-25.000



บริษัท เอดีดี เฟอร์เนส จำกัด

ADD FURNACE CO.,LTD.

44 ซอยบรมราชชนนี 70 ถนนบรมราชชนนี แขวงศาลาธรรมสพน์ เขตทวีวัฒนา กรุงเทพฯ 10170

โทร: 02-888-3472 โทร: ออกแบบ:08-08-170-170 แฟกซ์: 02-888-3258

<https://www.add-furnace.com> E-mail: sales@add-furnace.com

100 ohm RTD

Ohms	Degrees C
18.526	-200.250
50.064	-125.250
88.223	-30.250
132.801	84.750
174.010	194.750
213.822	304.750
250.520	409.750
280.962	499.750

1000 ohm RTD

Ohms	Degrees C
185.26	-200.250
500.64	-125.250
882.23	-30.250
1328.01	84.750
1740.10	194.750
2138.22	304.750
2505.20	409.750
2809.62	499.750

1000 ohm Balco RTD

Ohms	Degrees C
779.000	-40.000
864.700	-15.000
956.900	10.000
1044.400	32.200
1148.900	57.200
1247.300	79.400
1350.900	101.700
1418.200	115.600



บริษัท เอดีดี เฟอร์เนส จำกัด

ADD FURNACE CO.,LTD.

44 ซอยบรมราชชนนี 70 ถนนบรมราชชนนี แขวงศาลาธรรมสพน์ เขตทวีวัฒนา กรุงเทพฯ 10170

โทร: 02-888-3472 โทร: ออกแบบ:08-08-170-170 แฟกซ์: 02-888-3258

<https://www.add-fumace.com> E-mail: sales@add-fumace.com

Type J thermocouple

microVolts	Degrees C
-8000.000	-205.214
-7600.000	-187.611
-7100.000	-169.194
-6300.000	-144.092
-5200.000	-114.127
-3800.000	-80.349
-1900.000	-38.715
-700.000	13.754
4600.000	87.675
12600.000	232.778
28400.000	517.923
33600.000	608.497
38300.000	686.565
44300.000	781.520
51600.000	895.549
56800.000	980.638
59500.000	1026.230

Type K thermocouple

microVolts	Degrees C
-5000.000	-153.736
-4400.000	-129.609
-3600.000	-101.517
-2600.000	-70.403
-1200.000	-31.171
-700.000	17.529
6500.000	159.027
11300.000	278.023
17500.000	426.066
29000.000	696.902
34500.000	829.998
39500.000	954.713
41600.000	1008.307



Type T thermocouple

microVolts	Degrees C
-5000.000	-166.012
-4200.000	-130.434
-3100.000	-89.867
-1600.000	-43.103
500.000	13.280
3100.000	74.769
6500.000	146.427
10900.000	230.361
16500.000	328.408
20800.000	399.315

Recommended Grounding Practices

Use an Earth ground or a signal ground as described below.

Earth ground (Base, Rectification Flame Amp Module, other modules optional)

1. Use to provide a connection between the base and the control panel of the equipment. Earth ground must be capable of conducting enough current to blow the breaker in the event of an internal short circuit.
2. Use wide straps or brackets to provide minimum length, maximum surface area ground conductors. If a leadwire is required, use 14 AWG copper wire.
3. Make sure that mechanically tightened joints along the ground path are free of nonconductive coatings and protected against corrosion on mating surfaces.

Signal ground

Note the 18V system ground is not electrically connected to earth ground. Follow local codes and appliance recommendations to determine if this should be connected to earth ground.



บริษัท เอดีดี เฟอร์เนส จำกัด

ADD FURNACE CO.,LTD.

44 ซอยบรมราชชนนี 70 ถนนบรมราชชนนี แขวงศาลาธรรมสพน์ เขตทวีวัฒนา กรุงเทพฯ 10170

โทร: 02-888-3472 โทร: ออกแบบ:08-08-170-170 แฟกซ์: 02-888-3258

<https://www.add-fumace.com> E-mail: sales@add-fumace.com

Recommended wire routing of leadwires

Do not run high voltage ignition transformer wires in the same conduit with the flame detector or data lines.

Be sure loads do not exceed the terminal ratings. Refer to the labels or terminal ratings in Table 3.

The SLATE system must be mounted in an electrical enclosure. When mounting in an electrical enclosure, provide adequate clearance for servicing, installation and removal of SLATE modules.

Maximum wire length:

- The maximum leadwire length is 300 feet to terminal inputs (Control, Running/Lockout Interlock)
- For Remote Bus data lines, maximum cable length depends on the number of modules connected, the noise conditions and the cable used. The maximum of all interconnecting wires is 4000 feet.



บริษัท เอดีดี เฟอร์เนส จำกัด

ADD FURNACE CO.,LTD.

44 ซอยบรมราชชนนี 70 ถนนบรมราชชนนี แขวงศาลาธรรมสพน์ เขตทวีวัฒนา กรุงเทพฯ 10170

โทร: 02-888-3472 โทร: ออกแบบ:08-08-170-170 แฟกซ์: 02-888-3258

<https://www.add-fumace.com> E-mail: sales@add-furnace.com



32-00006-03

For more information and detailed instructions on the R8001C6001 and the entire SLATE system please refer to the SLATE User Guide located on our website at <http://combustion.honeywell.com/SLATE>

Honeywell

Automation and Control Solutions

Honeywell International Inc.
1985 Douglas Drive North
Golden Valley, MN 55422
customer.honeywell.com

® U.S. Registered Trademark.
© 2015 Honeywell International Inc.
32-00006—03 M.S. Rev. 05-15
Printed in U.S.A.