



บริษัท เอดีดี เฟอร์เนส จำกัด

ADD FURNACE CO.,LTD.

44 ซอยบรมราชชนนี 70 ถนนบรมราชชนนี แขวงศาลาธรรมสพน์ เขตทวีวัฒนา กรุงเทพฯ 10170

โทร: 02-888-3472 โทร: ออกแบบ:08-08-170-170 แฟกซ์: 02-888-3258

<https://www.add-furnace.com> E-mail: sales@add-furnace.com

Honeywell

SLATE™

Limit Control Module

R8001L8001

INSTALLATION INSTRUCTIONS





บริษัท เอดีดี เฟอร์เนส จำกัด

ADD FURNACE CO.,LTD.

44 ซอยบรมราชชนนี 70 ถนนบรมราชชนนี แขวงศาลาธรรมสพน์ เขตทวีวัฒนา กรุงเทพฯ 10170

โทร: 02-888-3472 โทร: ออกแบบ:08-08-170-170 แฟกซ์: 02-888-3258

<https://www.add-furnace.com> E-mail: sales@add-furnace.com



Scan for more information



Application

SLATE™ brings configurable safety and programmable logic together into one single platform. The platform can easily be customized for almost any requirement or application—offering virtually limitless development opportunities with far less complexity.

The R8001L8001 SLATE Limit Control Module is part of the SLATE Combustions System. The SLATE Limit Control Module provides the ability to bring in any type of analog signal and create limits on either pressure or temperature without needing a UDC Controller.

Features

- 12 limit blocks with each block monitoring any sensor or pair of sensors
- One limit module for multiple burner controls
- 4 sensors available for Limit Block use (2 sets of redundant safety inputs)
- Unused Analog Cells available for general purpose I/O configuration
- Redundant limit relay output

Specifications

Electrical Ratings:

See Table 3–Table 7.

Environmental Ratings

Ambient Temperature:

Operating: -20°F to +150°F (-29°C to +66°C).

Shipping: -40°F to +150°F (-40°C to +66°C).

Humidity: 95% continuous, noncondensing.

Vibration: 0.5G environment

Dimensions: See Fig. 1

Weight: 2 lb 1 oz (0.94 Kg)



Approvals

Underwriters Laboratories Inc. Listed, File: MP268

IRI Acceptable

Federal Communications Commission: Part 15, Class A

Must be mounted inside a grounded metal enclosure.

Mounting

DIN Rail (See Fig. 2)

Required Components

R8001A1001 SLATE Base Controller

R8001S9001 SLATE Sub-Base Module

R8001B2001 SLATE Burner Control Module

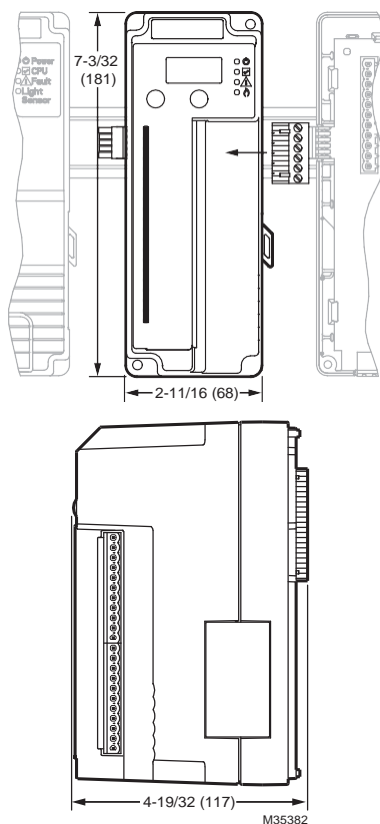

Fig. 1. Dimensions in in. (mm).



LED Array

There are four LEDs on the front of the Limit Control Module that provides quick identification of the system status and any problems that might occur. The status is broadcast to other modules on the platform bus in case they are affected by the inoperable modules.

The LEDs on the module are for the sensors, the inputs and outputs, and for the Reference V.

Terminals 18 and 19 are the limit contacts.

Terminals 20 and 22 are reference voltage terminals to indicate to the Limit Module what reference voltage it's operating at.



LED	Color	Description
 Power	No light	System does not have power
	Green	System has power
 CPU	Red	No wire sheet or problem with the wire sheet
	Green	Running
 Fault	Red	Fault
	No light	Running

Table 1. LED Descriptions.

LED Display

The SLATE system modules have a seven-segment, three-position LED display used for indicating the module number of the SLATE system. The LED colors indicate the terminal state as shown in Table 2.

Color	Description
Green	Terminal is on
Red	Fault
No light	Not in use

Table 2. Terminal LED Meanings.



Select and Reset Buttons

The SLATE system modules have a Select and Reset buttons located on the front of the module and beneath the segment display. The Reset button is used to clear a lockout and reset the module. The Select button is used to scroll through the segment display information.

Installation



WARNING

Fire or Explosion Hazard

Can cause severe injury, death, or property damage.

Verification of safety requirements must be performed each time a control is installed on a burner to prevent possible hazardous burner operation.

When Installing This Product

1. Read these instructions carefully. Failure to follow them could damage the product or cause a hazardous condition.
2. Check the ratings given in the instructions and on the product to make sure the product is suitable for your application.
3. After installation is complete, check out the product operation as provided in these instructions.
4. The SLATE module must be mounted in an electrical enclosure with adequate clearance for servicing, installation and removal of modules.



WARNING

Electrical Shock Hazard.

Can cause severe injury, death or equipment damage.

1. Disconnect the power supply before beginning installation to prevent electrical shock and equipment damage. More than one power supply disconnect can be involved.

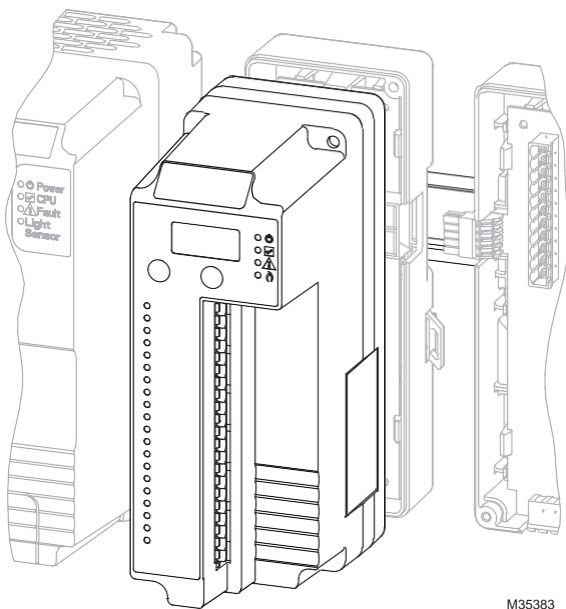

Fig. 2. Installing the Limit Control Module on the Sub-Base Module.

2. Wiring must comply with all applicable codes, ordinances and regulations.
3. Wiring must comply with NEC Class 1 (Line Voltage) wiring.



IMPORTANT

- 1. This equipment generates, uses and can radiate radio frequency energy and, if not installed and used in accordance with these instructions, may cause interference for radio communications. It has been tested and found to comply with the limits of a Class A computing device of part 15 of FCC rules, which are designed to provide reasonable protection against such interference when operated in a commercial environment. Operation of this equipment in a residential area may cause interference; in which case, the user, at their own expense, may be required to take whatever measures are required to correct this interference.*
- 2. This digital apparatus does not exceed the Class A limits for radio noise, set out in the Radio Interference Regulations of the Canadian Department of Communications.*
- 3. For combination gas-oil burner applications, a double pole, double throw (dpdt) fuel select switch is required.*
- 4. Cable shield must be terminated to ground at both ends. If shielded cable is NOT used, use three-wire twisted cable.*

Wiring



WARNING

Electrical Shock Hazard.

Can cause severe injury, death, or equipment damage.

Disconnect the power supply from the main disconnect before beginning installation to prevent electrical shock and equipment damage. More than one disconnect can be required.

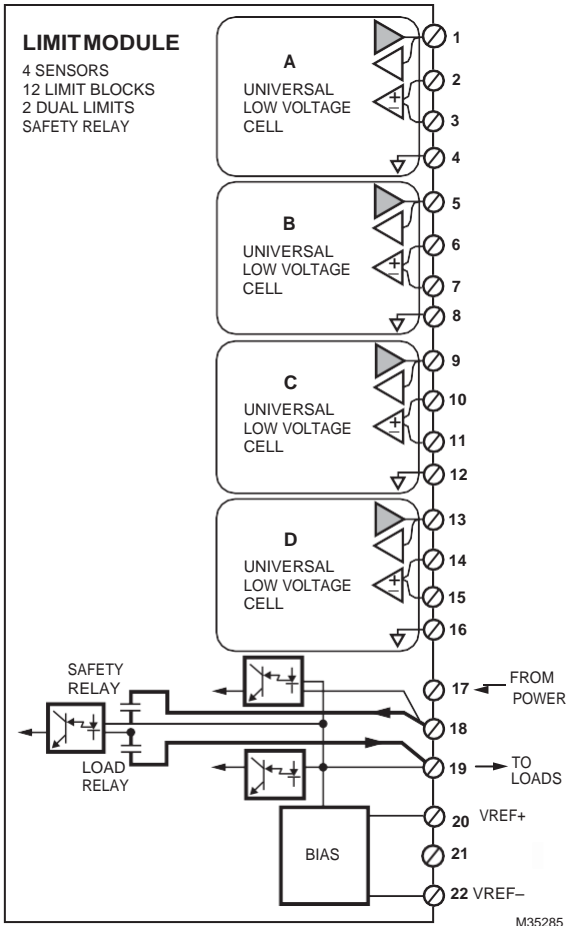

Fig. 3. Wiring diagram for Limit Control Module.



Terminal	Description	Rating
1	Cell A (T1)	See Table 4–7 for configuration options
2	Cell A (T2)	See Table 4–7 for configuration options
3	Cell A (T3)	See Table 4–7 for configuration options
4	Cell A (T4)	See Table 4–7 for configuration options
5	Cell B (T5)	See Table 4–7 for configuration options
6	Cell B (T6)	See Table 4–7 for configuration options
7	Cell B (T7)	See Table 4–7 for configuration options
8	Cell B (T8)	See Table 4–7 for configuration options
9	Cell C (T9)	See Table 4–7 for configuration options
10	Cell C (T10)	See Table 4–7 for configuration options
11	Cell C (T11)	See Table 4–7 for configuration options
12	Cell C (T12)	See Table 4–7 for configuration options
13	Cell D (T13)	See Table 4–7 for configuration options
14	Cell D (T14)	See Table 4–7 for configuration options
15	Cell D (T15)	See Table 4–7 for configuration options
16	Cell D (T16)	See Table 4–7 for configuration options
17	Unused	---
18	Safety Relay (dry contacts)	9.8 FLA, 58.8 LRA @ 120VAC, 4A (0.5 PF), 20A inrush @ 240VAC, 2A cont, 10A inrush @ 24VDC
19	Safety Relay (dry contacts)	(see Terminal 18 above)
20	Vref+	24VDC (0.1mA), 24VAC (0.1mA), 85-264VAC (0.2mA)
21	Unused	---
22	Vref-	(see Terminal 20 above)

Table 3. Terminal Ratings.

Note: only one configuration option per cell is allowed for cells configured as a Limit Block.



Basic Functions			Min	Typical	Max	Units		
T1	Voltage	In	Range	0.0	-	15.0	VDC	
			Resolution	-	2.43	-	mV DC	
			Null	-25.0	-	25.0	mV DC	
			Accuracy	-25.0	-	25.0	mV DC	Whichever is greater
			-1.0	-	1.0	%		
		Out	Range	0.0	-	15.0	VDC	
	Resolution		-	4.0	-	mV DC		
	Null		100.0	-	100.0	mV DC		
	Accuracy		-50.0	-	50.0	mV DC	Whichever is greater	
		-1.5	-	1.5	%			
	Current	In	Range	0.0	-	25.0	mA DC	a
			Resolution	-	7.4	-	uA DC	
Null			-0.5	-	0.5	mA DC		
Accuracy			-1.5	-	1.5	%	0 to 25 mA	
Out ^b		Range	0.0	-	25.0	mA DC	Max Load = 500 Ω	
		Resolution	-	4.0	-	mA Ω		
		Null	-0.5	-	0.5	mA DC		
		Accuracy	-300.0	-	300.0	uA DC		0 to 25 mA
		-50.0	-	50.0	uA DC	4 to 20 mA		
T2	Voltage	In	Amplitude	0.0	-	15.0	VDC	
			Trip Point	-	3.0	-	VDC	Comparator Only
			Hysteresis	-	0.25	-	VDC	
			Resolution	-	0.37	-	mV DC	
			Null	-25.0	-	25.0	mV DC	
			Accuracy	-25.0	-	25.0	mV DC	
T3	Voltage	In	Range	0.0	-	15.0	VDC	
			Resolution	-	0.37	-	mV DC	
			Null	-25.0	-	25.0	mV DC	
			Accuracy	-25.0	-	25.0	mV DC	
	Current	In	Range	0.2	-	25.0	mA DC	
			Resolution	-	3.7	-	uA DC	
			Null	-0.5	-	0.5	mA DC	
		Accuracy	-1.5	-	1.5	%	0 to 25 mA	

^a T1 input terminal is held at constant 2.5VDC over allowable current range.

^b Accuracy specification given is for 100 Ω load. Resolution specification can be converted to mA by dividing out load.

Table 4. Specifications for Basic Cell Functions.

Specifications based on worst case over ambient temperatures.



Complex Functions		Min	Typical	Max	Units		
Thermocouple							
T2 & T3	Type J	Range	-200.0		1025.0	°C	
		Resolution	-	0.1	-	°C	
		Accuracy	-5.0	-	5.0	°C	
	Type K	Range	-150.0	-	1000.0	°C	
		Resolution	-	0.1	-	°C	
		Accuracy	-5.0	-	5.0	°C	
RTD							
T3 & T4	Type PT100 ^a	Range	-135.0	-	250.0	°C	3 wire, 100 Ω
		Resolution	-	0.5	-	°C	
		Accuracy	-2.0	-	2.0	°C	
	Type PT1000	Range	-135.0	-	250.0	°C	3 wire, 1000 Ω
		Resolution		0.5		°C	
		Accuracy	-2.0	-	2.0	°C	
NTC							
T3 & T4	Type 10K	Range	-40.0 ^b	-	175.0	°C	T4 rated to 0 °C
		Resolution	-	0.1	-	°C	
		Accuracy ^c	-2.0	-	2.0	°C	-40 °C to 25 °C
			-1.0	-	1.0	°C	
			-1.5	-	1.5	%	25 °C to 125 °C
			-3.0	-	3.0	°C	

^a Shielded cable required for reliable operation in noisy environment.

^b NTC on terminal T4 is rated down to 0 °C.

^c Temperatures refer to sense range.

Table 5. Specifications Cell Complex Functions.



	Frequency / PWM Functions	Min	Typical	Max	Units		
PWM Out							
T1	Amplitude	5.0	-	10.0	VDC	Low output state = 0V	
	Frequency	100.0	-	1000.0	Hz		
	Duty Cycle	2.0	-	98.0	%DC	Allowable output %DC	
	Resolution	-	1.0	-	%		
	Accuracy	-0.5	-	0.5	%DC	10V amplitude	
Frequency In							
T2	Amplitude	5.0	10.0	15.0	VDC		
	Range	2.0	-	1000.0	Hz		
	Min. "on" pulse width (low %DC)	-	50.0	-	usec	10V amplitude	
	Min. "off" pulse width (high %DC)	-	130.0	-	usec	10V amplitude	
	Duty Cycle	2 – 100 Hz	2.0	-	98.0	%DC	10V amplitude
		1000 Hz	5.0	-	85.0	%DC	10V amplitude
	Resolution	-	1.0	-	Hz		
	Accuracy		-5.0	-	0.0	%	Whichever is greater
		-1.0	-	0.0	Hz		
PWM In							
T2	Amplitude	5.0	10.0	15.0	VDC		
	Frequency	125.0	-	500.0	Hz		
	Min. "on" pulse width (low %DC)	-	50	-	usec	10V amplitude	
	Min. "off" pulse width (high %DC)	-	130	-	usec	10V amplitude	
	Duty Cycle	125 – 500 Hz	5.0	-	90.0	%DC	10V amplitude
	Resolution		-	1.0	%DC		
	Accuracy	125 Hz	-1.5	-	1.5	%DC	10V amplitude
		500 Hz	-7.5	-	7.5	%DC	10V amplitude

Table 6. Specifications for Cell Frequency Functions.



Configuration	Min	Optimum Range for Performance	Max	
Thermocouple	J	-50°C		1025°C ± 4 °C
	K	-50°C		1000°C ± 4 °C
RTD	-135°C		250°C	± 2 °C
NTC	25°C		125°C	± 1°C
Current Out	4 mA		20 mA	± .05 mA
Voltage: In / Out	2 V		10 V	0.3 %, typical

Table 7. Suggested Sensor Selection based on Application.

Application	Recommended Wire Size	Recommended Part Numbers
Line voltage terminals	14, 16 or 18 AWG copper conductor, 600 volt insulation, moisture-resistant wire.	TTW60C, THW75C, THHN90C
Other terminals	18 AWG wire insulated for voltages and temperatures for given application.	TTW60C, THW75C, THHN90C

Table 8. Recommended Wire Sizes and Part Numbers.

Recommended Grounding Practices

Use an Earth ground or a signal ground as described below.

Earth ground (Base, Rectification Flame Amp Module, other modules optional)

1. Use to provide a connection between the base and the control panel of the equipment. Earth ground must be capable of conducting enough current to blow the breaker in the event of an internal short circuit.
2. Use wide straps or brackets to provide minimum length, maximum surface area ground conductors. If a leadwire is required, use 14 AWG copper wire.



3. Make sure that mechanically tightened joints along the ground path are free of nonconductive coatings and protected against corrosion on mating surfaces.

Signal ground

Note the 18V system ground is not electrically connected to earth ground. Follow local codes and appliance recommendations to determine if this should be connected to earth ground.

Be sure loads do not exceed the terminal ratings. Refer to the labels or terminal ratings in Table 2.

The SLATE system must be mounted in an electrical enclosure. When mounting in an electrical enclosure, provide adequate clearance for servicing, installation and removal of SLATE modules.

The maximum leadwire length is 300 feet to terminal inputs (Control, Running/Lockout Interlock).



บริษัท เอดีดี เฟอร์เนส จำกัด

ADD FURNACE CO.,LTD.

44 ซอยบรมราชชนนี 70 ถนนบรมราชชนนี แขวงศาลาธรรมสพน์ เขตทวีวัฒนา กรุงเทพฯ 10170

โทร: 02-888-3472 โทร: ออกแบบ:08-08-170-170 แฟกซ์: 02-888-3258

<https://www.add-furnace.com> E-mail: sales@add-furnace.com



32-00007-03

For more information and detailed instructions on the R8001L8001 and the entire SLATE system please refer to the SLATE User Guide located on our website at <http://combustion.honeywell.com/SLATE>

Honeywell

Automation and Control Solutions

Honeywell International Inc.
1985 Douglas Drive North
Golden Valley, MN 55422
customer.honeywell.com

® U.S. Registered Trademark.
© 2014 Honeywell International Inc.
32-00007—03 M.S. Rev. 12-14
Printed in U.S.A.