



บริษัท เอดีดี เฟอร์เนส จำกัด

ADD FURNACE CO.,LTD.

44 ซอยบรมราชชนนี 70 ถนนบรมราชชนนี แขวงศาลาธรรมสพน์ เขตทวีวัฒนา กรุงเทพฯ 10170

โทร: 02-888-3472 โทร: ออกแบบ:08-08-170-170 แฟกซ์: 02-888-3258

<https://www.add-furnace.com> E-mail: sales@add-furnace.com

Honeywell

SLATE™

Sub-Base Module

R8001S9001

INSTALLATION INSTRUCTIONS

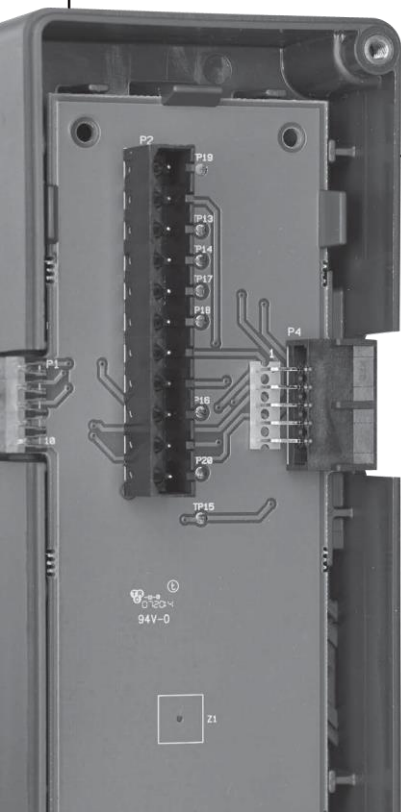



บริษัท เอดีดี เฟอร์เนส จำกัด

ADD FURNACE CO.,LTD.

44 ซอยบรมราชชนนี 70 ถนนบรมราชชนนี แขวงศาลาธรรมสพน์ เขตทวีวัฒนา กรุงเทพฯ 10170

โทร: 02-888-3472 โทร: ออกแบบ:08-08-170-170 แฟกซ์: 02-888-3258

<https://www.add-furnace.com> E-mail: sales@add-furnace.com

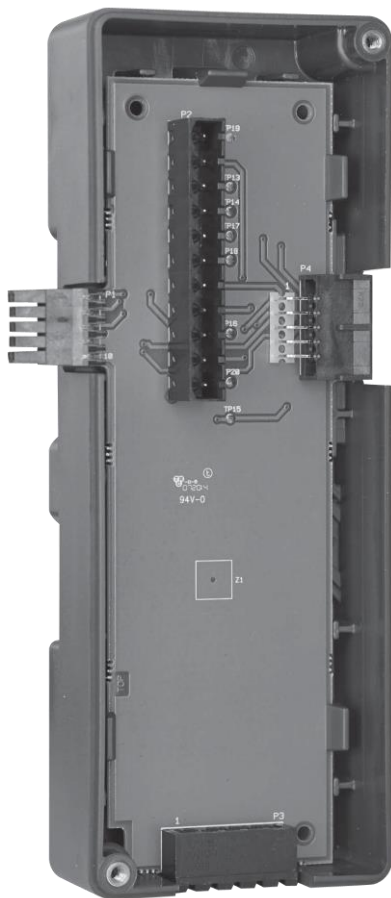

Scan for more information



Application

SLATE™ brings configurable safety and programmable logic together into one single platform. The platform can easily be customized for almost any requirement or application—offering virtually limitless development opportunities with far less complexity.

The R8001S9001 SLATE Sub-Base Module provides the ability for the SLATE system to be mounted via DIN Rail in a panel. All SLATE modules need this sub-base except for the SLATE Base Module.

Features

- Quick-mount to standard DIN-Rail
- Locking mechanism
- Provides bus connectivity to all modules
- Connections for remote mounted flame amplifiers (remote bus) and remote pushbutton reset

Specifications

Electrical Ratings:

Voltage and Frequency (from the Base): 18 VDC (± 1 VDC)

Maximum Total Connected Load: 2.5A

Terminal Ratings: See Table 1

Terminal	Description	Rating
1	18 V Power	2.5 A max including modules
2	18 V Ground	---
3	Remote Reset (Burner Control and Limit modules only)	Connect to Terminal 2 (18 V Ground) via external pushbutton



Terminal	Description	Rating
4	B (Remote Bus RS485)	Used for Remote mounted flame amplifiers
5	A (Remote Bus RS485)	Used for Remote mounted flame amplifiers

Table 1. Terminal Ratings.

Environmental Ratings

Ambient Temperature:

Operating: -20°F to +150°F (-29°C to +66°C).

Shipping: -40°F to +150°F (-40°C to +66°C)

Humidity: 95% continuous, noncondensing.

Vibration: 0.5G environment

Dimensions: See Fig. 1.

Weight: 5 oz (136 g)

Approvals

Underwriters Laboratories Inc. Listed, File: MP286

IRI acceptable.

Federal Communications Commission: Part 15, Class A

Emissions.

Mounting

DIN Rail (See Fig. 3)

Required Components

R8001A1001 SLATE Base Module

Any other SLATE modules

Optional 5-position terminal block for remote flame amplifier or remote reset button connections (Phoenix Contact p/n 1754504 or equivalent). See Fig. 2.



บริษัท เอดีดี เฟอร์เนส จำกัด

ADD FURNACE CO.,LTD.

44 ซอยบรมราชชนนี 70 ถนนบรมราชชนนี แขวงศาลาธรรมสพน์ เขตทวีวัฒนา กรุงเทพฯ 10170

โทร: 02-888-3472 โทร: ออกแบบ:08-08-170-170 แฟกซ์: 02-888-3258

<https://www.add-furnace.com> E-mail: sales@add-furnace.com

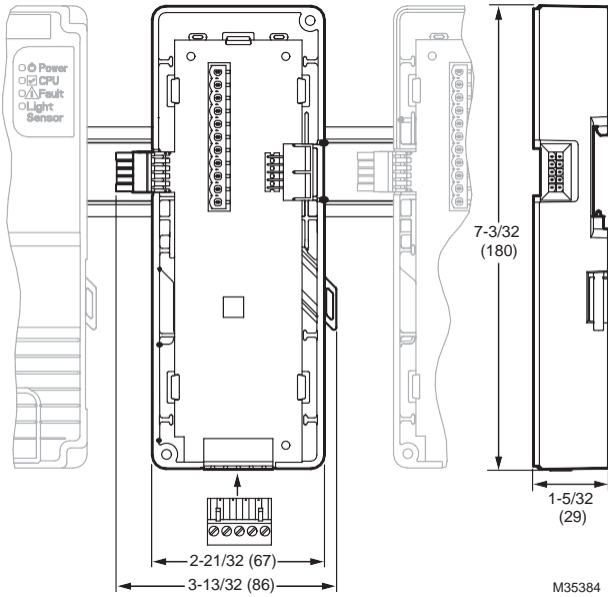

Fig. 1. Dimensions in in. (mm).



บริษัท เอดีดี เฟอร์เนส จำกัด

ADD FURNACE CO.,LTD.

44 ซอยบรมราชชนนี 70 ถนนบรมราชชนนี แขวงศาลาธรรมสพน์ เขตทวีวัฒนา กรุงเทพฯ 10170

โทร: 02-888-3472 โทร: ออกแบบ:08-08-170-170 แฟกซ์: 02-888-3258

<https://www.add-furnace.com> E-mail: sales@add-furnace.com

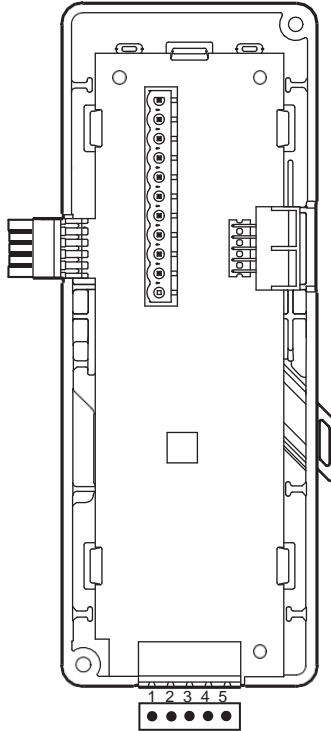

TERMINAL	DESCRIPTION
1	18V POWER
2	18V GROUND
3	REMOTE RESET (BURNER CONTROL AND LIMIT MODULES ONLY)
4	B (REMOTE BUS RS485)
5	A (REMOTE BUS RS485)

M35430

Fig. 2. Sub-base module wiring terminals.



บริษัท เอดีดี เฟอร์เนส จำกัด

ADD FURNACE CO.,LTD.

44 ซอยบรมราชชนนี 70 ถนนบรมราชชนนี แขวงศาลาธรรมสพน์ เขตทวีวัฒนา กรุงเทพฯ 10170

โทร: 02-888-3472 โทร: ออกแบบ:08-08-170-170 แฟกซ์: 02-888-3258

<https://www.add-furnace.com> E-mail: sales@add-furnace.com

Installation



WARNING

Fire or Explosion Hazard Can cause severe injury, death, or property damage.

Verification of safety requirements must be performed each time a control is installed on a burner to prevent possible hazardous burner operation.

When Installing This Product

1. Read these instructions carefully. Failure to follow them could damage the product or cause a hazardous condition.
2. Check the ratings given in the instructions and on the product to make sure the product is suitable for your application.

Mounting

1. The sub-base module can be mounted on type C 20 DIN rail.
2. Mount the sub-base module first. The sub-base has locking mechanisms on both sides of the module. Pull to unlock position. See Fig. 3.



UNLOCKED FROM DIN RAIL

LOCKED ONTO DIN RAIL

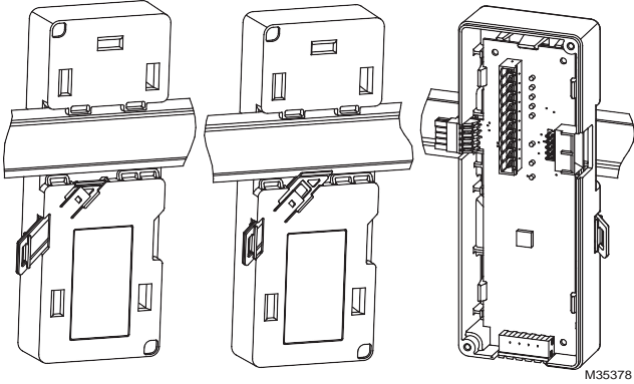
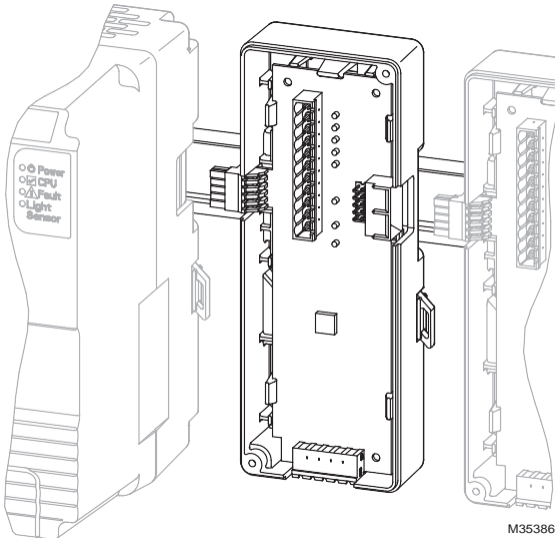

Fig. 3. Sub-base locking mechanisms.

3. Slide sub-base on the DIN rail and lock into place.
4. When securing subsequent sub-base modules make sure communication ports are aligned and locked into place. See Fig. 4.





5. After securing the sub-base module, snap the SLATE module into place and secure the module to the sub-base using screws (included with SLATE module).

Wiring

WARNING

Electrical Shock Hazard.

Can cause severe injury, death or equipment damage.

1. Disconnect the power supply before beginning installation to prevent electrical shock and equipment damage. More than one power supply disconnect can be involved.
2. Wiring must comply with all applicable codes, ordinances and regulations. See Fig. 2.
3. Wiring must comply with NEC Class 1 (Line Voltage) wiring.

Application	Recommended Wire Size	Recommended Part Numbers
Communication Lines	22 AWG two-wire twisted pair with ground, or five-wire.	Belden 8723 shielded cable or equivalent.
Other terminals	18 AWG wire insulated for voltages and temperatures for given application.	TTW60C, THW75C, THHN90C

Table 2. Recommended Wire Sizes and Part Numbers.

IMPORTANT

This equipment generates, uses and can radiate radio frequency energy and, if not installed and used in accordance with these instructions, may cause interference for radio communications.

It has been tested and found to comply with the limits of a Class A computing device of part 15 of FCC rules, which are designed to provide reasonable protection against such interference



when operated in a commercial environment. Operation of this equipment in a residential area may cause interference; in which case, the user, at their own expense, may be required to take whatever measures are required to correct this interference.

- 1. This digital apparatus does not exceed the Class A limits for radio noise, set out in the Radio Interference Regulations of the Canadian Department of Communications.*
- 2. Cable shield must be terminated to ground at both ends. If shielded cable is NOT used, use three-wire twisted cable.*

Recommended Grounding Practices

Use an Earth ground or a signal ground as described below.

Earth Ground (Base, Rectification Flame Amp Module, Other Modules Optional)

1. Use to provide a connection between the base and the control panel of the equipment. Earth ground must be capable of conducting enough current to blow the breaker in the event of an internal short circuit.
2. Use wide straps or brackets to provide minimum length, maximum surface area ground conductors. If a leadwire is required, use 14 AWG copper wire.
3. Verify that mechanically tightened joints along the ground path are free of nonconductive coatings and protected against corrosion on mating surfaces.

Signal ground

Note the 18 V system ground is not electrically connected to earth ground. Follow local codes and appliance recommendations to determine if this should be connected to earth ground.

Recommended Routing of Leadwires

- Do not run high voltage ignition transformer wires in the same conduit with the flame detector or data lines.
- Do not route flame detector or data lines in conduit with line voltage circuits.



- Enclose flame detector leadwires without armor cable in metal cable or conduit.
- Follow directions in flame detector instructions.

Be sure loads do not exceed the terminal ratings. Refer to the labels or terminal ratings in Table 1.

The SLATE system must be mounted in an electrical enclosure. When mounting in an electrical enclosure, provide adequate clearance for servicing, installation, and removal of SLATE modules.

Maximum Wire Length

- The maximum leadwire length is 300 feet to terminal inputs (Control, Running/Lockout Interlock)
- For remote reset leadwires, maximum length to remote pushbutton is 1000 feet.
- For remote bus data lines, maximum cable length depends on the number of modules connected, the noise conditions, and the cable used. The maximum of all interconnecting wires is 4000 feet.



บริษัท เอดีดี เฟอร์เนส จำกัด

ADD FURNACE CO.,LTD.

44 ซอยบรมราชชนนี 70 ถนนบรมราชชนนี แขวงศาลาธรรมสพน์ เขตทวีวัฒนา กรุงเทพฯ 10170

โทร: 02-888-3472 โทร: ออกแบบ:08-08-170-170 แฟกซ์: 02-888-3258

<https://www.add-furnace.com> E-mail: sales@add-furnace.com



32-00025-01

For more information and detailed instructions on the SLATE display please refer to the SLATE User Guide document located on our website at <http://combustion.honeywell.com/SLATE>

Honeywell

Automation and Control Solutions

Honeywell International Inc.

1985 Douglas Drive North

Golden Valley, MN 55422

customer.honeywell.com

® U.S. Registered Trademark.

© 2014 Honeywell International Inc.

32-00025—01 M.S. 11-14

Printed in U.S.A.