



บริษัท เอดีดี เฟอร์เนส จำกัด

ADD FURNACE CO.,LTD.

44 ซอยบรมราชชนนี 70 ถนนบรมราชชนนี แขวงศาลาธรรมสพน์ เขตทวีวัฒนา กรุงเทพฯ 10170

โทร: 02-888-3472 โทร: ออกแบบ:08-08-170-170 แฟกซ์: 02-888-3258

<https://www.add-furnace.com> E-mail: sales@add-furnace.com

Honeywell

RM7890A,B,C/EC7890A,B 7800 SERIES Relay Modules

INSTALLATION INSTRUCTIONS

APPLICATION

The Honeywell RM7890A,B,C/EC7890A,B Relay Modules are microprocessor based integrated burner controls for on/off automatically fired gas, oil, or combination fuel single burner applications. The RM/EC7890 Relay Module is intended to replace the RA890F,G, H Protectorelay® Primary Control. The RM/EC7890 System consists of a relay module, subbase, and amplifier. Options include keyboard display module (KDM), and remote display mounting.

Functions the RM/EC7890 provides include automatic burner on/off sequencing, flame supervision, system status indication, system or self-diagnostics and troubleshooting.

This document provides installation and static checkout instructions. Other applicable publications are:

65-0084: Q7800A,B 22-Terminal Wiring Subbase Product Data.

65-0090: S7800A Keyboard Display Module Product Data.

65-0091: S7810A Data ControlBus Module™ Product Data.

65-0095: S7820 Remote Reset Module Product Data.

65-0097: 221729C Dust Cover Packing Instructions.

65-0109: Flame Amplifiers for the 7800 SERIES Product Data.

65-0131: 221818A,C Extension Cable Assembly Product Data.

65-0229: 7800 SERIES Relay Modules Checkout and Troubleshooting.

65-0249:S7810M ModBus Module.

SPECIFICATIONS

Electrical Ratings (See Table 3):

Voltage and Frequency:

RM7890: 120 Vac (+10/-15%), 50/60 Hz (±10%).

EC7890: 220/ 240 Vac (+10%/-15%), 50/60 Hz (±10%).

Power Dissipation: 10W maximum.

Maximum Total Connected Load: 2000 VA.

Fusing Total Connected Load: 15A maximum, type SC or equivalent, fast blow.

Environmental Ratings:

Ambient Temperature:

Operating: -40°F to +140°F (-40°C to +60°C).

Storage: -40°F to +150°F (-40°C to +66°C).

Humidity: 85% relative humidity continuous, noncondensing.

Vibration: 0.5G environment.

SIL 3 Capable

SIL 3 Capable in a properly designed Safety Instrumented System. See form number 65-0312 for Certificate Agreement.

Approvals:

RM7890A,B:

Underwriters Laboratories Inc. Listed: File No. MP268, Guide No. MCCZ.

Canadian Standards Association Certified: LR9S329-3.

Factory Mutual Approved: Report No. J.I.1V9A0.AF.

Swiss RE (formerly IRI) : Acceptable.

Federal Communications Commission: Part 15, Class B, Emissions.

RM7890C:

Underwriters Laboratories Inc.: Component Recognized.

EC7890:

Factory Mutual: Approved.

EC7890A1037, RM7890A1064, RM7890B1055

Gastec—EN268, Report 115679/1.

Note: RM7890B1055 is rated cULus and CE.



EC7890A1037,
RM7890A1064 or
RM7890B1055 only.



66-1089-11



RM7890A,B,C/EC7890A,B 7800 SERIES RELAY MODULES

INSTALLATION

WARNING

Fire or Explosion Hazard.

Can cause property damage, serious injury, or death.

To prevent possible hazardous burner operation, verify safety requirements each time a control is installed on a burner.

WARNING

Electrical Shock Hazard.

Can cause personal injury, death or equipment damage.

Disconnect the power supply before beginning installation.

When Installing this Product...

1. Read these instructions carefully. Failure to follow them could damage the product or cause a hazardous condition.
2. Check the ratings given in the instructions and marked on the product to make sure the product is suitable for the application.
3. Installer must be a trained, experienced, flame safeguard service technician.
4. After installation is complete, check out the product operation as provided in these instructions.

IMPORTANT

1. *Wiring connections for the relay modules are unique; refer to Fig. 2 or the appropriate Specifications for individual subbase wiring.*
2. *Wiring must comply with all applicable codes, ordinances and regulations.*
3. *Wiring must comply with NEC Class 1 (Line Voltage) wiring.*
4. *Loads connected to the RM/EC7890 must not exceed those listed on the RM/EC7890 label or the Specifications; see Tables 3, 4, and 5.*
5. *Limits and interlocks must be rated to simultaneously carry and break current to the ignition transformer, pilot valve, and main fuel valve(s).*
6. *All external timers must be listed or component-recognized by authorities who have proper jurisdiction.*
7. *For on-off gas-fired systems, some authorities who have jurisdiction prohibit the wiring of any limit or operating contacts in series between the flame safeguard control and the main fuel valve(s).*
8. *Two flame detectors can be connected in parallel with the following exceptions:*
 - C7962 Visible Light Detector
 - C7927 Ultraviolet Detector
 - C7015/C7915 Infrared Detector

9. *This equipment generates, uses and can radiate radio frequency energy and, if not installed and used in accordance with the instructions, can cause interference with radio communications. It has been tested and found to comply with the limits for a Class B computing device of Part 15 of FCC rules which are designed to provide reasonable protection against such interference when operated in a commercial environment. Operation of this equipment in a residential area can cause interference, in which case, the users, at their own expense, may be required to take whatever measures are required to correct this interference.*
10. *This digital apparatus does not exceed the Class B limits for radio noise for digital apparatus set out in the Radio Interference Regulations of the Canadian Department of Communications.*

Location

Humidity

Install the relay module where the relative humidity never reaches the saturation point. The relay module is designed to operate in a maximum 85% relative humidity continuous, noncondensing, moisture environment. Condensing moisture can cause a safety shutdown.

Vibration

Do not install the relay module where it can be subjected to vibration in excess of 0.5G continuous maximum vibration.

Weather

The relay module is not designed to be weather tight. When installed outdoors, protect the relay module in an approved weather-tight enclosure.

Mounting Wiring Subbase

See Fig. 1 for the internal block diagram of RM/EC7890 Relay Module.

1. Mount the subbase in any position except horizontally with the bifurcated contacts pointing down. The standard vertical position is recommended. Any other position decreases the maximum ambient temperature rating.
2. Select a location on a wall, burner or electrical panel. The Q7800 can be mounted directly in the control cabinet. Be sure to allow adequate clearance for servicing, installation, access or removal of the RM/EC7890, KDM, flame amplifier, flame amplifier signal voltage probes, electrical signal voltage probes and electrical field connections.
3. For surface mounting, use the back of the subbase as a template to mark the four screw locations. Drill the pilot holes.
4. Securely mount the subbase using four no. 6 screws (not provided).



RM7890A,B,C/EC7890A,B 7800 SERIES RELAY MODULES

Wiring

⚠ WARNING

Electrical Shock Hazard.
Can cause personal injury or equipment damage.
Disconnect the power supply before beginning installation.

1. For proper subbase wiring and sequence chart, refer to Fig. 2.
2. For proper remote wiring of the KDM, refer to the Specifications for the KDM (65-0090), Data ControlBus Module™ (65-0091) or Extension Cable Assembly (65-0131).
3. Disconnect the power supply from the main disconnect before beginning installation to prevent electrical shock and equipment damage. More than one disconnect can be required.
4. All wiring must comply with all applicable electrical codes, ordinances and regulations. Wiring, where required, must comply with NEC, Class 1 (Line Voltage) wiring.
5. Use recommended wire routing of leadwires:
 - a. Do not run high voltage ignition transformer wires in the same conduit with the flame detector, Data ControlBus Module™, or Remote Reset Module wiring.
 - b. Do not route flame detector, KDM, Data ControlBus Module™, or Remote Reset Module leadwires in conduit with line voltage circuits.
 - c. Enclose flame detector leadwires without armor cable in metal cable or conduit.
 - d. Follow directions in flame detector, KDM, Data ControlBus Module™, or Remote Reset Module Instructions.

6. For KDM (KDM), because the KDM is powered from a low voltage, energy limited source, it can be mounted outside of a control panel if it is protected from mechanical damage.

NOTE: Use 13 Vdc power supply any time more than one KDM is used.

7. Use maximum wire lengths:
 - a. RM/EC7890 leadwires: The maximum leadwire length is 300 feet (91 meters) to terminal inputs (Control, Running/Lockout Interlock).
 - b. Flame Detector leadwires: The maximum flame sensor leadwire length is limited by the flame signal strength.
 - c. Remote Reset leadwires: The maximum length of wire is 1000 feet (305 meters) to a Remote Reset pushbutton.
 - d. Data ControlBus Module™: The maximum Data ControlBus Module™ cable length depends on the number of system modules connected, the noise conditions and the cable used. The maximum length of all Data ControlBus Module™ interconnecting wire is 4000 feet (1219 meters).
8. For recommended wire size and type, see Table 1.
9. The KDM, or Data ControlBus Module™ (for remote mounting) must be wired in a daisy chain configuration, 1(a)-1(a), 2(b)-2(b), 3(c)-3(c). The order of interconnection of all the devices listed above is not important. Be aware that modules on the closest and farthest end of the daisy chain configuration string require a 120 ohm (1/4 watt minimum) resistor termination across terminals 1 and 2 of the electrical connectors for connections over 100 feet (31 meters).
10. For recommended grounding practices, see Table 2.
11. Be sure loads do not exceed the terminal ratings. Refer to the label on the RM/EC7890 or to the terminal ratings in Table 3.

Table 1. Recommended Wire Sizes and Part Numbers.

Application	Recommended Wire Size	Recommended Part Numbers
Line voltage terminals	14, 16, or 18 AWG copper conductor, 600 volt insulation wire.	TTW60C, THW75C, THHN90C.
Keyboard Display Module	22 AWG two-wire twisted pair with ground, or five-wire.	Belden 8723 shielded cable or equivalent.
Data ControlBus Module™	22 AWG two-wire twisted pair with ground, or five-wire.	Belden 8723 shielded cable or equivalent.
Remote Reset Module	22 AWG two-wire twisted pair, insulated for low voltage.	—
13 Vdc full-wave rectified transformer power input.	18 AWG wire insulated for voltages and temperatures for given application.	TTW60C, THW75C, THHN90C.



บริษัท เอดีดี เฟอร์เนส จำกัด

ADD FURNACE CO.,LTD.

44 ซอยบรมราชชนนี 70 ถนนบรมราชชนนี แขวงศาลาธรรมสพน์ เขตทวีวัฒนา กรุงเทพฯ 10170

โทร: 02-888-3472 โทร: ออกแบบ:08-08-170-170 แฟกซ์: 02-888-3258

https://www.add-furnace.com E-mail: sales@add-furnace.com

RM7890A,B,C/EC7890A,B 7800 SERIES RELAY MODULES

Table 2. Recommended Grounding Practices.

Ground Type	Recommended Practice
Earth ground (subbase and relay module).	<ol style="list-style-type: none"> 1. Use to provide a connection between the subbase and the control panel of the equipment. Earth ground must be capable of conducting enough current to blow the 15A fuse (or breaker) in the event of an internal short circuit. 2. Use wide straps or brackets to provide minimum length, maximum surface area ground conductors. If a leadwire is required, use 14 AWG copper wire. 3. Make sure that mechanically tightened joints along the ground path are free of nonconductive coatings and protected against corrosion on mating surfaces.
Signal ground (Keyboard Display Module, Data ControlBus Module™)	Use the shield of the signal wire to ground the device to the signal ground terminals—3(c)—of each device. Connect the shield at both ends of the daisy chain to earth ground.

Table 3. Terminal Ratings.

Terminal Number	Description	Ratings (RM7890A,B,C)	Ratings (EC7890A,B)
G	Flame Sensor Ground	—	—
Earth G	Earth Ground ^a	—	—
L2(N)	Line Voltage Common	—	—
3	Line Voltage Supply (L1)	120 Vac (+10%/-15%), 50 or 60 Hz (±10%). ^b	220-240 Vac (=10%/-15%), 50 or 60 Hz (±10%).
4	Alarm	120 Vac, 1A pilot duty.	220-240 Vac, 1A pilot duty.
5	Unused	—	—
6	Burner Controller and Limits	120 Vac, 8A run, 43A inrush.	220-240 Vac, 5A (maximum).
7	Unused	—	—
8	Pilot Valve/Ignition.	120 Vac. ^c	220-240 Vac, 4A at P.F. = 0.5, 20A inrush.
9	Main Fuel Valve.	120 Vac. ^c	220-240 Vac, 4A at P.F. = 0.5, 20A inrush.
10	Ignition	120 Vac, 4.5A ignition. ^c	220-240 Vac, 4A at P.F. = 0.2.
F(11)	Flame Sensor	60 to 220 Vac, current limited.	60 to 220 Vac, current limited.
12 to 21	Unused.	—	—
22	Shutter	120 Vac, 0.5A (RM7890B).	220-240 Vac (EC7890B only). ^d

^a The RM/EC7890 must have an earth ground providing a connection between the subbase and the control panel or the equipment. The earth ground wire must be capable of conducting the current to blow the 15A fuse (or breaker) in event of an internal short circuit. The RM/EC7890 needs a low impedance ground connection to the equipment frame which, in turn, needs a low impedance connection to earth ground. For a ground path to be low impedance at RF frequencies, the connection must be made with minimum length conductors having maximum surface areas. Wide straps or brackets rather than leadwires are preferred. Be careful to verify that mechanically tightened joints along the ground path, such as pipe or conduit threads or surfaces held together with fasteners, are free of nonconductive coatings and are protected against mating surface corrosion.

^b 2000 VA maximum connected load to the RM/EC7890 Assembly.

^c See Tables 4 and 5 for device load combinations.

^d Requires 220-240 to 120 Vac, 10 Va minimum stepdown transformer to drive the shutter.



RM7890A,B,C/EC7890A,B 7800 SERIES RELAY MODULES

Table 4. Combinations for Terminals 8, 9, and 10.

Pilot Fuel 8	Main 9	Ignition 10
C	F	No Load
B	F	No Load
F	F	A
F	No Load	A
D	F	A
D	D	A
D	No Load	A

A	B	C	D	F
4.5A ignition	50 VA Pilot Duty plus 4.5A ignition.	180 VA ignition plus motor valves with: 660 VA inrush, 360 VA open, 250 VA hold.	2A Pilot Duty.	65 VA Pilot Duty plus motor valves with: 3850 VA inrush, 700 VA Open, 250 VA hold.

Final Wiring Check

1. Check the power supply circuit. The voltage and frequency tolerance must match those of the RM/EC7890. A separate power supply circuit can be required for the RM/EC7890. Add the required disconnect means and overload protection.
2. Check all wiring circuits and complete the Static Checkout in Table 7 before installing the RM/EC7890 on the subbase.
3. Install the relay module.
4. Restore the panel power.



CAUTION

Equipment Damage Hazard.

Can cause equipment damage or equipment failure.

Do not perform a dielectric test with the RM/EC7890 installed. Internal surge protectors break down and conduct a current, causing the RM/EC7890 to fail the dielectric test or possibly destroy the internal lightning and high current protection.

STATIC CHECKOUT

After checking all wiring, perform this checkout before installing the RM/EC7890 on the subbase. These tests verify the Q7800 Wiring Subbase is wired correctly, and the external controllers, limits, interlocks, actuators, valves, transformers, motors and other devices are operating properly.



WARNING

Explosion Hazard.

Can cause serious injury, death or equipment damage.

1. Close all manual fuel shutoff valve(s) before starting these tests.
2. Use extreme care while testing the system. Line voltage is present on most terminal connections when power is on.
3. Open the master switch before installing or removing a jumper on the subbase.
4. Before continuing to the next test, be sure to remove test jumper(s) used in the previous test.
5. Replace all limits and interlocks that are not operating properly. Do not bypass limits and interlocks.

Equipment Recommended

1. Voltmeter (1M ohm/volt minimum sensitivity) set on the 0 to 300 Vac scale.
2. Two jumper wires, No. 14 wire, insulated, 12 in. (304.8 mm) long with insulated alligator clips at both ends. Note that an ammeter can be used in place of a jumper to confirm current draw of loads. (ignition, pilot valve and main valve).

General Instructions

1. Perform all applicable tests listed in the Static Checkout, Table 6, in the order listed.
2. Make sure all manual fuel shutoff valves are closed.
3. For each test, open the master switch and install the jumper wires between the subbase wiring terminals listed in the Test Jumpers column.
4. Close the master switch before observing the operation.
5. Read the voltage between the subbase wiring terminals listed in the Voltmeter column.
6. If there is no voltage or the operation is abnormal, check the circuits and external devices as described in the last column.
7. Check all wiring for proper connections, tight terminal screws, and appropriate wire and wiring techniques.
8. Replace all damaged or incorrectly sized wires.
9. Replace faulty controllers, limits, interlocks, actuators, valves, transformers, motors and other devices, as required.
10. Make sure normal operation is obtained for each required test before continuing the checkout.
11. After completing each test, be sure to remove the test jumper(s).



บริษัท เอดีดี เฟอร์เนส จำกัด

ADD FURNACE CO.,LTD.

44 ซอยบรมราชชนนี 70 ถนนบรมราชชนนี แขวงศาลาธรรมสพน์ เขตทวีวัฒนา กรุงเทพฯ 10170

โทร: 02-888-3472 โทร: ออกแบบ:08-08-170-170 แฟกซ์: 02-888-3258

https://www.add-furnace.com E-mail: sales@add-furnace.com

RM7890A,B,C/EC7890A,B 7800 SERIES RELAY MODULES

WARNING

Explosion Hazard.
Can cause serious injury or death.
Be sure all manual fuel shutoff valves are closed.

IMPORTANT

Low fuel pressure limits, if used, could be open.
Bypass them with jumpers for the remaining static tests (if required).

Table 5. Static Checkout.

Test No.	Test Jumpers	Voltmeter	Normal Operation	If Operation is Abnormal, Check the Items Listed Below
1	—	3-L2	Line Voltage.	1. Master switch. 2. Power connected to the master switch. 3. Overload protection (fuse, circuit breaker, etc.) has not opened the power line.
2	—	6-L2	Line Voltage.	1. Limits. 2. Burner control.
3	3-10	—	Ignition spark (if ignition transformer is connected to terminal 10).	1. Watch for spark or listen for buzz. a. Ignition electrodes are clean b. Ignition transformer is okay.
4	3-8	—	1. Ignition spark (if ignition transformer is connected to terminal 8). 2. Automatic pilot valve opens (if connected to terminal 8 or main valve if DSI application). NOTE: Refer to wiring diagram of system being tested.	1. Watch for spark or listen for buzz: a. Ignition electrodes are clean. b. Ignition transformer is okay. 2. Listen for click or feel head of valve for activation: a. Actuator, if used. b. Pilot valve.
5	3-9	—	Automatic fuel valve(s) opens. (If using direct spark ignition, check the second stage fuel valve(s).)	Same as test number 4. If using direct spark ignition, check the first stage fuel valve(s) instead of the pilot valve.
6	3-4	—	Alarm (if used) turns on.	1. Alarm.



CAUTION

Equipment Damage Hazard.
Can cause serious equipment damage.

After completing these tests, open the master switch, remove all test jumpers from the subbase terminals, and remove any bypass jumpers from the low fuel pressure limits to prevent equipment damage.



RM7890A,B,C/EC7890A,B 7800 SERIES RELAY MODULES

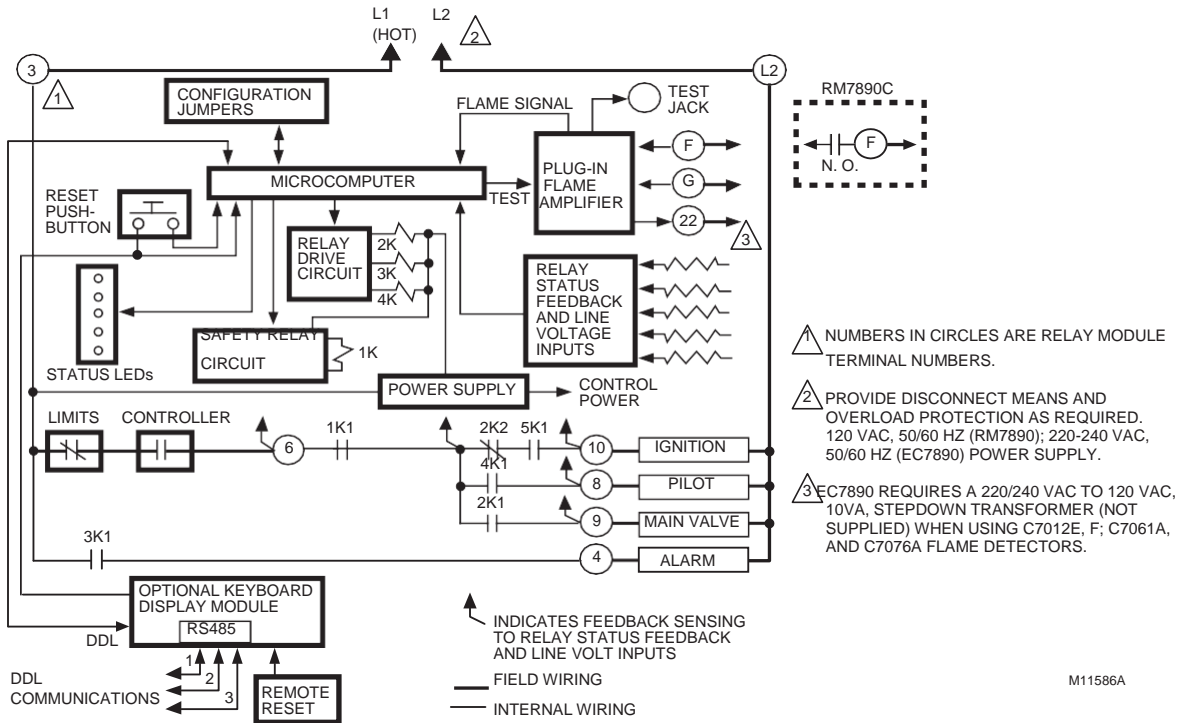
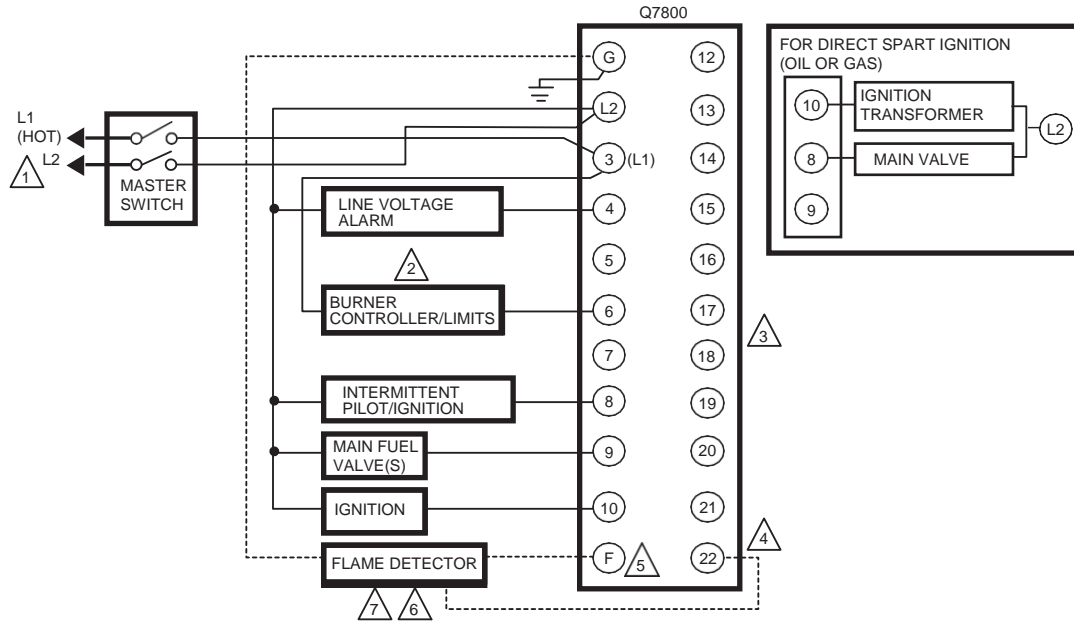

Fig. 1. Internal block diagram of the RM/EC7890.



RM7890A,B,C/EC7890A,B 7800 SERIES RELAY MODULES



	00	00	4/10	20			
	INITIATE	STANDBY	SAFE-START	PFEP 4 OR 10 SEC	MFEP	RUN	STANDBY
LED DISPLAY	● POWER ○ ○ ○	● POWER ○ ○ ○	● POWER ○ ○ ○	● POWER ● PILOT ● FLAME ○ MAIN ○ ALARM	● POWER ● PILOT ● FLAME ● MAIN ○ ALARM	● POWER ● PILOT ● FLAME ● MAIN ○ ALARM	● POWER ○ ○ ○
BURNER START				IGNITION (10) (9)			
				INTERMITTENT PILOT (8)			
					MAIN VALVE (9)		(9)
OPERATING CONTROLLER AND LIMITS				LIMITS AND BURNER CONTROL CLOSED (3) TO (6)			
FLAME SIGNAL		SAFE START CHECK			FLAME PROVING		S S C

1 120V, 50/60 HZ (RM7890) 220-240, 50/60 HZ (EC7890) POWER SUPPLY. PROVIDE DISCONNECT MEANS AND OVERLOAD PROTECTION AS REQUIRED.

2 INSTALL ALINE VOLTAGE CONTROLLER IN SERIES WITH THE LIMITS. IF USING A LOW VOLTAGE CONTROLLER IS DESIRABLE, INSTALL AN EXTERNAL RELAY WITH THE N.O. CONTACTS IN SERIES WITH THE LIMITS. THE LOW VOLTAGE RELAY COIL WILL BE IN THE LOW VOLTAGE CONTROLLER CIRCUIT. NOTE THAT IT MAY BE NECESSARY TO PROVIDE AN EXTERNAL LOW VOLTAGE TRANSFORMER.

3 DO NOT CONNECT ANY WIRES TO UNUSED TERMINALS.

4 TERMINAL 22 IS ONLY ON THE RM/EC7890B.

5 FOR CONTINUOUS OR STANDING PILOT, USE THE RM7890C. WHEN USING RM/EC7890A OR B; INSTALL AN EXTERNAL RELAY TO SWITCH THE F LEAD. THE RELAY MUST HAVE GOLD-CLAD OR GOLD-FLASH CONTACTS AND A LINE VOLTAGE COIL. POWER THE RELAY COIL FROM THE Q7800 SUBBASE TERMINAL 8. CONNECT THE RELAY CONTACTS BETWEEN THE F LEAD OF THE DETECTOR AND THE F TERMINAL OF THE Q7800 SUBBASE. THE R4222N1002 OR R4222V1002 RELAY IS ACCEPTABLE TO USE IN THIS TYPE OF APPLICATION. USE THE N.O. PILOT DUTY CONTACTS.

6 USING EC7890, A 220-240 VAC TO 120 VAC, 10 VA MINIMUM STEP-DOWN TRANSFORMER (NOT PROVIDED) MUST BE USED TO DRIVE THE SHUTTER (C7012E,F; C7061; C7076A,D DETECTORS).

7 SEE FLAME DETECTOR SPECIFICATION FOR CORRECT WIRING.

8 RM7890A1031 PFEP IS 30 SECONDS FIXED. RM7890B1030 PFEP IS 10 SECONDS FIXED.

9 MAIN FUEL VALVE IS ENERGIZED AND IGNITION (TERMINAL 10) IS TURNED OFF DURING PFEP ONCE FLAME IS PROVEN.

EXCEPTIONS:
 RM7890A1031 HAS A FIXED 30 SECOND PFEP
 RM7890B1030 HAS A FIXED 10 SECOND PFEP
 RM7890A1064, RM7890B1055 AND EC7890A1037
 JR1 INTACT - 10 SECOND FIXED PFEP, IGNITION (TERMINAL 10) SHUTS OFF AT 6 SECONDS.
 JR1 CLIPPED - 4 RECOND S FIXED PFEP, IGNITION (TERMINAL 10) SHUTS OFF AT 2 SECONDS.

M23305C

Fig. 2. Wiring subbase and operating sequence chart for RM/EC7890.



RM7890A,B,C/EC7890A,B 7800 SERIES RELAY MODULES

Mounting RM/EC7890 Relay Module

1. Mount the RM/EC7890 vertically on the Q7800 Subbase, or mount horizontally with the knife blade terminals pointing down. When mounted on the Q7800A, the RM/EC7890 must be in an electrical enclosure.
2. When mounting in an electrical enclosure, provide adequate clearance for servicing, installation and removal of the RM/EC7890, KDM, flame amplifier, flame amplifier signal voltage probes, electrical signal voltage probes, and electrical connections.
 - a. Allow an additional two inches (51 mm) below the RM/EC7890 for flame amplifier mounting.
 - b. Allow an optional three-inch (76 mm) minimum to both sides of the RM/EC7890 for electrical signal voltage probes.

3. Make sure no subbase wiring is projecting beyond the terminal blocks. Tuck in wiring against the back of the subbase so it does not interfere with the knife blade terminals or bifurcated contacts.

IMPORTANT

Install the RM/EC7890 with a plug-in motion rather than a hinge action.

4. Mount the RM/EC7890 by aligning the four L-shaped corner guides and knife blade terminals with the bifurcated contacts on the wiring subbase and securely tightening the two screws without deforming the plastic.

Mounting Other System Components (Fig. 3)

Refer to the applicable specifications for mounting other system components.

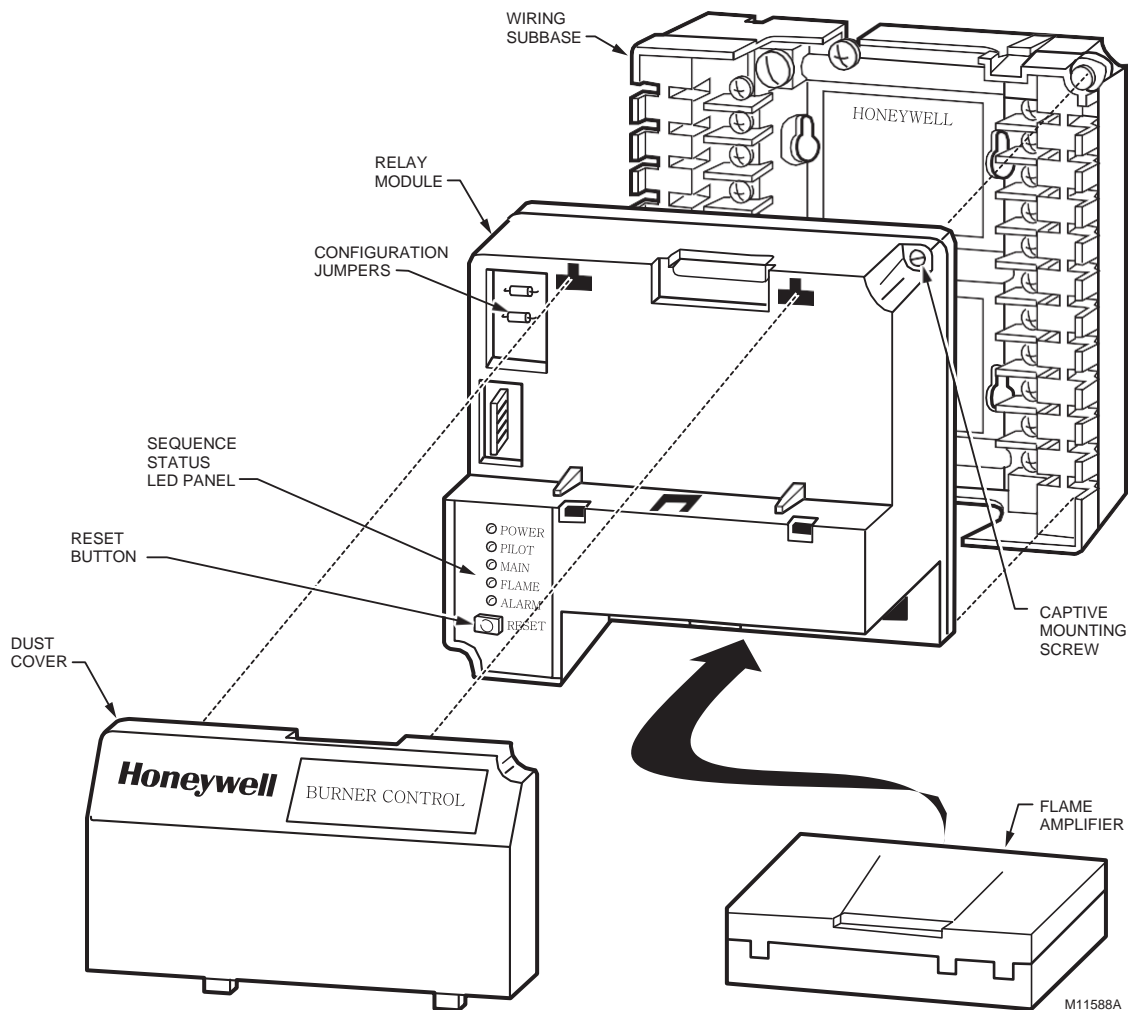

Fig. 3. RM/EC7890 Relay Module exploded view.



RM7890A,B,C/EC7890A,B 7800 SERIES RELAY MODULES

PRINCIPAL TECHNICAL FEATURES

The RM/EC7890 provides all customary flame safeguard functions as well as significant advancements in safety, annunciation, and system diagnostics.

Safety Shutdown (Lockout) Occurs if:

1. INITIATE PERIOD
 - a. AC line power errors occurred, see Operation.
 - b. Configuration jumpers have been changed (after 200 hours).
 - c. Four minute INITIATE period has been exceeded.
2. STANDBY PERIOD
 - a. Flame signal is present after 240seconds.
 - b. Ignition/intermittent pilot valve terminal is energized.
 - c. Internal system fault occurred.
 - d. Main valve terminal is energized.
 - e. Three second (two seconds for EC7890A1037, RM7890A1064 and RM7890B1055) Flame Failure Response Time (FFRT) Amplifier is installed and configuration jumper is selected for relight (see Table 3).
3. SAFE START CHECK (EXCEPT RM7890C)
 - a. Ignition/intermittent pilot valve terminal is energized.
 - b. Internal system fault occurred.
 - c. Main valve terminal is energized.
4. PILOT FLAME ESTABLISHING PERIOD (PFEP)
 - a. Ignition/intermittent pilot valve terminal is not energized.
 - b. Internal system fault occurred.
 - c. Main valve terminal is energized.
 - d. No flame present at end of PFEP.
5. RUN PERIOD
 - a. Ignition terminal is energized.
 - b. Internal system fault occurred.
 - c. Main valve terminal is not energized.
 - d. No flame present and configuration jumper is selected for lockout.
 - e. Pilot valve terminal is not energized.

OPERATION**Sequence of Operation**

The RM/EC7890 has the operating sequences listed below; see Fig. 2. The RM/EC7890 LED provide positive visual indication of the program sequence: POWER, PILOT, FLAME, MAIN and ALARM.

Initiate

The RM/EC7890 enters the INITIATE sequence when the relay module is powered. The RM/EC7890 can also enter the INITIATE sequence if the relay module verifies voltage fluctuations of +10/-15% or frequency fluctuations of $\pm 10\%$ during any part of the operating sequence. The INITIATE sequence lasts for ten seconds unless the voltage or frequency tolerances are not met. When the tolerances are not met, a hold condition is initiated and is displayed on the optional KDM for at least five seconds. When the tolerances

are met, the INITIATE sequence restarts. If the condition is not corrected and the hold condition exists for four minutes, the RM/EC7890 locks out. Causes for hold conditions in the INITIATE sequence:

- a. AC line dropout detection.
- b. AC line noise that can prevent a sufficient reading of the line voltage inputs.
- c. Brownouts caused by a low line voltage.

NOTE: If a 3.0 second flame failure response amplifier is installed and configuration jumper JR2 is intact, the RM/EC7890 locks out. JR2 must be clipped.

Standby

The RM/EC7890 is ready to start an operating sequence when the operating control input (terminal 6) recognizes a call for heat. The burner switch, limits, operating limit control and all microcomputer monitored circuits must be in the correct state for the RM/EC7890 to continue into the Safe Start Check.

Normal Start-Up Safe Start Check (Except RM7890C)

The RM/EC7890 verifies that a flame or flame simulating condition does not exist and proceeds into the Ignition Trial. If a flame or flame simulating condition is present, the RM/EC7890 remains in the STANDBY period. RM7890C checks its internal components for flame simulating conditions.

Ignition Trials

- a. Pilot Flame Establishing Period (PFEP):
 - (1) The pilot valve and ignition transformer, terminals 8 and 10, are energized. The RM/EC7890 has an intermittent pilot valve, terminal 8. RM7890C closes internal relay contact in the "F" lead.
 - (2) Flame must be proven by the end of the four- or ten-second PFEP (30 seconds for RM7890A1031) or a safety shutdown occurs.
 - (3) Once flame is proven, the ignition, terminal 10, is de-energized and the main valve, terminal 9, is energized.
 - (a) The RM7890B1030 finishes the 4- or 10-second PFEP before the main valve is energized.
 - (b) The RM7890A1064, RM7890B1055/EC7890A1037 with JR1 intact completes 10 second PFEP, shutting off ignition (Terminal 10) at 6 seconds. When the JR1 clipped these devices complete a 4 second PFEP, shutting off ignition (terminal 10) at 2 seconds.

Run

The RM/EC7890 is now in RUN and remains in RUN until the controller input, terminal 6, opens, indicating that the demand is satisfied or a limit has opened.



RM7890A,B,C/EC7890A,B 7800 SERIES RELAY MODULES

SETTINGS AND ADJUSTMENTS

Selectable Site-Configurable Jumpers

The RM/EC7890 has two site-configurable jumper options, see Fig. 4 and Table 7. If necessary, clip the site-configurable jumpers with side cutters and remove the resistors from the relay module.

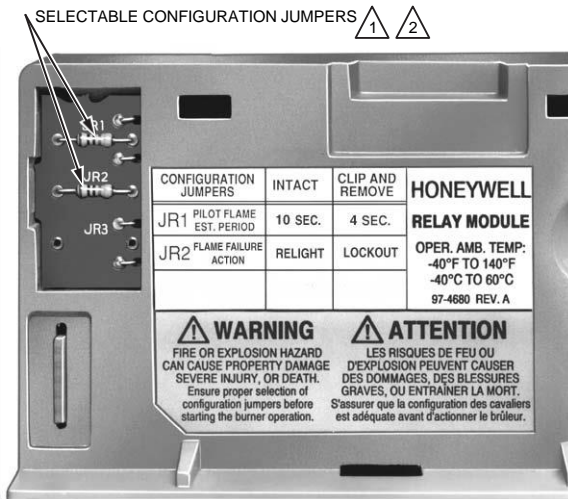

1 JR2 REMOVED FROM RM7890C.

2 RM7890A1031 PFEP IS FIXED AT 30 SECONDS, IF JR1 IS INTACT OR CLIPPED.

M11589A

Fig. 4. Selectable site-configurable jumpers.

SERVICE NOTE

Clipping and removing a site-configurable jumper enhances the level of safety. If using three-second amplifier, site-configurable jumper JR2 must be clipped and removed. If not removed, an F46 Lockout occurs.

Table 6. Site-Configurable Jumper Options.

Jumper Number	Description	Intact	Clipped ^e
JR1 ^{a, f}	Pilot Flame Establishing Period (PFEP)	10 seconds ^b	4 seconds ^b
JR2 ^c	Flame Failure Action	Relight ^d	Lockout

^a Not Applicable for RM7890A1031 (30 second PFEP). JR1 removed.

^b 30 seconds for RM7890A1031.

^c Not applicable for RM7890C (Standing Pilot).

^d The Relight feature (JR2 intact) requires a 0.8 second FFRT Flame Amplifier. The EC/RM7890 locks out and indicates a Fault 46 if a 3 second FFRT is used and jumper JR2 is not clipped and removed.

^e Clipping and removing a site-configurable jumper after 200 hours of operation results in a hard lockout, code 110.

^f For RM7890A1064, RM7890B1055 and EC7890A1037
Intact—Fixed 10 seconds PFEP, Ignition (terminal 10) shuts off at 6 seconds.
Clipped—Fixed 4 seconds PFEP, Ignition (terminal 10) shuts off at 2 seconds.