



บริษัท เอดีดี เฟอร์เนส จำกัด

ADD FURNACE CO.,LTD.

44 ซอยบรมราชชนนี 70 ถนนบรมราชชนนี แขวงศาลาธรรมสพน์ เขตทวีวัฒนา กรุงเทพฯ 10170

โทร: 02-888-3472 โทร: ออกแบบ:08-08-170-170 แฟกซ์: 02-888-3258

<https://www.add-furnace.com> E-mail: sales@add-furnace.com

Honeywell | Industrial & Commercial Thermal

**krom
schroder**

Burner control units BCU 460, BCU 465

Technical Information · GB

6 Edition 03.16l

- Replaces the local control cabinet
- For burners in intermittent operation or in continuous operation
- Flame control by UV, ionization or a further option of using the furnace chamber temperature
- Display of the program status, unit parameters and flame signal; Manual mode for burner adjustment and for diagnostic purposes
- Visualization and adaptation to the specific application via the PC programming and diagnostic software BCSoft to simplify logistics management.





บริษัท เอดีดี เฟอร์เนส จำกัด

ADD FURNACE CO.,LTD.

44 ซอยบรมราชชนนี 70 ถนนบรมราชชนนี แขวงศาลาธรรมสพน์ เขตทวีวัฒนา กรุงเทพฯ 10170

โทร: 02-888-3472 โทร: ออกแบบ:08-08-170-170 แฟกซ์: 02-888-3258

https://www.add-furnace.com E-mail: sales@add-furnace.com

Contents

Burner control units BCU 460, BCU 465 1

Contents 2

1 Application 5

1.1 Examples of application 7

1.1.1 BCU 460: Modulating-controlled burner 7

1.1.2 BCU 460.L: Two-stage-controlled burner. 8

1.1.3 BCU 465.L: Single-stage-controlled burner with
pneumatic air/gas ratio control system 9

1.1.4 BCU 465.L: Single-stage-controlled burner 10

1.1.5 BCU 460.B1 for PROFIBUS DP. 11

1.1.6 BCU 460.D: High temperature equipment 11

2 Certification 12

3 Function 13

3.1 Connection diagrams. 13

3.1.1 BCU 460.E1. 13

3.1.2 BCU 460. 14

3.1.3 BCU 465.E1. 15

3.1.4 BCU 465 16

3.1.5 BCU 465T.E1 17

3.1.6 BCU 465T 18

3.1.7 BCU 460.P.E1 with industrial plug connector 19

3.1.8 BCU 460.P with industrial plug connector. 20

3.1.9 BCU 465.P.E1 with industrial plug connector 21

3.1.10 BCU 465.P with industrial plug connector. 22

3.1.11 BCU 460.B1.E1 23

3.1.12 BCU 460.B1 24

3.1.13 BCU 465.B1. 25

3.1.14 BCU 465.B1 26

3.1.15 BCU 465T.B1.E1. 27

3.1.16 BCU 465T..B1 28

3.2 BCU.P with 16-pin industrial plug connector. 29

3.3 PROFIBUS DP 30

3.3.1 Safety-related control signals. 30

3.3.2 BCSoft. 31

3.3.3 Configuration, Master-Slave procedure 31

3.3.4 Addressing. 31

3.3.5 Network technology. 32

3.3.6 Configuration. 32

3.3.7 Bus communication. 32

3.4 BCU 460 program sequence 34

3.5 BCU 465 program sequence 36

3.6 Program status and fault messages. 39

4 Parameters 41

4.1 Scanning the parameters. 42

4.2 Flame control 43

4.2.1 Burner flame signal. 43

4.2.2 Switch-off threshold of the flame amplifier. 43

4.2.3 High temperature operation in the case of BCU.D2 or
BCU.D3 44

4.2.4 UVS check 46

4.3 Behaviour in start-up position/standby 47

4.3.1 Flame-simulation check in start-up position/
standby. 47

4.3.2 Position indicator input on BCU 465T.O (POC) 48

4.3.3 Minimum burner pause time tBP. 49

4.4 Behaviour during start-up 50

4.4.1 Safety time on start-up tSA 50

4.4.2 Minimum burner on time tB. 50

4.4.3 Flame proving period tFS. 50

4.4.4 Burner start-up attempts 50

4.5 Behaviour during operation. 52



บริษัท เอดีดี เฟอร์เนส จำกัด

ADD FURNACE CO.,LTD.

44 ซอยบรมราชชนนี 70 ถนนบรมราชชนนี แขวงศาลาธรรมสพน์ เขตทวีวัฒนา กรุงเทพฯ 10170

โทร: 02-888-3472 โทร: ออกแบบ:08-08-170-170 แฟกซ์: 02-888-3258

https://www.add-furnace.com E-mail: sales@add-furnace.com

4.5.1 Safety time during operation t_{SB} for V1 and V2.	52	6 Project planning information	67
4.5.2 Fault lock-out or restart.	52	6.1 Cable selection	67
4.5.3 Immediate fault lock-out after installation fault.	53	6.1.1 Ionization cable.	67
4.5.4 Program status on last fault	54	6.1.2 Ignition cable.	67
4.6 Air valve control on BCU.L.	55	6.1.3 UV cable	67
4.6.1 Purge.	55	6.2 Ignition electrode.	67
4.6.2 Cooling in start-up position/standby.	56	6.2.1 Electrode distance	67
4.6.3 Air valve opens in the case of external activation (not during start-up)	56	6.2.2 Star electrodes	67
4.6.4 Air valve opens in the case of external activation (even during start-up)	57	6.3 Calculating the safety time t_{SA}	68
4.6.5 Air valve opens with valve V1	57	6.4 Minimum burner on time	69
4.6.6 Air valve opens with valve V2	57	6.5 Safety interlock (Limits)	69
4.6.7 Low fire over run-time t_{KN} after a controlled shut-down	58	6.6 Protection of safety-relevant outputs.	69
4.6.8 Behaviour of the air valve after a fault lock-out.	59	6.7 Emergency stop	69
4.7 Extended air control with BCU 465.L	60	6.7.1 In the event of fire or electric shock	69
4.7.1 Air flow monitoring during purging (BCU 465.L)	60	6.7.2 Triggered by the safety interlock (limits)	69
4.7.2 Pre-ventilation time t_{VL} before start-up (BCU 465.L).	61	6.8 Reset.	70
4.7.3 Air flow monitoring during operation (BCU 465.L)	62	6.8.1 Parallel reset.	70
4.7.4 Delayed air flow monitoring (BCU 465)	63	6.8.2 Permanent remote reset	70
4.7.5 Post-ventilation time t_{NL} after a controlled shut-down (BCU 465.L)	63	6.8.3 Automatic remote reset (PLC)	70
4.7.6 Pre-ventilation time after safety shut-down (BCU 465.L)	64	6.9 Burner start.	70
4.7.7 Pre-ventilation for restart /start-up attempts (BCU 465.L).	64	6.10 Restart and start-up attempts	70
4.7.8 Pre-ventilation after reset (BCU 465.L)	64	6.11 Fault signalling	71
4.8 Manual mode	65	6.12 Overload protection.	71
4.8.1 Manual mode limited to 5 minutes.	65	6.13 Installation	71
5 Selection	66	6.14 Wiring.	72
5.1 Type code	66	6.15 BCU and BCU..E1 (with and without adapted power management)	72
		6.16 Signal distributor board	72
		6.17 PROFIBUS DP.	73
		6.17.1 Safety-related control signals	73
		6.17.2 Wiring the PROFIBUS plug connector.	73
		6.17.3 E M C	73



บริษัท เอดีดี เฟอร์เนส จำกัด

ADD FURNACE CO.,LTD.

44 ซอยบรมราชชนนี 70 ถนนบรมราชชนนี แขวงศาลาธรรมสพน์ เขตทวีวัฒนา กรุงเทพฯ 10170

โทร: 02-888-3472 โทร: ออกแบบ:08-08-170-170 แฟกซ์: 02-888-3258

https://www.add-furnace.com E-mail: sales@add-furnace.com

6.17.4 Unit replacement.73	10 Legend	88
6.17.5 Status and fault messages for PROFIBUS DP.74	11 Glossary89
6.18 Third gas valve (can be shut down) on BCU 460.L and BCU 465	76	11.1 Waiting time tW.	89
6.19 BCU switched off.	77	11.2 Safety time on start-up tSA.	89
6.20 Note on EC-type examination.	77	11.3 Ignition time tZ	89
6.21 Mains switch	77	11.4 Flame simulation/Flame simulation delay time tLV. . .	89
6.22 SIL /PL level for thermoprocessing equipment	77	11.5 Safety time during operation tSB.	90
6.23 Changing parameters.	78	11.6 Flame signal	90
7 Flame control79	11.7 Fault lock-out.90
7.1 With ionization sensor.	79	11.8 Safety interlocks (Limits).	90
7.2 With UV sensor	79	11.9 Pilot gas valve V1	90
7.3 Via the temperature in high temperature equipment.	80	11.10 Main gas valve V2	90
8 Accessories81	11.11 Continuous operation.91
8.1 High-voltage cable	81	11.12 Air valve.	91
8.2 Industrial plug connector, 16-pin.	81	11.13 Diagnostic coverage DC.	91
8.3 PROFIBUS plug connector	81	11.14 Mode of operation.	91
8.4 BCSof	82	11.15 Safe failure fraction SFF	91
8.4.1 Opto-adapter.82	11.16 Probability of dangerous failure PFHD	91
8.5 "Changed parameters" stickers82	11.17 Mean time to dangerous failure MT TFD91
8.6 External securing bar.83		
8.7 Fastening set	83		
8.8 Radio interference suppressed electrode plugs.	83		
9 Technical data84		
9.1 BCU..B185		
9.2 PROFIBUS DP	85		
9.3 Safety-specific characteristic values.86		
9.4 Control elements87		
9.5 Installation.87		



บริษัท เอดีดี เฟอร์เนส จำกัด

ADD FURNACE CO.,LTD.

44 ซอยบรมราชชนนี 70 ถนนบรมราชชนนี แขวงศาลาธรรมสพน์ เขตทวีวัฒนา กรุงเทพฯ 10170

โทร: 02-888-3472 โทร: ออกแบบ:08-08-170-170 แฟกซ์: 02-888-3258

<https://www.add-furnace.com> E-mail: sales@add-furnace.com

Application



The BCU unites the functionally interrelated components of automatic burner control unit, ignition transformer, Manual/Automatic mode and display of operating and fault statuses in a compact metal housing.

1 Application

The burner control units BCU 460 and BCU 465 control, ignite and monitor gas burners for intermittent or continuous operation. As a result of their fully electronic design, they react quickly to various process requirements and are therefore suitable for frequent cycling operation. They can be used for directly ignited industrial burners of unlimited capacity. The burners may be modulating or stage-controlled. The BCU is installed near the burner to be monitored.

On industrial furnaces, the BCU reduces the load on the central furnace control by taking over tasks that only relate to the burner, for example it ensures that the burner always ignites in a safe condition after it has been restarted.

The optional air valve control on the BCU..L assists the furnace control for cooling, purging and capacity control tasks.

The BCU 465..L is fitted with air flow monitoring and preand post-ventilation for use on recuperative burners.

The program status, the unit parameters and the level of the flame signal can be read directly from the unit.

The burner can be controlled manually for commissioning and diagnostic purposes.

If the local requirements on the burner control unit change, the PC software BCSoft can be adjusted to the unit parameters of the application by using the optical interface.



บริษัท เอดีดี เฟอร์เนส จำกัด

ADD FURNACE CO.,LTD.

44 ซอยบรมราชชนนี 70 ถนนบรมราชชนนี แขวงศาลาธรรมสพน์ เขตทวีวัฒนา กรุงเทพฯ 10170

โทร: 02-888-3472 โทร: ออกแบบ:08-08-170-170 แฟกซ์: 02-888-3258

<https://www.add-furnace.com> E-mail: sales@add-furnace.com

Application

*Roller hearth kiln in
the ceramics
industry*



*BCU on radiant
tube burner*



*Hardening
furnace with lots
of industrial
burners located
side-by-side*



The service personnel is supported by a convenient visualization system of the input and output signals and the error history.

The new power management scheme reduces installation and wiring costs. The power for the valves and ignition transformer is supplied via the power supply of the BCU, protected by a replaceable fine-wire fuse.

The conventional wide-spread systems used in industrial furnace and kiln construction require bridging of large distances for signal processing. The optionally available BCU..B1 for connection to the PROFIBUS DP fieldbus is equipped for this purpose.

As a standardized fieldbus system, the PROFIBUS DP considerably reduces development, installation and commissioning costs compared to conventional wiring.

The use of a standard bus system offers massive benefits compared to manufacturer-specific bespoke solutions. Time-tested hardware components, standardized connection methods and a series of tools of bus diagnostics and optimization are available on the market from a whole range of manufacturers. The widespread use of the system ensures that the planning and service personnel are very familiar with how the system operates and how to handle it and can therefore operate the system efficiently.



บริษัท เอดีดี เฟอร์เนส จำกัด

ADD FURNACE CO.,LTD.

44 ซอยบรมราชชนนี 70 ถนนบรมราชชนนี แขวงศาลาธรรมสพน์ เขตทวีวัฒนา กรุงเทพฯ 10170

โทร: 02-888-3472 โทร: ออกแบบ:08-08-170-170 แฟกซ์: 02-888-3258

<https://www.add-furnace.com> E-mail: sales@add-furnace.com

Application

1.1 Examples of application

1.1.1 BCU460:Modulating-controlled burner

Control: continuous.

The external control system moves the butterfly valve for air to ignition position. The burner starts at low-fire rate, and a controller controls the burner capacity via the butterfly valve for air after the operating state has been signalled.

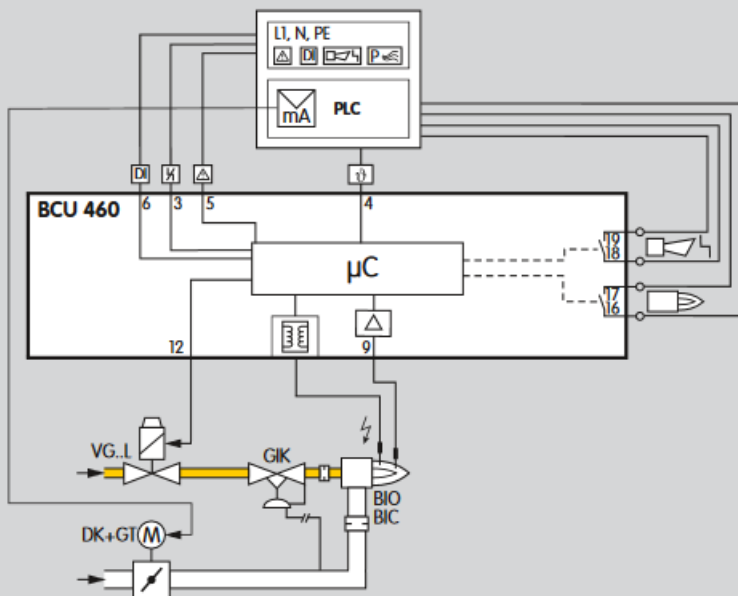



บริษัท เอดีดี เฟอร์เนส จำกัด

ADD FURNACE CO.,LTD.

44 ซอยบรมราชชนนี 70 ถนนบรมราชชนนี แขวงศาลาธรรมสพน์ เขตทวีวัฒนา กรุงเทพฯ 10170

โทร: 02-888-3472 โทร: ออกแบบ:08-08-170-170 แฟกซ์: 02-888-3258

<https://www.add-furnace.com> E-mail: sales@add-furnace.com

Application

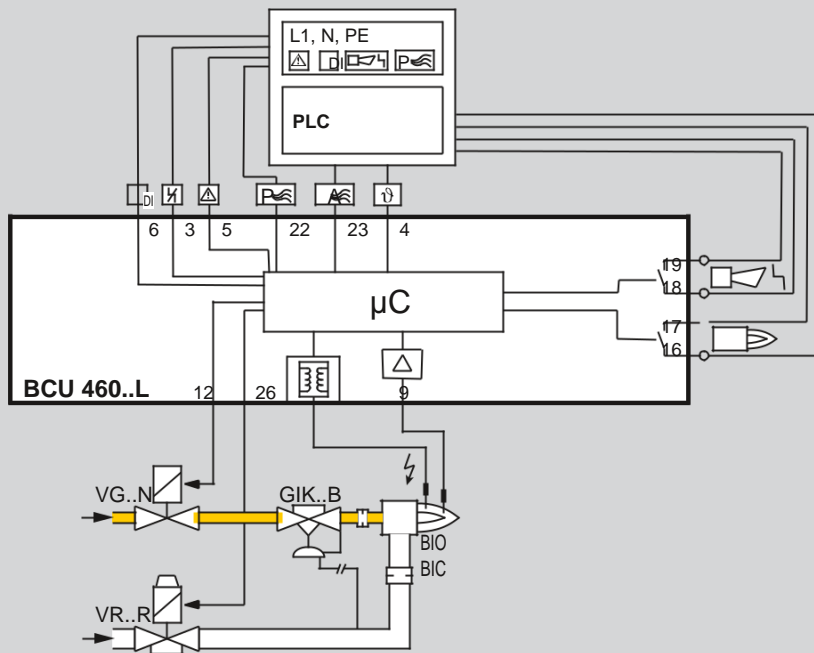

1.1.2 BCU 460..L: Two-stage-controlled burner

Control: ON/OFF or ON/HIGH/LOW/OFF intermittent operation.

The BCU supports the cooling and purging processes. The burner starts at low-fire rate. When the operating state is reached, the BCU advises the control unit. The PLC can now pulse the air valve in order to control the burner capacity.



บริษัท เอดีดี เฟอร์เนส จำกัด

ADD FURNACE CO.,LTD.

44 ซอยบรมราชชนนี 70 ถนนบรมราชชนนี แขวงศาลาธรรมสพน์ เขตทวีวัฒนา กรุงเทพฯ 10170

โทร: 02-888-3472 โทร: ออกแบบ:08-08-170-170 แฟกซ์: 02-888-3258

<https://www.add-furnace.com> E-mail: sales@add-furnace.com

Application

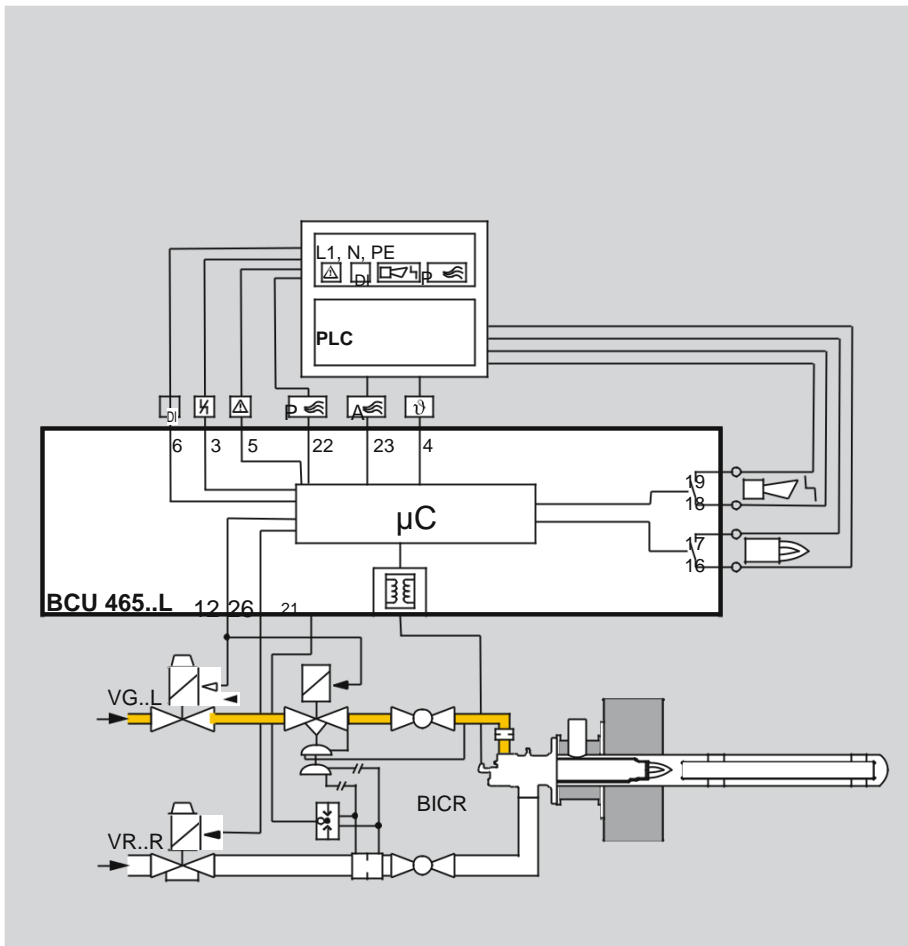

1.1.3 BCU 465..L: Single-stage-controlled burner with pneumatic air/gas ratio control system

Control: ON/OFF.

The BCU supports the cooling and purging processes. The variable air/gas ratio control compensates for gas/air pressure fluctuations. Optional: the pressure switch monitors the air flow during pre-purge and operation. The gas/air mixture is adjusted to the requirements of the applications using the differing parameters of pre- and post-ventilation.



บริษัท เอดีดี เฟอร์เนส จำกัด

ADD FURNACE CO.,LTD.

44 ซอยบรมราชชนนี 70 ถนนบรมราชชนนี แขวงศาลาธรรมสพน์ เขตทวีวัฒนา กรุงเทพฯ 10170

โทร: 02-888-3472 โทร: ออกแบบ:08-08-170-170 แฟกซ์: 02-888-3258

<https://www.add-furnace.com> E-mail: sales@add-furnace.com

Application

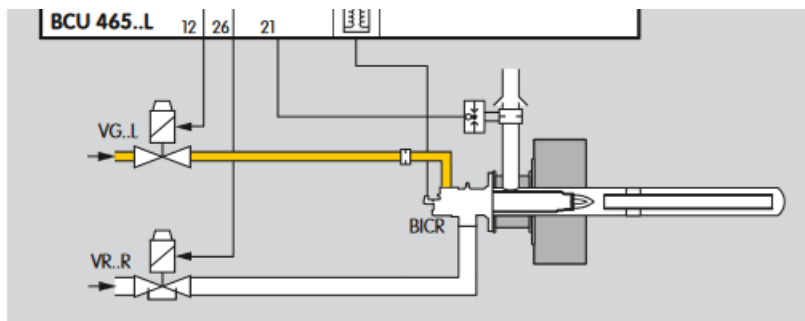
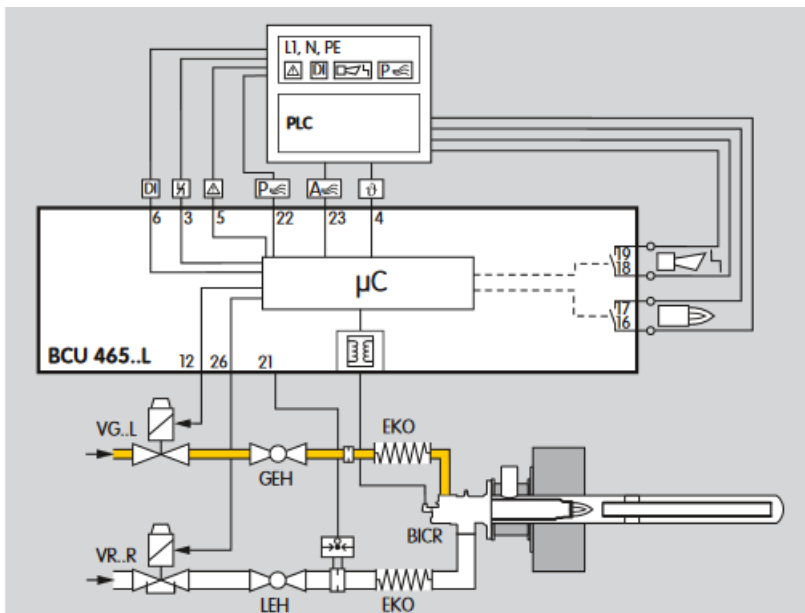

1.1.4 BCU 465 . .L: Single-stage-controlled burner

Control: ON/OFF.

The gas/air mixture is adjusted to the requirements of the applications using the differing parameters of pre- and post-ventilation. The pressure switch monitors the air flow in the air supply line or in the flue gas exhaust



บริษัท เอดีดี เฟอร์เนส จำกัด

ADD FURNACE CO.,LTD.

44 ซอยบรมราชชนนี 70 ถนนบรมราชชนนี แขวงศาลาธรรมสพน์ เขตทวีวัฒนา กรุงเทพฯ 10170

โทร: 02-888-3472 โทร: ออกแบบ:08-08-170-170 แฟกซ์: 02-888-3258

<https://www.add-furnace.com> E-mail: sales@add-furnace.com

Application

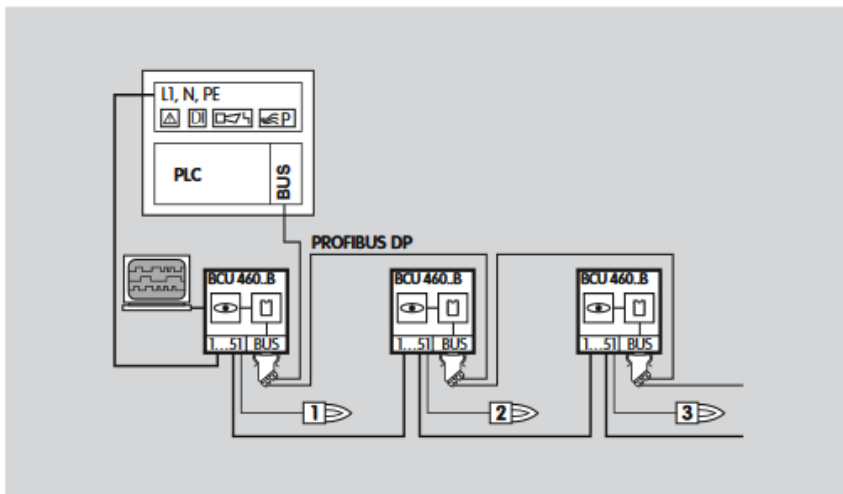

1.1.5 BCU 460..B1 for PROFIBUS DP The bus system transfers the control signals for starting, resetting and for controlling the air valve from the control system (PLC) to the BCU..B1. In the opposite direction it sends operating status, the level of the flame signal and the current program status.

Control signals that are relevant for safety, such as the safety interlocks and digital input, are transferred independently of the bus communication by separate cables.

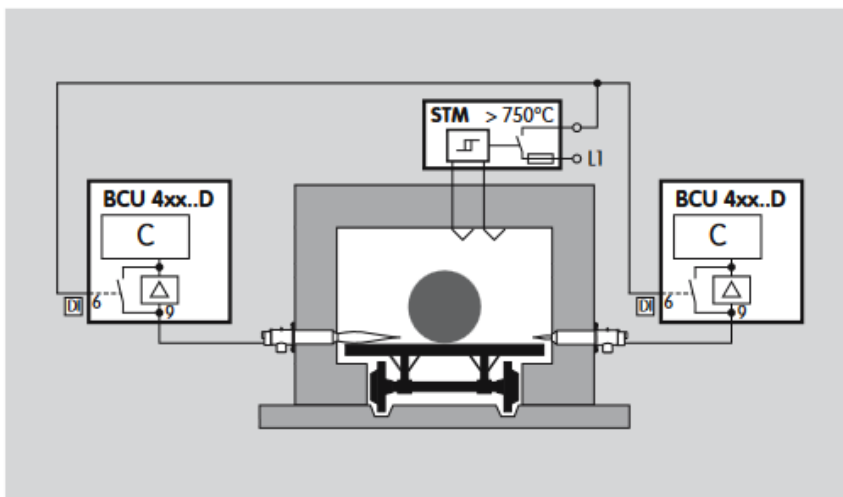

1.1.6 BCU 460..D: High temperature equipment

Indirect flame control using the temperature. During the start-up process, as long as the wall temperature is below auto ignition temperature, the flame must be controlled by conventional methods. When the working temperature has exceeded 750°C, the safety temperature monitor (STM) takes over the indirect flame control.



บริษัท เอดีดี เฟอร์เนส จำกัด

ADD FURNACE CO.,LTD.

44 ซอยบรมราชชนนี 70 ถนนบรมราชชนนี แขวงศาลาธรรมสพน์ เขตทวีวัฒนา กรุงเทพฯ 10170

โทร: 02-888-3472 โทร: ออกแบบ:08-08-170-170 แฟกซ์: 02-888-3258

<https://www.add-furnace.com> E-mail: sales@add-furnace.com

Certification

2 Certification

Certificates – see Docuthek.

Certified pursuant to SIL



For systems up to SIL 3 pursuant to EN 61508.

Pursuant to EN ISO 13849-1:2006, Table 4, the BCU can be used up to PL e.

EU certified pursuant to



– Gas Appliances Directive (2009/142/EC) in conjunction with EN 298:2012

Meets the requirements of the

- Low Voltage Directive (2006/95/EC),
- EMC Directive (2004/108/EC).

ANSI/CSA approved



American National Standards Institute/Canadian Standards Association – ANSI Z21.20/CSA C22.2, No. 199/UL 372

www.csagroup.org – Class number: 3335-01 and 3335-81.

FM approved



Factory Mutual Research Class: 7610 “Combustion Safeguards and Flame Sensing Systems”.

Suitable for applications pursuant to NFPA 86.

www.approvalguide.com

AGA approved



Australian Gas Association, Approval No.: 6478

http://www.aga.asn.au/product_directory

Eurasian Customs Union



The products BCU 460 and BCU 465 meet the technical specifications of the Eurasian Customs Union.



บริษัท เอดีดี เฟอร์เนส จำกัด

ADD FURNACE CO.,LTD.

44 ซอยบรมราชชนนี 70 ถนนบรมราชชนนี แขวงศาลาธรรมสพน์ เขตทวีวัฒนา กรุงเทพฯ 10170

โทร: 02-888-3472 โทร: ออกแบบ:08-08-170-170 แฟกซ์: 02-888-3258

https://www.add-furnace.com E-mail: sales@add-furnace.com

Function

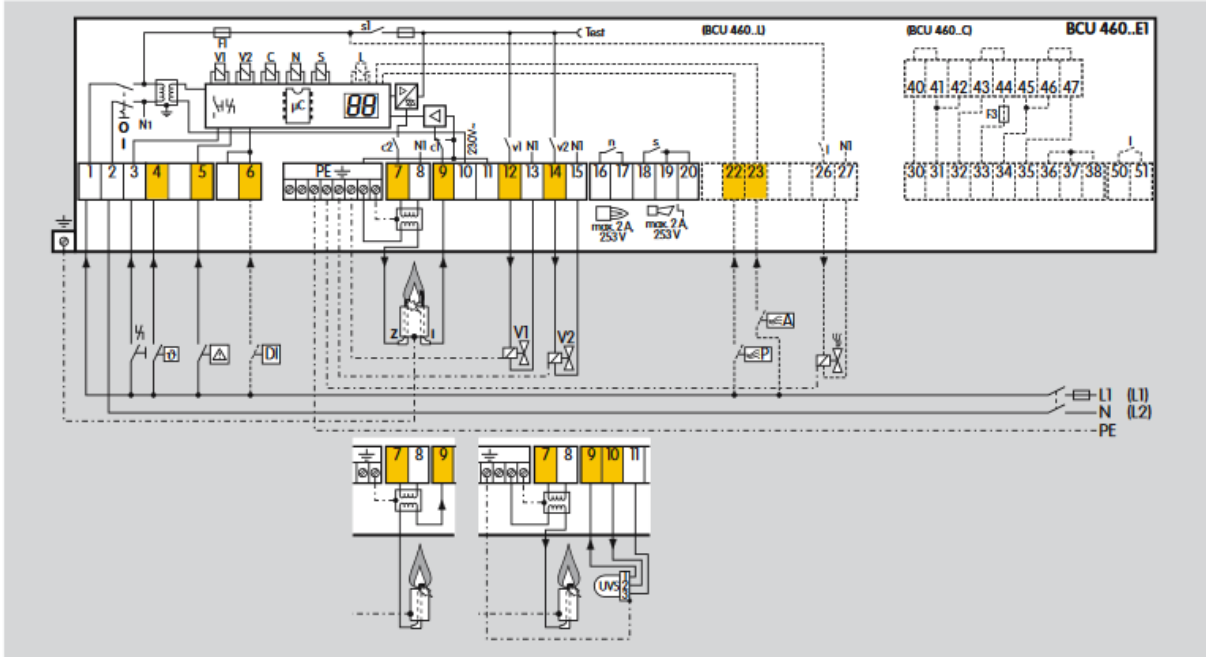

3 Function

3.1 Connection diagrams

3.1.1 BCU 460..E1

For cable selection and wiring, see page 67 (Project planning information).

For the explanation of symbols, see page 88 (Legend).



บริษัท เอดีดี เฟอร์เนส จำกัด

ADD FURNACE CO.,LTD.

44 ซอยบรมราชชนนี 70 ถนนบรมราชชนนี แขวงศาลาธรรมสพน์ เขตทวีวัฒนา กรุงเทพฯ 10170

โทร: 02-888-3472 โทร: ออกแบบ:08-08-170-170 แฟกซ์: 02-888-3258

<https://www.add-furnace.com> E-mail: sales@add-furnace.com

Function

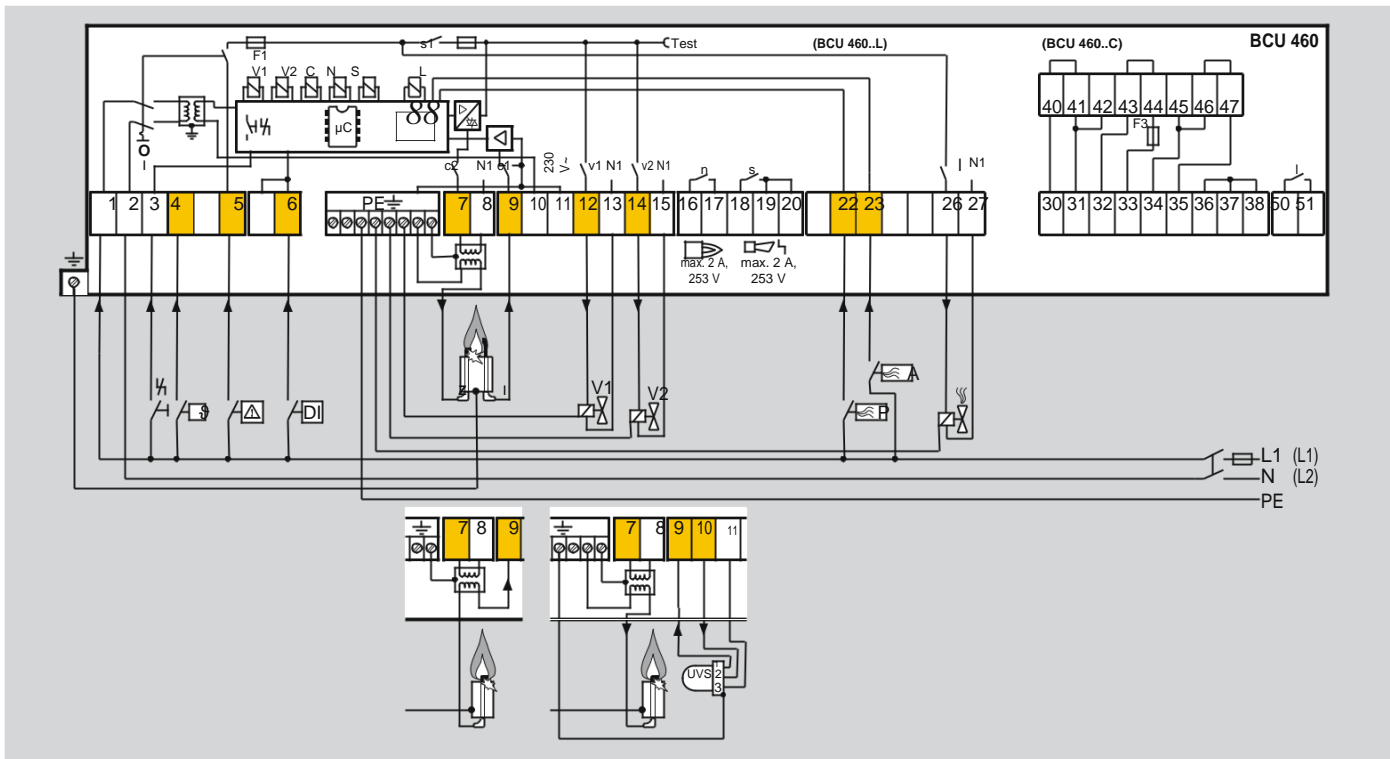

3.1.2 BCU 460

For cable selection and wiring, see page 67 (Project planning information).

For the explanation of symbols, see page 88 (Legend).



บริษัท เอดีดี เฟอร์เนส จำกัด

ADD FURNACE CO.,LTD.

44 ซอยบรมราชชนนี 70 ถนนบรมราชชนนี แขวงศาลาธรรมสพน์ เขตทวีวัฒนา กรุงเทพฯ 10170

โทร: 02-888-3472 โทร: ออกแบบ:08-08-170-170 แฟกซ์: 02-888-3258

<https://www.add-furnace.com> E-mail: sales@add-furnace.com

Function

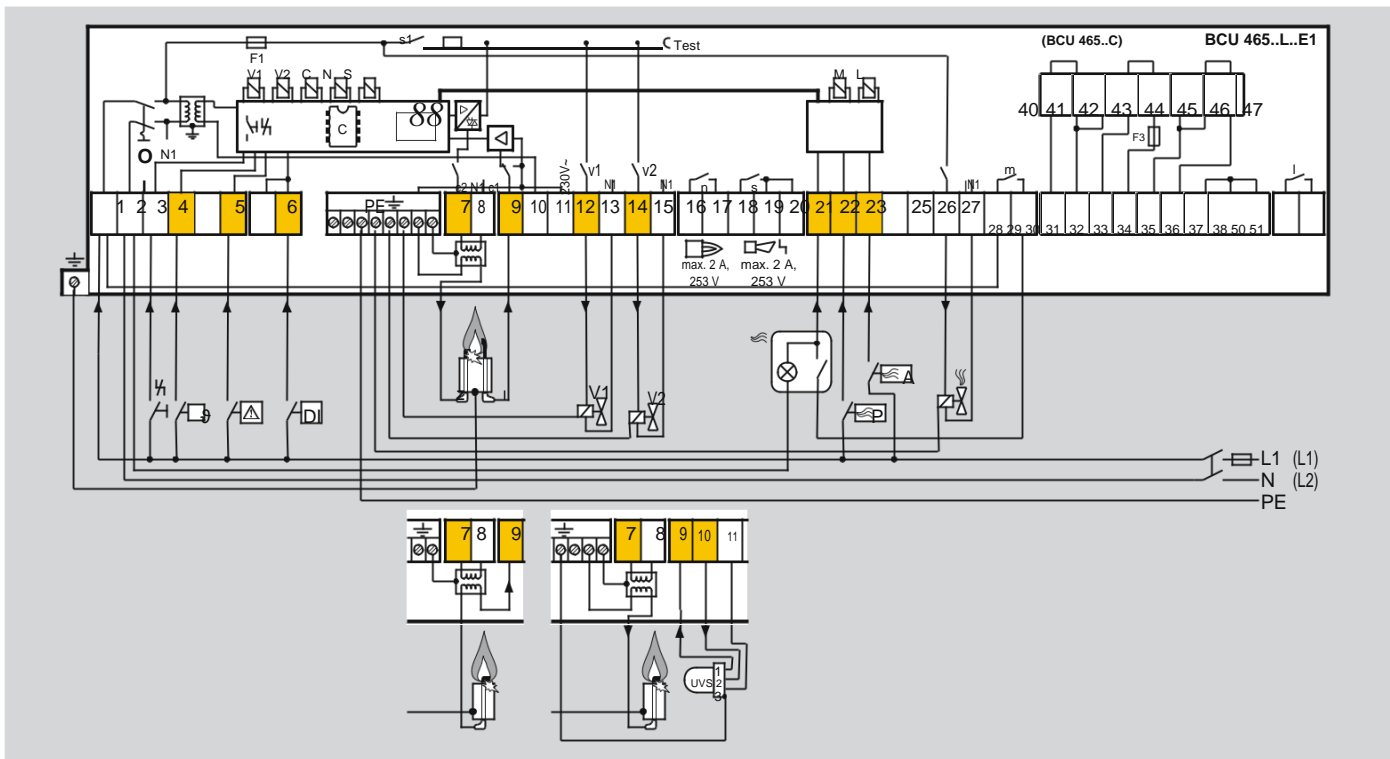

3.1.3 BCU 465..E1

For cable selection and wiring, see page 67 (Project planning information).

For the explanation of symbols, see page 88 (Legend).



บริษัท เอดีดี เฟอร์เนส จำกัด

ADD FURNACE CO.,LTD.

44 ซอยบรมราชชนนี 70 ถนนบรมราชชนนี แขวงศาลาธรรมสพน์ เขตทวีวัฒนา กรุงเทพฯ 10170

โทร: 02-888-3472 โทร: ออกแบบ:08-08-170-170 แฟกซ์: 02-888-3258

<https://www.add-furnace.com> E-mail: sales@add-furnace.com

Function

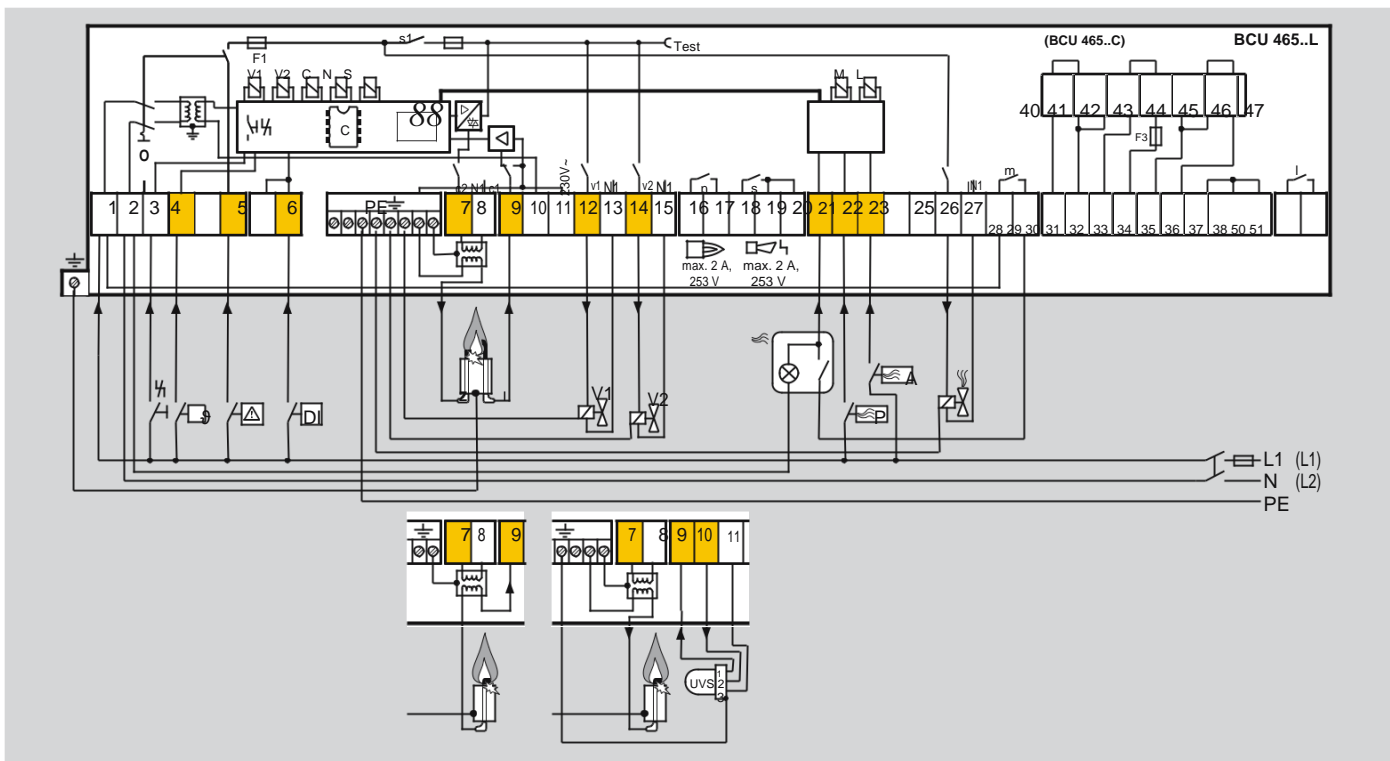

3.1.4 BCU 465

For cable selection and wiring, see page 67 (Project planning information).

For the explanation of symbols, see page 88 (Legend).



บริษัท เอดีดี เฟอร์เนส จำกัด

ADD FURNACE CO.,LTD.

44 ซอยบรมราชชนนี 70 ถนนบรมราชชนนี แขวงศาลาธรรมสพน์ เขตทวีวัฒนา กรุงเทพฯ 10170

โทร: 02-888-3472 โทร: ออกแบบ:08-08-170-170 แฟกซ์: 02-888-3258

<https://www.add-furnace.com> E-mail: sales@add-furnace.com

Function

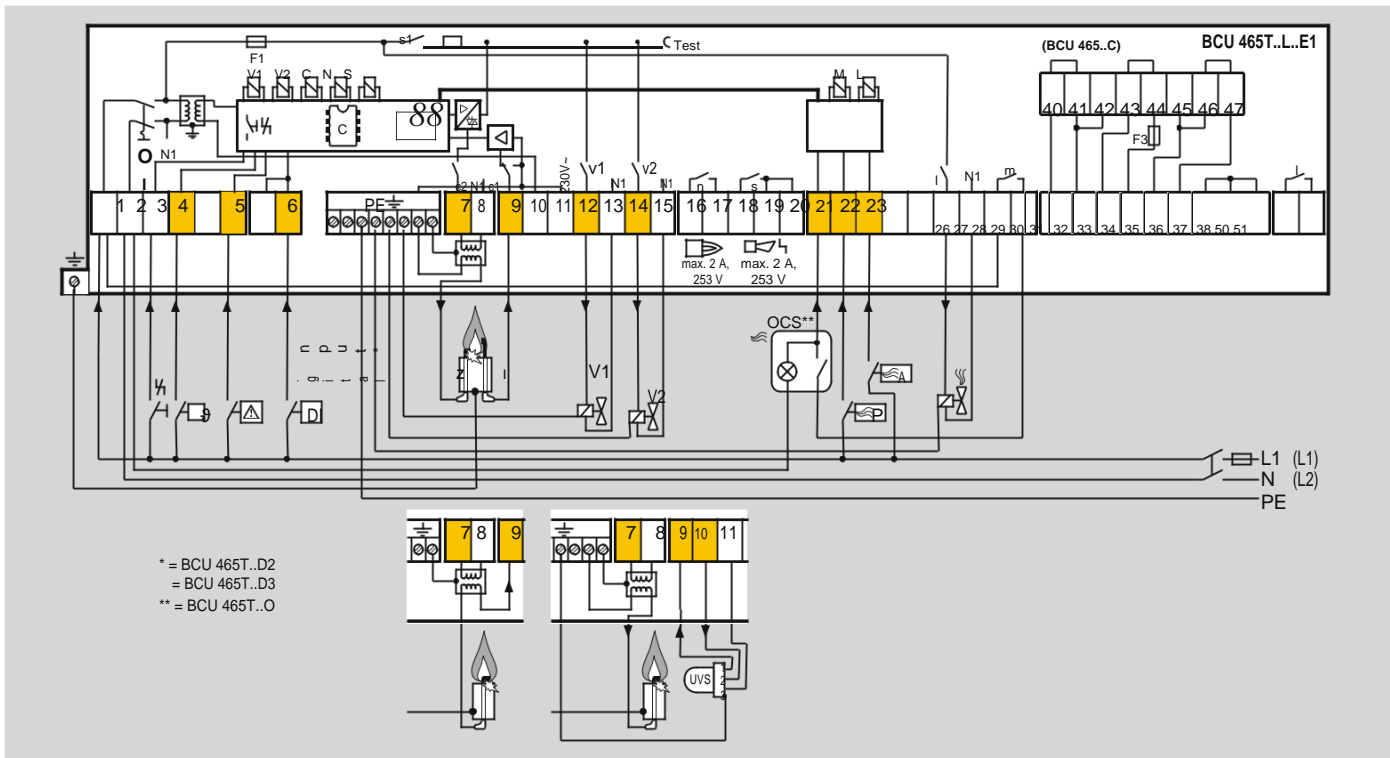

3.1.5 BCU 465T..E1

For cable selection and wiring, see page 67 (Project planning information).

For the explanation of symbols, see page 88 (Legend).



บริษัท เอดีดี เฟอร์เนส จำกัด

ADD FURNACE CO.,LTD.

44 ซอยบรมราชชนนี 70 ถนนบรมราชชนนี แขวงศาลาธรรมสพน์ เขตทวีวัฒนา กรุงเทพฯ 10170

โทร: 02-888-3472 โทร: ออกแบบ:08-08-170-170 แฟกซ์: 02-888-3258

<https://www.add-furnace.com> E-mail: sales@add-furnace.com

Function

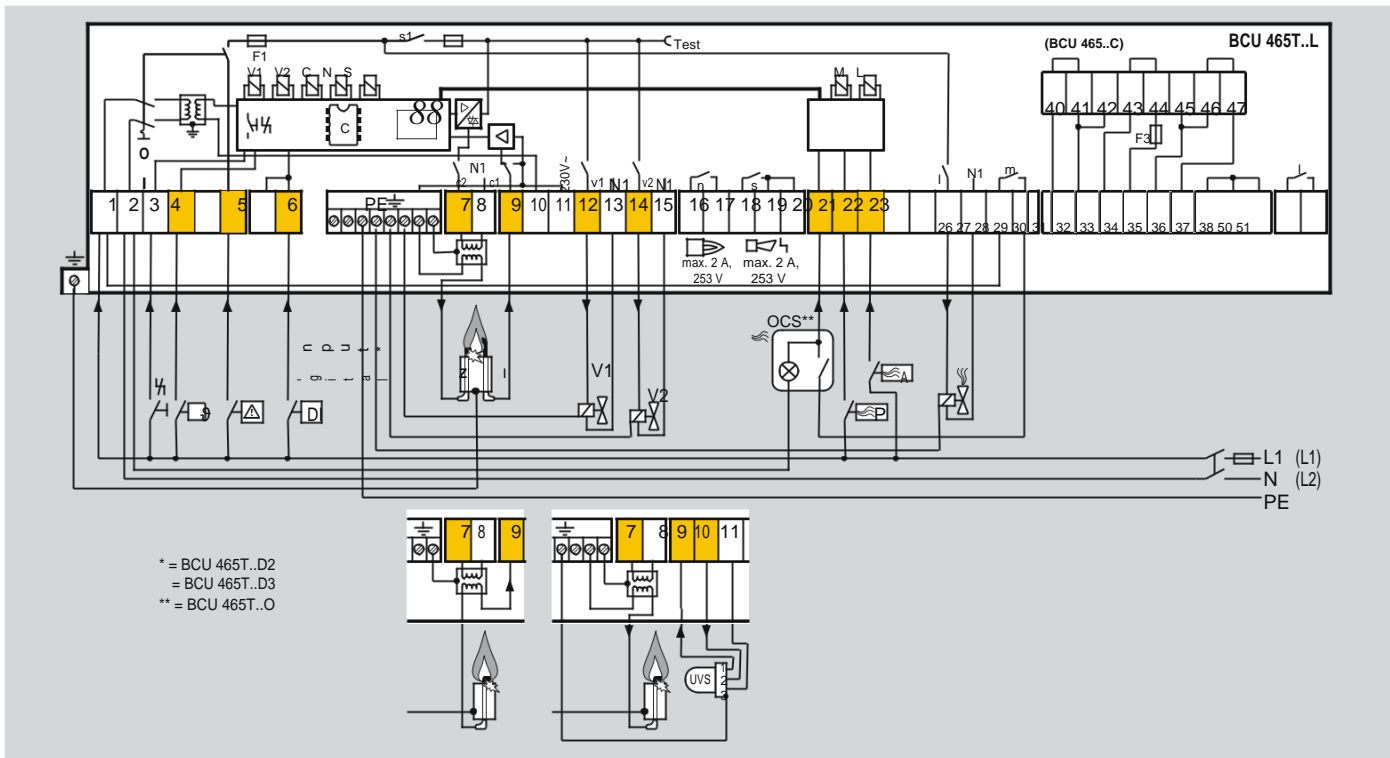

3.1.6 BCU 465T

For cable selection and wiring, see page 67 (Project planning information).

For the explanation of symbols, see page 88 (Legend).



บริษัท เอดีดี เฟอร์เนส จำกัด

ADD FURNACE CO.,LTD.

44 ซอยบรมราชชนนี 70 ถนนบรมราชชนนี แขวงศาลาธรรมสพน์ เขตทวีวัฒนา กรุงเทพฯ 10170

โทร: 02-888-3472 โทร: ออกแบบ:08-08-170-170 แฟกซ์: 02-888-3258

https://www.add-furnace.com E-mail: sales@add-furnace.com

Function

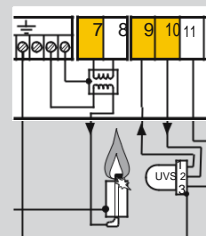
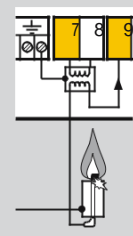
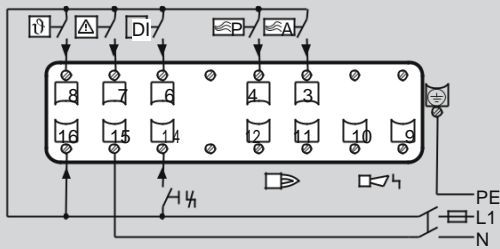
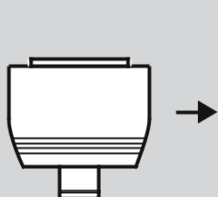
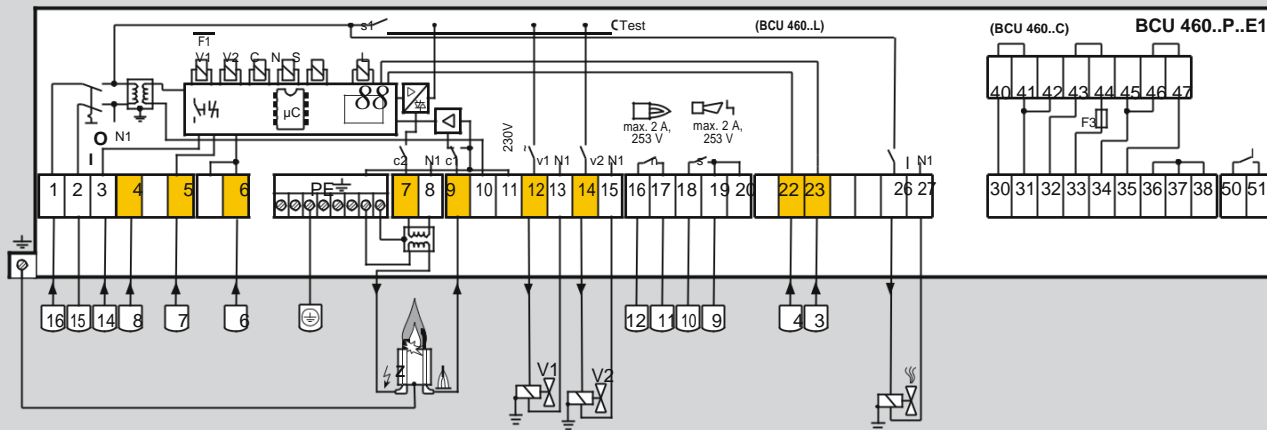

3.1.7 BCU 460..P..E1 with industrial plug connector

For cable selection and wiring, see page 67 (Project planning information).

For the explanation of symbols, see page 88 (Leg-end).



บริษัท เอดีดี เฟอร์เนส จำกัด

ADD FURNACE CO.,LTD.

44 ซอยบรมราชชนนี 70 ถนนบรมราชชนนี แขวงศาลาธรรมสพน์ เขตทวีวัฒนา กรุงเทพฯ 10170

โทร: 02-888-3472 โทร: ออกแบบ:08-08-170-170 แฟกซ์: 02-888-3258

https://www.add-furnace.com E-mail: sales@add-furnace.com

Function

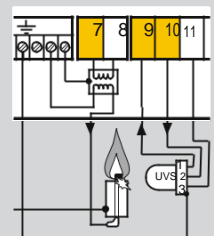
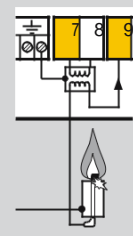
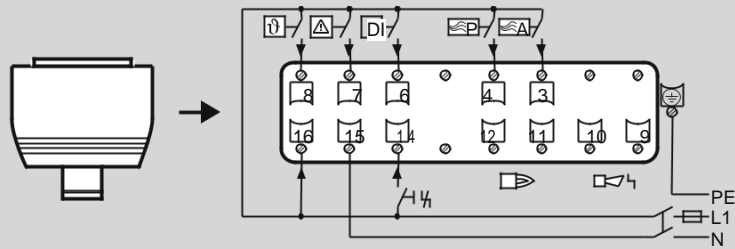
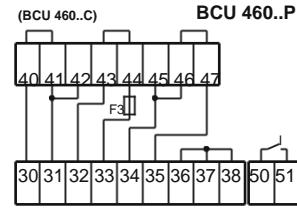
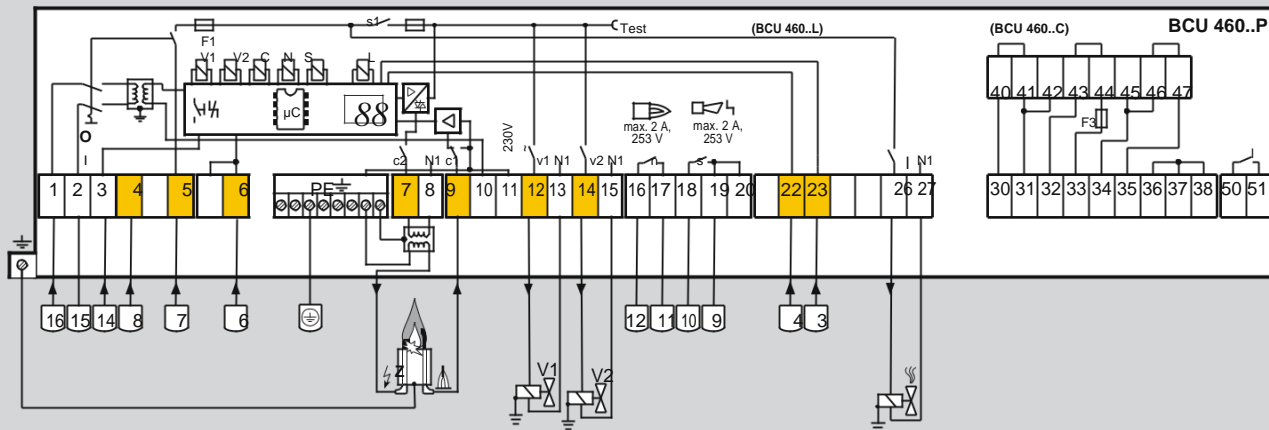

3.1.8 BCU 460..P with industrial plug connector

For cable selection and wiring, see page 67 (Project planning information).

For the explanation of symbols, see page 88 (Leg-end).



บริษัท เอดีดี เฟอร์เนส จำกัด

ADD FURNACE CO.,LTD.

44 ซอยบรมราชชนนี 70 ถนนบรมราชชนนี แขวงศาลาธรรมสพน์ เขตทวีวัฒนา กรุงเทพฯ 10170

โทร: 02-888-3472 โทร: ออกแบบ:08-08-170-170 แฟกซ์: 02-888-3258

https://www.add-furnace.com E-mail: sales@add-furnace.com

Function

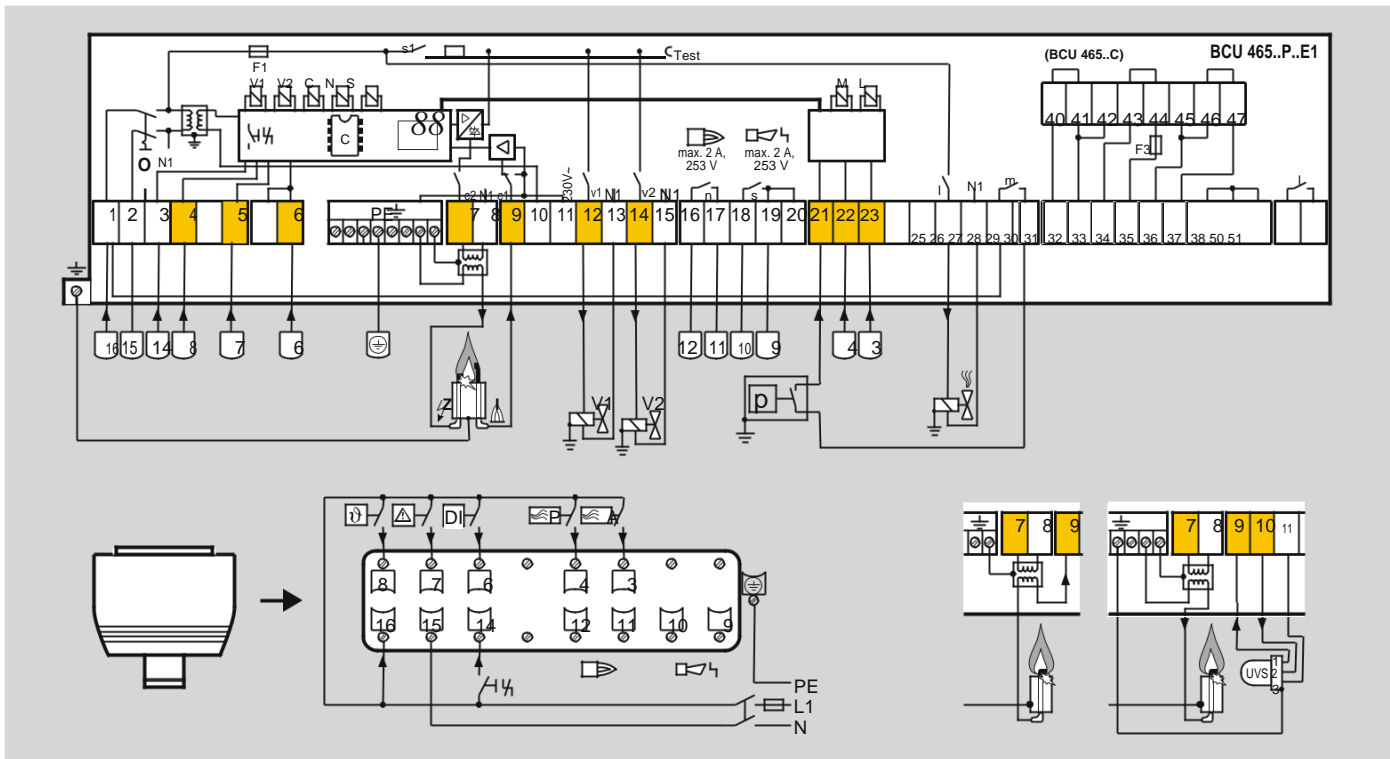

3.1.9 BCU 465..P..E1 with industrial plug connector

For cable selection and wiring, see page 67 (Project planning information).

For the explanation of symbols, see page 88 (Legend).



บริษัท เอดีดี เฟอร์เนส จำกัด

ADD FURNACE CO.,LTD.

44 ซอยบรมราชชนนี 70 ถนนบรมราชชนนี แขวงศาลาธรรมสพน์ เขตทวีวัฒนา กรุงเทพฯ 10170

โทร: 02-888-3472 โทร: ออกแบบ:08-08-170-170 แฟกซ์: 02-888-3258

https://www.add-furnace.com E-mail: sales@add-furnace.com

Function

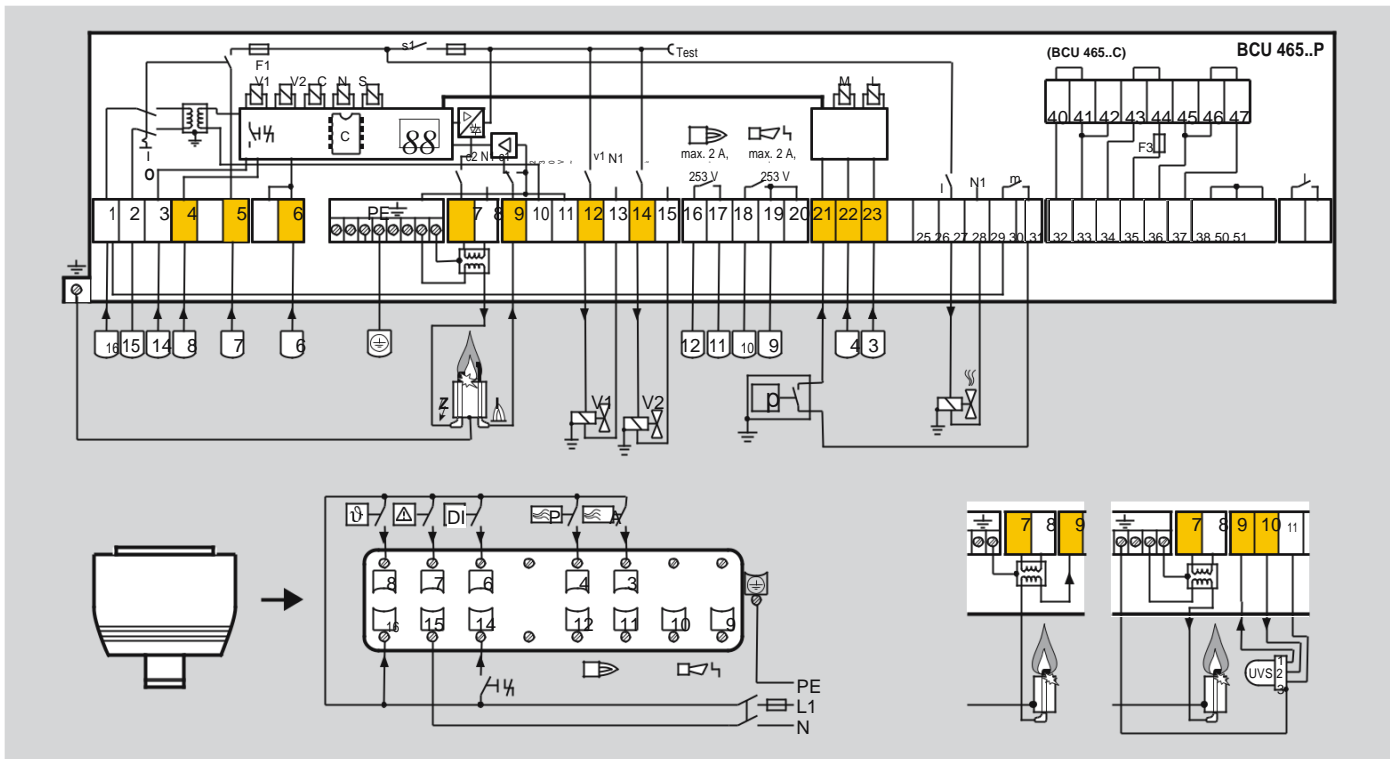

3.1.10 BCU 465..P with industrial plug connector

For cable selection and wiring, see page 67 (Project planning information).

For the explanation of symbols, see page 88 (Legend).



บริษัท เอดีดี เฟอร์เนส จำกัด

ADD FURNACE CO.,LTD.

44 ซอยบรมราชชนนี 70 ถนนบรมราชชนนี แขวงศาลาธรรมสพน์ เขตทวีวัฒนา กรุงเทพฯ 10170

โทร: 02-888-3472 โทร: ออกแบบ:08-08-170-170 แฟกซ์: 02-888-3258

https://www.add-furnace.com E-mail: sales@add-furnace.com

Function

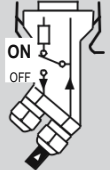
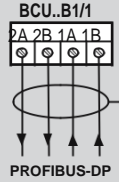
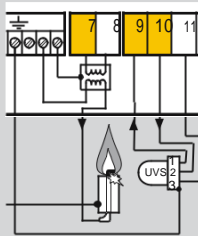
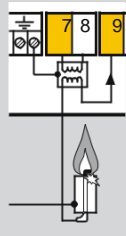
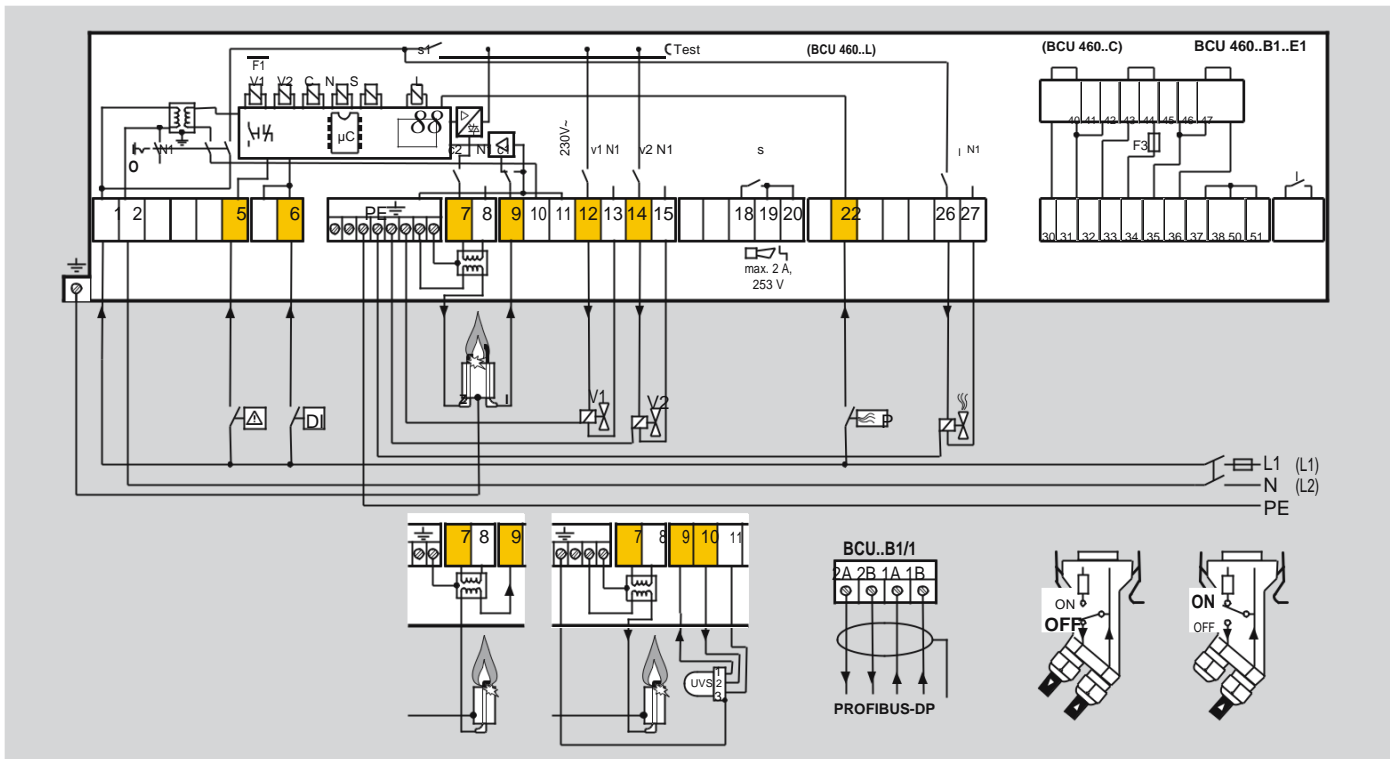

3.1.11 BCU 460..B1..E1

For cable selection and wiring, see page 67 (Project planning information).

For the explanation of symbols, see page 88 (Leg-end).



บริษัท เอดีดี เฟอร์เนส จำกัด

ADD FURNACE CO.,LTD.

44 ซอยบรมราชชนนี 70 ถนนบรมราชชนนี แขวงศาลาธรรมสพน์ เขตทวีวัฒนา กรุงเทพฯ 10170

โทร: 02-888-3472 โทร: ออกแบบ:08-08-170-170 แฟกซ์: 02-888-3258

<https://www.add-furnace.com> E-mail: sales@add-furnace.com

Function

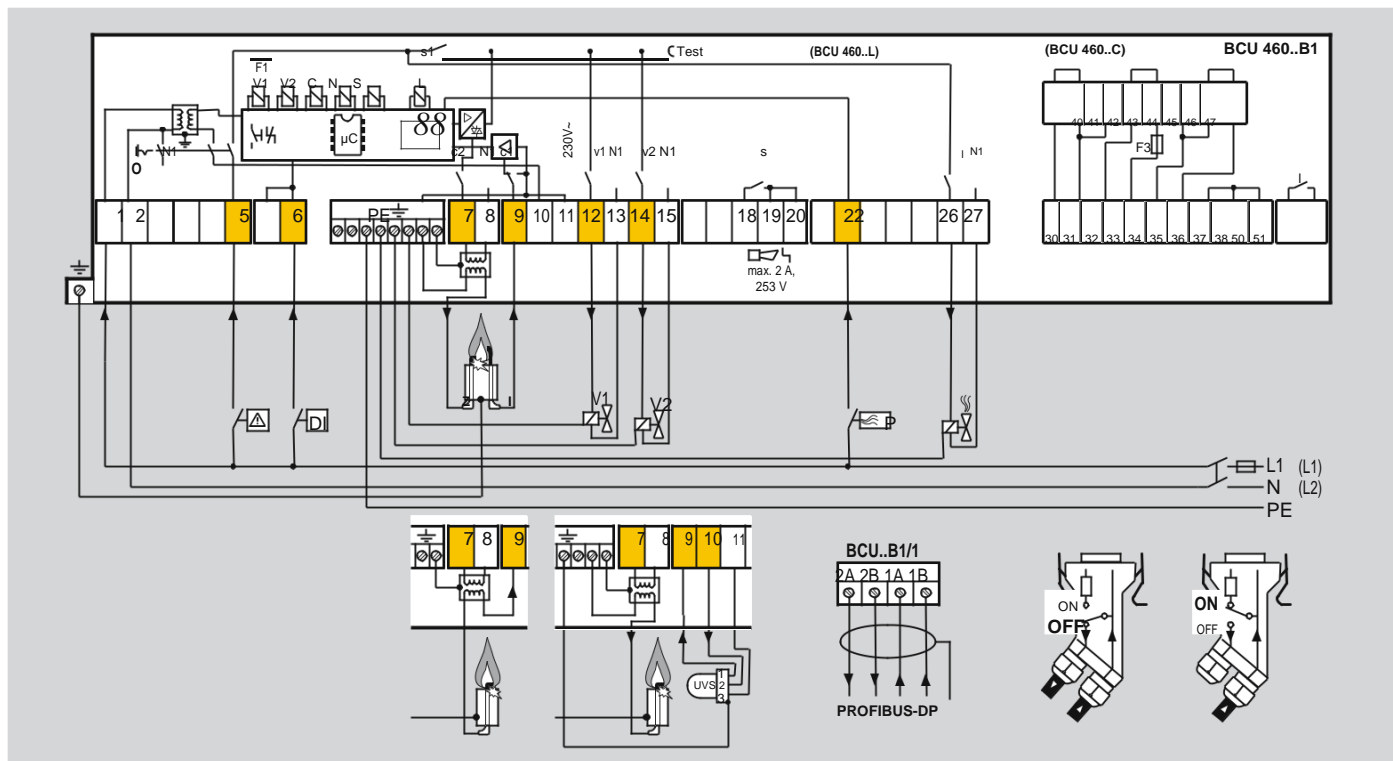

3.1.12 BCU 460..B1

For cable selection and wiring, see page 67 (Project planning information).

For the explanation of symbols, see page 88 (Leg-end).



บริษัท เอดีดี เฟอร์เนส จำกัด

ADD FURNACE CO.,LTD.

44 ซอยบรมราชชนนี 70 ถนนบรมราชชนนี แขวงศาลาธรรมสพน์ เขตทวีวัฒนา กรุงเทพฯ 10170

โทร: 02-888-3472 โทร: ออกแบบ:08-08-170-170 แฟกซ์: 02-888-3258

<https://www.add-furnace.com> E-mail: sales@add-furnace.com

Function

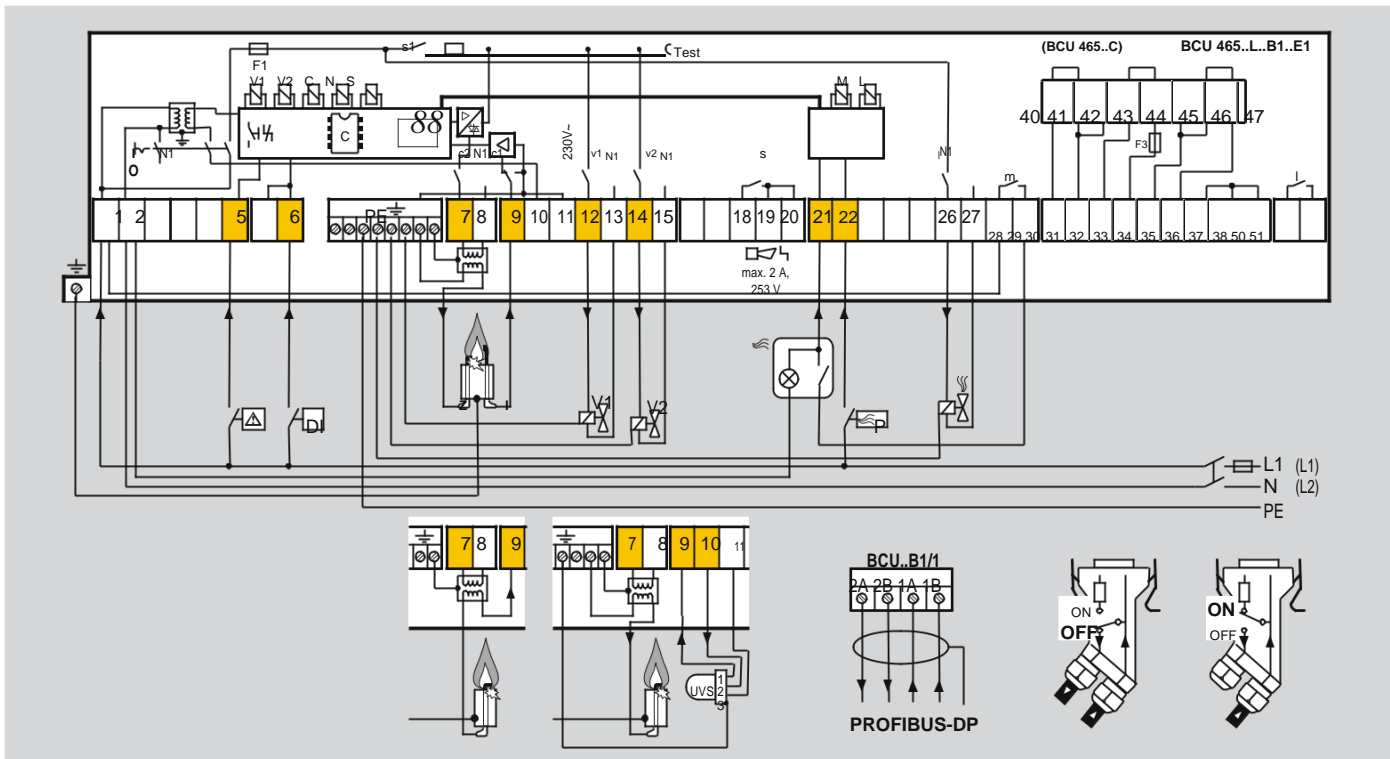

3.1.13 BCU 465..B1..E1

For cable selection and wiring, see page 67 (Project planning information).

For the explanation of symbols, see page 88 (Legend).



บริษัท เอดีดี เฟอร์เนส จำกัด

ADD FURNACE CO.,LTD.

44 ซอยบรมราชชนนี 70 ถนนบรมราชชนนี แขวงศาลาธรรมสพน์ เขตทวีวัฒนา กรุงเทพฯ 10170

โทร: 02-888-3472 โทร: ออกแบบ:08-08-170-170 แฟกซ์: 02-888-3258

https://www.add-furnace.com E-mail: sales@add-furnace.com

Function

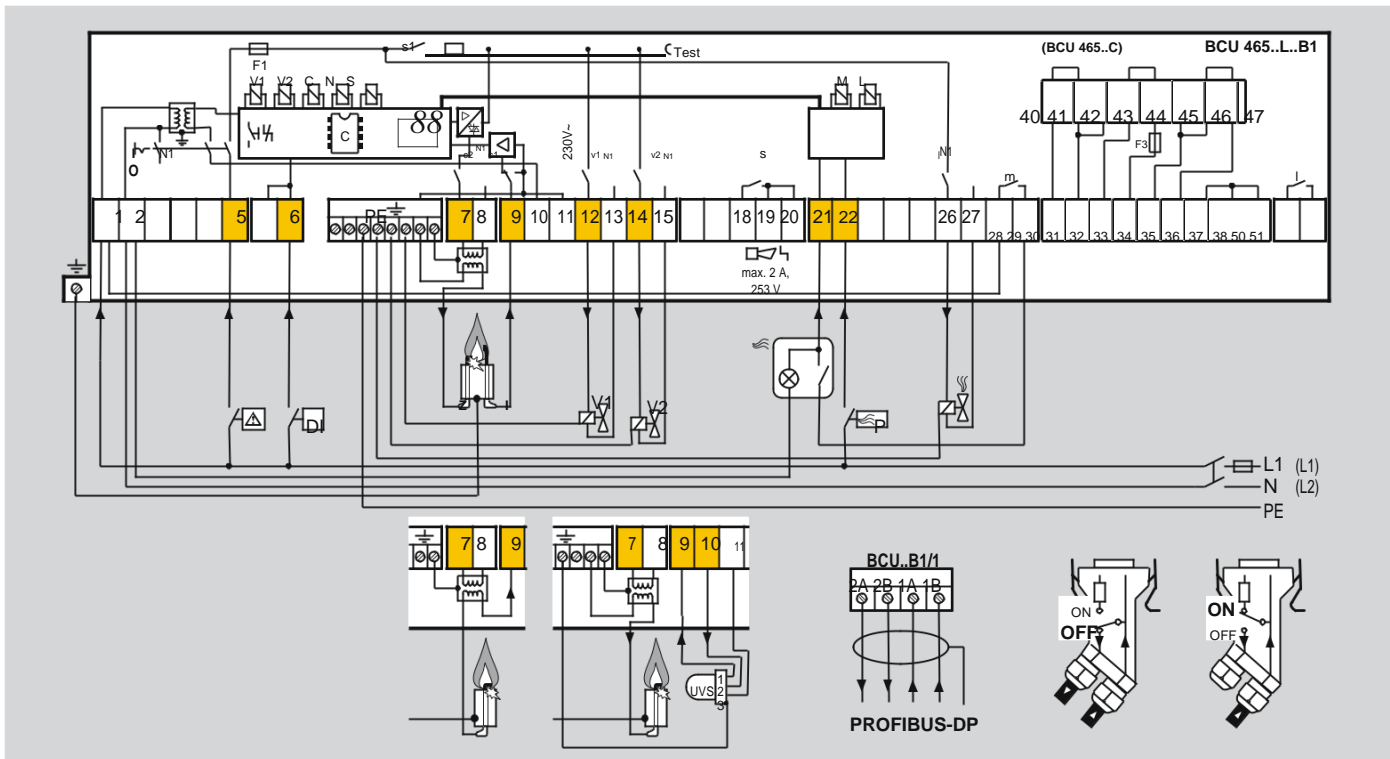

3.1.14 BCU 465..B1

For cable selection and wiring, see page 67 (Project planning information).

For the explanation of symbols, see page 88 (Legend).



บริษัท เอดีดี เฟอร์เนส จำกัด

ADD FURNACE CO.,LTD.

44 ซอยบรมราชชนนี 70 ถนนบรมราชชนนี แขวงศาลาธรรมสพน์ เขตทวีวัฒนา กรุงเทพฯ 10170

โทร: 02-888-3472 โทร: ออกแบบ:08-08-170-170 แฟกซ์: 02-888-3258

https://www.add-furnace.com E-mail: sales@add-furnace.com

Function

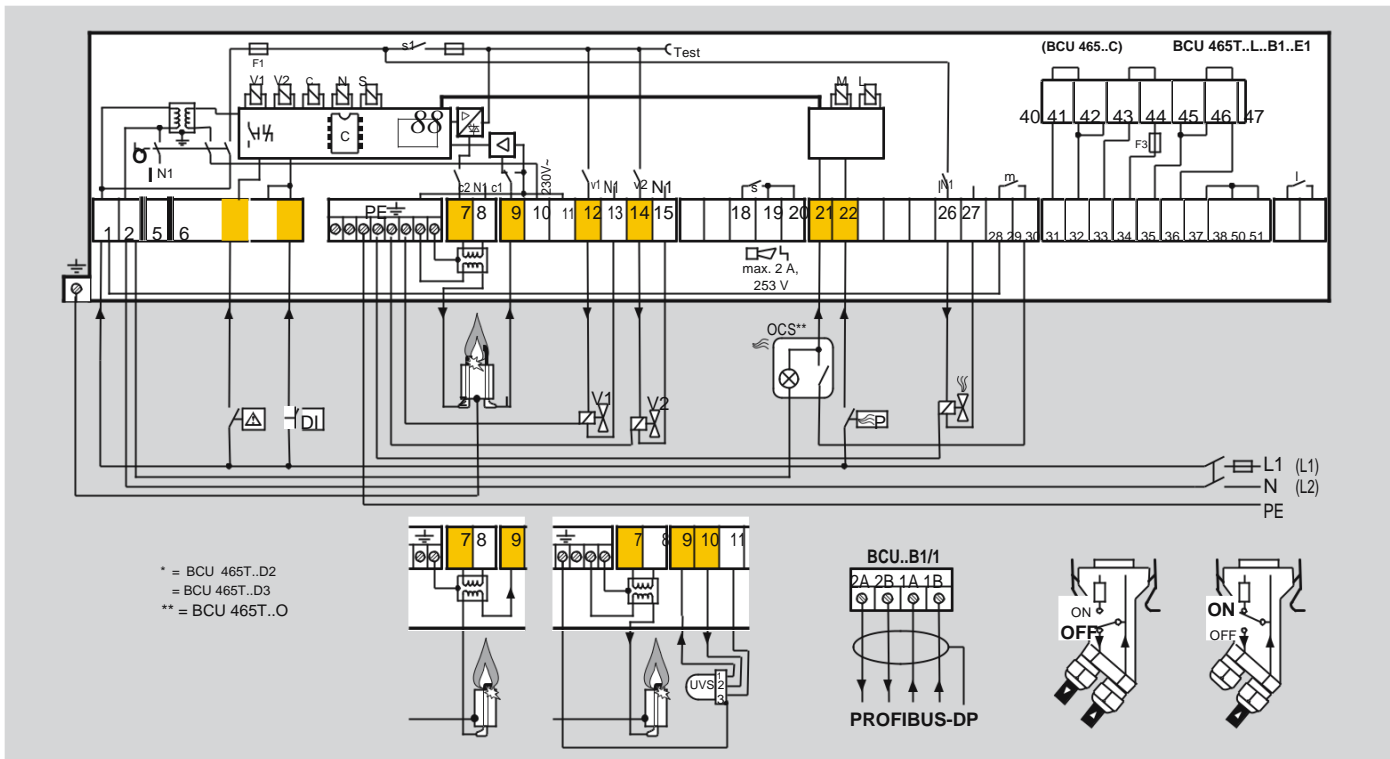

3.1.15 BCU 465T..B1..E1

For cable selection and wiring, see page 67 (Project planning information).

For the explanation of symbols, see page 88 (Legend).



บริษัท เอดีดี เฟอร์เนส จำกัด

ADD FURNACE CO.,LTD.

44 ซอยบรมราชชนนี 70 ถนนบรมราชชนนี แขวงศาลาธรรมสพน์ เขตทวีวัฒนา กรุงเทพฯ 10170

โทร: 02-888-3472 โทร: ออกแบบ:08-08-170-170 แฟกซ์: 02-888-3258

<https://www.add-furnace.com> E-mail: sales@add-furnace.com

Function

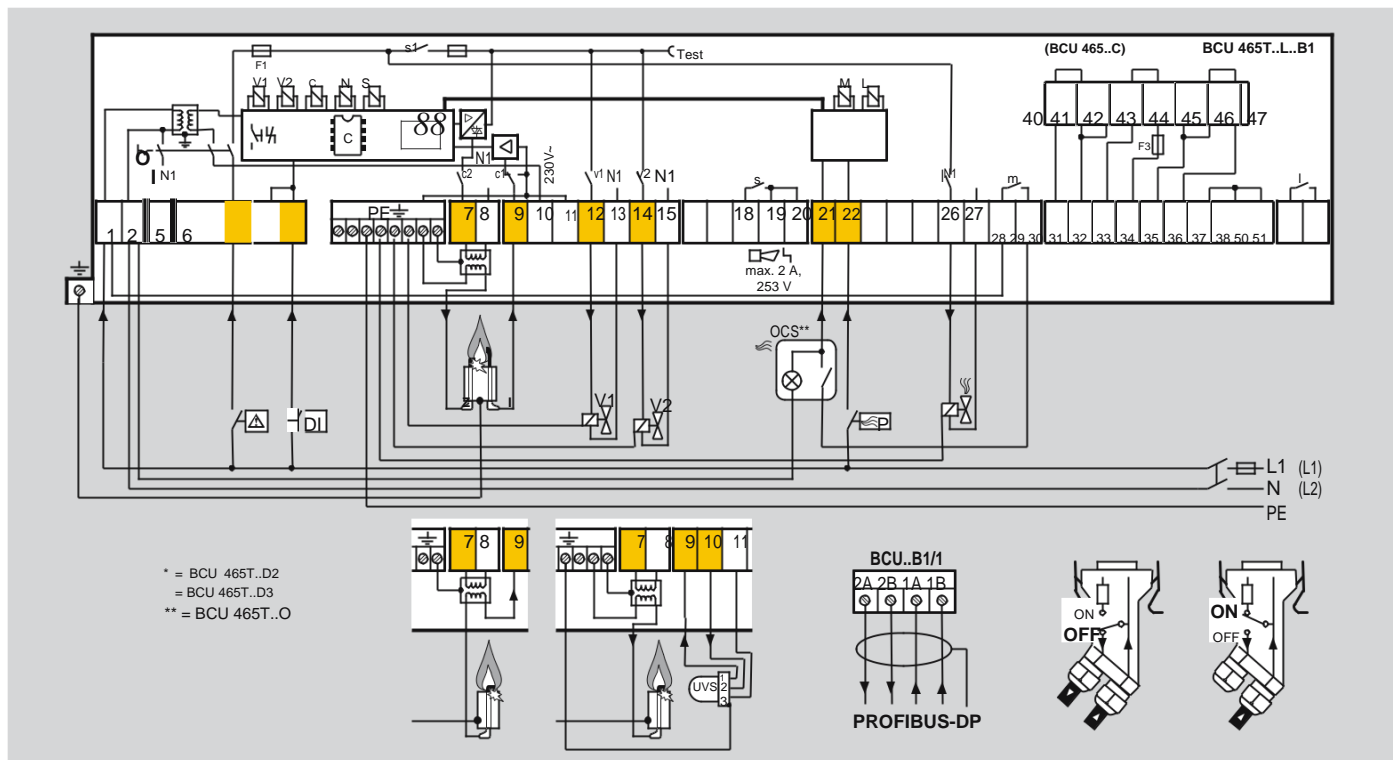

* = BCU 465T..D2
= BCU 465T..D3
** = BCU 465T..O

3.1.16 BCU 465T..B1

For cable selection and wiring, see page 67 (Project planning information).

For the explanation of symbols, see page 88 (Legend).



บริษัท เอดีดี เฟอร์เนส จำกัด

ADD FURNACE CO.,LTD.

44 ซอยบรมราชชนนี 70 ถนนบรมราชชนนี แขวงศาลาธรรมสพน์ เขตทวีวัฒนา กรุงเทพฯ 10170

โทร: 02-888-3472 โทร: ออกแบบ:08-08-170-170 แฟกซ์: 02-888-3258

<https://www.add-furnace.com> E-mail: sales@add-furnace.com

Function



3.2 BCU..P with 16-pin industrial plug connector

The burner control units BCU 460..P and BCU 465..P can be supplied with an industrial plug connector (pur-suant to VDE 0627). This 16-pin plug connector en-sures fast connecting or disconnecting of units without any additional wiring required. This simplifies replacing units and reduces standstill times.

All signals to the higher-level control system, the mains supply and the safety interlocks are routed via this plug, see page 81 (Accessories).





บริษัท เอดีดี เฟอร์เนส จำกัด

ADD FURNACE CO.,LTD.

44 ซอยบรมราชชนนี 70 ถนนบรมราชชนนี แขวงศาลาธรรมสพน์ เขตทวีวัฒนา กรุงเทพฯ 10170

โทร: 02-888-3472 โทร: ออกแบบ:08-08-170-170 แฟกซ์: 02-888-3258

https://www.add-furnace.com E-mail: sales@add-furnace.com

Function

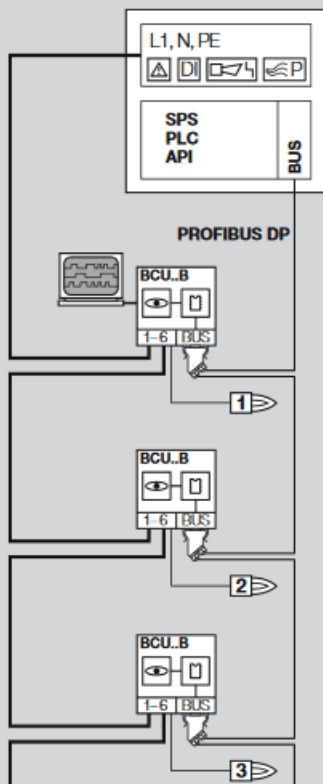

3.3 PROFIBUS DP

BCU..B1 features the same scope of functions and performance of a BCU® without a PROFIBUS connection.

PROFIBUS is a manufacturer-independent, open field-bus standard for diverse applications.

PROFIBUS DP is a bus variant for communication between automation systems and distributed peripherals at the field level, optimized for speed and low connection costs.

On PROFIBUS DP, the individual bus stations are connected via a 2-core shielded cable as standard.

The bus system transfers the control signals for start-ing, resetting and for controlling the air valve to purge the furnace or kiln or for cooling in start-up position and heating during operation from the control system (PLC) to the BCU..B1. In the opposite direction, it sends operating status, the level of the flame signal and the current program status.

3.3.1 Safety-related control signals

Signals from the safety interlocks and digital input are transferred independently of the bus communication by separate cables. The air valve used to purge the furnace or kiln can either be activated via the PROFIBUS or via a separate cable to terminal 22. The purging process must be monitored by further measures, e.g. flow monitoring.



บริษัท เอดีดี เฟอร์เนส จำกัด

ADD FURNACE CO.,LTD.

44 ซอยบรมราชชนนี 70 ถนนบรมราชชนนี แขวงศาลาธรรมสพน์ เขตทวีวัฒนา กรุงเทพฯ 10170

โทร: 02-888-3472 โทร: ออกแบบ:08-08-170-170 แฟกซ์: 02-888-3258

<https://www.add-furnace.com> E-mail: sales@add-furnace.com

Function

3.3.2BCSoft

The Windows software BCSoft allows extended access to individual statistics, protocol functions, line recorders and the parameterization of the burner control unit via an optical interface. Unit parameters which are not relevant to safety can be set and adjusted to the specific application.

3.3.3 Configuration, Master-Slave procedure

PROFIBUS DP is structured as a Master-Slave system. This allows mono-master or multi-master systems to be implemented.

A distinction is made between three device types:

–DP Masters Class 1 (DPM1)

DPM1 devices are central controllers which exchange data with the distributed stations (slaves) on the basis of a defined cycle. This includes, for instance, the PLC, PC, CNC or VME systems with which the PROFIBUS DP is operated.

–DP Masters Class 2 (DPM2)

DPM2 devices are programming, project planning or Operator-control devices. They are used for configuration and commissioning of the system or for system operation and visualization in ongoing operation.

–DP Slaves

The devices which transmit input information from the periphery to the master and which issue output

information from the master to the periphery are referred to as “slaves”.This also includes the BCU..B1.

3.3.4 Addressing

A maximum of 126 units (masters and slaves) can be connected to a PROFIBUS DP system. Each station is assigned an individual PROFIBUS address which can be set between 0 and 126 using two code switches on the BCU..B1 board.

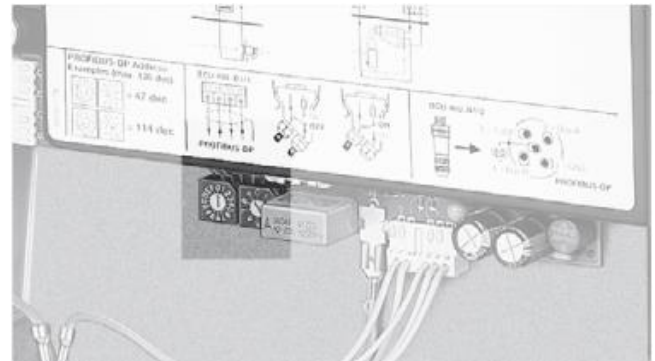



บริษัท เอดีดี เฟอร์เนส จำกัด

ADD FURNACE CO.,LTD.

44 ซอยบรมราชชนนี 70 ถนนบรมราชชนนี แขวงศาลาธรรมสพน์ เขตทวีวัฒนา กรุงเทพฯ 10170

โทร: 02-888-3472 โทร: ออกแบบ:08-08-170-170 แฟกซ์: 02-888-3258

<https://www.add-furnace.com> E-mail: sales@add-furnace.com

Function

3.3.5 Network technology

All devices are connected in a bus structure (line). Up to 32 stations (masters or slaves) can be connected in a single segment. The beginning and end of each segment is fitted with an active bus terminator. Both bus terminators must have a permanent power supply to ensure error-free operation. The power supply for the bus terminator is provided by the BCU. The bus terminator can be connected in the bus connection plug.

If more than 32 stations are implemented or if there is a need to expand the network area, repeaters (amplifiers) must be used to link the individual bus segments.

3.3.6 Configuration

When planning a PROFIBUS DP system, unit-specific parameters of each station are to be taken into account.

To allow for simple and standardized planning, the parameters of the BCU..B1 have been summarized in a so-called device master data file (GSD). The file structure is standardized so that it can be read by the planning devices of different manufacturers.

The GSD file is supplied on the BCSoft CD which is included in the delivery of BCU..B1. The GSD file can also be ordered at www.docuthek.com. The steps required to copy the file are described in the instructions for the automation system.

3.3.7 Bus communication

Input bytes (BCU master)		Byte 1	Byte 2	Byte 3	Byte 4
Bit	Byte 0				
0		Reserved	fault	39	Reserved
1	Reserved				
2					
3					
4					
5					
6					
7					
BCU 460/465 basic I/O					
BCU 460/465 standard I/O					

Output bytes (master BCU)	
Bit	Byte 0
0	
1	
2	
3	
4	Reserved
5	Reserved
6	Reserved
7	Reserved



บริษัท เอดีดี เฟอร์เนส จำกัด

ADD FURNACE CO.,LTD.

44 ซอยบรมราชชนนี 70 ถนนบรมราชชนนี แขวงศาลาธรรมสพน์ เขตทวีวัฒนา กรุงเทพฯ 10170

โทร: 02-888-3472 โทร: ออกแบบ:08-08-170-170 แฟกซ์: 02-888-3258

<https://www.add-furnace.com> E-mail: sales@add-furnace.com

Function

I/O bytes: the programmer can choose the data to be transferred.

	Inputs	Outputs
460/465 basic I/O	1 byte	1 byte
460/465 standard I/O	4 bytes	1 byte
480 basic I/O	1 byte	1 byte
480 standard I/O	5 bytes	1 byte

Baud rate: up to 1500 kbit/s.

The max. range per segment depends on the baud rate:

Baud rate [kbit/s]	Range [m]
93.75	1200
187.5	1000
500	400
1500	200

The specified ranges may be increased by using repeaters. No more than three repeaters should be connected in series.

The specified ranges relate to bus cable type A (two-core, shielded and twisted), e.g.

Siemens, Order No.: 6XV1830-0EH10, or

Lapp cable unitronic, Order No.: 2170-220T.



บริษัท เอดีดี เฟอร์เนส จำกัด

ADD FURNACE CO.,LTD.

44 ซอยบรมราชชนนี 70 ถนนบรมราชชนนี แขวงศาลาธรรมสพน์ เขตทวีวัฒนา กรุงเทพฯ 10170

โทร: 02-888-3472 โทร: ออกแบบ:08-08-170-170 แฟกซ์: 02-888-3258

https://www.add-furnace.com E-mail: sales@add-furnace.com

Function

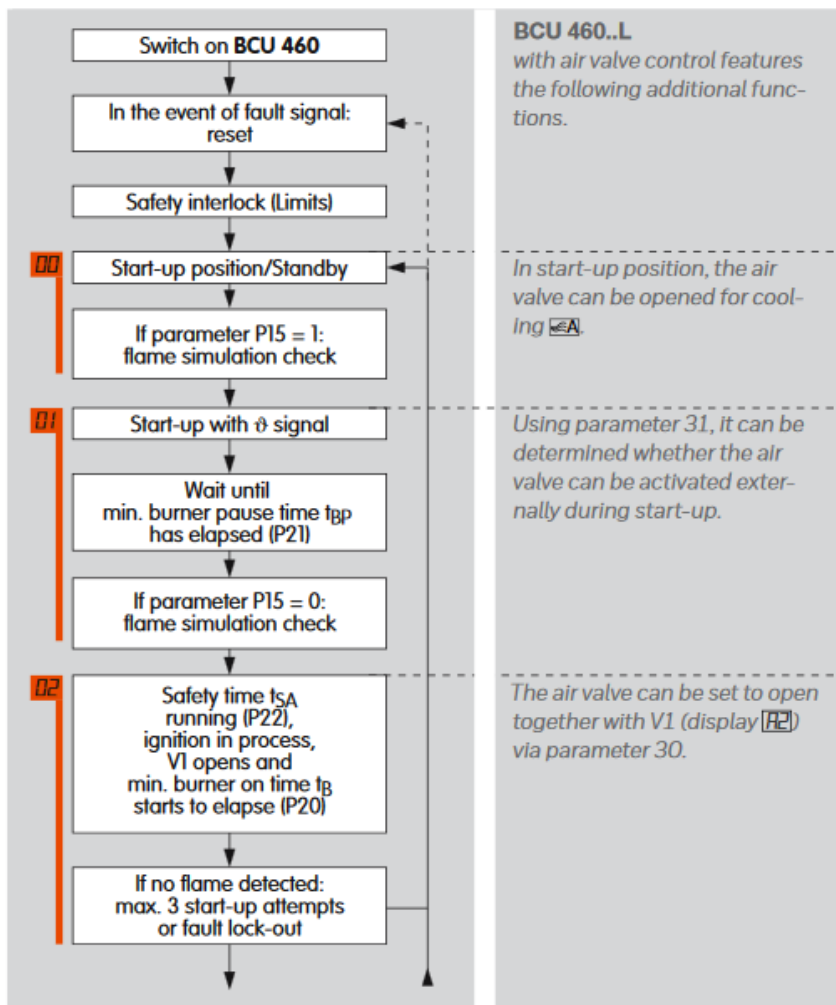

3.4 BCU 460 program sequence

Normal start-up

If an "old" fault is still being signalled after switching on, it will be necessary to reset this first.

When the safety interlocks are closed, the BCU reverts to start-up position and conducts a self-test. If it does not determine a malfunction of the internal electronic circuitry or of the flame sensor, the burner can be started.

The flame simulation check is conducted during start-up position or after applying the start-up signal (θ), depending on parameter 15. After the min. burner pause time t_{BP} has elapsed, the BCU opens valve V1 and ignites the burner. The ignition time t_z is constant.

If a flame is detected during the safety time t_{SA} , the flame proving period t_{rs} starts after this safety time has elapsed. Valve V2 opens and the operation signalling contact between terminals 16 and 17 closes.



บริษัท เอดีดี เฟอร์เนส จำกัด

ADD FURNACE CO.,LTD.

44 ซอยบรมราชชนนี 70 ถนนบรมราชชนนี แขวงศาลาธรรมสพน์ เขตทวีวัฒนา กรุงเทพฯ 10170

โทร: 02-888-3472 โทร: ออกแบบ:08-08-170-170 แฟกซ์: 02-888-3258

<https://www.add-furnace.com> E-mail: sales@add-furnace.com

Function

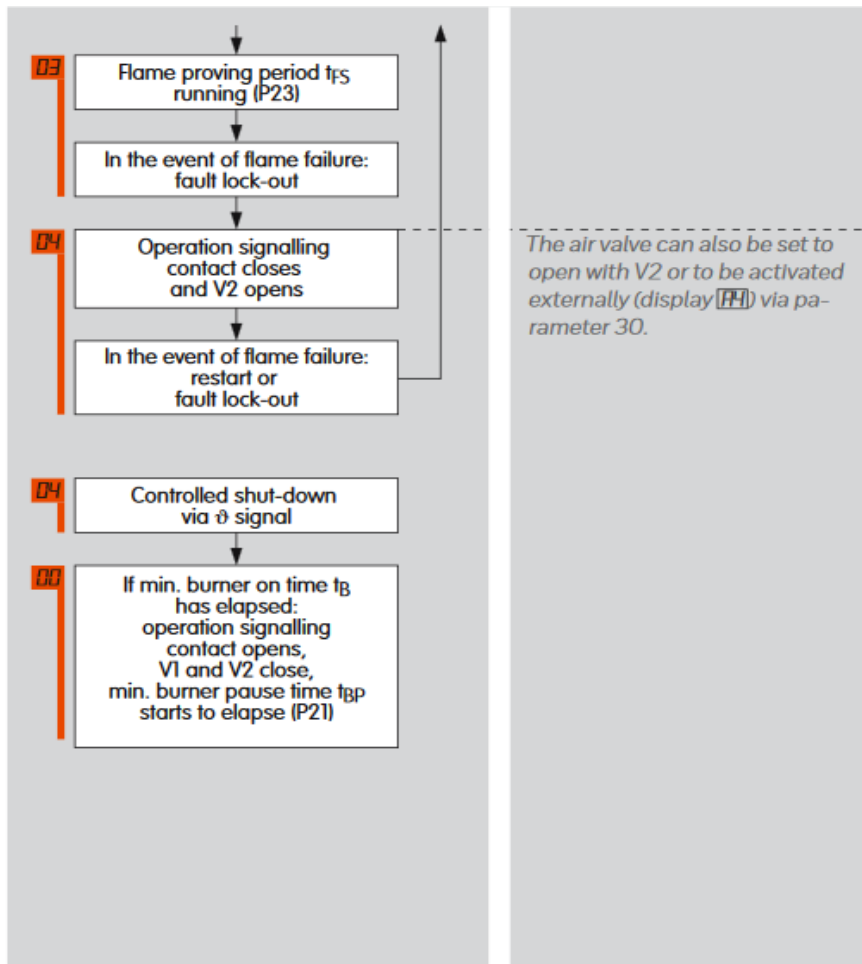

This completes start-up. An adjustable min.

burner on time t_B ensures that the burner burns for a defined period even if the start-up signal (θ) is switched off beforehand.

The burner can also be started manually with the aid of the switch on the BCU. Volt-age must be applied continuously to terminals 1, 4 and 5 in order for this to occur.

The BCU can also be operated in Manual mode for start-up.

Start-up without flame signal

If no flame is detected during the safety time t_{SA} , either a fault lock-out occurs or up to two further start-up attempts occur. The required functions and, if applicable, the number of start-up attempts must be specified when ordering. (Parameter 10, "Burner start-up attempts").

Behaviour in the event of flame failure during operation

If the flame fails during operation, either an immediate fault lock-out or a restart occurs. This procedure can be set via the optical interface (parameter 12, "Burner restart").



บริษัท เอดีดี เฟอร์เนส จำกัด

ADD FURNACE CO.,LTD.

44 ซอยบรมราชชนนี 70 ถนนบรมราชชนนี แขวงศาลาธรรมสพน์ เขตทวีวัฒนา กรุงเทพฯ 10170

โทร: 02-888-3472 โทร: ออกแบบ:08-08-170-170 แฟกซ์: 02-888-3258

<https://www.add-furnace.com> E-mail: sales@add-furnace.com

Function

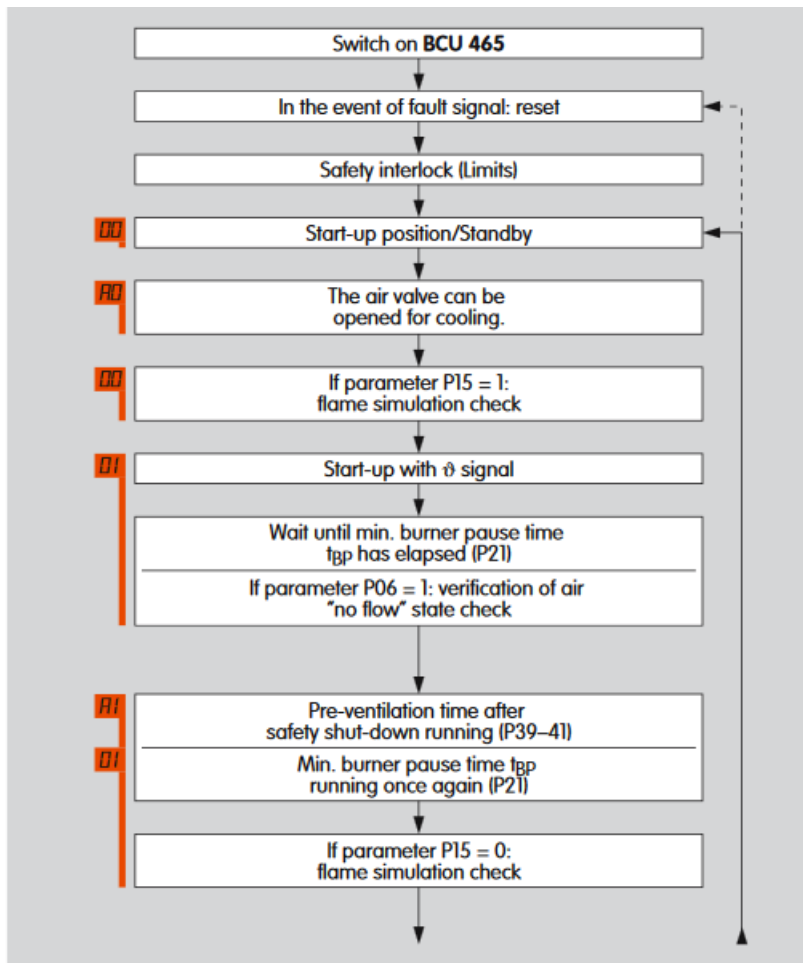

3.5 BCU 465 program sequence

Normal start-up

If an "old" fault is still being signalled after switching on, it will be necessary to reset this first.

When the safety interlocks are closed, the BCU reverts to start-up position and conducts a self-test. If it does not determine a malfunction of the internal electronic circuitry or of the flame sensor, the burner can be started.

The flame simulation check is conducted during start-up position or after applying the start-up signal (θ), depending on parameter 15.

After a safety shut-down, first the pre-ventilation time after safety shut-down elapses (parameters 39 – 41). Then the min. burner pause time t_{BP} runs. The BCU now opens valve V1 and ignites the burner. The ignition time t_z is constant.



บริษัท เอดีดี เฟอร์เนส จำกัด

ADD FURNACE CO.,LTD.

44 ซอยบรมราชชนนี 70 ถนนบรมราชชนนี แขวงศาลาธรรมสพน์ เขตทวีวัฒนา กรุงเทพฯ 10170

โทร: 02-888-3472 โทร: ออกแบบ:08-08-170-170 แฟกซ์: 02-888-3258

<https://www.add-furnace.com> E-mail: sales@add-furnace.com

Function

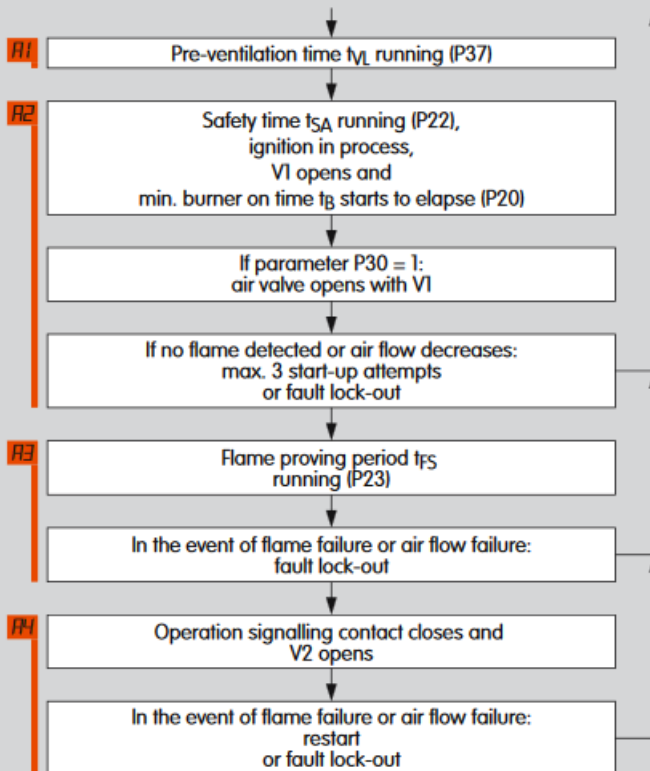

If both flame and air flow are detected during the safety time t_{SA} , the flame proving period t_{FS} starts after this safety time has elapsed. Valve V2 opens and the operation signalling contact between terminals 16 and 17 closes. This completes start-up. An adjustable min. burner on time t_B ensures that the burner burns for a defined period even if the start-up signal (θ) is switched off beforehand.

The burner can also be started manually with the aid of the switch on the BCU. Voltage must be applied continuously to terminals 1, 4 and 5 in order for this to occur.

The BCU can also be operated in Manual mode for start-up.



บริษัท เอดีดี เฟอร์เนส จำกัด

ADD FURNACE CO.,LTD.

44 ซอยบรมราชชนนี 70 ถนนบรมราชชนนี แขวงศาลาธรรมสพน์ เขตทวีวัฒนา กรุงเทพฯ 10170

โทร: 02-888-3472 โทร: ออกแบบ:08-08-170-170 แฟกซ์: 02-888-3258

<https://www.add-furnace.com> E-mail: sales@add-furnace.com

Function

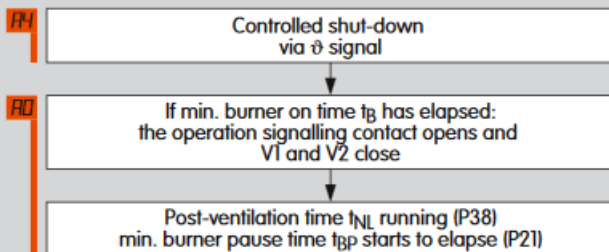

Start-up without flame signal/ without air flow

If no flame or no air flow is detected during start-up, either a fault lock-out occurs or up to two further start-up attempts occur. The required functions and, if applicable, the number of start-up attempts must be specified when ordering (parameter 10, "Burner start-up at-tempts").

Behaviour in the event of flame failure/air flow failure during operation

If the flame or air flow fails during operation, either an immediate fault lock-out or a restart occurs. This procedure can be set via the optical interface (parameter 12, "Burner restart").



บริษัท เอดีดี เฟอร์เนส จำกัด

ADD FURNACE CO.,LTD.

44 ซอยบรมราชชนนี 70 ถนนบรมราชชนนี แขวงศาลาธรรมสพน์ เขตทวีวัฒนา กรุงเทพฯ 10170

โทร: 02-888-3472 โทร: ออกแบบ:08-08-170-170 แฟกซ์: 02-888-3258

https://www.add-furnace.com E-mail: sales@add-furnace.com

Function

3.6 Program status and fault messages

Program status	DISPLAY	Fault message (flashing)	BCU 460	BCU 465	BCU 465T	BCU 460..B1	BCU 465..B1	BCU 465T..B1
BCU switched off	--					●	●	●
Start-up position/Standby	00		●	●	●	●	●	●
Purge	P0		○	●	●	○	●	●
Waiting time/Pause time	1	Flame simulation	●	●	●	●	●	●
Safety time on start-up	2	Start-up without flame signal	●	●	●	●	●	●
Flame proving period	3	Flame failure during flame proving period	●	●	●	●	●	●
Normal operation	4	Flame failure during operation	●	●	●	●	●	●
	10	Too many remote resets	●	●	●	●	●	●
Air valve	A		○	●	●	○	●	●
Pre-ventilation	A1			●	●		●	●
Post-ventilation	A0			●	●		●	●
Cooling	A0		○	●	●	○	●	●
	d0	Air pressure switch "no flow" state		●	●		●	●
	dP	No air flow during purge		●	●		●	●
POC (proof-of-closure)	c0	Fault Position indicator during start-up					●	●
POC (proof-of-closure)	c1	Valve not closed					●	●
POC (proof-of-closure)	cX	Fault Position indicator in position X					●	●
	dX	No air flow in position X		●	●		●	●
High temperature operation	..		○	○	○	○	○	○
	Pb	Bus fault				●	●	●



บริษัท เอดีดี เฟอร์เนส จำกัด

ADD FURNACE CO.,LTD.

44 ซอยบรมราชชนนี 70 ถนนบรมราชชนนี แขวงศาลาธรรมสพน์ เขตทวีวัฒนา กรุงเทพฯ 10170

โทร: 02-888-3472 โทร: ออกแบบ:08-08-170-170 แฟกซ์: 02-888-3258

<https://www.add-furnace.com> E-mail: sales@add-furnace.com

Function

Program status	DISPLAY	Fault message (flashing)	BCU 460	BCU 465	BCU 465T	BCU 460..B1	BCU 465..B1	BCU 465T..B1
	30	EEPROM data change, NFS*				●	●	●
	31	EEPROM data change, FS*				●	●	●
	32	Undervoltage in power pack				●	●	●
	33	Faulty parameterization				●	●	●
	bE	Bus module fault				●	●	●
	51	Safety interlock failure	●	●	●	●	●	●
	52	Permanent remote reset	●	●	●	●	●	●
	53	Timing cycle too short	●	●	●	●	●	●

In Manual mode, two dots will blink on the display in program status 01–04 .

* FS = input/output, safety circuit, NFS = input/output, control system



บริษัท เอดีดี เฟอร์เนส จำกัด

ADD FURNACE CO.,LTD.

44 ซอยบรมราชชนนี 70 ถนนบรมราชชนนี แขวงศาลาธรรมสพน์ เขตทวีวัฒนา กรุงเทพฯ 10170

โทร: 02-888-3472 โทร: ออกแบบ:08-08-170-170 แฟกซ์: 02-888-3258

<https://www.add-furnace.com> E-mail: sales@add-furnace.com

Parameters

4 Parameters

Description	Parameter	Value range	Factory default setting	Adjustable*	BCU 460 (BCU 460..B1)	BCU 465 (BCU 465..B1)	BCU 465T (BCU 465T..B1)
Burner flame signal	01	0–99 μ A					
Program status on last fault	03	x0–x8					
Switch-off threshold of the flame amplifier	04	1–20 μ A	1 μ A				
Air flow monitoring during purging (BCU 465..L)	06	0; 1	1			**	
Air flow monitoring during operation (BCU 465..L)	07	0; 1	1			**	
Delayed air flow monitoring (BCU 465)	08	0; 1	0			**	
Position indicator input on BCU 465T..O (POC)	09	0; 1	1				**
Burner start-up attempts	10	1–3	1		**	**	**
Fault lock-out or restart	12	0; 1	0				
Safety time during operation t_{SB} for V1 and V2	14	1; 2 s	1 s		**	**	**
Flame-simulation check in start-up position/standby	15	0; 1	1				
Minimum burner on time t_B	20	t_{SA} –25 s	t_{SA}				
Minimum burner pause time t_{BP}	21	0–250 s	0 s				
Safety time on start-up t_{SA}	22	3; 5; 10 s			**	**	**
Flame proving period t_{FS}	23	0–25 s	0 s				
Air valve control on BCU..L	30	0; 1; 2; 3	0				
Air valve control on BCU..L	31	0; 1	0				
Behaviour of the air valve after a fault lock-out	32	0; 1	1				
High temperature operation in the case of BCU..D2 or BCU..D3	33	2; 3			**	**	**
Manual mode limited to 5 minutes	34	0; 1	1				
UVS check	35	0; 1	0				
Low fire over run-time t_{KN} after a controlled shut-down	36	0; 5; 15; 25 s	0 s		**	**	**



บริษัท เอดีดี เฟอร์เนส จำกัด

ADD FURNACE CO.,LTD.

44 ซอยบรมราชชนนี 70 ถนนบรมราชชนนี แขวงศาลาธรรมสพน์ เขตทวีวัฒนา กรุงเทพฯ 10170

โทร: 02-888-3472 โทร: ออกแบบ:08-08-170-170 แฟกซ์: 02-888-3258

<https://www.add-furnace.com> E-mail: sales@add-furnace.com

Parameters

Description	Parameter	Value range	Factory default setting	Adjustable*	BCU 460 (BCU 460..B1)	BCU 465 (BCU 465..B1)	BCU 465T (BCU 465T..B1)
Pre-ventilation time t_{VL} before start-up (BCU 465..L)	37	0–250 s	0 s				
Post-ventilation time t_{NL} after a controlled shut-down (BCU 465..L)	38	0–3 s	0 s				
Pre-ventilation time after safety shut-down (BCU 465..L)	39	0–250 s	0 s			**	**
Pre-ventilation for restart/start-up attempts (BCU 465..L)	40	0; 1	1			**	**
Pre-ventilation after reset (BCU 465..L)	41	0; 1	1			**	**

= standard, = available.

* Adjustable using BCSoft software and a PC opto-adapter

** Please quote in your order

0 = Function inactive,

1 = Function active.

4.1 Scanning the parameters

During operation, the 7-segment display shows the program status, see page 39 (Program status and fault messages).

The flame signal and all following parameters of the BCU can be scanned one after the other by repeatedly pressing the Reset/Information button (for 2 seconds).

In the event of a fault, the BCU halts the program run, the display blinks and it then displays the cause of the fault in coded form.



บริษัท เอดีดี เฟอร์เนส จำกัด

ADD FURNACE CO.,LTD.

44 ซอยบรมราชชนนี 70 ถนนบรมราชชนนี แขวงศาลาธรรมสพน์ เขตทวีวัฒนา กรุงเทพฯ 10170

โทร: 02-888-3472 โทร: ออกแบบ:08-08-170-170 แฟกซ์: 02-888-3258

<https://www.add-furnace.com> E-mail: sales@add-furnace.com

Parameters

4.2 Flame control

4.2.1 Burner flame signal

Parameter 01

Flame signal of the burner, display in μA , measuring range: 0 – 30 μA .

4.2.2 Switch-off threshold of the flame amplifier

Parameter 04

The sensitivity at which the burner control unit still detects a flame can be set between 1 and 20 μA .

Example: in the case of UV control with the UV sensor UVS, the signal of the burner to be monitored is influenced by other burners.

The set value can be incremented in parameter 04 so that only the flame of the system's "own" burner is detected.

The measured flame signal of the system's "own" burner should be at least 3 μA (empirical value) higher than the set switch-off threshold.



บริษัท เอดีดี เฟอร์เนส จำกัด

ADD FURNACE CO.,LTD.

44 ซอยบรมราชชนนี 70 ถนนบรมราชชนนี แขวงศาลาธรรมสพน์ เขตทวีวัฒนา กรุงเทพฯ 10170

โทร: 02-888-3472 โทร: ออกแบบ:08-08-170-170 แฟกซ์: 02-888-3258

https://www.add-furnace.com E-mail: sales@add-furnace.com

Parameters

4.2.3 High temperature operation in the case of BCU..D2 or BCU..D3

Parameter 33

Operation of firing systems at temperatures above 750°C. The BCU features a fail-safe DI input (DI = Digital Input).

This input supports the "High temperature operation" function. If firing systems are operated above 750°C, the system is considered to be a high temperature equipment (see EN 746-2). Flame control must be in operation until the furnace wall temperature has exceeded 750 °C.

Frequently, flame control is dispensed with so as to achieve a particularly high flexibility of the installation. This means that no incorrect flame signals, e.g. signals from a UV sensor which are interpreted as extraneous signals due to reflection of UV radiation, may lead to faults.

When the DI input is activated, the burner control unit reverts to this operating mode, i.e.: **the BCU operates without evaluation of the flame signal.. The safety function of the device-internal flame control system is placed out of operation..**

In High temperature mode, the gas valves are opened without flame control.

The precondition for this operating mode is that an

external flame supervision device ensures the presence of the flame in fail-safe manner indirectly via the temperature.

For this purpose, we recommend a safety temperature monitor with double thermocouple (DIN 3440). Sensor discontinuity, sensor short-circuit, failure of a component or mains failure must set the installation to a safe state.

The voltage may be applied to the DI input (terminal 6) so as to activate High temperature operation only when the temperature at the furnace wall has exceeded 750°C.

The BCU then starts the burner as usual but without monitoring the presence of the flame.

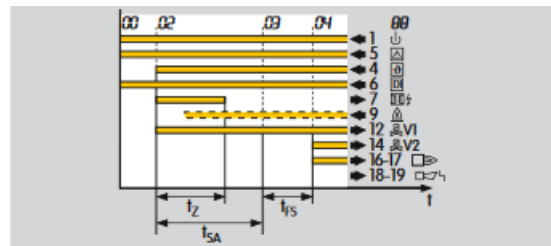

If the temperature in the furnace chamber drops below 750°C, the DI input must be disconnected from the electrical power supply and the furnace must then be operated with flame control.



บริษัท เอดีดี เฟอร์เนส จำกัด

ADD FURNACE CO.,LTD.

44 ซอยบรมราชชนนี 70 ถนนบรมราชชนนี แขวงศาลาธรรมสพน์ เขตทวีวัฒนา กรุงเทพฯ 10170

โทร: 02-888-3472 โทร: ออกแบบ:08-08-170-170 แฟกซ์: 02-888-3258

https://www.add-furnace.com E-mail: sales@add-furnace.com

Parameters

The BCU then responds, depending on setting:

Parameter 33 = 2 (BCU..D2)

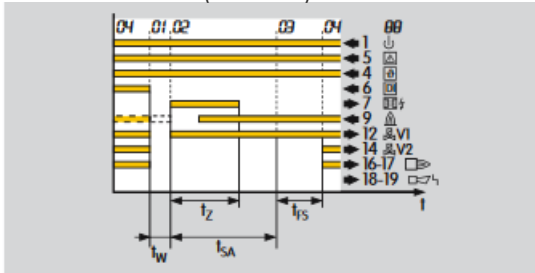

The BCU switches off the burner and restarts with flame simulation check (recommended in the case of UV control with UVS).

Parameter 33 = 3 (BCU..D3)

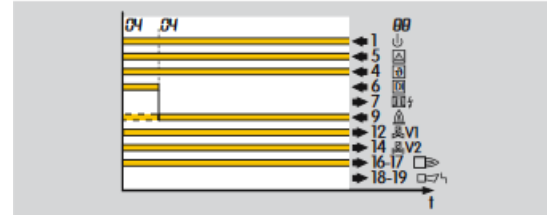

The burner remains in operation and the BCU performs flame control again (recommended in the case of ionization control or UV control with UVD). If no flame signal is present when High temperature operation is deactivated, the burner control unit performs a fault lock-out, regardless of parameter 33.

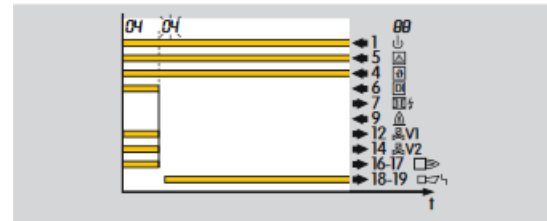

Note the requirements of the Standards!



บริษัท เอดีดี เฟอร์เนส จำกัด

ADD FURNACE CO.,LTD.

44 ซอยบรมราชชนนี 70 ถนนบรมราชชนนี แขวงศาลาธรรมสพน์ เขตทวีวัฒนา กรุงเทพฯ 10170

โทร: 02-888-3472 โทร: ออกแบบ:08-08-170-170 แฟกซ์: 02-888-3258

<https://www.add-furnace.com> E-mail: sales@add-furnace.com

Parameters

4.2.4 UVS check

Parameter 35

An automatic restart of the burner control unit can be activated every 24 hours via this parameter. The time starts each time the start-up signal (๑) is applied.

Parameter 35 = 0: unlimited burner operation.

Parameter 35 = 1: an automatic restart is activated once every 24 hours.

UV sensor for intermittent operation

For intermittent operation, the operating state of the complete system is limited to 24 h pursuant to EN 298. To meet the requirement for intermittent operation, the burner is shut down and restarted automatically after an operating time of 24 hours. The restart does not meet the requirements of EN 298 for UV sensor continuous operation because the required self-test (at least once per hour) is not performed while the burner is operating.

This shut-down and subsequent restart are performed in the same way as a normal controlled shut-down. This process is controlled independently by the BCU and therefore it must be checked whether the industrial process permits the pause in heat supply it creates.



บริษัท เอดีดี เฟอร์เนส จำกัด

ADD FURNACE CO.,LTD.

44 ซอยบรมราชชนนี 70 ถนนบรมราชชนนี แขวงศาลาธรรมสพน์ เขตทวีวัฒนา กรุงเทพฯ 10170

โทร: 02-888-3472 โทร: ออกแบบ:08-08-170-170 แฟกซ์: 02-888-3258

https://www.add-furnace.com E-mail: sales@add-furnace.com

Parameters

4.3 Behaviour in start-up position/standby

4.3.1 Flame-simulation check in start-up position/standby

Parameter 15

This defines the instant for the flame simulation check.

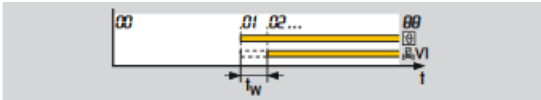

Parameter 15 = 0: The flame simulation check is conducted after applying the start-up signal (0) during the waiting time t_w .



Parameter 15 = 1: The flame simulation check is conducted provided no start-up signal (0) is applied (during the so-called start-up position/standby). This allows fast start-up of the burner since there is no waiting time t_w .

The burner must have been switched off for at least 4 s before start-up in order for the flame simulation check to be conducted correctly.

What is an extraneous signal?

An extraneous signal is an incorrect signal which is

detected as a flame signal out of sequence. If the BCU460 or BCU 465 notices such an extraneous signal during the flame simulation check, it starts the flame simulation delay time t_{LV} for 25 s. If the extraneous signal is discontinued during this period, the burner can start up. Otherwise, a fault lock-out occurs. 01 blinks on the display.

Flame simulation check in standby position (parameter 15 = 1):

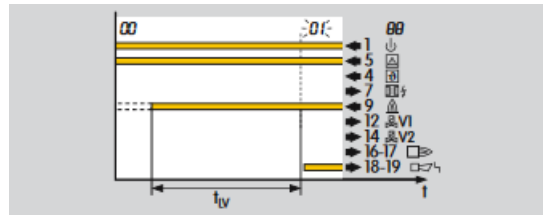

Flame simulation check on start-up (parameter 15 = 0):

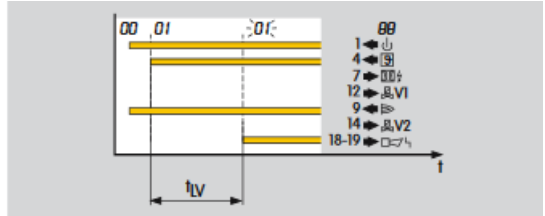

The flame simulation check of the burner is active until valve V1 is enabled.



บริษัท เอดีดี เฟอร์เนส จำกัด

ADD FURNACE CO.,LTD.

44 ซอยบรมราชชนนี 70 ถนนบรมราชชนนี แขวงศาลาธรรมสพน์ เขตทวีวัฒนา กรุงเทพฯ 10170

โทร: 02-888-3472 โทร: ออกแบบ:08-08-170-170 แฟกซ์: 02-888-3258

<https://www.add-furnace.com> E-mail: sales@add-furnace.com

Parameters

4.3.2 Position indicator input on BCU 465T..O (POC)

Parameter 09

For applications in accordance with the requirements of NFPA 86:2003 with more than 117 kW (400,000 BTU/h), two gas solenoid valves are required, one of which is to be equipped with a position indicator.

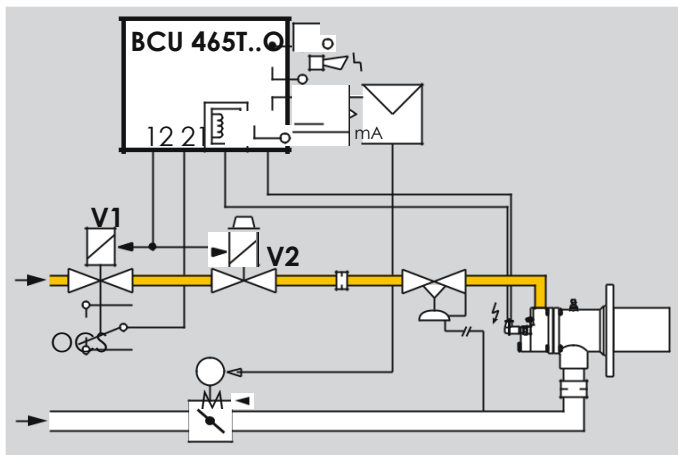

Parameter 09 = 1: A signal is sent to the BCU via the position indicator on the gas solenoid valve V1 stating whether the valve is closed or open. In standby, the switch must be closed. During start-up and operation, the switch must be open. This ensures that valve V1 is open or closed.



บริษัท เอดีดี เฟอร์เนส จำกัด

ADD FURNACE CO.,LTD.

44 ซอยบรมราชชนนี 70 ถนนบรมราชชนนี แขวงศาลาธรรมสพน์ เขตทวีวัฒนา กรุงเทพฯ 10170

โทร: 02-888-3472 โทร: ออกแบบ:08-08-170-170 แฟกซ์: 02-888-3258

https://www.add-furnace.com E-mail: sales@add-furnace.com

Parameters

4.3.3 Minimum burner pause time t_{BP}

Parameter 21

Programmable time between 0 and 250 s.

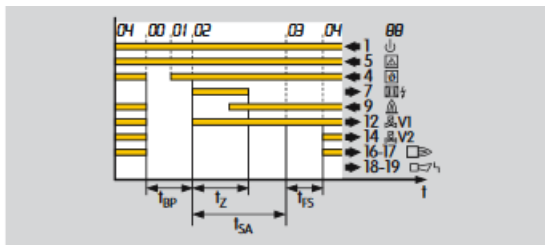

An immediate restart of the burner after a controlled shut-down is prevented by the pause time. The pause time starts when the burner is switched off. If a start-up signal (๑) is applied before expiry of this time, start-up is delayed until the end of the pause time.

After the pause time, the burner is started if the start-up signal (๑) is applied.

The minimum burner pause time t_{BP} serves to adapt the program sequence to the requirements of the application.

The time should be set such that the system can be moved to ignition position, i.e. air valves or butterfly valves can be closed and, possibly, gas can be flared off, before a restart occurs.

Example of application

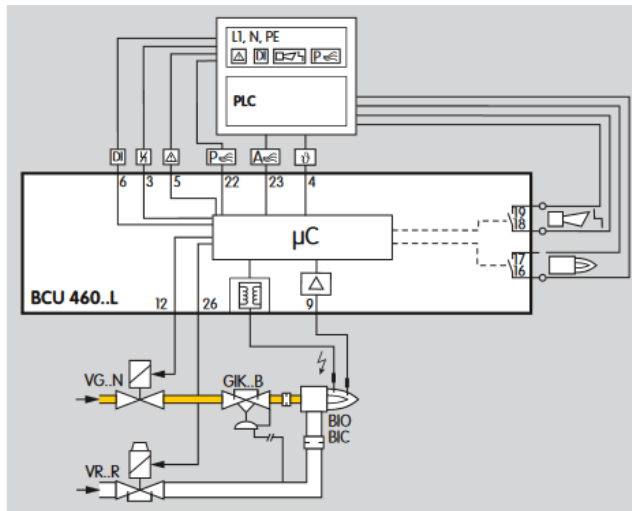



บริษัท เอดีดี เฟอร์เนส จำกัด

ADD FURNACE CO.,LTD.

44 ซอยบรมราชชนนี 70 ถนนบรมราชชนนี แขวงศาลาธรรมสพน์ เขตทวีวัฒนา กรุงเทพฯ 10170

โทร: 02-888-3472 โทร: ออกแบบ:08-08-170-170 แฟกซ์: 02-888-3258

<https://www.add-furnace.com> E-mail: sales@add-furnace.com

Parameters

4.4 Behaviour during start-up

4.4.1 Safety time on start-up t_{SA}

Parameter 22

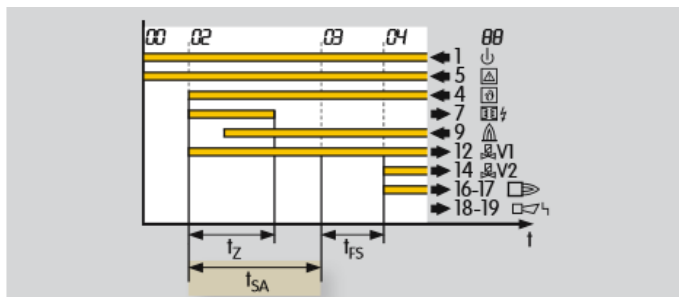

This indicates the safety time on start-up t_{SA} for the burner.

4.4.2 Minimum burner on time t_B

Parameter 20

Programmable time in the range from minimum safety time on start-up t_{SA} to maximum 25 s during which the burner remains in operation.

In the case of brief activation of the start-up signal input (9) (e.g. with a pulse), the burner on time t_B is started, and the burner remains in operation for at least this period. This time is independent of the pre-ventilation time.

4.4.3 Flame proving period t_{FS}

Parameter 23

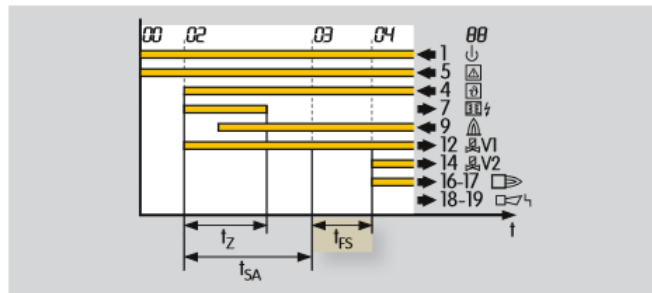

Programmable time between 0 and 25 s.

This time elapses before the BCU starts the next program step so as to give the flame time to stabilize.

4.4.4 Burner start-up attempts

Parameter 10

This indicates the number of possible start-up attempts of the burner.

In accordance with EN 746-2, a maximum of three start-ups are permitted in specific cases if the safety of the installation is not impaired. Note the requirements of the Standards!

If no flame is detected or, in the case of BCU 465, if the air flow fails during start-up, either a fault lock-out occurs or up to two further start-up attempts occur. The required functions and, if applicable, the number of start-up attempts must be specified when ordering.



บริษัท เอดีดี เฟอร์เนส จำกัด

ADD FURNACE CO.,LTD.

44 ซอยบรมราชชนนี 70 ถนนบรมราชชนนี แขวงศาลาธรรมสพน์ เขตทวีวัฒนา กรุงเทพฯ 10170

โทร: 02-888-3472 โทร: ออกแบบ:08-08-170-170 แฟกซ์: 02-888-3258

<https://www.add-furnace.com> E-mail: sales@add-furnace.com

Parameters

1 start-up attempt

2 Parameter 10 = 1

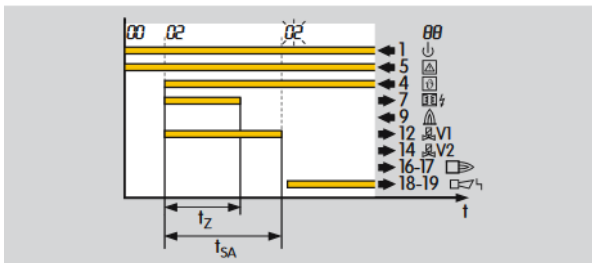

If no flame forms or, in the case of BCU 465, if the air flow fails during start-up, a fault lock-out is performed after expiry of time t_{SA} . The display blinks and shows the cause of the fault.

2-3 start-up attempts

Parameter 10 = 2-3

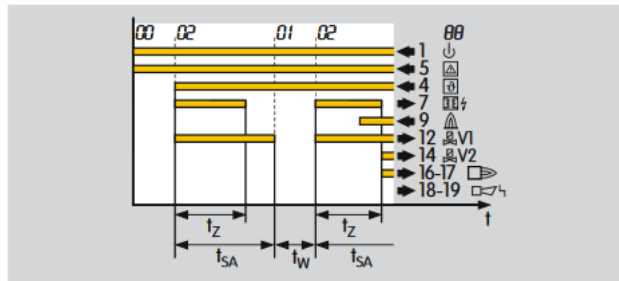

If several start-up attempts are set at the works and if the BCU detects an installation fault during start-up, it closes valve V1 after the safety time t_{SA} has expired and attempts to start up again. After the last programmed start-up attempt has been completed, the burner control unit conducts a fault lock-out. The display blinks and shows the cause of the fault.



บริษัท เอดีดี เฟอร์เนส จำกัด

ADD FURNACE CO.,LTD.

44 ซอยบรมราชชนนี 70 ถนนบรมราชชนนี แขวงศาลาธรรมสพน์ เขตทวีวัฒนา กรุงเทพฯ 10170

โทร: 02-888-3472 โทร: ออกแบบ:08-08-170-170 แฟกซ์: 02-888-3258

<https://www.add-furnace.com> E-mail: sales@add-furnace.com

Parameters

4.5 Behaviour during operation

4.5.1 Safety time during operation t_{SB} for V1 and V2

Parameter 14

This indicates the safety time during operation t_{SB} for valves V1 and V2.

The default in accordance with EN 298 is 1 s.

The BCU has also the available option of t_{SB} of 2 s. Prolonging the time increases the installation availability in the case of brief-duration signal fades (e.g. fades of the flame signal or, on BCU 465, in the case of pressure switch drop-out).

In accordance with EN 746-2, the safety time of the installation during operation (including closing time of the valves) may not exceed 3 s.

Note the requirements of the Standards!

4.5.2 Fault lock-out or restart

Parameter 12

This parameter determines whether the BCU starts a one-off restart or performs an immediate fault lock-out for the burner after an installation fault (flame failure or failure of air flow).



บริษัท เอดีดี เฟอร์เนส จำกัด

ADD FURNACE CO.,LTD.

44 ซอยบรมราชชนนี 70 ถนนบรมราชชนนี แขวงศาลาธรรมสพน์ เขตทวีวัฒนา กรุงเทพฯ 10170

โทร: 02-888-3472 โทร: ออกแบบ:08-08-170-170 แฟกซ์: 02-888-3258

<https://www.add-furnace.com> E-mail: sales@add-furnace.com

Parameters

4.5.3 Immediate fault lock-out after installation fault

Parameter 12 = 0: Fault lock-out after installation fault.

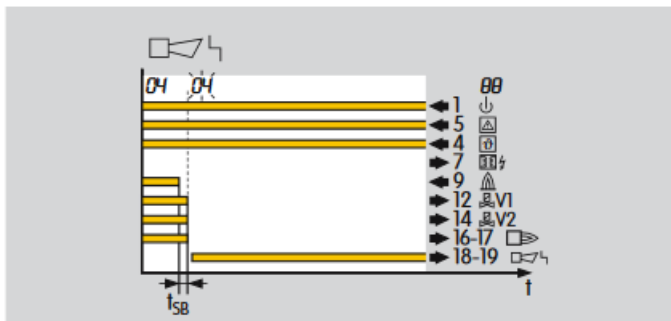

After an installation fault (flame failure or failure of air flow), the burner control unit performs a fault lock-out within the safety time during operation t_{SB} . This involves disconnecting the power from the gas valves and, if applicable, the ignition transformer. The fault signalling contact closes, the display blinks and shows the current program status, see table on page 39 (Program status and fault messages).

See also parameter 32, page 59 (Behaviour of the air valve after a fault lock-out).

After a fault lock-out, the burner control unit can be reset, either with the button on the front panel or using an external button. Several burner control units can be reset in parallel using the external button.

The BCU cannot be reset by mains failure. The fault signalling contact does, however, open as soon as the mains voltage fails.

Restart following flame failure

Parameter 12 = 1: Restart after installation fault.

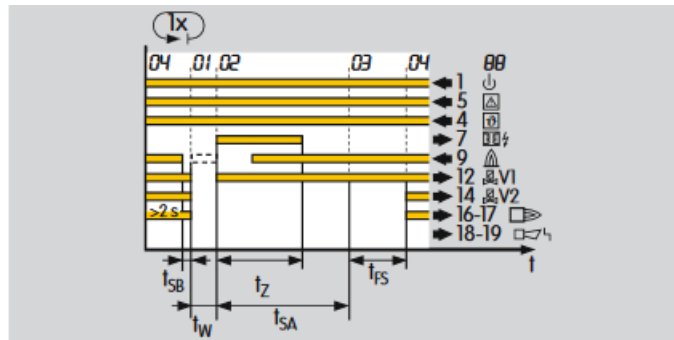

If the BCU detects an installation fault (flame failure or failure of air flow) after a minimum operating time of 2 s,

the valves are closed and the operation signalling contact is opened within time t_{SB} .

The burner control unit now attempts to restart the burner once. If the burner does not function, a fault lock-out is performed. The display blinks and shows the cause of the fault.

In accordance with EN 746-2, a restart may be conducted only if the safety of the installation is not impaired. Restart is recommended for burners which occasionally display unstable behaviour during operation.

The precondition for a restart is that activation of the restart allows the burner to restart as intended (in all operating phases). In this case, it must be ensured that the program sequence started by the BCU matches the application.



บริษัท เอดีดี เฟอร์เนส จำกัด

ADD FURNACE CO.,LTD.

44 ซอยบรมราชชนนี 70 ถนนบรมราชชนนี แขวงศาลาธรรมสพน์ เขตทวีวัฒนา กรุงเทพฯ 10170

โทร: 02-888-3472 โทร: ออกแบบ:08-08-170-170 แฟกซ์: 02-888-3258

<https://www.add-furnace.com> E-mail: sales@add-furnace.com

Parameters

4.5.4 Program status on last fault

Parameter 03

This indicates the program status in which the last burner fault occurred.

Example: the unit indicates that the safety interlocks have been interrupted with a blinking 51.

Parameter 03 can now be used to scan in what program status the BCU was when the fault was detected.



บริษัท เอดีดี เฟอร์เนส จำกัด

ADD FURNACE CO.,LTD.

44 ซอยบรมราชชนนี 70 ถนนบรมราชชนนี แขวงศาลาธรรมสพน์ เขตทวีวัฒนา กรุงเทพฯ 10170

โทร: 02-888-3472 โทร: ออกแบบ:08-08-170-170 แฟกซ์: 02-888-3258

<https://www.add-furnace.com> E-mail: sales@add-furnace.com

Parameters

4.6 Air valve control on BCU..L

Parameter 30, "Air valve control"

Parameter 31, "Air valve can be activated externally on start-up"

Parameter 32, "Air valve: closed/can be activated in the event of malfunction"

The BCU..L features an adjustable air valve control. The display shows that purging is currently being carried out with PO. A indicates that the air valve is being activated for cooling or heating. The BCU supports the following functions:

4.6.1 Purge

In the case of multiple burner applications, burners with mechanical combustion air supply are used. The air for combustion and pre-purge is supplied by a central fan controlled by a separate logic. This logic determines the purging time.

The BCU..L..E1 (BCU with adapted power management) supports centrally-controlled pre-purge or post-purge. The BCU..L is informed that purging is currently being performed by input 22. It then opens the air valve, regardless of the status of the other inputs (purging has priority). The display indicates PO.

On BCUs without power management, input 22 and input 5 (safety interlocks) must be activated for purging, see from page 13 (Connection diagrams).



บริษัท เอดีดี เฟอร์เนส จำกัด

ADD FURNACE CO.,LTD.

44 ซอยบรมราชชนนี 70 ถนนบรมราชชนนี แขวงศาลาธรรมสพน์ เขตทวีวัฒนา กรุงเทพฯ 10170

โทร: 02-888-3472 โทร: ออกแบบ:08-08-170-170 แฟกซ์: 02-888-3258

<https://www.add-furnace.com> E-mail: sales@add-furnace.com

Parameters

4.6.2 Cooling in start-up position/standby

The air valve can be activated externally by input 23 for cooling in the start-up position. During activation of the air valve, the display shows **A0**, indicating that cooling is currently being carried out.

Parameters 30 and 31 determine the behaviour of the air valve during burner start.

4.6.3 Air valve opens in the case of external activation (not during start-up)

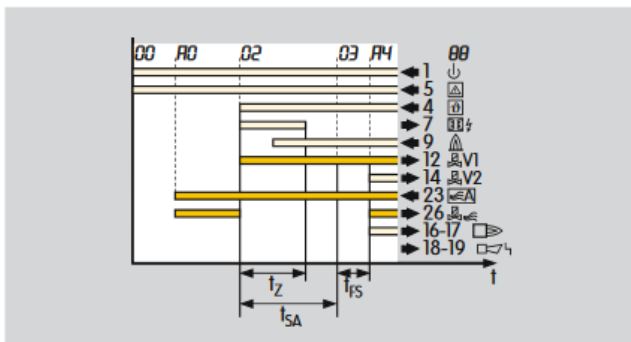

BCU 460, BCU 465 · Edition 03.161

Parameter 30 = 0: The air valve opens if it is activated externally by input 23.

Parameter 31 = 0: The air valve remains closed during start-up even if it is activated externally.

These settings are required on burners on which the gas/air ratio is controlled by a pneumatic air/gas ratio control system link and which also need to be started at low fire, e.g. on two-stage-controlled burners, see page 8 (BCU 460..L: Two-stage-controlled burner). In this case, activation of the air valve during burner start via input 23 must be prevented.

External control allows switchover between low fire and high fire during operation.



บริษัท เอดีดี เฟอร์เนส จำกัด

ADD FURNACE CO.,LTD.

44 ซอยบรมราชชนนี 70 ถนนบรมราชชนนี แขวงศาลาธรรมสพน์ เขตทวีวัฒนา กรุงเทพฯ 10170

โทร: 02-888-3472 โทร: ออกแบบ:08-08-170-170 แฟกซ์: 02-888-3258

https://www.add-furnace.com E-mail: sales@add-furnace.com

Parameters

4.6.4 Air valve opens in the case of external activation (even during start-up)

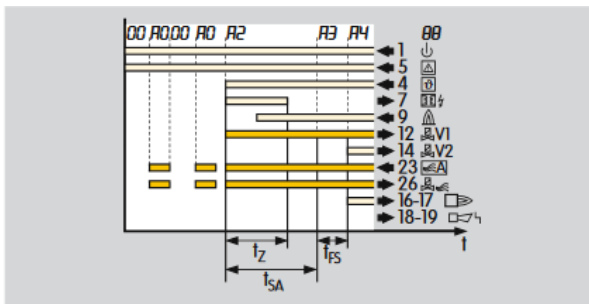

Parameter 30 = 0: The air valve opens if it is activated externally by input 23.

Parameter 31 = 1: The air valve can be activated even during start-up.

These settings may be selected only if the burner can start with full air capacity.

4.6.5 Air valve opens with valve V1

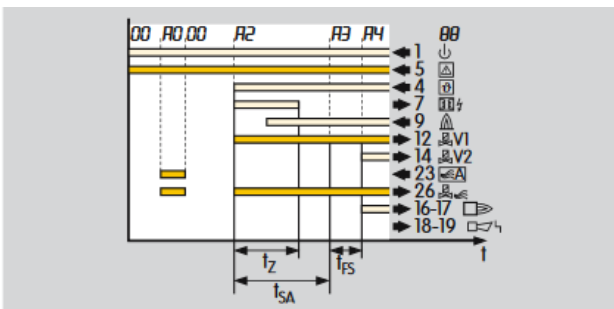

Parameter 30 = 1: The air valve opens simultaneously with valve V1.

It can be activated externally via input 23 for cooling the burner in the start-up position/standby.

4.6.6 Air valve opens with valve V2

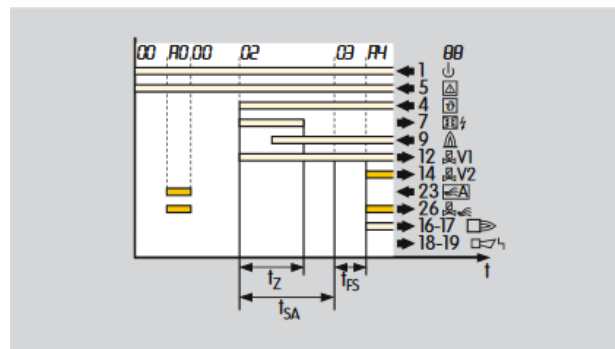

Parameter 30 = 2: The air valve opens simultaneously with valve V2.

It can be activated externally via input 23 for cooling the burner in the start-up position/standby.



บริษัท เอดีดี เฟอร์เนส จำกัด

ADD FURNACE CO.,LTD.

44 ซอยบรมราชชนนี 70 ถนนบรมราชชนนี แขวงศาลาธรรมสพน์ เขตทวีวัฒนา กรุงเทพฯ 10170

โทร: 02-888-3472 โทร: ออกแบบ:08-08-170-170 แฟกซ์: 02-888-3258

<https://www.add-furnace.com> E-mail: sales@add-furnace.com

Parameters

4.6.7 Low fire over run-time t_{KN} after a controlled shut-down

Parameter 36

Value range 0, 5, 15 or 25 s

This parameter is applicable to systems with pneumatic air/gas ratio control system and On/Off control.

Parameter 36 $t_{KN} = 0$: Without low fire over-run, the gas circuit is closed immediately owing to the quick-closing gas valve in the case of On/Off control. The air circuit closes more slowly. The air flowing in during the closing time increases the O₂ percentage in the combustion chamber.

Parameter 36 $t_{KN} = 5, 15$ or 25 s: The air valve is closed with deactivated start-up signal (9). The gas valve remains open for t_{KN} . This means that the burner, after deactivation of the start-up signal (9), is initially adjusted down to low fire and then switched off completely.

Using the low fire over-run function reduces the O₂ percentage in the furnace atmosphere.

Flame control is still operational.

Can be used only in the case of a pneumatic air/gas ratio control system and On/Off control.

It must be ensured that no excess gas occurs.

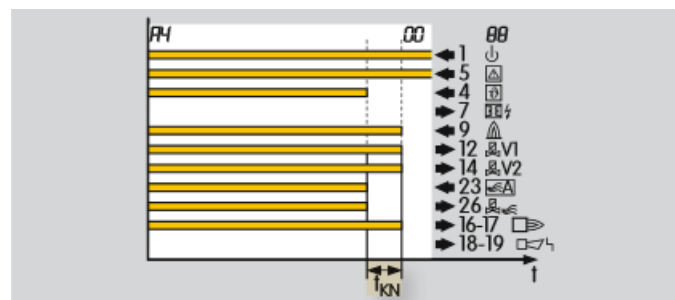
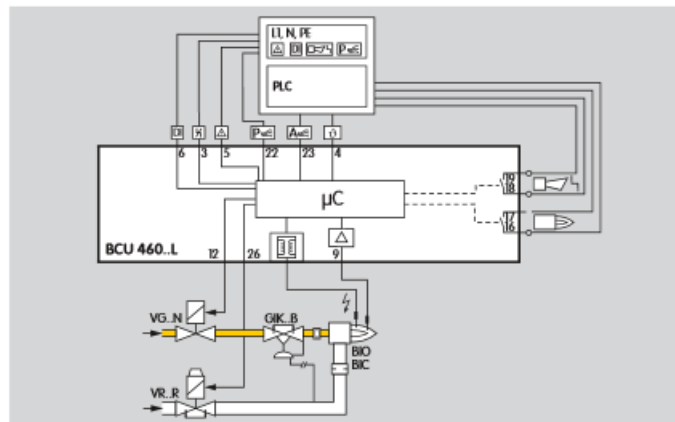



บริษัท เอดีดี เฟอร์เนส จำกัด

ADD FURNACE CO.,LTD.

44 ซอยบรมราชชนนี 70 ถนนบรมราชชนนี แขวงศาลาธรรมสพน์ เขตทวีวัฒนา กรุงเทพฯ 10170

โทร: 02-888-3472 โทร: ออกแบบ:08-08-170-170 แฟกซ์: 02-888-3258

<https://www.add-furnace.com> E-mail: sales@add-furnace.com

Parameters

4.6.8 Behaviour of the air valve after a fault lock-out

Parameter 32

This determines whether the air valve can be activated in the case of a fault lock-out.

Parameter 32 = 0: The air valve is closed in the event of a fault. It cannot be activated externally.

Parameter 32 = 1: The air valve can be activated externally by input 23 even during a fault, e.g. for cooling.



บริษัท เอดีดี เฟอร์เนส จำกัด

ADD FURNACE CO.,LTD.

44 ซอยบรมราชชนนี 70 ถนนบรมราชชนนี แขวงศาลาธรรมสพน์ เขตทวีวัฒนา กรุงเทพฯ 10170

โทร: 02-888-3472 โทร: ออกแบบ:08-08-170-170 แฟกซ์: 02-888-3258

<https://www.add-furnace.com> E-mail: sales@add-furnace.com

Parameters

4.7 Extended air control with BCU 465..L

For use on recuperative burners, the BCU 465..L features an extended air control which meets the specific requirements of such burners.

4.7.1 Air flow monitoring during purging (BCU 465..L)

Parameter 06

This parameter determines whether the air flow is monitored during prepurge.

Parameter 06 = 0: The air flow is not monitored during prepurge.

Parameter 06 = 1: The air flow is monitored during prepurge (pressure switch signal at terminal 21), i.e.

Check of the LOW signal (pressure switch contact open)

No air may flow before pre-purge. A LOW signal must be applied to the pressure switch. If the LOW signal is not applied, the BCU performs a fault lock-out after expiry of a delay time (as long as the flame simulation de-lay time t_{LV}). Fault message: 0, "no flow" state check failed.

Check of the HIGH signal (pressure switch contact closed)

The air must flow and a HIGH signal must be applied to the pressure switch during pre-purge. If the HIGH signal is not applied, the BCU performs a fault lock-out after expiry of the testing time (as long as the safety time on start-up). Fault message: dP, no air flow.



บริษัท เอดีดี เฟอร์เนส จำกัด

ADD FURNACE CO.,LTD.

44 ซอยบรมราชชนนี 70 ถนนบรมราชชนนี แขวงศาลาธรรมสพน์ เขตทวีวัฒนา กรุงเทพฯ 10170

โทร: 02-888-3472 โทร: ออกแบบ:08-08-170-170 แฟกซ์: 02-888-3258

https://www.add-furnace.com E-mail: sales@add-furnace.com

Parameters

4.7.2 Pre-ventilation time t_{VL} before start-up (BCU

465..L)

Parameter 37

Value range 0 – 250 s

This can be set in 0.1 s steps in the range 0 to 10 s,
in 1 s steps in the range 10 to 250 s.

This parameter is used to determine the time during
which the air valve is already open before normal
startup. This time may also be used for pre-purge.

Suitable for burners starting with full air capacity.

Parameter 37 > 0 up to max. 250 s:

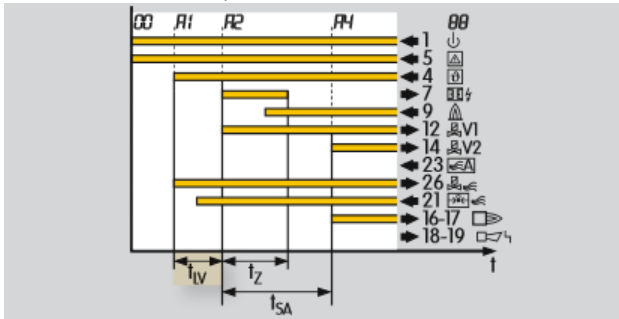

After the start-up signal (๑) has been applied and after
the flame simulation check and “no flow” state check
have been conducted successfully, the air valve is
opened. Start-up of the burner commences as usual
with no interruption of the air after expiry of the
programmable preventilation time t_{VL} .

(Parameter setting for this example sequence:
 $P15 = 1$, $P23 = 0$, $P30 = 1$, $P37 > 0$), see page 41 (Pa-
rameters). The gas valve does not open until the
pressure switch has switched.



บริษัท เอดีดี เฟอร์เนส จำกัด

ADD FURNACE CO.,LTD.

44 ซอยบรมราชชนนี 70 ถนนบรมราชชนนี แขวงศาลาธรรมสพน์ เขตทวีวัฒนา กรุงเทพฯ 10170

โทร: 02-888-3472 โทร: ออกแบบ:08-08-170-170 แฟกซ์: 02-888-3258

<https://www.add-furnace.com> E-mail: sales@add-furnace.com

Parameters

4.7.3 Air flow monitoring during operation (BCU

465..L)

Parameter 07

This parameter determines whether the air flow is monitored during operation.

Parameter 07 = 0: The air flow is not monitored during operation.

Parameter 07 = 1: The air flow is monitored during operation (pressure switch signal at terminal 21), i.e.

Check of the LOW signal (pressure switch contact open) before starting the program run

No air may flow before the program run is started. A LOW signal must be applied to the pressure switch. If the LOW signal is not applied, the BCU performs a fault lock-out after expiry of a delay time (as long as the flame simulation delay time t_{LV}). Fault message: d0, "no-flow" state check failed.

Check of the HIGH signal (pressure switch contact closed) after activating the air valve

The air must flow and a HIGH signal must be applied to the pressure switch after the air valve has been activated. If the HIGH signal is not applied within a specified testing time (as long as the safety time on start-up t_{SA}), the BCU performs a fault lock-out. Fault message: d1, no air pressure in operating state.

If the air pressure drops during operation, the BCU conducts either a fault lock-out (fault message: d4) or a restart as in the event of flame failure. Should restart fail, fault message d2 is displayed.



บริษัท เอดีดี เฟอร์เนส จำกัด

ADD FURNACE CO.,LTD.

44 ซอยบรมราชชนนี 70 ถนนบรมราชชนนี แขวงศาลาธรรมสพน์ เขตทวีวัฒนา กรุงเทพฯ 10170

โทร: 02-888-3472 โทร: ออกแบบ:08-08-170-170 แฟกซ์: 02-888-3258

<https://www.add-furnace.com> E-mail: sales@add-furnace.com

Parameters

4.7.4 Delayed air flow monitoring (BCU 465)

Parameter 08

Supplementary setting for parameter 07

Is the gas to be released with or without pressure switch signal?

Parameter 08 = 0: Gas is released only with pressure switch signal.

Parameter 08 = 1: Gas is released even without pressure switch signal. The scan is conducted after a delay time.

4.7.5 Post-ventilation time t_{NL} after a controlled shut-down (BCU 465.. .L)

Parameter 38

Value range 0–3 s

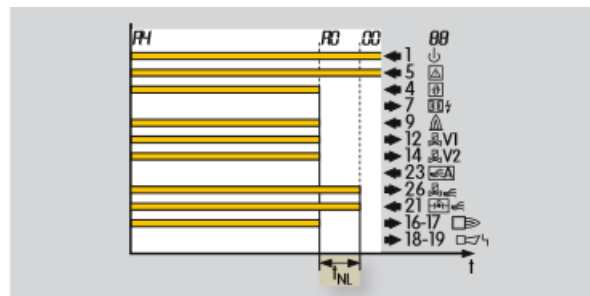

The air valve remains open for the programmed time after the start-up signal (9) has been deactivated. The burner control unit closes the air valve after expiry of the post-ventilation time t_{NL} .



บริษัท เอดีดี เฟอร์เนส จำกัด

ADD FURNACE CO.,LTD.

44 ซอยบรมราชชนนี 70 ถนนบรมราชชนนี แขวงศาลาธรรมสพน์ เขตทวีวัฒนา กรุงเทพฯ 10170

โทร: 02-888-3472 โทร: ออกแบบ:08-08-170-170 แฟกซ์: 02-888-3258

<https://www.add-furnace.com> E-mail: sales@add-furnace.com

Parameters

4.7.6 Pre-ventilation time after safety shut-down

(BCU 465..L)

Parameter 39

Value range 0 – 250 s

This can be set in 1 s steps.

This determines the time for which pre-purge is to occur after a safety shut-down.

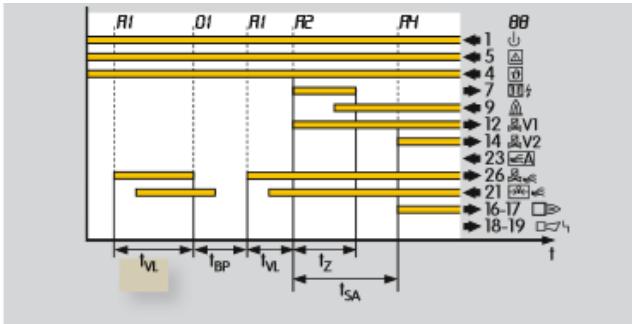

With this function, the combustion chamber can be purged after a safety shut-down in compliance with standards, especially on radiant tube burners. This task is not implemented by a central control system but by the BCU 465. See also parameters 40 and 41.

4.7.7 Pre-ventilation for restart/start-up attempts (BCU 465..L)

Parameter 40

This parameter determines whether the pre-ventilation time (parameter 39) is to run after a restart or after the start-up attempts.

Parameter 40 = 0: The pre-ventilation time is deactivated on restart and in the case of several start-up at-tempts.

Parameter 40 = 1: The pre-ventilation time is activated in the case of restart and several start-up attempts.

4.7.8 Pre-ventilation after reset (BCU 465.. .L)

Parameter 41

This parameter determines whether the pre-ventilation time (parameter 39) is to run in the case of a reset after a fault lock-out.

Parameter 41 = 0: The pre-ventilation time is deactivated after a reset.

Parameter 41 = 1: The pre-ventilation time is activated after a reset with the start-up signal (ø).



บริษัท เอดีดี เฟอร์เนส จำกัด

ADD FURNACE CO.,LTD.

44 ซอยบรมราชชนนี 70 ถนนบรมราชชนนี แขวงศาลาธรรมสพน์ เขตทวีวัฒนา กรุงเทพฯ 10170

โทร: 02-888-3472 โทร: ออกแบบ:08-08-170-170 แฟกซ์: 02-888-3258

<https://www.add-furnace.com> E-mail: sales@add-furnace.com

Parameters

4.8 Manual mode

For convenient setting of the burner or analyzing faults.

If the Reset/Information button is pressed for 2 s during switch-on, the BCU reverts to Manual mode. Two dots blink on the display.

In this operating mode, the burner control unit operates independently of the status of the inputs (apart from the pre-purge input and the safety interlocks).

Each time after the button is pressed again, the BCU moves to the next section of the program sequence and stops there. The flame signal is indicated instead of the operating status after approx. 3 s when the operating status is reached.

On units with air valve control, the air valve can be opened and closed repeatedly by pressing the button during operation.

4.8.1 Manual mode limited to 5 minutes

Parameter 34

Parameter 34 determines when Manual mode is terminated.

Parameter 34 = 0: Manual mode is not limited in time.

If this function has been selected, operation of the furnace may be continued manually in the event of failure of the central control system.

Parameter 34 = 1: Manual mode ends automatically five minutes after the last time the button was pressed. The BCU then moves abruptly back to start-up position/standby.

Manual mode can always be terminated independently of parameter 34 by switching off the BCU.



บริษัท เอดีดี เฟอร์เนส จำกัด

ADD FURNACE CO.,LTD.

44 ซอยบรมราชชนนี 70 ถนนบรมราชชนนี แขวงศาลาธรรมสพน์ เขตทวีวัฒนา กรุงเทพฯ 10170

โทร: 02-888-3472 โทร: ออกแบบ:08-08-170-170 แฟกซ์: 02-888-3258

<https://www.add-furnace.com> E-mail: sales@add-furnace.com

Selection

5 Selection

	T	-3	-5	-10	/1	/2	L	5	15	25	W	R	1	2	3	8	GB ¹⁾	P	D2	D3	S2-3	A	O ₂	U	C	B1	/1	E1
BCU 460		●	●	●	●	●	○	○	○	○	●	●	●	●	●	●	●	○	○	○	○			○	○	○	○	○
BCU 465	○	●	●	●	●	●	○	○	○	○	●	●	●	●	●	●	●	○	○	○	○	○	●	○	○	○	○	○

Order example

BCU 465-5/1LW3GBACE1

= standard, = available. ¹⁾ Not available for BCU..T. ²⁾ Only available for BCU..T.

5.Type code

Code	Description
BCU	Burner control unit
4	Series 4
60	Standard version
65	Extended air control
3; 5; 10	Safety time on start-up tsA [s]
1; 2	Safety time during operation tsB [s]
L*	Air valve control
5*; 15*; 25*	Low fire overrun time [s]
W	Mains voltage: 230 V AC, -15/+10%, 50/60 Hz
R	115 V AC, -15/+10%, 50/60 Hz
1*	Ignition transformer: TZI 5-15/100
2*	TZ I 7-25 / 20
3*	TZ I 7, 5-1 2 / 1 0 0
8*	TZI 7,5-20/33
GB*	Front film in English with additional stickers in D, F, I, NL, E
P*	Industrial plug connector
D2*	High temperature operation in conjunction with: ... UVS
D3*	..ionization sensor or UVD
S2* - 3*	Number of start-up attempts
A*	Air flow monitoring
O*	Position indicator feedback
U*	Preparation for UV sensor for continuous operation UVD 1
C*	Additional signal distribution
B1*	For PROFIBUS DP
/1*	9-pin D-Sub bus plug connector
E 1*	Power management via phase (L1)

* If "none", this specification is omitted. Please quote the default parameter settings when ordering.



บริษัท เอดีดี เฟอร์เนส จำกัด

ADD FURNACE CO.,LTD.

44 ซอยบรมราชชนนี 70 ถนนบรมราชชนนี แขวงศาลาธรรมสพน์ เขตทวีวัฒนา กรุงเทพฯ 10170

โทร: 02-888-3472 โทร: ออกแบบ:08-08-170-170 แฟกซ์: 02-888-3258

<https://www.add-furnace.com> E-mail: sales@add-furnace.com

Project planning information

6 Project planning information

6.1 Cable selection

Use mains cable suitable for the type of operation and complying with local regulations.

Signal and control line: max. 2.5 mm².

Cable for burner ground/PE wire: 4 mm².

Burner ground connector may also be located outdoors.

Do not route BCU cables in the same cable duct as frequency converter cables or cables emitting strong fields.

6.1.1 Ionization cable

Use unscreened high-voltage cable, see page 81 (Accessories).

Recommended cable length: max. 50 m.

Lay cable individually and, if possible, not in a metal conduit.

Install well away from mains cables and interference from electro-magnetic sources.

Do not lay together with ignition cable.

6.1.2 Ignition cable

Use unscreened high-voltage cable, see page 81 (Accessories).

Cable length for integrated ignition. max. 5 m (16.4 ft).

Avoid external electrical interference. The longer the ignition cable, the lower the ignition capacity.

Lay cable individually and, if possible, not in a metal conduit.

Do not lay UV/ionization cable and ignition cable together and lay them as far apart as possible.

Screw the ignition cable securely into the ignition transformer and feed it out of the unit on the shortest possible route (no loops) – use the left-hand M20 plastic cable gland.

Only use radio interference suppressed electrode plugs (with 1 kΩ resistor) for ignition electrodes, see page 81 (Accessories).

6.1.3 UV cable

Recommended cable length: max. 50 m.

Install well away from mains cables and interference from electro-magnetic sources.

Do not lay together with ignition cable.

6.2 Ignition electrode

6.2.1 Electrode distance

Gap between electrode and burner ground:
2 mm ± 0.5 mm.

6.2.2 Star electrodes

We recommend using 7.5 kV ignition transformers on burners with star electrodes.



บริษัท เอดีดี เฟอร์เนส จำกัด

ADD FURNACE CO.,LTD.

44 ซอยบรมราชชนนี 70 ถนนบรมราชชนนี แขวงศาลาธรรมสพน์ เขตทวีวัฒนา กรุงเทพฯ 10170

โทร: 02-888-3472 โทร: ออกแบบ:08-08-170-170 แฟกซ์: 02-888-3258

<https://www.add-furnace.com> E-mail: sales@add-furnace.com

Project planning information

6.3 Calculating the safety time t_{SA}

Sicherheitszeit im Anlauf
t_{SA} nach EN 746-2



D

Brennerart
Brenner mit Zwangsluft, direkt gezündet

Hauptbrennerleistung PN kW

Hauptbrenner Sicherheitszeit s

 tion 02.12 

inter
active



บริษัท เอดีดี เฟอร์เนส จำกัด

ADD FURNACE CO.,LTD.

44 ซอยบรมราชชนนี 70 ถนนบรมราชชนนี แขวงศาลาธรรมสพน์ เขตทวีวัฒนา กรุงเทพฯ 10170

โทร: 02-888-3472 โทร: ออกแบบ:08-08-170-170 แฟกซ์: 02-888-3258

https://www.add-furnace.com E-mail: sales@add-furnace.com

Project planning information

6.4 Minimum burner on time

Even if the start-up signal (9) is applied only briefly, the time set under parameter 20 elapses. The minimum burner on time t_B can be extended beyond the safety time t_{SA} to max. 25 s.

The signal input for the burner start-up signal cannot be used for a safety shut-down because the BCU controls the valves until the minimum burner on time has elapsed.

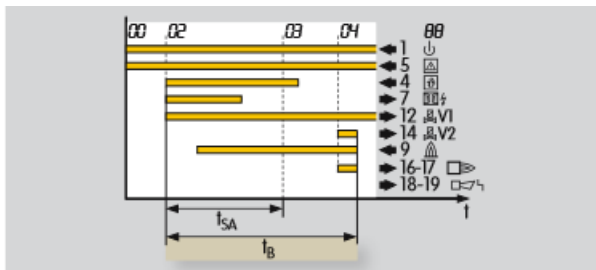

6.5 Safety interlock (Limits)

The limiters in the safety interlock (linking of all the relevant safety control and switching equipment for the use of the application, for example STL (safety temperature limiter), Gas_{min}, Gas_{max}, tightness control, pre-purge...) must isolate terminal 5 from the voltage supply. If the safety interlock is interrupted, the display shows a blinking 51 to indicate a fault.

6.6 Protection of safety-relevant outputs

When commissioning, do not switch the safety-relevant outputs to a short circuit.

Before switching on, ensure that outputs 7, 12 and 14 are not overloaded (> 3 A), using an ohmmeter, for example.

All safety-relevant outputs of the BCU are fused with an internal, replaceable fuse, see page 13 (Connection diagrams). This affects the outputs for ignition, gas valve V1 and gas valve V2.

In the event that the second internal, non-replaceable fuse for these outputs blows, the unit must be sent to the manufacturer for repair.

6.7 Emergency stop

6.7.1 In the event of fire or electric shock

If there is a risk of fire, electric shock or similar, inputs L1, N and 5 (safety interlocks) of the BCU should be disconnected from the electrical power supply – this should be reflected in the wiring on site.

6.7.2 Triggered by the safety interlock (limits)

The safety interlock turns off the power to the input 5, such as in the event of low air pressure or similar.



บริษัท เอดีดี เฟอร์เนส จำกัด

ADD FURNACE CO.,LTD.

44 ซอยบรมราชชนนี 70 ถนนบรมราชชนนี แขวงศาลาธรรมสพน์ เขตทวีวัฒนา กรุงเทพฯ 10170

โทร: 02-888-3472 โทร: ออกแบบ:08-08-170-170 แฟกซ์: 02-888-3258

<https://www.add-furnace.com> E-mail: sales@add-furnace.com

Project planning information

6.8 Reset

6.8.1 Parallel reset

Several automatic burner control units can be reset in parallel using an external button. The BCU cannot be reset by mains failure.

6.8.2 Permanent remote reset

Permanent remote reset gives rise to a malfunction. If a remote reset signal is permanently applied to terminal 3, 52 flashes on the display to indicate a fault.

Reset with a pulse < 1 s.

6.8.3 Automatic remote reset (PLC)

In the case of automatic remote reset (PLC), the reset pulse duration should not exceed 1 second. Check compliance with Standards.

If a fault is acknowledged by remote reset too often, error 10 (Too many remote resets) is displayed. The error can only be acknowledged with the Reset/Information button on the unit.

The burner malfunction must be remedied. The malfunction cannot be remedied by changing the method of activation.

6.9 Burner start

A furnace start may only be initiated, if it has been ensured using an appropriate procedure that there is no combustible mixture in the combustion/processing chamber, in the connected areas or in the exhaust gas system (heat exchanger, dust collector). This can be achieved by pre-purge, which occurs immediately before ignition or within the period specified in the operating instructions.

In the case of multiple burner applications, pre-purge is not necessary after a controlled burner shut-down.

Note the requirements of the Standards. For exceptions, see Standards.

6.10 Restart and start-up attempts

The precondition for a restart/start-up attempt is that activation of the restart allows the burner to restart as intended (in all operating phases). In this case, it must be ensured that the program sequence started by the BCU matches the application.

In accordance with EN 746-2, a maximum of three start-ups are permitted in specific cases if the safety of the installation is not impaired. Note the requirements of the Standards!



บริษัท เอดีดี เฟอร์เนส จำกัด

ADD FURNACE CO.,LTD.

44 ซอยบรมราชชนนี 70 ถนนบรมราชชนนี แขวงศาลาธรรมสพน์ เขตทวีวัฒนา กรุงเทพฯ 10170

โทร: 02-888-3472 โทร: ออกแบบ:08-08-170-170 แฟกซ์: 02-888-3258

<https://www.add-furnace.com> E-mail: sales@add-furnace.com

Project planning information

6.11 Fault signaling

The fault signalling contact opens, as soon as the mains voltage fails.

6.12 Overload protection

To protect the unit against overload by frequent cycling, the BCU may not start up more than n times per minute. Excessive cycling triggers a fault message (flashing 53). The max. number (n) per minute depends on the safety time tSA and the ignition transformer used.

tSA s	Ignition transformer TZI	Max. number n/min.
3	5-15/100	6
5	5-15/100	6
10	5-15/100	3
3	7-25/20	3
5	7-25/20	2
10	7-25/20	1
3	7,5-12/100	6
5	7,5-12/100	4
10	7,5-12/100	2
3	7,5-20/33	4
5	7,5-20/33	3
10	7,5-20/33	2

6.13 Installation

Recommended installation position: vertical (cable glands pointing downwards).

When installing, ensure that there is sufficient space to open the BCU.

From inside

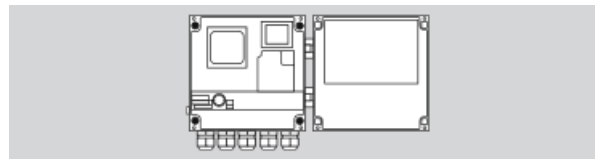

Open BCU and screw on with four screws (Ø 4 mm, min. length 15 mm).

From outside

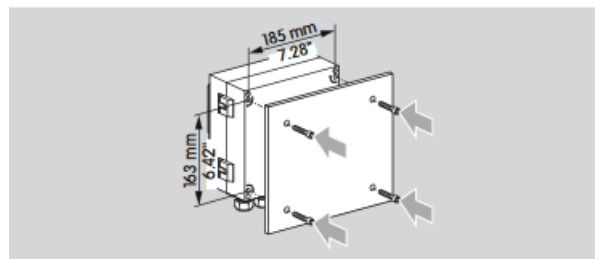

Screw on the closed unit to the rear with 4 self-tapping screws (enclosed).

Otherwise, mount with external securing bars or the fastening set, see page 81 (Accessories).



บริษัท เอดีดี เฟอร์เนส จำกัด

ADD FURNACE CO.,LTD.

44 ซอยบรมราชชนนี 70 ถนนบรมราชชนนี แขวงศาลาธรรมสพน์ เขตทวีวัฒนา กรุงเทพฯ 10170

โทร: 02-888-3472 โทร: ออกแบบ:08-08-170-170 แฟกซ์: 02-888-3258

<https://www.add-furnace.com> E-mail: sales@add-furnace.com

Project planning information

6.14 Wiring

The BCU is suitable for hard wiring only. Do not reverse phase and neutral conductor. Different phases of a three-phase current system must not be installed at the BCU.

No voltage may be connected to the valve and ignition outputs.

No gas valve may be connected to the air valve output (terminal 26).

See page 13 (Connection diagrams) onwards.

6.15 BCU and BCU..E1 (with and without adapted power management)

The BCU is available as a replacement unit for existing systems in which a BCU is already in operation.

We recommend using a BCU with power management (BCU..E1) when planning new systems. It features a new power management scheme for simplified installation and control. The power for the ignition transformer and valves is supplied via the phase (terminal 1) and must no longer be supplied by the safety interlocks. No effort and expenditure is thus required for coupling contactors and their safety devices.

Unit replacement

A BCU without power management may not be replaced with a BCU with power management

(BCU..E1). The reverse also applies, i.e. a BCU..E1 may not be re-placed with a BCU without power management.

6.16 Signal distributor board

An additional signal distributor board (terminals 30–38) can be ordered for wiring additional relays, etc.

(BCU..C).

Protecting the control with an additional fuse F3 makes troubleshooting easier in the event of a short-circuit downstream of the pressure switch.

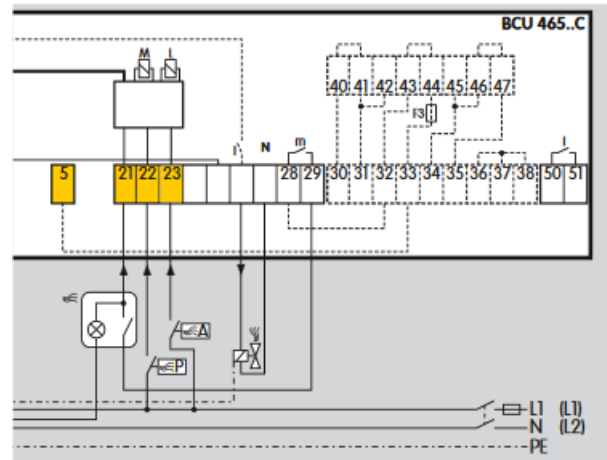



บริษัท เอดีดี เฟอร์เนส จำกัด

ADD FURNACE CO.,LTD.

44 ซอยบรมราชชนนี 70 ถนนบรมราชชนนี แขวงศาลาธรรมสพน์ เขตทวีวัฒนา กรุงเทพฯ 10170

โทร: 02-888-3472 โทร: ออกแบบ:08-08-170-170 แฟกซ์: 02-888-3258

<https://www.add-furnace.com> E-mail: sales@add-furnace.com

Project planning information

6.17 PROFIBUS DP

6.17.1 Safety-related control signals

Signals from the safety interlocks and digital input are transferred independently of the bus communication by separate cables.

The purge signals can be transferred via the bus communication or by a separate cable.

6.17.2 Wiring the PROFIBUS plug connector

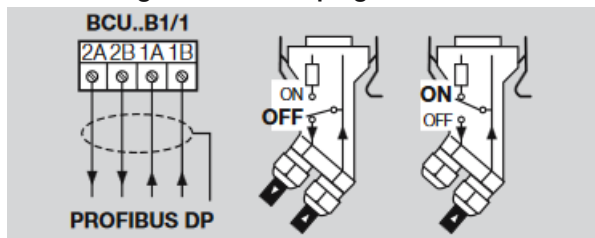

The PROFIBUS plug connector must be ordered separately, see page 81 (Accessories).

Data cables A and B must not be reversed.

The power supply for the bus terminator is provided by the BCU. The bus terminator can be connected in the PROFIBUS plug connector.

Project planning information

6.17.5 Status and fault messages for PROFIBUS DP

This table can be used to program the master.

Ensure an equipotential bond between the different slaves and masters.

6.17.3 EMC

To achieve a high immunity of the system against electromagnetic interference radiation, a shielded data cable must be used. The shield must be connected to protective earth on both sides using wide-area shield clips that ensure good conductivity.

In addition, it must be ensured that all cables leading to and from the BCU® be installed as far away as possible from cables emitting strong fields (e.g. frequency converter cables).

6.17.4 Unit replacement

A BCU..B1 (for PROFIBUS) may only be replaced by a BCU..B1. BCUs without a PROFIBUS connection may not be replaced by a BCU..B1.



บริษัท เอดีดี เฟอร์เนส จำกัด

ADD FURNACE CO.,LTD.

44 ซอยบรมราชชนนี 70 ถนนบรมราชชนนี แขวงศาลาธรรมสพน์ เขตทวีวัฒนา กรุงเทพฯ 10170

โทร: 02-888-3472 โทร: ออกแบบ:08-08-170-170 แฟกซ์: 02-888-3258

https://www.add-furnace.com E-mail: sales@add-furnace.com

Project planning information

Input bytes (BCU → master)					
Byte 2	Display	Status signal Byte 0, Bit 2 = 0	Fault signal Byte 0, Bit 2 = 1	BCU460..B1	BCU465..B1
7			Fault Position indicator during flame proving period		●
7			Fault Air supply during flame proving period		●
8	 	Operation, main burner	Flame failure during main burner operation		
8			Fault Position indicator during operation		●
8			Fault Air supply during operation		●
9		Purge		○	●
9			Fault Air supply during purging		●
10			Too many remote resets	●	●
11			Fault Air supply during pre-ventilation		●
12			Fault Air supply during post-ventilation		●
30		EEPROM data change, NFS**		●	●
31		EEPROM data change, FS**		●	●
33		Faulty parameterization		●	●
51		Fuse F1 defective or safety interlocks discontinuity		●	●
52		Permanent remote reset		●	●
53		Timing cycle too short		●	●
99			Internal error/negative flame current	●	●

* Display on BCU..L upon activation of the air valve during program step x

** FS = input/output, safety circuit, NFS = input/output, control system

● = standard, ○ = available



บริษัท เอดีดี เฟอร์เนส จำกัด

ADD FURNACE CO.,LTD.

44 ซอยบรมราชชนนี 70 ถนนบรมราชชนนี แขวงศาลาธรรมสพน์ เขตทวีวัฒนา กรุงเทพฯ 10170

โทร: 02-888-3472 โทร: ออกแบบ:08-08-170-170 แฟกซ์: 02-888-3258

<https://www.add-furnace.com> E-mail: sales@add-furnace.com

Project planning information

6.18 Third gas valve (can be shut down) on BCU

460..L and BCU 465

Units with air valve control have an additional contact (terminal 50/51), which closes at the same time as the air valve.

This can be used to activate a third gas valve. To do this, the output of valve V1 or V2 must be used as auxiliary energy (as a result of the required flame monitoring).

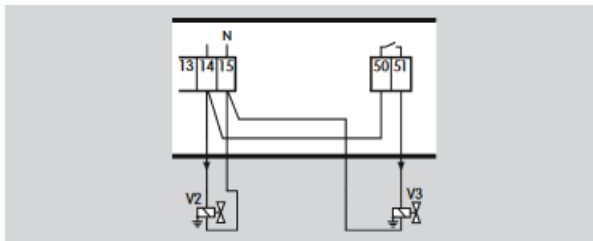

The following application describes a two-stage-controlled burner without a pneumatic air/gas ratio control system. V2 and the air valve are activated simultaneously.

However, V2 may not be activated during purging.

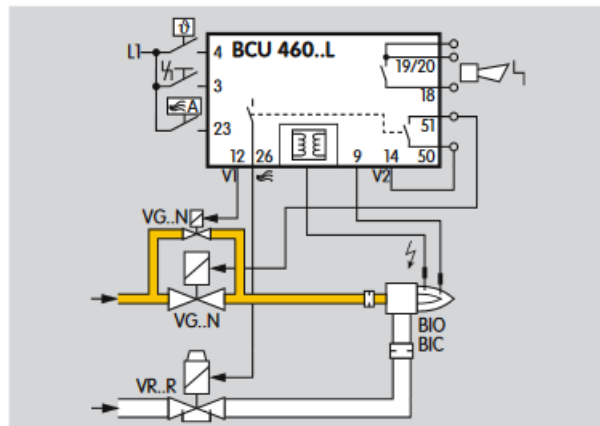



บริษัท เอดีดี เฟอร์เนส จำกัด

ADD FURNACE CO.,LTD.

44 ซอยบรมราชชนนี 70 ถนนบรมราชชนนี แขวงศาลาธรรมสพน์ เขตทวีวัฒนา กรุงเทพฯ 10170

โทร: 02-888-3472 โทร: ออกแบบ:08-08-170-170 แฟกซ์: 02-888-3258

<https://www.add-furnace.com> E-mail: sales@add-furnace.com

Project planning information

6.19 BCU switched off

In general, the BCU cannot be activated when no mains voltage is applied or the burner control unit is switched off.

The fault signalling contact is only closed when the unit is supplied with voltage and switched on.

6.20 Note on EC-type examination

Since EN 298 (1993) does not describe all functions of the BCU, the operator is responsible for ensuring that all parameters and functions are matched to the respective application.

6.21 Mains switch

The mains switch in the unit isolates the BCU on two poles from the mains. It does not meet the requirements of EN 50156-1:2004 (5.2.2 Disconnecting switch) set out in chapter 5 for a device to disconnect the power supply.

Although the mains switch cannot be used for disconnecting from the electrical power supply in accordance with EN 50156, it does allow the burner to be isolated functionally from the central control system. This function is required for manual operation and, in the case of PROFIBUS units, to switch off the unit without causing bus errors.

Disconnection for electrical maintenance work is to be implemented with an external switch per unit or group only, in accordance with Standard EN 50156.

6.22 SIL/PL level for thermoprocessing equipment

Since thermoprocessing installations include different safety functions, it is not possible to determine a single SIL/PL level for an entire installation, but this must be determined separately for every safety function of the installation.

See also page 86 (Safety-specific characteristic values).



บริษัท เอดีดี เฟอร์เนส จำกัด

ADD FURNACE CO.,LTD.

44 ซอยบรมราชชนนี 70 ถนนบรมราชชนนี แขวงศาลาธรรมสพน์ เขตทวีวัฒนา กรุงเทพฯ 10170

โทร: 02-888-3472 โทร: ออกแบบ:08-08-170-170 แฟกซ์: 02-888-3258

<https://www.add-furnace.com> E-mail: sales@add-furnace.com

Project planning information

6.23 Changing parameters

In certain cases, it may be necessary to change the default settings. Using a separate software package and a PC optoadapter, it is possible to modify certain parameters on the BCU, such as the switch-off threshold of the flame amplifier, the behaviour in the event of a flame failure or whether the pilot burner is to burn permanently in the case of pilot and main burner monitoring.

The software package with PC optoadapter, as well as "Changed parameters" stickers, are available as accessories – see page 81 (Accessories).

The unit parameters set at the factory are specified in the enclosed delivery note.

Document changed parameters in BCSoft using the protocol function and enclose the protocol with the plant documentation.

If a replacement is ordered for a BCU with changed parameters, refer to the protocol for details.



บริษัท เอดีดี เฟอร์เนส จำกัด

ADD FURNACE CO.,LTD.

44 ซอยบรมราชชนนี 70 ถนนบรมราชชนนี แขวงศาลาธรรมสพน์ เขตทวีวัฒนา กรุงเทพฯ 10170

โทร: 02-888-3472 โทร: ออกแบบ:08-08-170-170 แฟกซ์: 02-888-3258

<https://www.add-furnace.com> E-mail: sales@add-furnace.com

Flame control

7 Flame control

7.1 With ionization sensor

The BCU generates an alternating voltage (230 V AC) between the sensing electrode and burner ground. The flame rectifies this voltage. Only the DC signal ($> 1 \mu\text{A}$) is detected by the burner control unit.

A flame cannot be simulated.

Ignition and monitoring with a single electrode is possible.

7.2 With UV sensor

A UV tube inside the UV sensor detects the ultraviolet light of a flame. It does not respond to sunlight, incandescent bulb light or infrared radiation emitted by hot workpieces or red-hot furnace walls.

In the event of incident UV radiation, the UV sensor rectifies the supplied alternating voltage. As with ionization control, the burner control unit only detects this DC signal.

When using UV sensors of Type UVS, the burner control unit may be used for intermittent operation only. This means that operation must be interrupted at least once every 24 hours. This can be programmed by setting parameter 35 to 1.

Further information can be found in brochure UVS at www.docuthek.com.

The burner control unit BCU..U is prepared for UV sensor UVD 1. This enables continuous operation. For flame control with UVD sensor, safety-specific characteristic values are available for the Safety Integrity Level SIL.

Further information can be found in TI UVD 1 at www.docuthek.com.



บริษัท เอดีดี เฟอร์เนส จำกัด

ADD FURNACE CO.,LTD.

44 ซอยบรมราชชนนี 70 ถนนบรมราชชนนี แขวงศาลาธรรมสพน์ เขตทวีวัฒนา กรุงเทพฯ 10170

โทร: 02-888-3472 โทร: ออกแบบ:08-08-170-170 แฟกซ์: 02-888-3258

<https://www.add-furnace.com> E-mail: sales@add-furnace.com

Flame control

7.3 Via the temperature in high temperature equipment

High temperature equipment is defined as a thermo-processing installation, in which the wall temperature of the combustion chamber and/or the processing chamber exceeds 750°C.

Burner control units BCU..D2 and BCU..D3 feature a special "High temperature operation" function, see page 44 (High temperature operation in the case of BCU..D2 or BCU..D3).

During heating up, standard monitoring methods (ionization or UV) must be used for flame control. When the working temperature has exceeded 750°C, indirect flame control can be taken over by a central monitoring device. When the DI input (terminal 6) is activated, the burner control unit reverts to this operating mode.

Important: in "High temperature operation" (HT operation), i.e. with the DI input being activated, burner control units BCU..D2 (D3) do not evaluate the flame signal. The safety function of the burner control unit's flame control is deactivated during this operating phase.



บริษัท เอดีดี เฟอร์เนส จำกัด

ADD FURNACE CO.,LTD.

44 ซอยบรมราชชนนี 70 ถนนบรมราชชนนี แขวงศาลาธรรมสพน์ เขตทวีวัฒนา กรุงเทพฯ 10170

โทร: 02-888-3472 โทร: ออกแบบ:08-08-170-170 แฟกซ์: 02-888-3258

<https://www.add-furnace.com> E-mail: sales@add-furnace.com

Accessories

8 Accessories

8.1 High-voltage cable

FZLSi 1/7 up to 180°C,

Order No.: 04250410.

FZLK 1/7 up to 80°C,

Order No.: 04250409.

8.2 Industrial plug connector, 16-pin



Order No.: 74919469

8.3 PROFIBUS plug connector

Variosub PROFIBUS plug connector, 9-pin, with deactivatable bus terminator, Order No.: 74960431

GSD files for BCU Profibus DP on BCSoft CD-ROM, Order No. 74960436, or at www.docuthek.com



Bibliography

- PROFIBUS Specification, EN 50170 Vol. 2 (version 1.0).
- Installation Guideline for PROFIBUS DP/FMS, available from the Profibus User Organization (PUO).
- PROFIBUS Technology and Application, Order No.: 4.001, available from the PUO.
- M. Popp, The New Rapid Way to PROFIBUS DP, a textbook for system operators.
- M. Popp, PROFIBUS DP Principles, Tips and Tricks for Users.
- www.profibus.com



บริษัท เอดีดี เฟอร์เนส จำกัด

ADD FURNACE CO.,LTD.

44 ซอยบรมราชชนนี 70 ถนนบรมราชชนนี แขวงศาลาธรรมสพน์ เขตทวีวัฒนา กรุงเทพฯ 10170

โทร: 02-888-3472 โทร: ออกแบบ:08-08-170-170 แฟกซ์: 02-888-3258

<https://www.add-furnace.com> E-mail: sales@add-furnace.com

Accessories

8.4 BCSoft

The current software can be downloaded from our Internet site at <http://www.docuthek.com>. To do so, you need to register in the DOCUTHEK.

8.4.1 Opto-adapter



With USB interface, cable length 3 m, including BCSoft CD-ROM.

Order No.: 74960437.

8.5 “Changed parameters” stickers

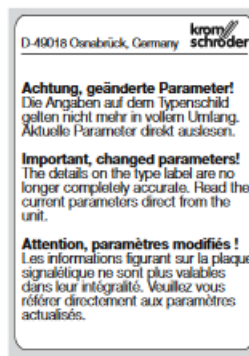

Affix on the connection diagram of the BCU following changes to unit parameters set at the factory.

100 pcs,
Order No.: 74921492.



บริษัท เอดีดี เฟอร์เนส จำกัด

ADD FURNACE CO.,LTD.

44 ซอยบรมราชชนนี 70 ถนนบรมราชชนนี แขวงศาลาธรรมสพน์ เขตทวีวัฒนา กรุงเทพฯ 10170

โทร: 02-888-3472 โทร: ออกแบบ:08-08-170-170 แฟกซ์: 02-888-3258

<https://www.add-furnace.com> E-mail: sales@add-furnace.com

Accessories

8.6 External securing bar

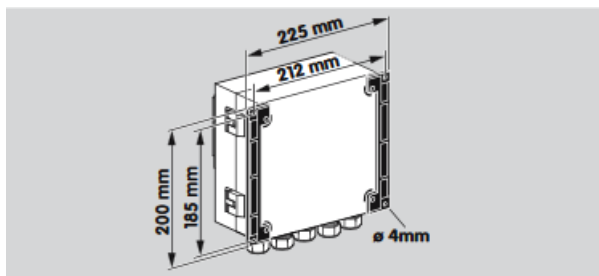

Order No.: 74960414

8.7 Fastening set

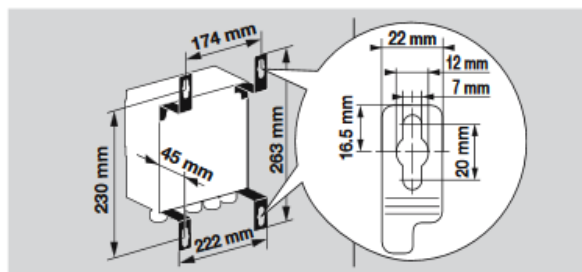

Order No.: 74960422

8.8 Radio interference suppressed electrode plugs

Angle plug, 4 mm, interference-suppressed, Order No. 04115308. Straight plug, 4 mm, interference-suppressed, Order No. 04115307. Straight plug, 6 mm, interference-suppressed, Order No. 04115306.



บริษัท เอดีดี เฟอร์เนส จำกัด

ADD FURNACE CO.,LTD.

44 ซอยบรมราชชนนี 70 ถนนบรมราชชนนี แขวงศาลาธรรมสพน์ เขตทวีวัฒนา กรุงเทพฯ 10170

โทร: 02-888-3472 โทร: ออกแบบ:08-08-170-170 แฟกซ์: 02-888-3258

<https://www.add-furnace.com> E-mail: sales@add-furnace.com

Technical data

9 Technical data

Mains voltage:

230 V AC, -15/+10%, 50/60 Hz,

115 V AC, -15/+10%, 50/60 Hz

For grounded and ungrounded mains.

Inherent consumption: approx. 9 VA plus inherent consumption of the integrated ignition transformer.

Voltage to inputs and valves = mains voltage.

Signal and control line: max. 2.5 mm².

Cable for burner ground/PE wire: 4 mm².

Cable gland:

5 cable glands with multiple seal inserts for cable diameters of up to 7 mm,

BCU..P: with 2 cable glands with multiple seal inserts for 4 cables of up to 7 mm in diameter and an industrial chassis plug. Each BCU is supplied for two cable glands with one seal insert each for cable diameters between 7 and 12 mm.

Input voltage of signal inputs:

	115 V AC	230 V AC
Signal "1"	80–126.5	160–253
Signal "0"	0–20	0–40

Input current of signal inputs:

Signal "1": typ. 2 mA

Output current:

max. 1 A, $\cos \phi = 1$, for the valve outputs (or SRC out-puts),

but total current for valves and ignition transformer: max. 2.5 A.

Fail-safe inputs and outputs:

All the inputs and outputs marked "■" (see page 13 (Connection diagrams)) may be used for safety tasks.

Flame control with UV detector or ionization sensor.

Flame signal for

ionization control: 1 – 28 μ A,

UV control: 1 – 35 μ A.

For intermittent or continuous operation.

Maximum length of ignition cable with integrated elec-tronic ignition: 5 m (16.4 ft).

Maximum length of ionization/UV cable: 50 m (164 ft).



บริษัท เอดีดี เฟอร์เนส จำกัด

ADD FURNACE CO.,LTD.

44 ซอยบรมราชชนนี 70 ถนนบรมราชชนนี แขวงศาลาธรรมสพน์ เขตทวีวัฒนา กรุงเทพฯ 10170

โทร: 02-888-3472 โทร: ออกแบบ:08-08-170-170 แฟกซ์: 02-888-3258

<https://www.add-furnace.com> E-mail: sales@add-furnace.com

Technical data

Fuses in unit:

F1: 3.15 A, slow-acting, H, pursuant to IEC 127-2/5. Fuse for protecting the safety-relevant ignition, valve 1, valve 2 and air valve outputs (terminals 7, 12, 14 and 26): 5 A, slow-acting, not replaceable.

F3 (only for BCU.. A, BCU..C and BCU..U):

3.15 A, slow-acting, H, pursuant to IEC 127-2/5.

Operation and fault signalling contacts:

Signalling contact for mains voltage, max. 2 A, 253 V, not internally fused.

Number of operating cycles:

Relay outputs: 250,000 pursuant to EN 298,

Mains switch: 1,000,

Reset/Information button: 1,000.

Ambient temperature:

-20 to +60°C,

no condensation permitted.

Enclosure: IP 54 pursuant to IEC 529.

Weight: approx. 5 kg depending on version.

Ignition transformer	Input			Output	
	V AC	Hz*	A*	V	mA*
TZI 5-15/100W	230	50 (60)	0.45 (0.35)	5000	15 (11)
TZI 7-25/20W	230	50 (60)	1.1 (0.8)	7000	25 (18)
TZI 7,5-12/100W	230	50 (60)	0.6 (0.45)	7500	12 (9)
TZI 7,5-20/33W	230	50 (60)	0.9 (0.7)	7500	20 (15)
TZI 5-15/100R	115	50 (60)	0.9 (0.7)	5000	15 (11)
TZI 7-25/20R	115	50 (60)	2.2 (1.6)	7000	25 (18)
TZI 7,5-12/100R	115	50 (60)	1.2 (0.9)	7500	12 (9)
TZI 7,5-20/33R	115	50 (60)	1.8 (1.35)	7500	20 (15)

* Values in () apply to 60 Hz.

9.1 BCU..B1

External fuse: 12 A per zone.

9.2 PROFIBUS DP

Manufacturer ID: 0x05DB.

ASIC type: SPC3.

SYNC- and FREEZE-capable.

Baud rate detection: automatic.

Min. cycle time: 0.1 ms.

Diagnostic bytes: 6 (DP Standard).

Parameter bytes: 7 (DP Standard).



บริษัท เอดีดี เฟอร์เนส จำกัด

ADD FURNACE CO.,LTD.

44 ซอยบรมราชชนนี 70 ถนนบรมราชชนนี แขวงศาลาธรรมสพน์ เขตทวีวัฒนา กรุงเทพฯ 10170

โทร: 02-888-3472 โทร: ออกแบบ:08-08-170-170 แฟกซ์: 02-888-3258

<https://www.add-furnace.com> E-mail: sales@add-furnace.com

Technical data

9.3 Safety-specific characteristic values

In the case of ionization control, suitable for Safety Integrity Level	SIL 3
Diagnostic coverage DC	92.7%
Type of subsystem	Type B to EN 61508-2, 7.4.3.1.4
Mode of operation	High demand mode pursuant to EN 61508-4, 3.5.12
Mean probability of dangerous failure PFH _D	$1.92 \times 10^{-8} 1/h$
Mean time to dangerous failure MTF _d	$MTF_d = 1 / PFH_D$
Safe failure fraction SFF	98.8%

The specified values apply for the combination with ionization electrode (sensor) and a unit of the BCU 400 series.

No characteristic values are available for flame control with UVS sensor.

For flame control with UVD sensor, safety-specific characteristic values are available for the Safety Integrity Level SIL. Further information can be found in TI UVD 1 at www.docuthek.com.

Relationship between the Performance Level (PL) and the Safety Integrity Level (SIL)

PL	SIL
a	-
b	1
c	1
d	2
e	3

Pursuant to EN ISO 13849-1:2006, Table 4, the BCU can be used up to PL e.

Max. service life under operating conditions: 20 years after date of production.

For a glossary of terms, see page 89 (Glossary). For further information on SIL/PL, see www.k-sil.de



บริษัท เอดีดี เฟอร์เนส จำกัด

ADD FURNACE CO.,LTD.

44 ซอยบรมราชชนนี 70 ถนนบรมราชชนนี แขวงศาลาธรรมสพน์ เขตทวีวัฒนา กรุงเทพฯ 10170

โทร: 02-888-3472 โทร: ออกแบบ:08-08-170-170 แฟกซ์: 02-888-3258

https://www.add-furnace.com E-mail: sales@add-furnace.com

Technical data

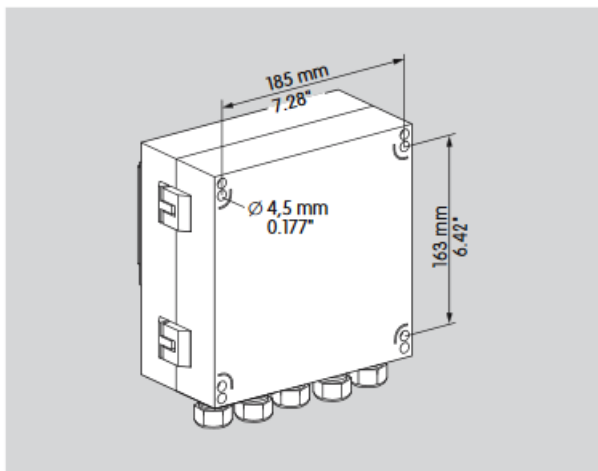
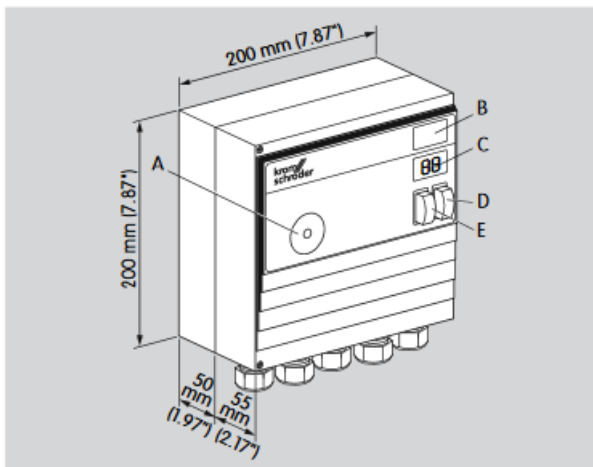

Die-cast aluminium housing with plug-in terminal blocks and plug-in M20 cable glands or (16-pin) plug connector for input signals and optionally pre-assembled cables for output signals.

9.4 Control elements

- A: Optical interface.
- B: Labelling field for individual labelling of the system components.
- C: 2-digit 7-segment display.
- D: Mains switch to isolate the BCU on two poles from the mains.
- E: Reset/Information button to reset the system after a fault or to scan parameters on the display.

9.5 Installation

Recommended installation position: vertical (cable glands pointing downwards).

Open the BCU and attach with four screws 4 mm or screw on the closed unit using the external securing bar, see page 81 (Accessories).

Electrical connection via plug-in connection terminals (2.5 mm²) and plug-in cable glands. The latter can be removed in order to facilitate installation. When installing, ensure that there is sufficient space to open the BCU.



บริษัท เอดีดี เฟอร์เนส จำกัด

ADD FURNACE CO.,LTD.

44 ซอยบรมราชชนนี 70 ถนนบรมราชชนนี แขวงศาลาธรรมสพน์ เขตทวีวัฒนา กรุงเทพฯ 10170

โทร: 02-888-3472 โทร: ออกแบบ:08-08-170-170 แฟกซ์: 02-888-3258

<https://www.add-furnace.com> E-mail: sales@add-furnace.com

Legend

	Display
	Blinking display
	Ready
	Safety interlocks (Limits)
	Start-up signal
	Digital input
	Ignition transformer
	Gas valve
	Air valve
	Purge
	Ext. air valve control
	Flame signal
	Operating signal
	Fault signal
	Reset
	Input signal
	Output signal
	Flame simulation check
t_W	Waiting time ≥ 2 s
t_{SA}	Safety time on start-up 3 s, 5 s or 10 s
t_{SB}	Safety time during operation < 1 s or < 2 s
t_Z	Ignition time 2 s, 3 s or 6 s
t_{LV}	Flame simulation delay time 25 s
t_{FS}	Flame proving period 0 – 25 s

	Air pressure switch (electrical connection)
	Air pressure switch
t_B	Minimum burner on time t_{SA} up to max. 25 s
t_{BP}	Minimum burner pause time 0 – 25 s
t_{KN}	Low fire over-run time 0 s, 5 s, 15 s or 25 s
t_{VL}	Pre-ventilation time 0 – 250 s
t_{NI}	Post-ventilation time 0 – 3 s
	Input/Output, safety circuit



บริษัท เอดีดี เฟอร์เนส จำกัด

ADD FURNACE CO.,LTD.

44 ซอยบรมราชชนนี 70 ถนนบรมราชชนนี แขวงศาลาธรรมสพน์ เขตทวีวัฒนา กรุงเทพฯ 10170

โทร: 02-888-3472 โทร: ออกแบบ:08-08-170-170 แฟกซ์: 02-888-3258

<https://www.add-furnace.com> E-mail: sales@add-furnace.com

Glossary

11 Glossary

11.1 Waiting time t_W

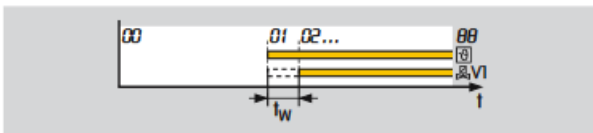

Once the start-up signal ๑ has been applied, the waiting time t_W starts to elapse. During this time, a self-test is conducted to detect errors in internal and external circuit components. If no malfunction is detected, the burner will start up.

11.2 Safety time on start-up t_{SA}

This refers to the period of time between switching on and switching off of the gas valve, when no flame signal is detected. The safety time on start-up t_{SA} (3, 5 or 10 s) is the minimum operating time of the burner and burner control unit.

11.3 Ignition time t_Z

If no malfunction is detected during the waiting time t_W , the ignition time t_Z then starts to elapse. Voltage is supplied to the pilot gas valve V1 and the ignition transformer and the burner is ignited. The duration of the ignition time is either 2, 3 or 7 seconds (depending on safety time t_{SA} selected).

11.4 Flame simulation/Flame simulation delay time t_{LV}

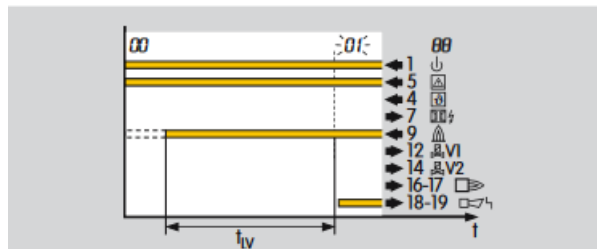

An extraneous signal (flame simulation) is a flame signal that is detected, although there should be no flame according to the program sequence. If such an extraneous signal is detected, the flame simulation delay time t_{LV} starts to elapse. If the flame simulation is discontinued during the flame simulation delay time t_{LV} , start-up can be initiated or operation continued. Otherwise, a fault lock-out occurs.



บริษัท เอดีดี เฟอร์เนส จำกัด

ADD FURNACE CO.,LTD.

44 ซอยบรมราชชนนี 70 ถนนบรมราชชนนี แขวงศาลาธรรมสพน์ เขตทวีวัฒนา กรุงเทพฯ 10170

โทร: 02-888-3472 โทร: ออกแบบ:08-08-170-170 แฟกซ์: 02-888-3258

https://www.add-furnace.com E-mail: sales@add-furnace.com

Glossary

11.5 Safety time during operation t_{SB}

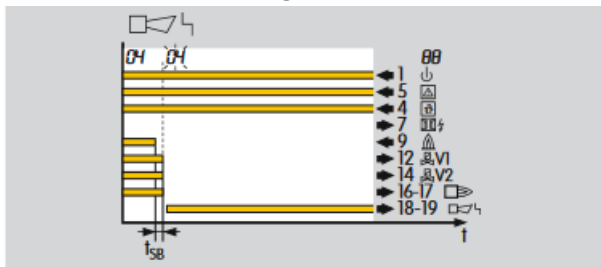

If the flame fails during operation, the valve outputs are disconnected within the safety time t_{SB} .

The default safety time during operation t_{SB} in accordance with EN 298 is 1 second. In accordance with EN 746-2, the safety time of the installation during operation (including closing time of the valves) may not exceed 3 s.

Note the requirements of the Standards!

11.6 Flame signal

If a flame is detected, the flame detector will supply a flame signal.

11.7 Fault lock-out

In the event of a fault lock-out, all valves and the ignition transformer are disconnected from the electrical power supply, and a fault is signalled. Resetting must take place manually following a fault lock-out.

11.8 Safety interlocks (Limits)

The limiters in the safety interlock (linking of all the relevant safety control and switching equipment for the use of the application, e.g. safety temperature limiter, minimum/maximum gas pressure) must isolate input  from the voltage supply.

11.9 Pilot gas valve V1

The start fuel flow rate for the burner is released by pilot gas valve V1. It opens when the safety time on start-up t_{SA} starts to elapse. It remains open until the burner is switched off again by a controlled shut-down or fault lock-out.

11.10 Main gas valve V2

Once the safety time on start-up t_{SA} has elapsed, the main gas valve V2 is opened. It remains open until the burner is switched off or a fault is signalled.

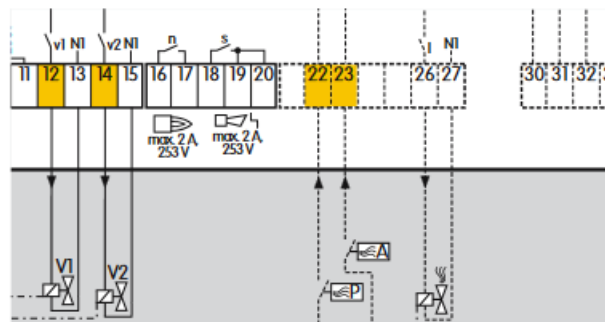



บริษัท เอดีดี เฟอร์เนส จำกัด

ADD FURNACE CO.,LTD.

44 ซอยบรมราชชนนี 70 ถนนบรมราชชนนี แขวงศาลาธรรมสพน์ เขตทวีวัฒนา กรุงเทพฯ 10170

โทร: 02-888-3472 โทร: ออกแบบ:08-08-170-170 แฟกซ์: 02-888-3258

<https://www.add-furnace.com> E-mail: sales@add-furnace.com

Glossary

11.11 Continuous operation

The gas burner runs continuously for more than 24 hours.

11.12 Air valve

The air valve can be used

- for cooling,
- for purging,
- to control the burner capacity in ON/OFF mode and in High/Low mode when using a pneumatic air/gas ratio control system.

11.13 Diagnostic coverage DC

Measure of the effectiveness of diagnostics, which may be determined as the ratio between the failure rate of detected dangerous failures and the failure rate of total dangerous failures

NOTE: Diagnostic coverage can exist for the whole or parts of a safety-related system. For example, diagnostic coverage could exist for sensors and/or logic system and/or final elements. Unit: %.

from EN ISO 13849-1:2008

11.14 Mode of operation

High demand mode or continuous mode

Operating mode, where the frequency of demands for operation made on a safety-related system is greater than one per year or greater than twice the proof-test frequency

from EN 61508-4:2001

11.15 Safe failure fraction SFF

Fraction of safe failures related to all failures, which are assumed to appear

from EN 13611/A2:2011

11.16 Probability of dangerous failure PFHD

Value describing the likelihood of dangerous failure per hour of a component for high demand mode or con-tinuous mode. Unit: 1/h.

from EN 13611/A2:2011

11.17 Mean time to dangerous failure

MTTF_d

Expectation of the mean time to dangerous failure

from EN ISO 13849-1:2008