



บริษัท เอดีดี เฟอร์เนส จำกัด

**ADD FURNACE CO.,LTD.**

44 ซอยบรมราชชนนี 70 ถนนบรมราชชนนี แขวงศาลาธรรมสพน์ เขตทวีวัฒนา กรุงเทพฯ 10170

โทร: 02-888-3472 โทร: ออกแบบ:08-08-170-170 แฟกซ์: 02-888-3258

<https://www.add-furnace.com> E-mail: [sales@add-furnace.com](mailto:sales@add-furnace.com)

# krom schroder

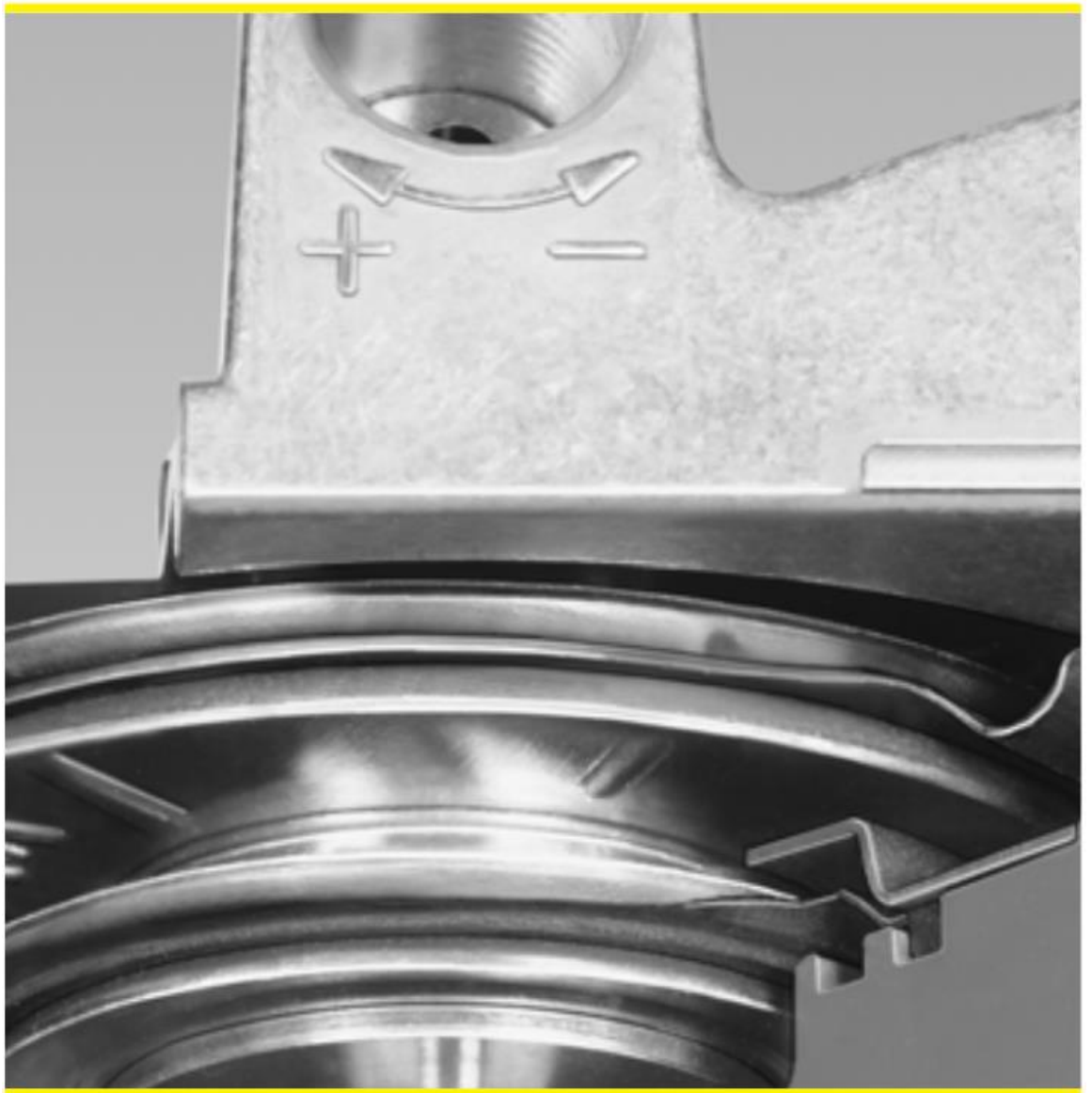

**Combination controls**

**CG 10**





### Combination controls CG 10

- // Complete with strainer, two solenoid valves and servo-governor for maximum regulation precision.
- // Special low-noise valves.
- // Optional pressure switch at the inlet.
- // Easy-to-service. All adjustment and metering facilities, with the addition of the electrical connections, are accessible from one side.
- // Flow rate adjustment for precise adjustment of the max. flow rate.
- // Environment-friendly thanks to recyclable and resource-friendly design, plastic parts with material identification.
- // EC type-tested and certified design.
- // CE



### Application

For safeguarding and controlling atmospheric burners, forced draught gas burners and induced-draught boilers on heating installations up to 50 kW. Combination controls CG..G, CG..V2 and CG..V3 can also be used on steam boiler installations to TRD 412. The combination controls are EC type-tested and certified pursuant to the Gas Appliance Directive (90/396/EEC) in conjunction with EN 126.

### Examples of application

**CG..D1**  
**CG..D2**  
Single-stage, special-purpose gas heating boilers, single-stage wall heating boilers, pre-mixers.

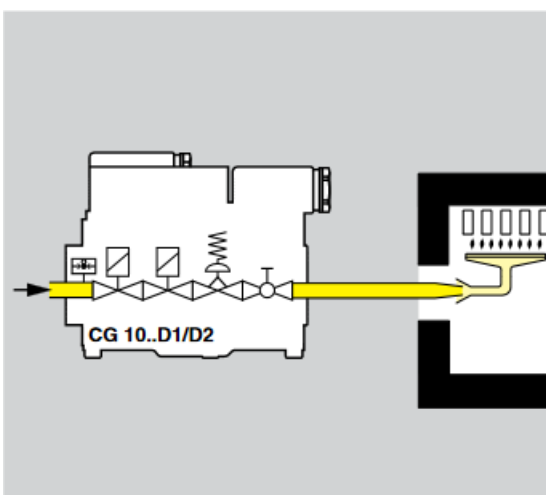

**CG..D1**  
**CG..D2**  
*Hearths.*

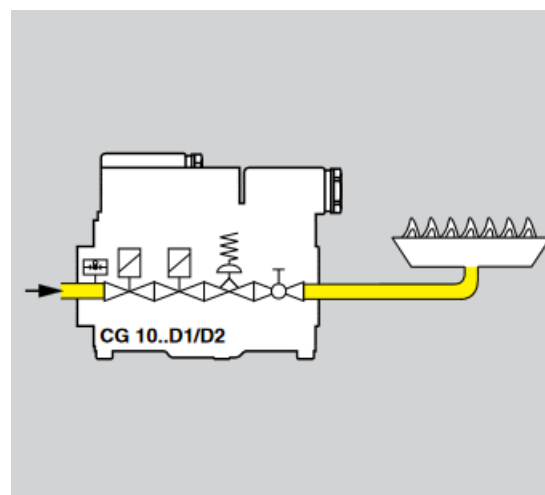

**CG..D1**  
**CG..D2**  
Units, single-stage forced draught gas burners, burners with mechanical capacity adjustment

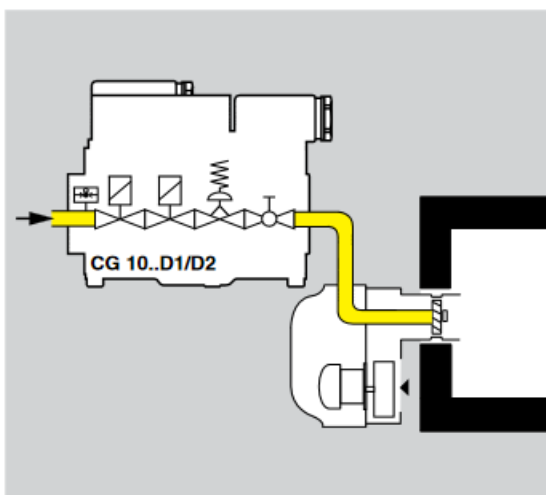

**CG..G\***  
Draught-assisted boilers, modulating or multi-stage control.

**CG..V**  
Fan and draught-assisted boilers, modulating or two-stage control

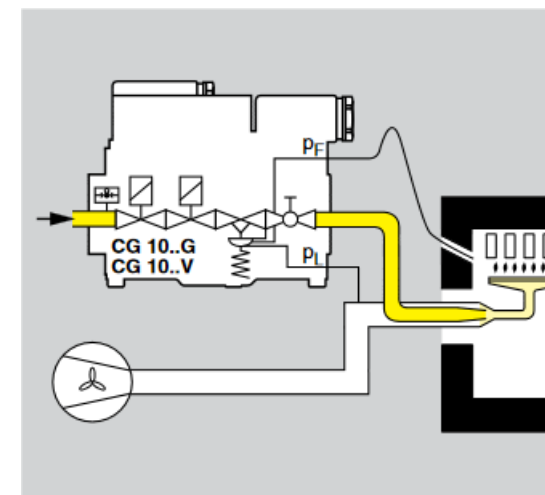

**CG..D1**  
**CG..D2**  
Radiant plaques, industrial heating systems, radiant tube heaters, space heaters.

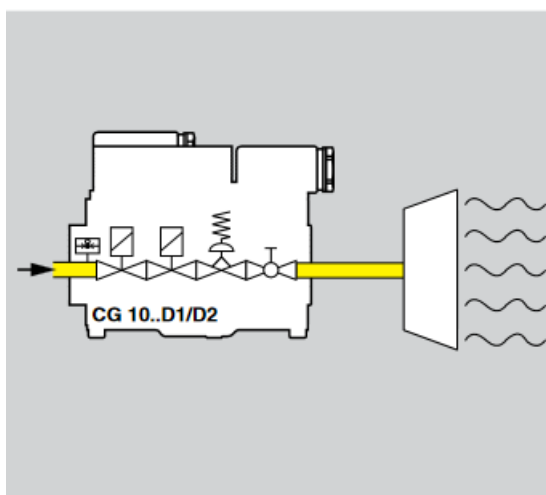

**CG..G\***  
Boilers with flue-gas, induced-draught fan.

**CG..V**  
Boilers with flue-gas induced-draught fan.

\*CG..G without connection for combustion chamber pressure pF

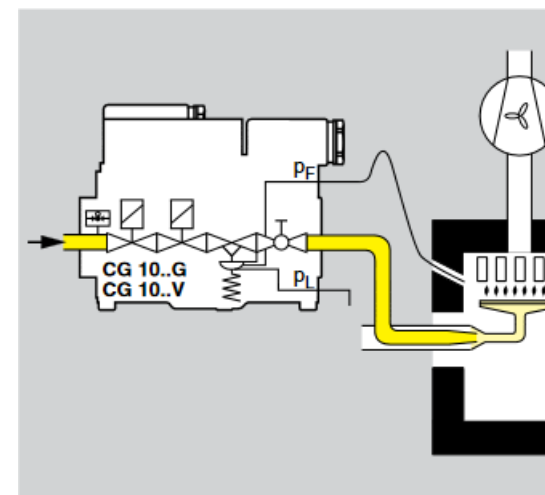



**CG..G\***

Forced draught burners, modulating or two-stage control.

**CG..V**

Forced draught burners, modulating or multi-stage control.

\* CG..G without connection for combustion chamber pressure pF

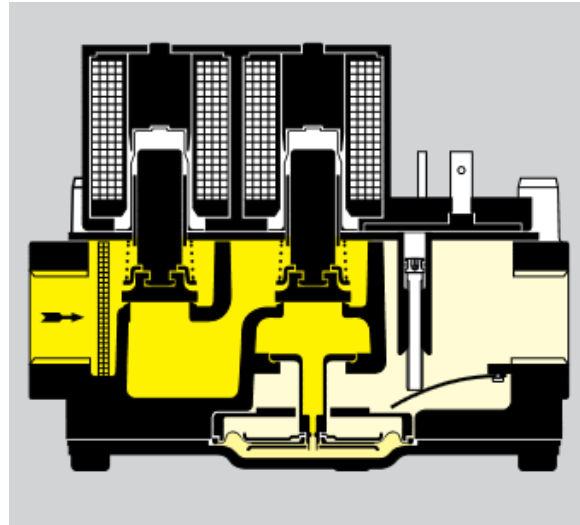
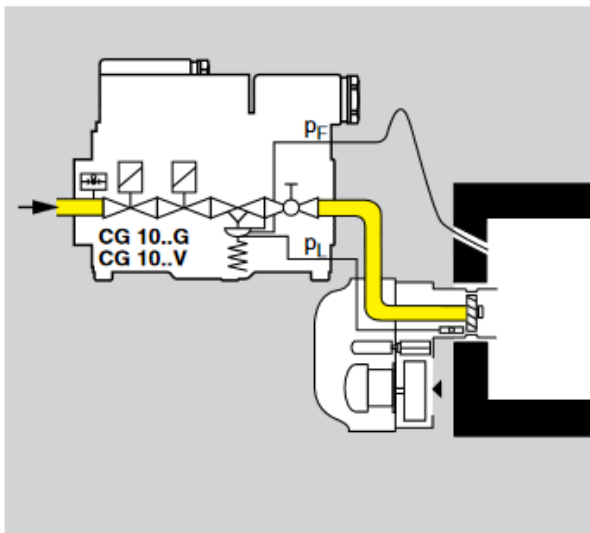

**Function**

When the voltage is applied, the two solenoid valves open. The servo-governor achieves a high regulating precision regardless of changing inlet pressures.

**Features**

- 2 solenoid valves, class A or B.
- CG..D1 with constant pressure governor.
- CG..D2 with constant pressure governor with start load.
- CG..G with air/gas ratio control, ratio of

**Technical data**

Types of gas: natural gas and LPG (gaseous).  
 Inlet pressure range  $p_e$ : 15 to 70 mbar.  
 Ambient temperature: 0 to +70°C.  
 Storage temperature: -20 to +50°C.  
 Threaded connection: Rp 1/2 in accordance with ISO 7-1.  
 Threaded connection, control lines pL, pF: Rp 1/8 (CG..G, CG..V2 and CG..V3 only)  
 Pressure test points on inlet and outlet.  
 Housing components: AISi.  
 Diaphragms: Perbunan.  
 Strainer: plastic fabric.  
 Solenoid valves (class A or B) with spring-loaded valve disc, normally closed (when de-energised).  
 Switching frequency: any.  
 Closing time: <1 s.

- gas pressure to air pressure 1:1.
- CG..V2 and CG..V3 with variable air/gas ratio control, ratio of gas pressure to air pressure 2:1 or 3:1.
- Inlet pressure switch DG..C can be fitted at the works (cannot be fitted retrospectively).
- With flow rate adjustment.

**Mains voltage:**

230 V, -15/+10 %, 50/60 Hz,  $\cos \varphi = 1$   
 206 V, -15/+10 %, DC voltage  
 24 V, ±15 %, 50/60 Hz,  $\cos \varphi = 1$   
 20 V, ±15 %, DC voltage.

**Power consumption:**

A valves: 24 W  
 B valves: 18 W

The electrical power is the same when switching on as in continuous operation.

Duty cycle: 100 % duty.

Protective grade IP 54 in accordance with IEC 529.

Fusing: max. 6.3 A, slow-blowing.

Electrical connection:

Coupler plug in accordance with ISO 4400 with cable gland: Pg 11.

**Fitting position**

In vertical pipework: as required;  
 in horizontal pipework: inclined up to max. 90° to left/right, not upside-down, see also CG..D2: Function.

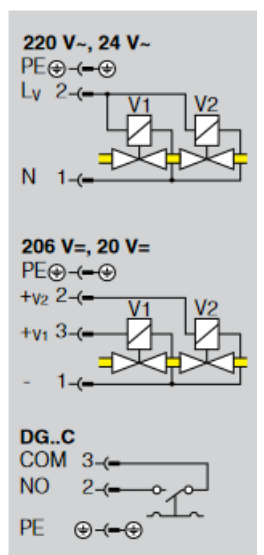

Type	Connection	Dimensions							$p_e$ max.	P	Weight
		DN	L	H1*	H2	H3	B1	B2			
CG 10..A	Rp 1/2	15	116	74	64	33	30	63	70	24	1.4
CG 10..B	Rp 1/2	15	116	59	64	33	30	63	70	18	1.2

\* with rectifier adapter + 22 mm

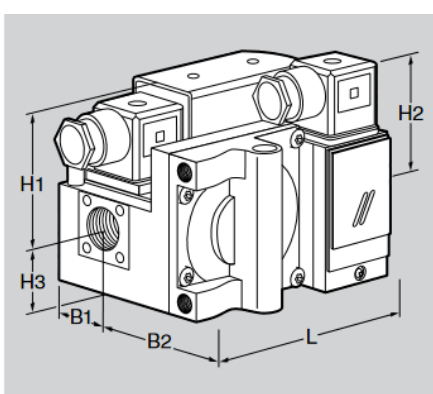



### CG..D1, CG..D2

With constant governor, class C, for high regulating precision, for atmospheric burners or single-stage forced draught gas burners.

**Function:** Both valves open when the voltage is applied.

CG..D1: The outlet pressure rises to  $p_G$ .

CG..D2: The outlet pressure initially rises to the start pressure  $p_S$ . This is then followed by a damped pressure rise to  $p_G$ .

In fitting position "governor pointing downwards", the pressure remains constant for max. 6 sec. when the start pressure  $p_S$  is reached. Only then does a damped pressure rise to  $p_G$  occur.

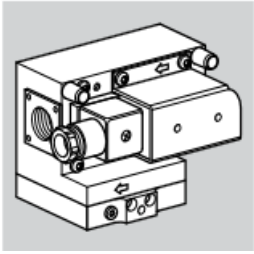

#### Working range:

CG..D1: The outlet pressure  $p_G$  can be adjusted by means of a spring from 5 to 40 mbar (CG..D1-20: 2.5-20 mbar).

CG..D2: The start pressure  $p_S$  can be adjusted from 2 to 15 mbar; the outlet pressure  $p_G$  can be adjusted from 5 to 40 mbar (CG..D2-20:  $p_S$ : 1-7.5 mbar,  $p_G$ : 2.5-20 mbar).

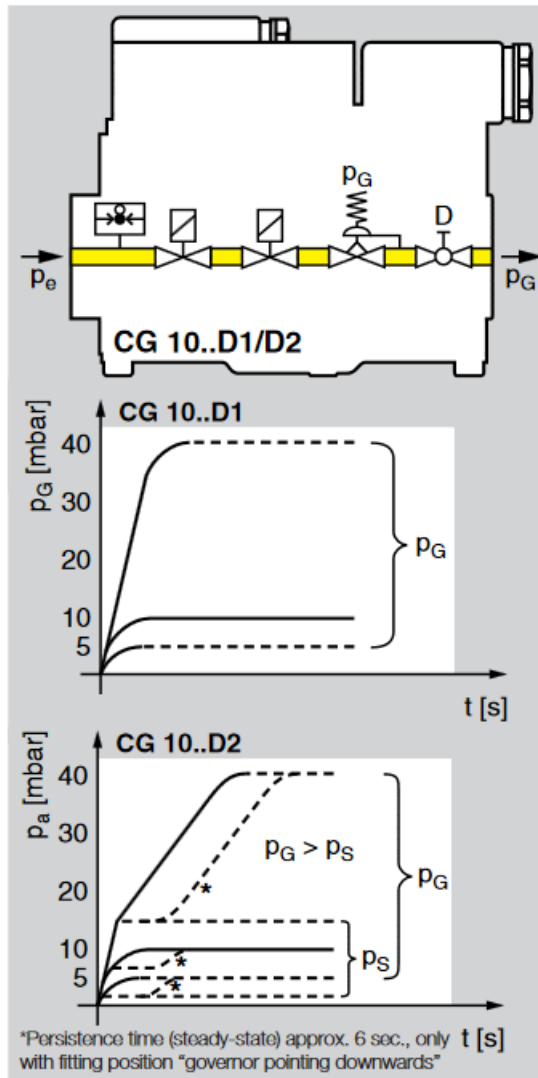

### CG..G, CG..V2 and CG..V3

With constant governor or variable air/gas ratio control, class C, for precise pneumatic air/gas ratio control for modulating or two-stage, sliding draught burners or draught-assisted boilers.

**Function:** Both valves open when the voltage is applied. The CG then regulates the gas outlet pressure  $p_G$ . This pressure follows the variable air control pressure  $p_L$ . The ratio between gas and air pressure remains constant.

At min.-flow operation of the burner, the gas/air mixture can be varied through parallel shifting of the characteristic by adjusting the screw "N". High fire is adjusted with the main flow restrictor D. On the CG..V2 and CG..V3, the combustion chamber pressure can be compensated for by connection to  $p_F$ .

#### Working range:

Permitted gas outlet pressure:

$p_G = 0.4$  to 30 mbar.

Permitted air control pressure:

$p_L = 0.4$  to 10 mbar.

Zero offset N:

CG..G:  $\pm 0.2$  mbar

CG..V2:  $\pm 0.4$  mbar

CG..V3:  $\pm 0.6$  mbar

Gas/air ratios:

CG..G: approx. 1:1

CG..V2: approx. 2:1

CG..V3: approx. 3:1

Permitted combustion chamber pressure:

$p_F = -2$  to  $+5$  mbar.

Minimum control pressure difference:

$p_L - p_F = 0.4$  mbar.

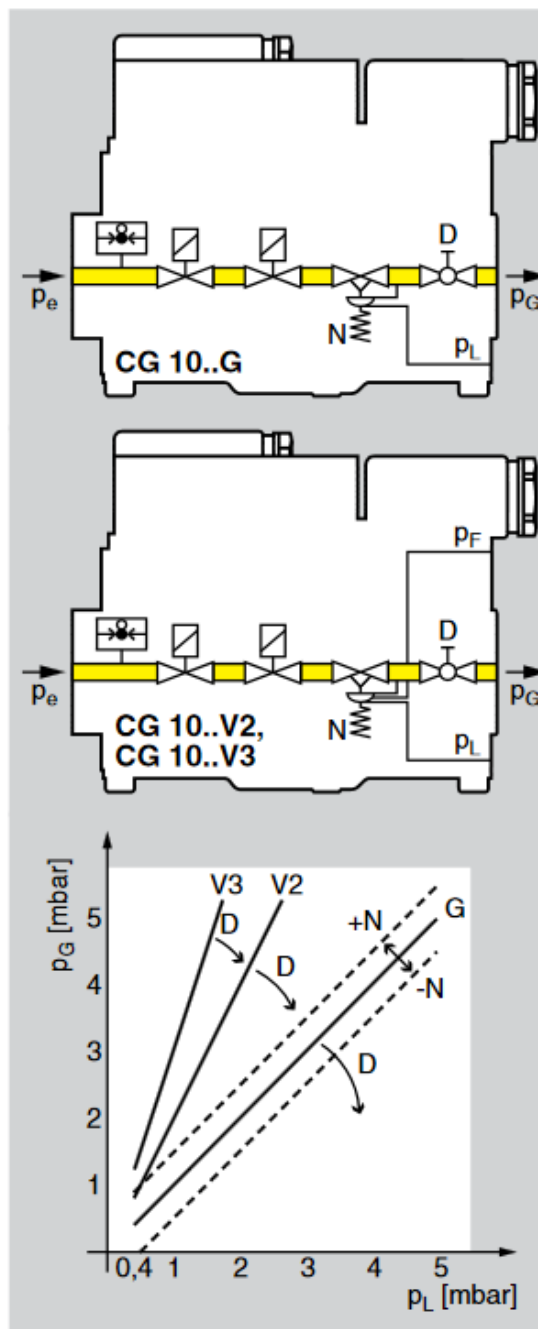



### Selection examples

Outlet data:

Type of gas: natural gas

Min. inlet pressure  $p_e$ : 18 mbar

Max. flow rate  $V'$  max.: 12 m<sup>3</sup>/h

Max. outlet pressure  $p_G$ : 10 mbar

### CG..D1, CG..D2

The pressure drop  $\Delta p$  across the entire combination control can be calculated as follows:

$$\Delta p = p_e - p_G$$

$$= 18 - 10 \text{ mbar}$$

$$= 8 \text{ mbar}$$

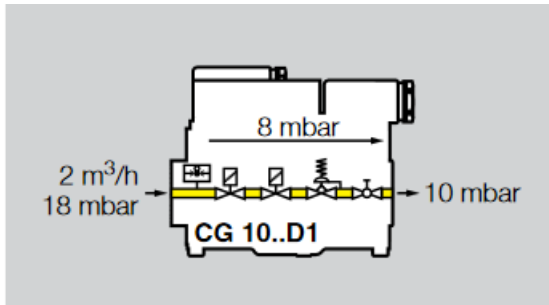

The operating point P1 ( $V'$  max. = 2 m<sup>3</sup>/h;  $\Delta p$  = 8 mbar) must lie in the working range of the combination control CG 10.

### CG..G, CG..V2, CG..V3

Additional outlet data

Max. burner air pressure  $p_L$ : 4 mbar

$$U = \frac{p_G}{p_L} = \frac{10}{4} = 2,5$$

Select the governor type with the next higher ratio  $U_{min}$ .

Governor "G" →  $U_{min.} = 1.9$  ( $U_{max.} = 1$ )

Governor "V2" →  $U_{min.} = 1.9$  ( $U_{max.} = 2.3$ )

Governor "V3" →  $U_{min.} = 2.9$  ( $U_{max.} = 3.5$ )

The available pressure drop  $\Delta p$  can be calculated as follows:

$$\Delta p = p_e - U_{max.} \cdot p_L = 18 - 3,5 \cdot 4 \text{ mbar} = 4 \text{ mbar}$$

The operating point P2 ( $V'$  max. = 2 m<sup>3</sup>/h;  $\Delta p$  = 4 mbar) must lie in the working range of the combination control CG 10.

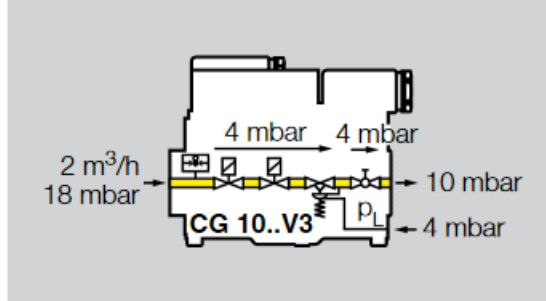

A further 4 mbar must be generated by flow rate adjustment, in addition to the computed pressure drop  $\Delta p = 4$  mbar, in order to achieve the required outlet pressure  $p_G = 10$  mbar.

At min. flow, the actual flow rate may not drop below the minimum flow rate  $V'_{min.}$  (see diagram).

### All GC units

If the operating point does not lie in the working range of the CG 10, the inlet variables  $p_e$ ,  $V'$ ,  $p_G$  or  $p_L$  must be adapted. We recommend a different CG control for

applications with different capacity demand. See also CG 1, 2, 3, Brochure No. 5.1.2.2.

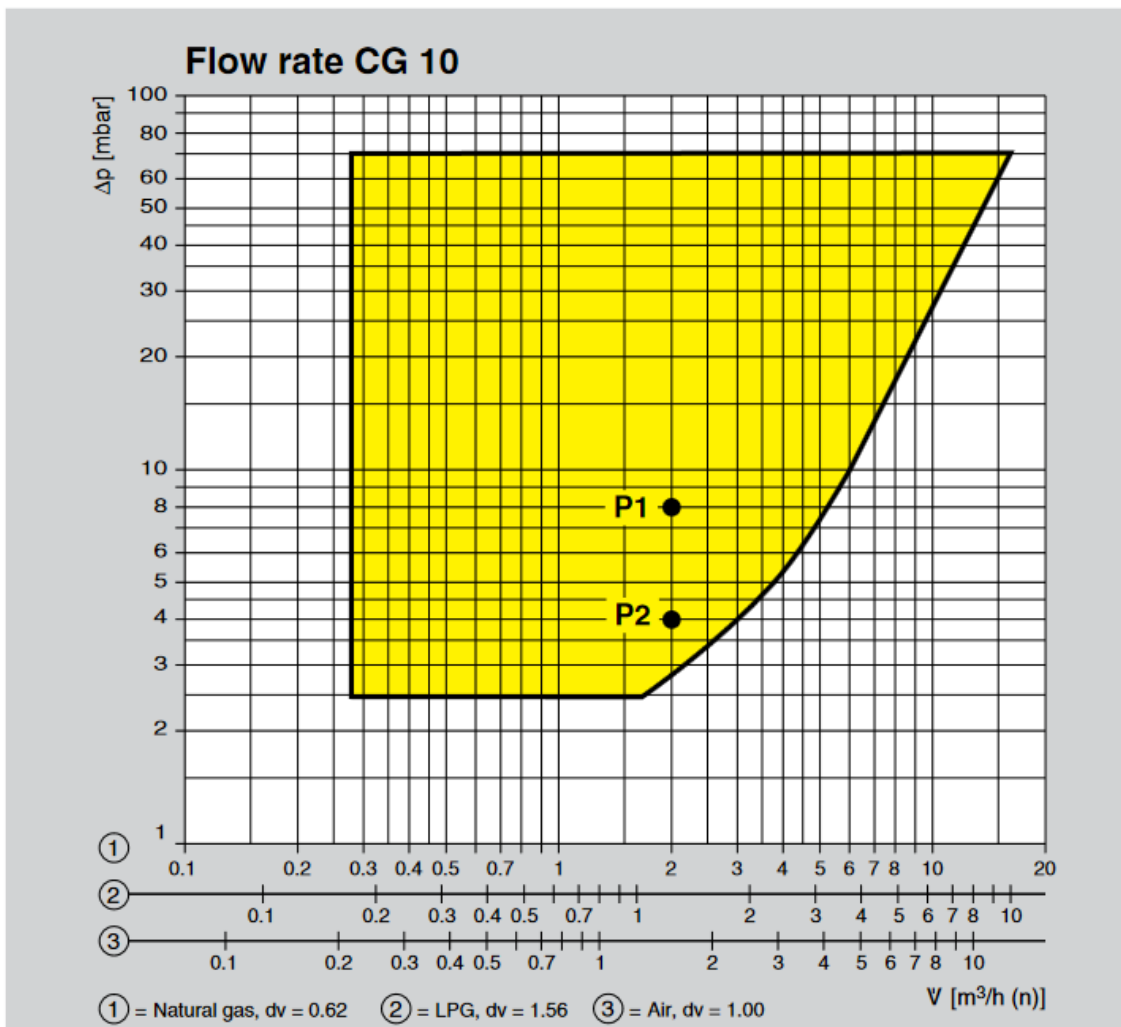



บริษัท เอดีดี เฟอร์เนส จำกัด

ADD FURNACE CO.,LTD.

44 ซอยบรมราชชนนี 70 ถนนบรมราชชนนี แขวงศาลาธรรมสพน์ เขตทวีวัฒนา กรุงเทพฯ 10170

โทร: 02-888-3472 โทร: ออกแบบ:08-08-170-170 แฟกซ์: 02-888-3258

https://www.add-furnace.com E-mail: [sales@add-furnace.com](mailto:sales@add-furnace.com)



### Accessories

Combination control CG 10 can be fitted at the works with a preset pressure switch for gas DG..C at the inlet as a low-pressure gas cut-out.  
Pre-setting: 14 mbar.

Electrical connection: coupler plug in accordance with ISO 4400 with cable gland Pg 11.  
Flanges DN 15, straight version or angle version available.  
Both a rectifier adapter for interconnection and a coupler plug with rectifier are available for AC voltage.

### Type code

Type	CG	10	R	70	-D1-20*	W	6	A	W**	Z**
Size	10									
Rp thread	Rp 1/2"									
Max. inlet pressure pe	70 mbar = 70									
Governor = D1	Governor with start gas stage = D2									
Air/gas ratio control = G	Variable air/gas-ratio control 2:1 = V2									
Variable air/gas-ratio control 2:1 = V2	Variable air/gas-ratio control 3:1 = V3									
Variable air/gas-ratio control 3:1 = V3	Max. outlet pressure pG with D1 and D2: 20 mbar = 20*									
Max. outlet pressure pG with D1 and D2: 20 mbar = 20*	Mains voltage 20 V= = L									
Mains voltage 20 V= = L	24 V~ = H									
24 V~ = H	206 V= = U									
206 V= = U	230 V~ = W									
230 V~ = W	Rectifier adapter without socket = 5									
Rectifier adapter without socket = 5	Rectifier adapter with socket = 6									
Rectifier adapter with socket = 6	Without rectifier, without socket = 8									
Without rectifier, without socket = 8	Without rectifier, with socket = 9									
Without rectifier, with socket = 9	Valve class = A, B									
Valve class = A, B	Pressure switch DG 35C = W*, DG 45/VC = WV**									
Pressure switch DG 35C = W*, DG 45/VC = WV**	Special version = Z**									

\* pG = 40 mbar if "none".

\*\* This letter is omitted if "none".