



Magnetic relief valve VAN

Technical Information · GB

3 Edition 05.17

- Openwhende-energized
- Connection flanges for pipes up to DN 50
- Suitable for a maximum inlet pressure of 500 mbar (7 psig)
- Space-saving installation thanks to compact dimensions
- Quick closing, quick opening
- Check indication by blue LED
- Closed position switch with visual position indicator



Contents

Magnetic relief valve VAN	1
Contents ..	2
1 Application ..	3
1.1 Application examples	5
1.1.1 Relief valve with two gas solenoid valves and tightness control	5
1.1.2 Relief valve with 2 gas solenoid valves	5
1.1.3 Inert gas atmosphere for annealing processes	5
2 Certification ..	6
3 Function ..	7
3.1 Magnetic relief valve VAN	7
3.2 Magnetic relief valve VAN..S, VAN..G	7
3.3 Animation	8
3.4 Connection diagram	9
3.4.1 VAN with M20 cable gland	9
3.4.2 VAN with plug	9
3.4.3 VAN..S, VAN..G with closed position switch and visual position indicator	9
4 Replacement possibilities	10
4.1 Search for order number or type	10
5 Flow rate ..	11
5.1 Calculating the nominal size	11
6 Selection ..	12

6.1 Selection table	12
6.1.1 Type code	12
7 Project planning information ..	13
7.1 Installation	13
7.1.1 Relief line for the NAFTA market	14
8 Accessories ..	15
8.1 Exhaust ABG	15
8.1.1 Installation instructions	15
8.1.2 Selection	16
8.1.3 Technical data	16
8.2 Relief line adapter	17
8.3 Intermediate elements for VCS 1 – 3	17
8.4 Seal set VA 1 – 2	18
8.5 Pressure switch for gas	18
8.5.1 DG..VC for VAN 1/VAN 2	18
8.5.2 DG..VCT for VAN 1..T/VAN 2..T	19
8.5.3 DG..C fastening set for VAX 1 – 3	19
9 Technical data ..	20
9.1 Dimensions	21
9.1.1 VAN with Rp internal thread [mm]	21
9.1.2 VAN with NPT internal thread [inch]	21
Feedback ..	22
Contact ..	22

1 Application



The magnetic relief valve VAN is designed to monitor gas valves for tightness used in conjunction with a visual discharge unit. It enables the purging of excess or leakage gas. The magnetic relief valve VAN is open when it is de-energized.

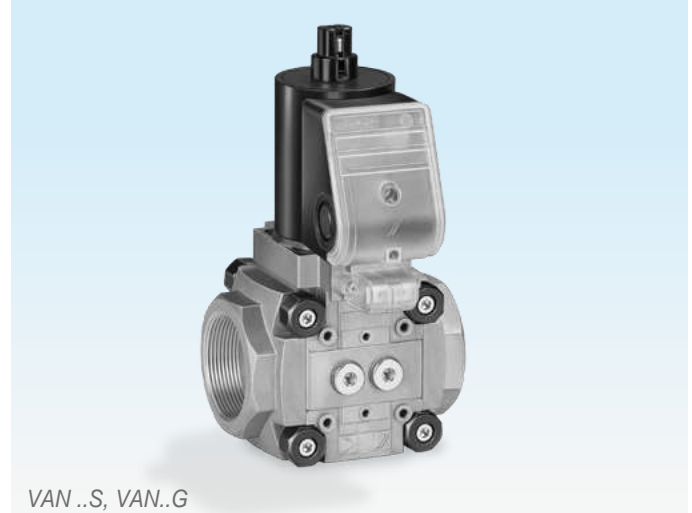

The VAN..S, VAN..G is fitted with a closed position switch with a visual position indicator. It is indicated whether the magnetic relief valve is open or closed.



Forging furnace



Roller hearth furnace



Magnetic relief valve VAV on the double solenoid valve VCS

1.1 Application examples

1.1.1 Relief valve with two gas solenoid valves and tightness control

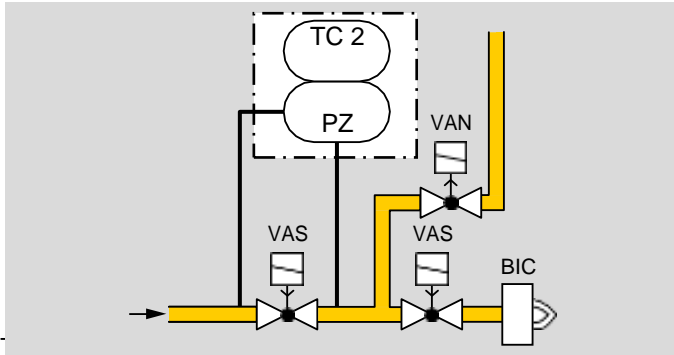

and the magnetic relief valve VAN for tightness.

If the gas solenoid valves and the magnetic relief valve are tight, the tightness control forwards an enable signal to the automatic burner control unit. The pilot valve output of the automatic burner control unit opens the gas solenoid valves VAS simultaneously. The burner starts.

In accordance with the Russian safety regulations PB 12-529-03, installations with a capacity of ≥ 1.2 MW must be fitted with a relief valve and tightness control.

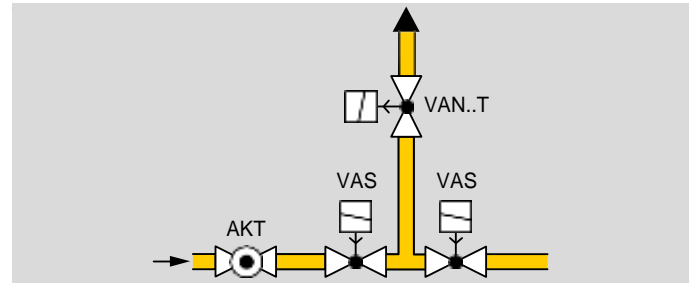

A valve, open when de-energized, is designed to purge gas to a safe venting point.

For the NAFTA market, this applies for capacities of ≥ 117 kW (400,000 BTU/h), see page 14 (Relief line for the NAFTA market).

1.1.3 Inert gas atmosphere for annealing processes

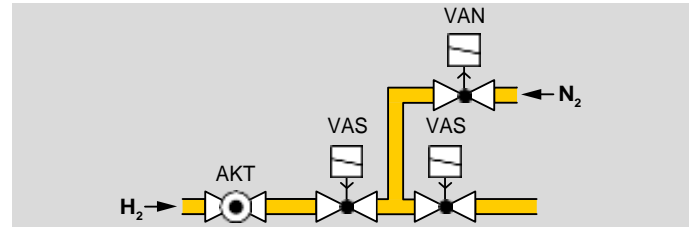

Whenever no hydrogen is needed for the annealing process (e.g. in the case of an annealing bell), the gas solenoid valves VAS and the magnetic relief valve VAN are disconnected from the electrical power supply. The VAN opens. Under high pressure, nitrogen can now get between the two gas solenoid valves VAS. This prevents hydrogen from flowing into the furnace.

2 Certification

Certificates – see www.docuthek.com

EU certified pursuant to



- Gas Appliances Directive (2009/142/EC) in conjunction with EN 161 and EN 13611
- Low Voltage Directive (2006/95/EC),
- EMC Directive (2004/108/EC).

AGA approved



Australian Gas Association, Approval No.: 2725

http://www.aga.asn.au/product_directory

Eurasian Customs Union



The product VAN meets the technical specifications of the Eurasian Customs Union.

3 Function

3.1 Magnetic relief valve VAN

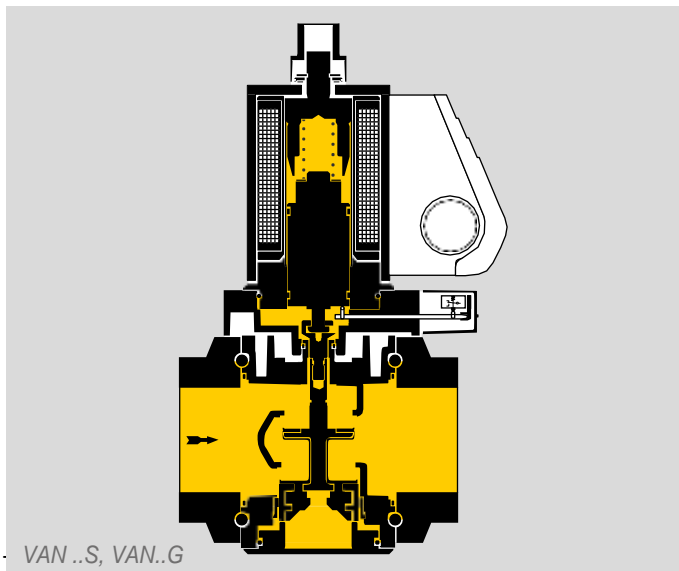

energized.

Closing: connect the system to the electrical power supply (alternating voltage will be rectified). The blue LED lights up. The coil's magnetic field pulls the armature with the attached valve discs upwards. The magnetic relief valve VAN closes. The double valve seat means that the forces from the inlet pressure are divided almost equally between the two valve seats.

Opening: disconnect the VAN from the electrical power supply. The blue LED goes out. The armature is pressed into its initial position by the closing spring. The magnetic relief valve opens within 1 s.

3.2 Magnetic relief valve VAN ..S, VAN ..G

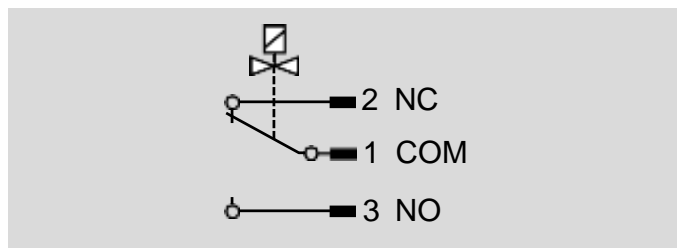

The magnetic relief valve VAN..S, VAN..G is open when it is de-energized.

Closing: when the magnetic relief valve is closed, the closed position switch is operated. The visual position indicator is activated. The "closed" signal is marked in red. The double valve seat closes to shut off the volume of gas.

Opening: the magnetic relief valve is disconnected from the voltage supply and the opening spring forces the double valve disc open. The closed position switch switches. The visual position indicator is white for "open".

The actuator cannot be rotated on magnetic relief valves VAN..S, VAN..G with closed position switch and visual position indicator.

3.3 Animation

The interactive animation shows the function of the magnetic relief valve VAN.

Click on the picture. The animation can be controlled using the control bar at the bottom of the window (as on a DVD player).

To play the animation, you will need Adobe Reader 7 or a newer version. If you do not have Adobe Reader on your system, you can download it from the Internet.

If the animation does not start to play, you can download it from the document library (DOCUTHEK) as an independent application.

3.4 Connection diagram

Wiring to EN 60204-1.

3.4.1 VAN with M20 cable gland

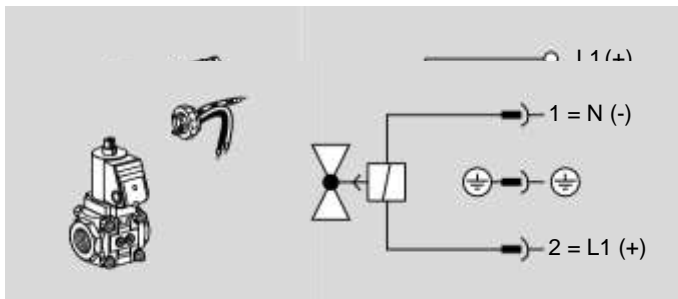

3.4.2 VAN with plug

3.4.3 VAN .S, VAN .G with closed position switch and visual position indicator

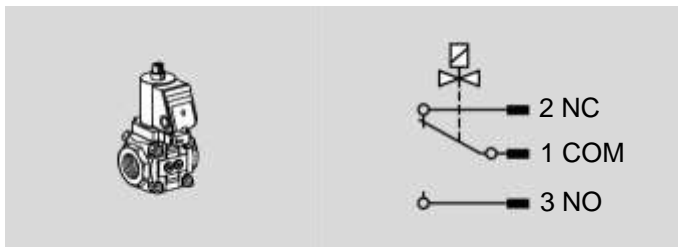

4 Replacement possibilities

Type			Type
VAN	Magnetic relief valve		Magnetic relief valve
15	DN 15		Size 1 DN 15
20	DN 20		Size 1 DN 20
25	DN 25		Size 1 DN 25
40/32	DN 40	32 mm (1.26") internally	Size 2 DN 32
T	T-product		T-product
R	Rp internal thread		Rp internal thread
N	NPT internal thread		NPT internal thread
02	p _u max.: 200 mbar (2 psig)		p _u max.: 500 mbar (7 psig)
10	1000 mbar (14.5 psig)		-
N	Quick opening		Quick opening
K	Mains voltage: 24 V DC		Mains voltage: 24 V DC
Q	120 V AC		120 V AC
W	230 V AC		230 V AC
3	Terminal connection box, IP 54		Terminal connection box, IP 65
6	Terminal box with 3-pin standard socket, IP 54		Terminal box with 3-pin standard socket, IP 65
6L	Terminal box with 3-pin standard socket, with lamp, IP 54		-
1	Screw plug at the inlet		Screw plug at the inlet
CPS	Closed position switch		CPS with visual position indicator CPS for 24 V with visual position indicator

VAN 20R02NW3CPS

= standard, = available

Example

Example

VAN 120RNW3S

4.1 Search for order number or type

van 15

Previous Order No. Previous type designation

85227060	VAN 15R02NK31
85227071	VAN 15R02NK31CPS
85227061	VAN 15R02NK61
85227073	VAN 15R02NK61CPS

Hits:
39

VAN 15 – 40/32 is to be replaced by VAN 110 – 250

New Order No. 88012142

New type designation VAN 115R/NK

6 Selection

6.1 Selection table

Type	T ¹⁾	10	15	20	25	32	40	50	R	N ¹⁾	/N	K	P	Q	Y	W	S	G	R	L	3				
VAN 1	○	●	●	●	●				●	○	●	●	●	●	●	●	○	○	○	○	○	●	○ ²⁾	○ ³⁾	
VAN 2	○			●	●	●	●		●	○	●	●	●	●	●	●	○	○	○	○	○	○	●	○ ²⁾	○ ³⁾

○ = standard, ● = available

1) VAN..T is delivered with NPT thread.

2) Plug with socket.

3) Plug without socket.

Order example

VAN 125R/NWS3

6.1.1 Type code

Code	Description	
VAN	Magnetic relief valve	
1	Size: 1	
2	2	
T	T-product	
10	Nominal diameter [DN]: 10	
15		15
20		20
25		25
32		32
40		40
50	50	
R	Rp internal thread	
N	NPT internal thread	
/N	Quick opening, quick closing	
K	Mains voltage: 24 V DC	
P		100 V AC, 50/60 Hz
Q		120 V AC, 50/60 Hz
Y		200 V AC, 50/60 Hz
W		230 V AC, 50/60 Hz
S	Closed position switch: with visual position indicator	
G		with visual position indicator and gold contacts
R	Viewing side: right	
L		left
3	Electrical connection: M20 cable gland	

7 Project planning information

7.1 Installation

Do not store or install the unit in the open air.

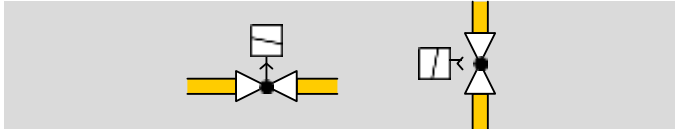

Installation position: black solenoid actuator in the vertical upright position or tilted up to the horizontal, not upside down.



The magnetic relief valve VAN must not be in contact with masonry. Minimum clearance 20 mm (0.79 inches).

Ensure that there is sufficient space for installation and adjustment.



The solenoid actuator heats up during operation. Surface temperature approx. 85°C (approx. 185°F) pursuant to EN 60730-1.

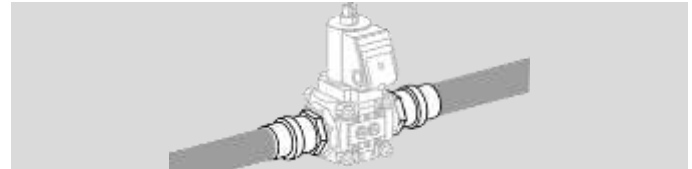

The seals in some gas compression fittings are approved for temperatures of up to 70°C (158°F). This temperature limit will not be exceeded if the ambient temperature is no more than 40°C (104°F).

7.1.1 Relief line for the NAFTA market

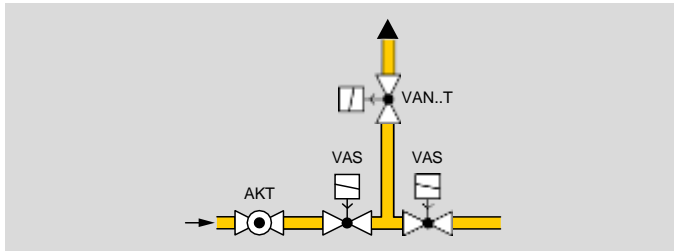

A valve, open when de-energized, is compulsory for capacities over 117 kW (400,000 BTU/h) for purging gas to a safe area.

The downstream relief lines on the VAN may not be interconnected. They must be designed in accordance with the IRI requirements for gas burners.

IRI requirements for gas burners

Pipe size for gas supply		Relief line size	
NPT	DN	NPT	DN
< 1½"	< 40	¾"	20
2"	50	1"	25
2½"	65	1¼"	32
3½"	80	1½"	40
4"	100	2"	50
5"	125	2½"	65

8 Accessories

8.1 Exhaust ABG

Potential explosive areas may be created at the discharge points of relief lines. The exhaust ABG enables the vertical, upwards exhaustion of the gases over the roof edges into the atmosphere. The exhaust ABG may be connected to safety relief valves or manifold lines. It is suitable for pressures on the exhaust outlet of up to 1.5 bar (21.75 psig). The exhaust's outlet openings are fitted with anti-bird grilles.

It is the responsibility of the operator to determine the explosion-hazard areas and to specify and document these zones. Instructions for this can be found in the DVGW note G442, the rules and regulations issued by employers liability insurance associations the German Technical Rules for Industrial Safety and Health (TRBS), as well as further relevant publications.

8.1.1 Installation instructions

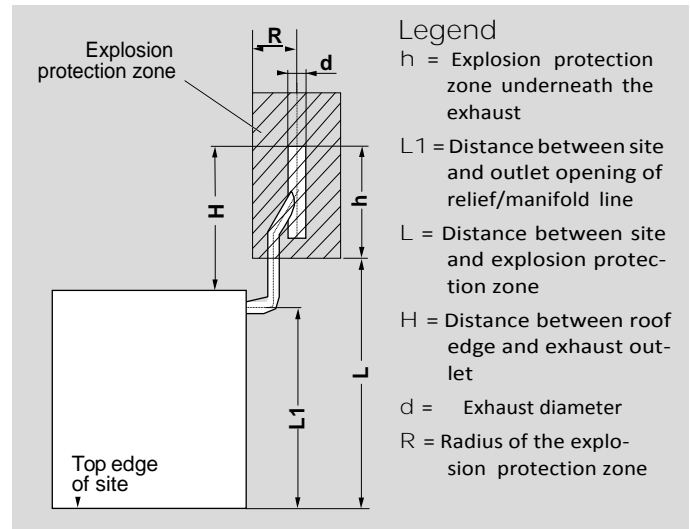

Install the exhaust ABG so as to guarantee the free flow and jet spreading of the outflowing gas. The exhaust should clearly project out over the roof edge ($H = 15 \times d$). The outlet openings of the relief or manifold lines should lie ≥ 1.8 m (6 ft) over the top edge of the site (L1). The connection pipe for the exhaust ABG can be shortened, where applicable. Here it should be noted that the explosion protection zone underneath the exhaust remains big enough ($h = 10 \times d$) and the distance between the explosion protection zone and the site is ≥ 2 m (6.6 ft) (L).

8.1.2 Selection

Type	/40	/80
ABG 25		-
ABG 50	-	

Order example

ABG 25/40

Type code

Code	Description
ABG	Exhaust for gas pressure control and measuring systems
25	Connection pipe nominal diameter [DN]:
50	
/40	Exhaust nominal diameter [DN]:
/80	

Exhaust ABG 25/40, Order No. 03165011,

Exhaust ABG 50/80, Order No. 03165013.

8.1.3 Technical data

Version: steel welded, hot-galvanized.

Connection pipe length: 1100 mm (43.3 inches).

Dimensions

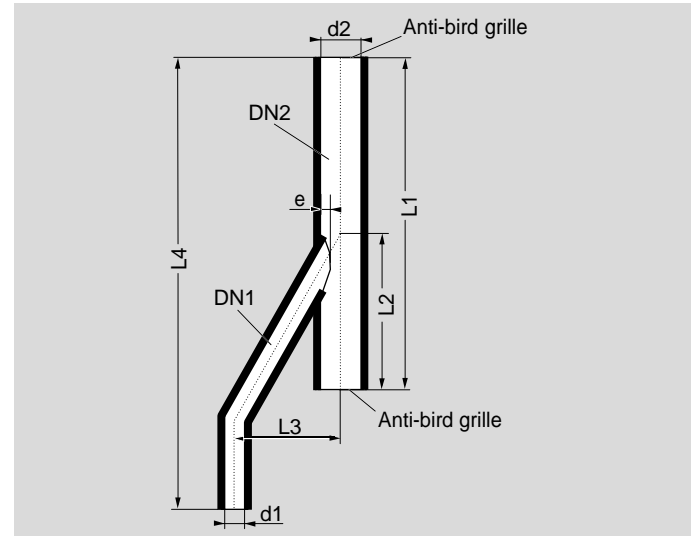

Type	Nominal diameter [DN]		Dimensions [mm] (inch)					Dimensions [mm] (inch)			
	DN1	DN2	L1	L2	L3	L4	e	DN1		DN2	
								d1	Wall thickness	d2	Wall thickness
ABG 25/40	25	40	350 (13.8)	160 (6.3)	130 (5.12)	1100 (43.3)	4.0 (0.16)	33.7 (1.33)	2.6 (0.1)	48.3 (1.9)	2.6 (0.1)
ABG 50/80	50	80	560 (22.05)	250 (9.84)	200 (7.87)	1100 (43.3)	8.0 (0.31)	60.3 (2.37)	2.9 (0.11)	88.9 (3.5)	3.2 (0.13)

8.2 Relief line adapter

For the connection of a relief line (1½ NPT, Rp 1), with a screw plug or pressure test point.

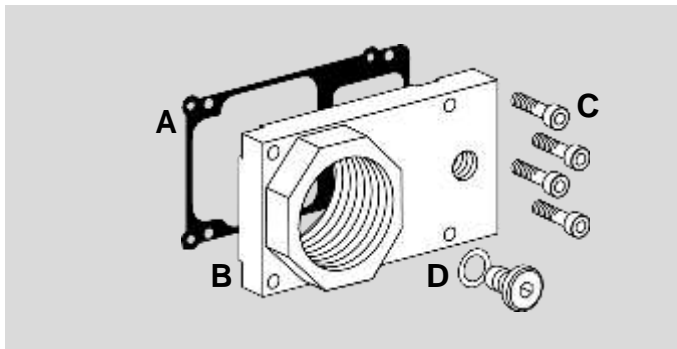

Rp 1, VAS/VCS 6 – 9, Order No. 74923025,
 1½ NPT, VAS..T/VCS..T 6 – 9, Order No. 74923024.

Scope of delivery:

- A 1 x seal,
- B 1 x Z flange,
- C 4 x M5 set screws,
- D 1 x screw plug with sealing ring.

8.3 Intermediate elements for VCS 1 →

For the easy installation of the magnetic relief valve onto a double solenoid valve VCS 1 to 3 using a pipeline with an Rp or an NPT thread.

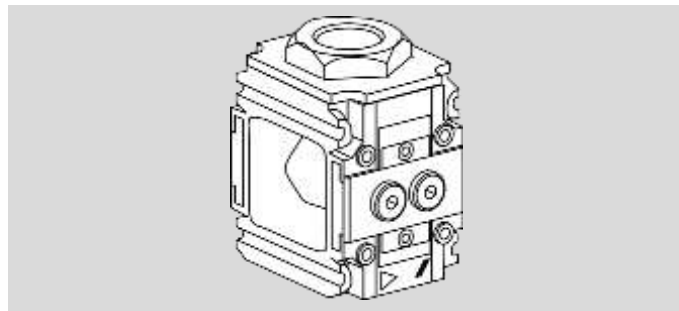

Type	Order No.
Intermediate element VA1 Rp 1/2" /B	74922374
Intermediate element VA2 Rp 3/4" /B	74922413
Intermediate element VA3 Rp 1" /B	74922414
Intermediate element VA1T 1/2" /B	74922655
Intermediate element VA2T 3/4" /B	74922656
Intermediate element VA3T 1" /B	74922657

8.4 Seal set VA 1 →

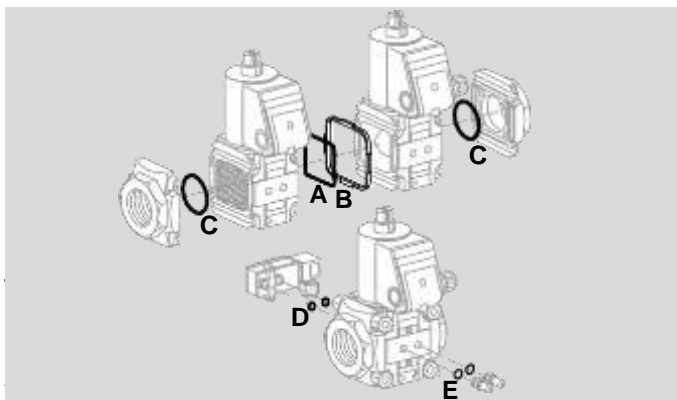

VAN),

- B 1 x retaining frame (the retaining frame is not required for VAN),
- C 2 x O-rings (flange),
- D 2 x O-rings (pressure switch),
for pressure test point/screw plug:
- E 2 x sealing rings (flat sealing) and
2 x profiled sealing rings.

8.5 Pressure switch for gas

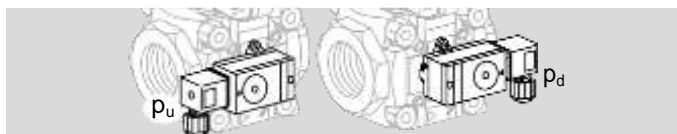

With gold-plated contacts, available for voltages of 5 to 250 V.
 Monitoring the inlet pressure p_u : the electrical plug of the pressure switch for gas points towards the inlet flange.

Monitoring the outlet pressure p_d : the electrical plug of the pressure switch for gas points towards the outlet flange.

Scope of delivery:

- 1 x gas pressure switch,
- 2 x retaining screws,
- 2 x sealing rings.

8.5.1 DG .VC for VAN 1/VAN 2

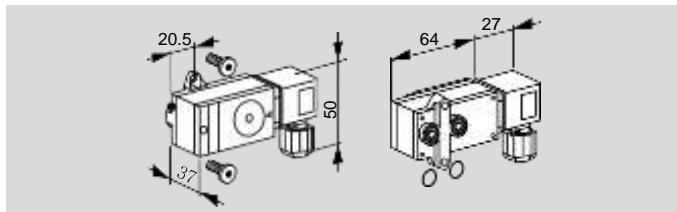

Type	Adjusting range [mbar]
DG 17VC	2 to 17
DG 40VC	5 to 40
DG 110VC	30 to 110
DG 300VC	100 to 300

8.5.2 DG .VCT for VAN 1..T/VAN 2..T
 with AWG 18 connection conductors

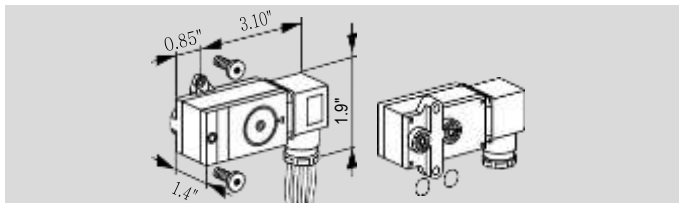

Type	Adjusting range [°WC]
DG 17VCT	0.8 to 6.8
DG 40VCT	2 to 16
DG 110VCT	12 to 44
DG 300VCT	40 to 120

8.5.3 DG .C fastening set for VAX 1 →

Scope of delivery:

2 x retaining screws,

2 x sealing rings.

Order No.: 74921507.

9 Technical data

Gas types: natural gas, LPG (gaseous), biogas (max. 0.1 %-by-vol. H₂S) or air; other gases on request.

The gas must be dry in all temperature conditions and must not contain condensate.

Max. inlet pressure p_u: 500 mbar (7 psig).

Leakage rate: ≤ 500 cm³/h (0.132 gal/h).

Closing time: quick closing: < 1 s.

Ambient temperature: -20 to +50°C (-4 to +122°F), for short periods up to +60°C (+140°F), storage temperature: 0 – 60°C (32 – 140°F), no condensation permitted.

Long-term use in the upper ambient temperature range accelerates the ageing of the elastomer materials and reduces the service life (please contact manufacturer).

Safety valve:

Class A, Group 2 pursuant to EN 13611 and EN 161.

Mains voltage:

230 V AC, +10/-15%, 50/60 Hz;

200 V AC, +10/-15%, 50/60 Hz;

120 V AC, +10/-15%, 50/60 Hz;

100 V AC, +10/-15%, 50/60 Hz;

24 V DC, ±20%.

Cable gland: M20 x 1.5.

Electrical connection: cable with max. 2.5 mm² (AWG 12) or plug with socket to EN 175301-803.

Power consumption:

Type	24 V DC [W]	100 V AC [W]	120 V AC [W]	200 V AC [W]	230 V AC [W]
VAN 1	25	25 (26 VA)	25 (26 VA)	25 (26 VA)	25 (26 VA)
VAN 2	36	36 (40 VA)	40 (44 VA)	40 (44 VA)	40 (44 VA)

Enclosure: IP 65.

Duty cycle: 100%.

Power factor of the solenoid coil: cos φ = 1.

Switching frequency: any.

Valve housing: aluminium.

Valve seal: NBR.

Connection flanges with internal thread: Rp to ISO 7-1, NPT to ANSI/ASME.

Closed position switch contact rating:

Type	Voltage	Min. current (resistive load)	Max. current (resistive load)
VAN..S	100 – 250 V AC, 50/60 Hz	100 mA	3 A
VAN..G	12 – 30 V DC	2 mA	0.1 A

Switching frequency: 5 x per minute.

Switching current [A]	Switching cycles*	
	cos φ = 1	cos φ = 0.6
0.1	500,000	500,000
0.5	300,000	250,000
1	200,000	100,000
3	100,000	–

* Limited to max. 200,000 cycles for heating systems

9.1 Dimensions

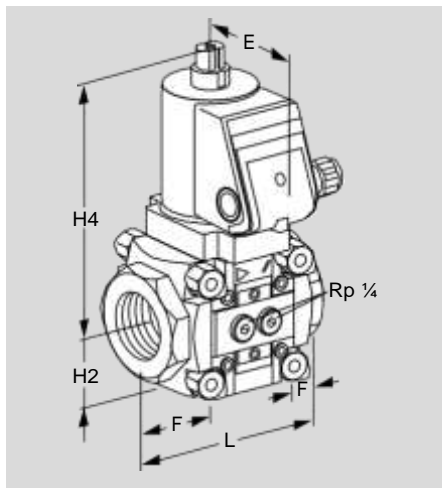

9.1.1 VAN with Rp internal thread [mm]

Type	Connection		Dimensions					Q air with	k _v max.	Weight
	Rp	DN	L	E	F	H2	H4	Δp = 1 mbar		
			mm	mm	mm	mm	mm	m ³ /h	m ³ /h	kg
VAN 110	3/8	10	75	75	15	34	161	4.4	5.0	1.4
VAN 115	1/2	15	75	75	15	34	161	5.5	6.4	1.4
VAN 120	3/4	20	91	75	23	34	161	8.3	9.6	1.5
VAN 125	1	25	91	75	23	34	161	10.0	10.9	1.4
VAN 225	1	25	128	88	29	52	183	15.5	19.2	3.8
VAN 232	1 1/4	32	128	88	29	52	183	19.5	24.1	3.8
VAN 240	1 1/2	40	128	88	29	52	183	21.0	26.9	3.8
VAN 250	2	50	128	88	29	52	183	22.5	26.9	3.6

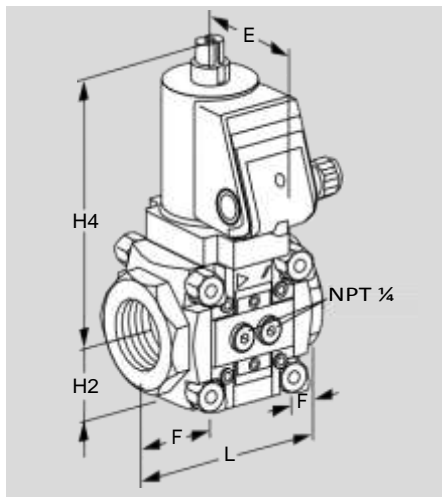

9.1.2 VAN with NPT internal thread [inch]

Type	Connection		Dimensions					Q air with	c _v max.	Weight
	NPT	DN	L	E	F	H2	H4	Δp = 0.4 "WC		
			inch	inch	inch	inch	inch	SCFH	gal/min.	lbs
VAN 110	3/8	10	2.95	2.95	0.59	1.34	6.34	155.36	5.81	3.08
VAN 115	1/2	15	2.95	2.95	0.59	1.34	6.34	194.23	7.44	3.08
VAN 120	3/4	20	3.58	2.95	0.91	1.34	6.34	300.17	11.16	3.30
VAN 125	1	25	3.58	2.95	0.91	1.34	6.34	374.34	12.67	3.08
VAN 225	1	25	5.04	3.32	1.14	2.05	7.20	618.01	22.32	8.36
VAN 232	1 1/4	32	5.04	3.32	1.14	2.05	7.20	759.27	28.02	8.36
VAN 240	1 1/2	40	5.04	3.32	1.14	2.05	7.20	829.89	31.27	8.36
VAN 250	2	50	5.04	3.32	1.14	2.05	7.20	868.74	31.27	7.92

บริษัท: บริษัท เอดีดี เฟอร์เนส จำกัด
Add Furnace Co.,Ltd.

ที่อยู่:(bangkok) 44 ซ.บรมราชชนนี 70 ถ.บรมราชชนนี ศาลาธรรมสพน์ ทวีวัฒนา กทม. 10170.

website: <https://www.add-furnace.com/>

e-mail: sales@add-furnace.com add028883472@gmail.com

โทร.(ออกแบบ): 08-08-170-170, 088-300-1122

โทร: 02-888-3472

Online Support: Line ID: @add11 Wechat ID: add0883001122

แฟกซ์: 02-888-3258



line ID:

@add11

The current addresses of our international agents
are available on the Internet:
www.kromschroeder.de/Weltweit.20.0.html?&L=1

We reserve the right to make technical
modifications in the interests of progress.
Copyright © 2017 Elster GmbH
All rights reserved.