



บริษัท เอดีดี เฟอร์เนส จำกัด

ADD FURNACE CO.,LTD.

44 ซอยบรมราชชนนี 70 ถนนบรมราชชนนี แขวงศาลาธรรมสพน์ เขตทวีวัฒนา กรุงเทพฯ 10170

โทร: 02-888-3472 โทร: ออกแบบ:08-08-170-170 แฟกซ์: 02-888-3258

<https://www.add-furnace.com> E-mail: [sales@add-furnace.com](mailto:sales@add-furnace.com)

# SHIMADEN SERVO CONTROLLER

Shimaden, Temperature and Humidity Control Specialists

## series EM51

- Small Size 80 (H) × 50 (W) mm
- Easy Installation
- Plug-in Type



### SPECIFICATIONS

Input:	See ordering information.
Feedback Resistance:	100Ω~2kΩ random / 3-wire
Output:	Relay contact or Triac (SSR)
Output Rating / Contact Protection:	Relay contact = 240V AC, 1A (inductive load) / CR Absorber Triac (SSR) = 20~120V AC / (inductive load) / CR Absorber + varistor
Sensitivity:	Approx. 0.5% fixed of input signal range
Dead Band:	1~10% variable of input signal range
Output Operation Display:	M2-M1 / LED green lighting M2-M3 / LED red lighting
Operating Ambient Temperature Range:	-10~+50 °C
Operating Ambient Humidity:	90% RH max.
Power Supply:	See ordering information.
Power Consumption:	Approx. 3V A
Insulation Resistance:	500V DC, 100MΩ between the input and power supply terminals 500V DC, 100MΩ between the output and power supply terminals
Dielectric Strength:	1 min. at 1000V AC between the output and power supply terminals
External Dimensions:	80 (H) × 50 (W) × 130 (D) mm
Installation:	11P plug-in
Weight:	Approx. 350g



**ORDERING INFORMATION**

ITEM	CODE	SPECIFICATIONS
SERIES	EM51-	Plug-In Type Servo Controller
CONTROL INPUT	1	1~5mA DC, Receiving resistance: 250Ω
	2	4~20mA DC, Receiving resistance: 62Ω
	3	0~10V DC, Input resistance: 200kΩ
	9	Others (Please consult before ordering.)
OUTPUT	Y	Contact 240V AC, 1A (inductive load)
	S	Triac 20~120V AC, 1A (inductive load) (Motor Supply Voltage: 20~120V AC)
POWER SUPPLY	13-	100~110V AC ± 10%, 50 / 60Hz
	14-	110~120V AC ± 10%, 50 / 60Hz
	15-	200~220V AC ± 10%, 50 / 60Hz
	16-	220~240V AC ± 10%, 50 / 60Hz
	99-	Others (Please consult before ordering.)
REMARKS	0	Without
	9	With (Please consult before ordering.)

**CONNECTION DIAGRAM**

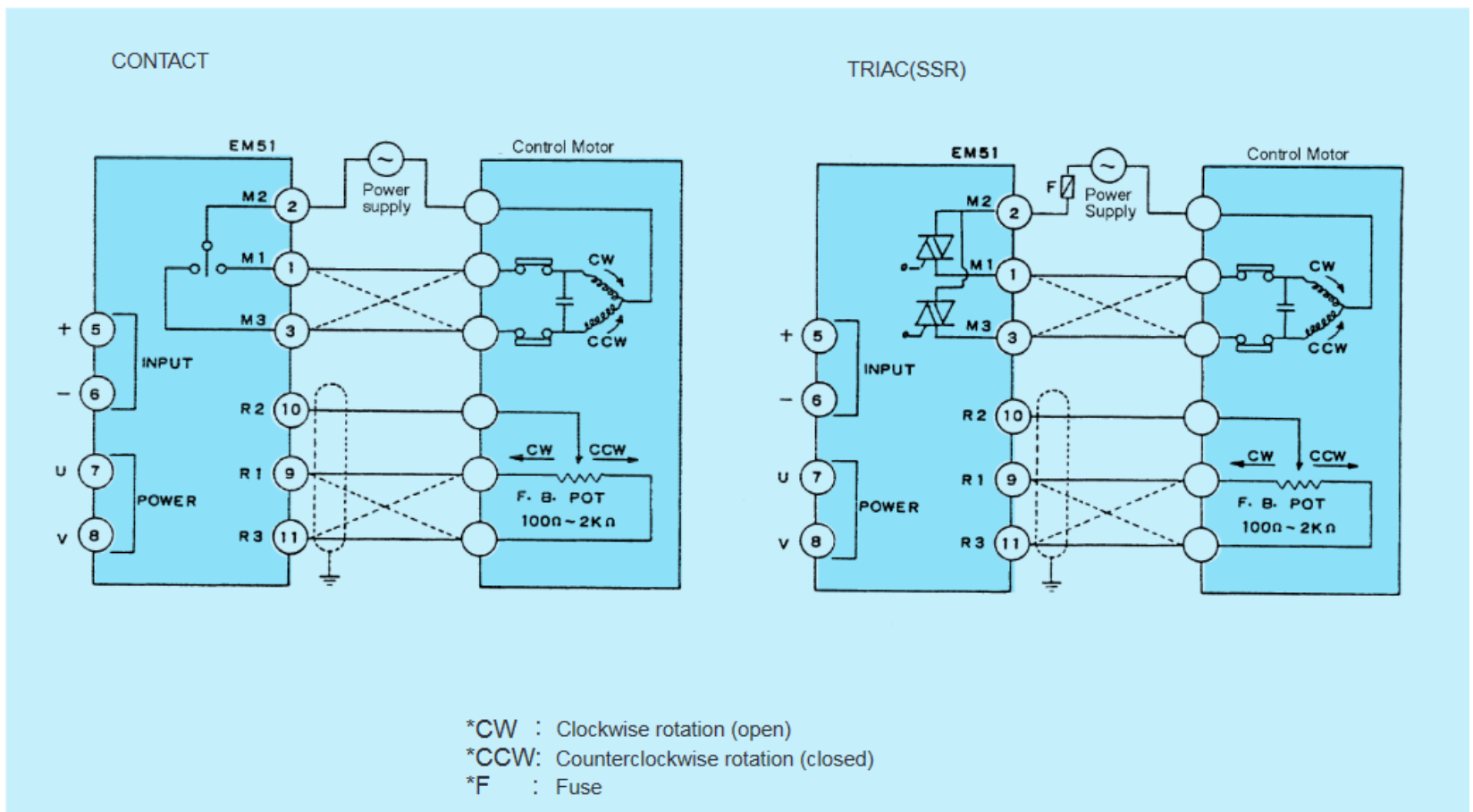

\* When reversing the motor rotation, convert the terminal connections M1-M3 and R1-R3 as per the dotted lines

\* For model with Triac (SSR), motor power supply voltage range must be 20~120V AC.

\* Recommend to use fuse between terminal M2 and power supply terminals to protect motor when malfunctioned.

**RELAY ACTIONS**

Characteristic	Run	Increased	Balanced	Decreased
RA	Heat	M2-M1: ON (Open)	M2-M1, M3: OFF (Stop)	M2-M3: ON (Close)
DA	Cool	LED Green lights.		LED Red lights.



บริษัท เอดีดี เฟอร์เนส จำกัด

ADD FURNACE CO.,LTD.

44 ซอยบรมราชชนนี 70 ถนนบรมราชชนนี แขวงศาลาธรรมสพน์ เขตทวีวัฒนา กรุงเทพฯ 10170

โทร: 02-888-3472 โทร: ออกแบบ:08-08-170-170 แฟกซ์: 02-888-3258

https://www.add-furnace.com E-mail: [sales@add-furnace.com](mailto:sales@add-furnace.com)

# SHIMADEN SERVO CONTROLLER

## INSTALLATIONS

- \* Free from corrosive gasses.
- \* Away from direct sunlight, impact and radiant heat from electric ovens or other heat equipment

## ADJUSTMENT

### 1. Characteristics of Input Signal vs. Operating Output

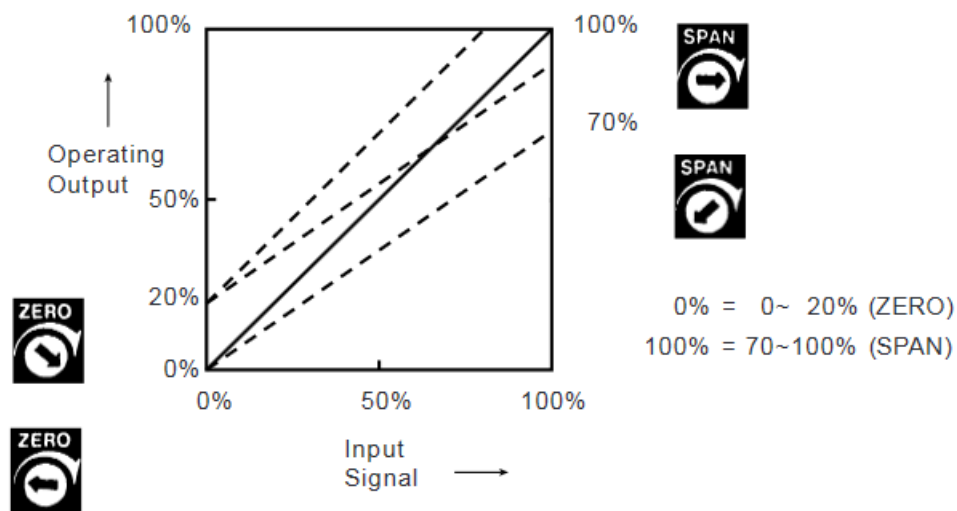

### 2. Adjustment of Operating Output

Confirm that the final control element is at 100% or the open position when 100% input signal is applied, and at 0% or the closed position when 0% input signal is applied.

If there is any dislocation at the 100% and / or 0% position, adjust the ZERO and SPAN trimmers accordingly.

Note: Since the reaction of the final control element is normally slow, adjust the ZERO and SPAN trimmers slowly.

### 3. Adjustment of Deadband

The dead band means the sensitivity between the clockwise (open) and counterclockwise (close) actions of the control motor.

If the control motor repeats quick hunting, turn the dead band from the narrow band gradually to the wide band until hunting stops.

If the dead band is set unnecessarily wide, the control motor may be dull in response

## EXTERNAL DIMENSIONS AND PANEL CUTOUT

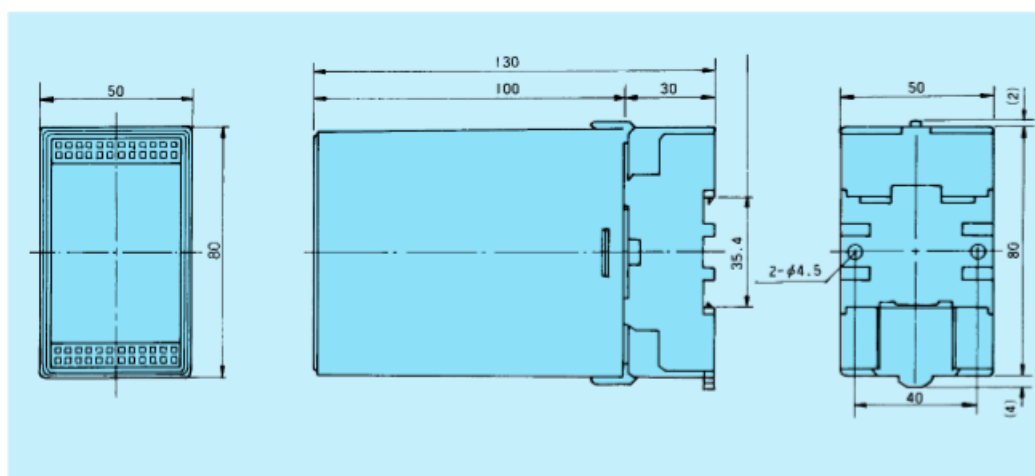

## TERMINAL ARRANGEMENT

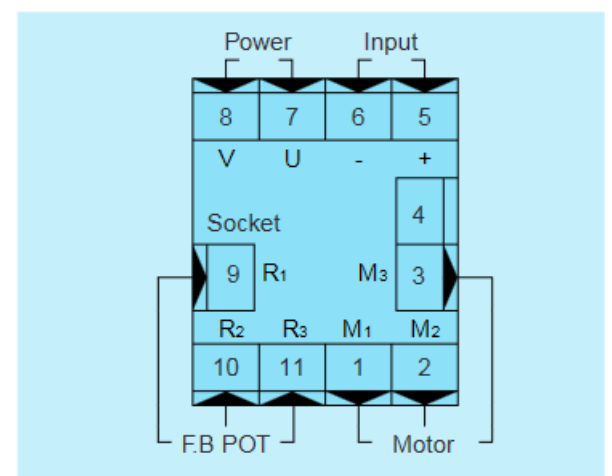



บริษัท เอดีดี เฟอร์เนส จำกัด

**ADD FURNACE CO.,LTD.**

44 ซอยบรมราชชนนี 70 ถนนบรมราชชนนี แขวงศาลาธรรมสพน์ เขตทวีวัฒนา กรุงเทพฯ 10170

โทร: 02-888-3472 โทร: ออกแบบ:08-08-170-170 แฟกซ์: 02-888-3258

<https://www.add-furnace.com> E-mail: [sales@add-furnace.com](mailto:sales@add-furnace.com)

**SERIES EM51**

 **Warning**

- This product is designed for the control of temperature, humidity and other physical values for the general industrial equipment. It is not to be used for any purpose which regulates the prevention of serious effects on human life or safety. No warranty, express or implied is valid if used without proper safety measures.

 **Caution**

- If the possibility of loss or damage to your system or property as a result of failure of any part of the process exists, proper safety measures must be made before the instrument is put into use as to prevent the occurrence of trouble.