



บริษัท เอดีดี เฟอร์เนส จำกัด

ADD FURNACE CO.,LTD.

44 ซอยบรมราชชนนี 70 ถนนบรมราชชนนี แขวงศาลาธรรมสพน์ เขตทวีวัฒนา กรุงเทพฯ 10170

โทร: 02-888-3472 โทร: ออกแบบ:08-08-170-170 แฟกซ์: 02-888-3258

<https://www.add-furnace.com> E-mail: sales@add-furnace.com

SRP30 Series

Hybrid Controller

Instruction Manual

(Detailed Version)

Thank you for making a purchase of our product. After making sure that this is the product you have requested, please read carefully the Instruction Manual (Detailed Version) to ensure that you understand it sufficiently and use the product correctly.

SHIMADEN CO., LTD.

MSRP30-E01-C

Jun. 2022



Note

Please make sure that this Instruction Manual (Detailed Version) is received by the final user of the product. When operating SRP30 Series Hybrid Controller, make sure that this Instruction Manual (Detailed Version) is always on hand.

Foreword

This Instruction Manual (Detailed Version) explains the basic functions and usage directions of SRP30 Series Hybrid Controller.

Furthermore, this manual also explains handling caution points, installation and wiring procedures for personnel engaged in the various work activities involving the SRP30 Series Hybrid Controller including wiring, installation, operation and daily maintenance.

Please make sure that you follow the content of this Instruction Manual (Detailed Version n), as well as the safety reminders and caution points below pertaining to the breakage of apparatus and equipment, and additional explanatory notes and provisos.

Safety Reminders



Warning

SRP30 Series Hybrid Controller is control equipment designed and manufactured for industrial use to control temperature, moisture and other physical quantities.

For this reason, please avoid using this for control operations that may have major adverse effects on human life.

Likewise, the client should take responsibility to put in place safety measures in using this product.

Our company is not responsible for accidents that arise because of the client's failure to take adequate safety measures.



Warning

- In placing this instrument into the control board, please make sure that work proceeds without the installer touching the terminal.
- Please make sure not to open the case of this instrument, touch the circuit board, or place your hand or any conductive material inside the case.

Likewise, do not try to repair or alter this equipment by yourself. There is danger of sustaining major injuries from electrocution.



Caution

To prevent breakage of and/or damage to peripheral devices, equipment and products as a result of breakdown of this instrument, please use this only after fuse installation, activation of overheating prevention device, and other safety measures. Our company is not responsible for accidents that arise because of the customer's failure to take adequate safety measures.

- The warning mark on the nameplate attached to the case of this instrument is “to strongly remind one not to touch the charging part while it is live because of the risk of electrocution.”
- As a means to cut the power supply, please install a switch or breaker to the external power supply circuit connected to the power supply terminal of this instrument .
Please fix the position of the switch or breaker close to this instrument and within easy reach of the operator, and indicate that it is the power breaker of this instrument .
- There is no built-in fuse in this instrument, so please fit “a 250 V 1.0A/ medium time-lagged type or time-lagged type” fuse in the power supply circuit attached to the power supply terminal.
- In wiring, make sure to tighten the terminal connection part.
- Please use power voltage and frequency within the rated value.
- Please do not add voltage or current other than the input standard to the input terminal.
This may shorten the product life span or cause breakage of the instrument.
- In connecting a load to the output terminal, please use voltage and current within the rated value.
If you exceed this, the rise in temperature may shorten the product life span or cause breakage of the instrument .
- A heat ventilation hole was created in this instrument.
Take caution not to put metallic foreign objects inside because that can cause breakage of the instrument.
Also, make sure not to shut the ventilation hole nor allow dust to adhere to it.
The rise in temperature and failure of insulation may shorten the product life span and cause breakage of the instrument .
- Refrain from repetition of tolerance test for dielectric strength, anti-noise, and anti-surge because it may lead to the deterioration of this instrument .
- Never alter this instrument by yourself nor make an irregular use of it.
- Please use this instrument safely and correctly. To maintain its reliability, make sure to follow all the important points in the Instruction Manual.
- Please do not use a hard or hard-edged object on the front key of this instrument. Make sure to operate that key lightly with your fingertips.
- In cleaning, do not use a solvent like thinner but wipe lightly using a dry cloth.
- It takes 30 minutes for the correct temperature to be displayed once you add a power supply in this instrument . (You have to connect the power supply earlier than the actual time you begin the control operation.)
- To ensure safety and maintain the functions of this device, do not disassemble this device.
If this device must be disassembled for replacement or repair, contact your dealer.
- This device is designed for mounting on the panel. Only the device mounted on the front of the panel facing outward is of protection class of IP55. Do not use for the device not facing outward or in environment where water or solids in excess of IEC60529 may get inside.



Please Check the Product

This instrument has undergone quality inspection before shipment. Upon receiving it, please check its model code, external appearance and accessories for possible mistake, damage, or missing items.

Checking the Model Code

Please compare the code label attached to the case with that of the ordering information to check if the product you received is what you ordered.

Checking the Accessories

Please check if the following accessories are complete.

■ Standard Accessories

- (1) Instruction Manual (Basic Version)
- (2) Mounting tools (screw, 2 pcs.)
- (3) Terminal cover
- (4) Unit seal

■ Optional Accessories

Termination resistor (when selecting communication option RS-485)

Items Sold Separately Option

We sell the following items separately as options.

Name of Item	Model	Description
Shunt resistor	QCS002	250Ω external receiving impedance during current input
Relay unit	AP2MC	Open collector output is converted into contact output, 2 built-in circuits
CT	QCC01	CT for 30 A
CT	QCC02	CT for 50 A
Micro USB cable	QCUS001	A male connector ⇔ Micro B male connector (2 m)

* We make the following operational check on the converter.

USB/RS-485 Converter: LINEEYE-made SI-35USB

USB/RS-232 Converter: LINEEYE-made SI-55USB



■ Code Selection Table

ITEM	CODE	SPECIFICATIONS	
1. SERIES	SRP33-	96 x 96 DIN size Hybrid controller	TC, RTD, mV, V, mA Full multi input (mA is input by externally attached resistor)
	SRP34-	48 x 96 DIN size Hybrid controller	DI2 point, EV3 point, USB Control standard equipment
2. CONTROL OUTPUT 1	Y	Contact: 1a contact capacity 240 V AC 2.5A/resistive load, 1A/inductive load	
	I	Current: 4–20 mA DC, Load resistance: 600Ω or less	
	P	SSR drive voltage: 12 V±1.5 V DC Load current: 20 mA or less	
	V	Voltage: 0–10 V DC Load current: 2 mA or less	
3. CONTROL OUTPUT 2 (OPTION)	N-	Without	
	Y-	Contact: 1a contact capacity 240 V AC 2.5 A/resistive load, 1 A/inductive load	
	I-	Current: 4–20 mA DC, Load resistance: 600Ω or less	
	P-	SSR drive voltage: 12 V DC±1.5 V DC Load current: 20 mA or less	
	V-	Voltage: 0–10 V DC, Load current: 2 mA or less	
	E-	EV4 Contact, 1a contact capacity, 240 V AC 2.5 A/resistive load, 1 A/inductive load	
4. EXTERNAL CONTROL INPUT (DI) (OPTION)	0	Without	
	1	5 points (DI3–7)	
5. ANALOG OUTPUT (AO) (OPTION)	0	Without	
	3	Voltage: 0–10 mV DC, Output resistance: 10Ω	
	4	Current: 4–20 mA DC, Load resistance: 300Ω or less	
	6	Voltage: 0–10 V DC, Load current: 2 mA or less	
6. EXTERNAL CONTROL OUTPUT (DO) (OPTION)	0	Without	
	1	3 points (DO1–3) Darlington open collector output: 24 V DC 50 mA	
7. ADDITIONAL DO/CT/REM (OPTION)	0	Without	
	1	Additional DO3 points (DO4–6) Darlington open collector output: 24 V DC 50 mA *1	
	2	CT input 2 points, amperage display 0.0–55.0 A *2	
	4	Remote setting input current 4–20 mA DC /receiving impedance 250Ω (non-isolation)	
	5	Remote setting input voltage 1–5 V DC /input resistance approximately 500kΩ (non-isolation)	
	6	Remote setting input voltage 0–10 V DC /input resistance approximately 500kΩ (non-isolation)	
8. CCMMUNICATION (REAR) (OPTION)	0	Without	
	5	RS-485	Shimaden standard protocol
	7	RS-232C	/MODBUS communication protocol
9. REMARKS	0	Without	
	9	With	

*1 Selectable only when adding DO–3

*2 Selectable only when control output 1 or 2 is Y or P



Contents

1	Installation and Wiring.....	23
1-1	Installation site of SRP30 Series.....	23
1-2	External Dimensions and Panel Cutout of SRP30 Series	23
(1)	External Dimensions.....	23
(2)	Panel Cutout.....	24
1-3	Panel Mounting Method for SRP30 Series	24
1-4	External Dimensions Of Current Sensor (CT) for Heater Break Alarm	25
(1)	QCC01 for 0–30A.....	25
(2)	QCC02 for 0–50A.....	25
1-5	SRP30 Series Rear Terminal Arrangement.....	26
1-6	Wiring	27
2	Names and Functions of Front Panel	28
3	Action during Power Application, Screen Transition and Setting Operations..	30
3-1	SRP30 Series Action during Power Application	30
3-2	Screen Display Switching Operation.....	31
(1)	Switching Screen Display	31
3-3	Keylock Setting	32
(1)	Keylock Screen Display.....	32
(2)	Keylock.....	32
3-4	Change and Registration of Various Data	33
(1)	Set Pattern Information.....	33
(2)	Transition to Step Screen Group	33
(3)	Setting Step Information	34
4	Control Output Setting	35
4-1	Control Mode of the SRP30 Series	35
4-2	RESET/RUN Status of Output Action Mode	35
4-3	Manual Control Output (MAN)	36
4-4	Automatic Control Output (AUTO)	36
4-5	Output Limiter.....	36
4-6	Output Change Rate Limiter	36
4-7	Proportional Cycle.....	36
4-8	Power Failure Compensation.....	36



5	Setting SRP30 Series	37
5-1	Parameter Setting Procedure	37
6	Various Monitor Screens Group.....	38
6-1	RESET/RUN Switch	38
6-2	Output Monitor and Manual Output	38
6-3	Execution PID No. Monitor	38
6-4	Monitor of Remaining Time of Step.....	39
6-5	Monitor of No. of Pattern Executions.....	39
6-6	Monitor of No. of Step Loops.....	39
6-7	Pattern Link Monitor	40
(1)	Pattern Link Monitor	40
(2)	Monitor of Repetition No. of Pattern Link	40
6-8	Heater Current Monitor.....	40
6-9	Remote Input Monitor	40
7	Setting EXEC	41
7-1	Automatic/Manual Switching of Control Output.....	41
7-2	Latching Release Setting	41
7-3	Setting Communication Mode	42
7-4	Temporary Hold and Restart of Program	42
7-5	Executing Advance.....	43
7-6	Execution and Termination of Auto-tuning	43
7-7	Pattern Link Related Setting.....	45
(1)	Start Pattern No. Setting	45
(2)	Setting No. of Pattern Link Repetition	45
(3)	Pattern Link.....	46
8	Program Setting	47
8-1	Setting Related to Pattern	47
(1)	End Step	47
(2)	Start Step	47
(3)	Start SV.....	47
(4)	No. of Pattern Executions	48
(5)	Start Step No. of Step Loop	48
(6)	End Step No. of Step Loop	48
(7)	No. of Step Loop Executions.....	48
(8)	Guarantee Soak Zone.....	49
(9)	Guarantee Soak Time	50
8-2	PV Start	51



8-3 Program EV, DO Level (Action Points)	52
8-4 Pattern Information Copy	52
9 Step Setting	53
9-1 Setting Related to Step	53
(1) Step SV Value	53
(2) Step Time	53
(3) Step PID No.	54
9-2 Time Signal	54
(1) Time Signal ON Time	56
(2) Time Signal OFF Time	56
10 Setting FIX	57
10-1 Switching FIX Mode	57
10-2 Setting FIX SV No.....	57
10-3 Setting FIX SV Value.....	58
10-4 FIX EV/DO Action Point	59
11 Setting Remote (REM).....	60
11-1 Remote Bias.....	60
11-2 Remote Filter.....	60
11-3 Remote Ratio	60
11-4 Remote PID.....	61
11-5 Remote Scaling.....	61
11-6 Remote Square Root Extraction	62
11-7 Remote Low Cut	62
11-8 Remote Tracking.....	62
12 Setting PID.....	63
12-1 Proportional Band (P).....	63
12-2 Hysteresis (DF)	63
12-3 Integral Time (I).....	63
12-4 Derivative Time (D)	64
12-5 Manual Reset (MR)	64
12-6 Target Value Function (SF).....	65
12-7 Output Limit Value (OUT1L–OUT2H)	65
12-8 Dead Band (DB).....	66
12-9 Setting Zone PID.....	67
(1) Selection of Zone PID.....	67



(2) PID Zone Value.....	68
(3) Zone Hysteresis	68
13 Setting Event (EV).....	69
13-1 Event Action	69
13-2 Hysteresis	71
13-3 Standby Action	72
13-4 Output Characteristics	72
13-5 Delay Time	73
13-6 Latching Selection	73
14 DO/DI SETTING.....	74
14-1 Setting DO	74
(1) DO Action.....	74
(2) Hysteresis	74
(3) Selection of Standby Action	74
(4) Output Characteristics.....	74
(5) Delay Time.....	75
(6) Latching Selection.....	75
14-2 DI Setting.....	75
(1) DI Assignment Function	75
15 Communication Setting	77
15-1 Outline	77
(1) Communication Interface	77
(2) Communication Control and its Specifications	77
15-2 Connection of Controller and Host Computer	78
(1) When using RS-232C Interface	78
(2) When using RS-485 Interface	79
15-3 Communication.....	80
(1) Communication Control.....	80
(2) Communication Address	80
(3) Communication Data.....	80
(4) Start Character.....	81
(5) Communication BCC Data Operating Method	81
(6) Communication Rate.....	81
(7) Communication Delay Time	82
(8) Communication Memory Mode	82
(9) Communication Mode Types	82
(10) Master Function	83
(11) Communication Slave Start/End Address	83



(12) Time Setting Mode	83
15-4 Shimaden Standard Protocol Explanation	84
(1) Communication Procedure	84
(2) Communication Format	84
(3) Communication Format Outline.....	84
(4) Details of Basic Format Part I	85
(5) Details of Basic Format Part II	85
(6) Text Part Outline	88
(7) Details of Read Command (R)	90
(8) Details of Write Command (W)	92
(9) Details of Broadcast Command (B)	94
(10) Details of Response Code.....	95
15-5 MODBUS Protocol Explanation	96
(1) Transmission Mode Outline.....	96
(2) Message Structure	97
(3) Slave Address	97
(4) Function Code	97
(5) Data.....	98
(6) Error Check	98
(7) Message Example	99
15-6 Communication Data Address List.....	102
(1) Communication Data Address Outline.....	102
 16 Setting Analog Output.....	 121
16-1 Setting Analog Output	121
(1) Selection of Analog Output Type.....	121
(2) Analog Output Scaling.....	121
(3) Analog Output Limiter.....	121
16-2 Analog Output Value when Input is Abnormal	121
 17 Setting Heater Break/Loop Alarm	 122
17-1 Heater Break and Loop Alarm	122
17-2 CT (Current Sensor) Connection	122
17-3 Heater Current Value Monitor	123
17-4 Current Detection Selection	123
17-5 Break Alarm Current Value.....	123
17-6 Loop Alarm Current Value	124
17-7 Heater Break Alarm Output.....	124
17-8 Heater Loop Alarm Output	125
 18 Setting Control Output	 126



18-1	Setting Control Output	126
(1)	Output 1 Output Characteristics	126
(2)	Output 1 Proportional Cycle	126
(3)	Output 1 Change Rate Limiter	126
(4)	Output 1 Output during Error.....	127
(5)	Output 1 Reset Output Value	127
(6)	Setting Output 2	127
19	Setting Unit/Range	128
19-1	Setting PV Correction Value.....	128
(1)	PV Bias	128
(2)	PV Filter	128
(3)	PV Ratio.....	128
19-2	Setting Measuring Range	128
(1)	Setting Range	128
19-3	Setting Unit.....	129
19-4	Input scaling	129
19-5	Display scaling.....	129
19-6	Setting Decimal Point	130
(1)	Position of Decimal Point	130
19-7	Setting Cold Junction Compensation	130
20	Setting Square Root Extraction/10-segment Linear Approximation.....	132
20-1	Setting Square Root Extraction Function	132
(1)	Activation of Square Root Extraction Function.....	132
(2)	Low Cut.....	132
20-2	Setting 10-segment Linear Approximation.....	133
(1)	Activation of 10-Segment Linear Approximation	133
(2)	Setting Contact	133
21	Lock and Other Settings.....	135
21-1	Keylock.....	135
21-2	USB Communication Setting	135
21-3	SV Limiter	135
21-4	Auto-tuning Point.....	136
21-5	Setting Program Time Unit.....	136
21-6	Power Failure Compensation.....	137
21-7	No. of Pattern Used	137
21-8	Two-Position Action.....	138
(1)	Hysteresis Mode	138



21-9	Setting Bar Display.....	139
	(1) Display Mode.....	139
	(2) Scaling.....	139
21-10	Sampling Cycle	140
21-11	Parameter Setting	140
	(1) Parameter Initialization	140
	(2) Reading Parameter	140
	(3) Saving Parameter.....	141
21-12	Liquid Crystal Backlight Brightness.....	141
21-13	Event ON/OFF during Reset.....	141
21-14	Program End Signal Time.....	141
21-15	FIX Switching at Program End	141
22	Run Execution.....	142
22-1	Operation on Basic Screen	142
	(1) Setting Start Pattern	142
	(2) Setting Start Step	142
22-2	Display of Start Step No. and SV No.	142
22-3	Control Execution and Stop Method	143
23	Error Display	144
23-1	Action Check Abnormality when Power is ON.....	144
23-2	PV Input Abnormality	145
23-3	Heater Current Abnormality (Option)	145
24	Parameter List.....	146
24-1	Monitor Setting Screen Group	146
24-2	EXEC Screen Group (Group 1)	147
24-3	Program Screen Group (Group 2)	147
24-4	Step Screen Group (Group 3).....	148
24-5	FIX Screen Group (Group 4).....	148
24-6	Remote (REM) Screen Group (Group 5)	149
24-7	PID Screen Group (Group 6)	149
24-8	Zone PID Screen Group (Group 6)	149
24-9	Event (EV) Setting Screen Group (Group 7)	150
24-10	DO/DI Screen Group (Group 8).....	151
24-11	Communication Setting Screen Group (Group 9).....	152
24-12	Analog Output Setting Screen Group (Group 10).....	152
24-13	Heater Break/Loop Alarm Setting Screen Group (Group 11)	152



24-14	Control Output Screen Group (Group 12)	153
24-15	Unit/Range Setting Screen Group (Group 13)	153
24-16	Square Root Extraction/10-Segment Operation Setting Group (Group 14).....	154
24-17	Lock and other Screen Setting (Group 15)	155

25 Specifications 156

25-1	Display	156
25-2	Setting	157
25-3	Input.....	157
25-5	Control Output 1	159
25-6	Control Output 2 (Option)	159
25-7	Event Output.....	159
25-8	External Control Output (DO) (Option).....	160
25-9	External Control Input (DI).....	160
25-10	Analog Output (AO) (Option).....	161
25-11	Remote setting input (REM) (Option).....	161
25-12	Heater Break Alarm (Option).....	162
25-13	Communication Function (Option)	162
25-14	Front Panel Loader Communication	163
25-15	Program Function.....	163
25-16	General Specifications	164



Sequence Diagram

The displayed screen shift of this instrument is as follows.

Screens with dotted lines are shown or hidden according to the specification, setting, etc.

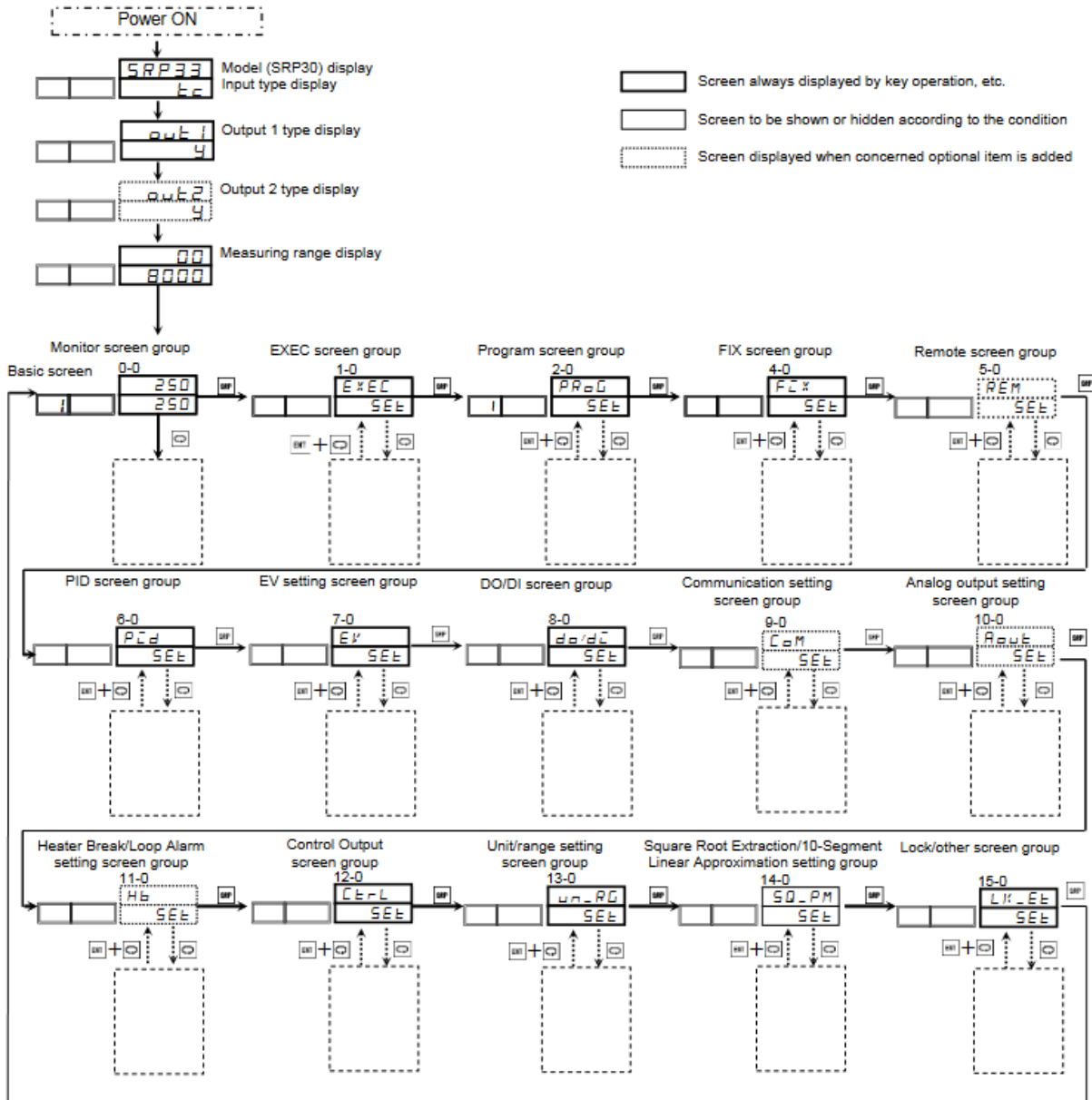

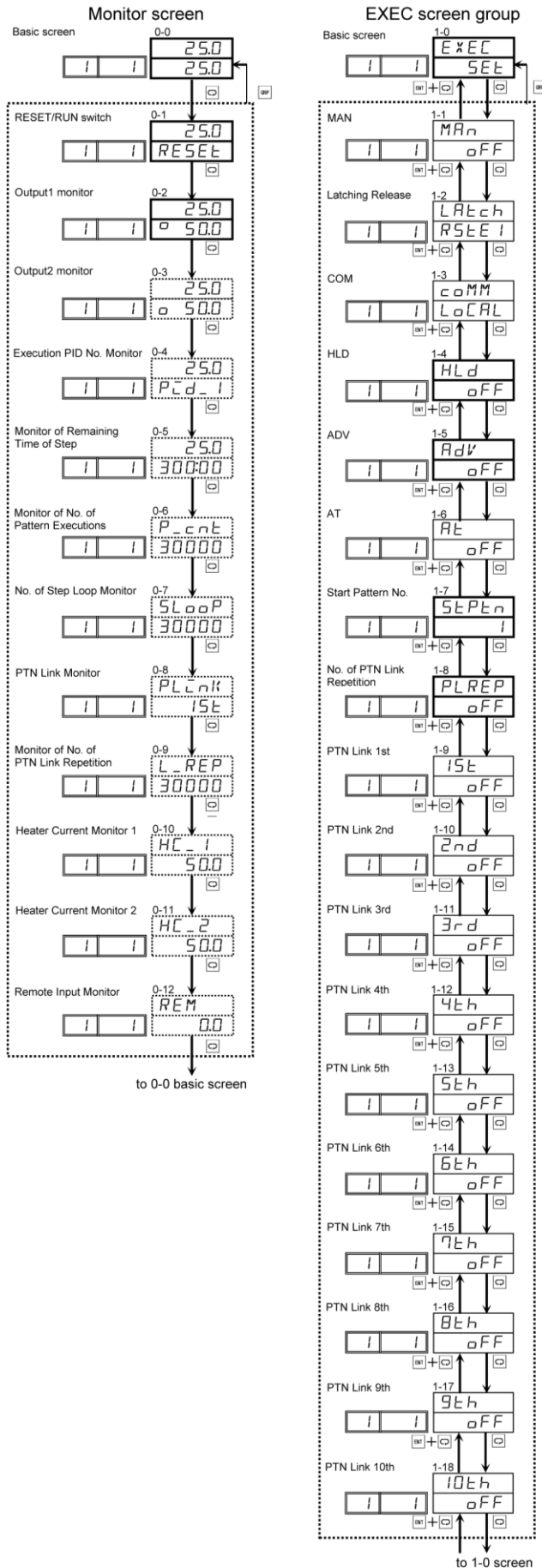

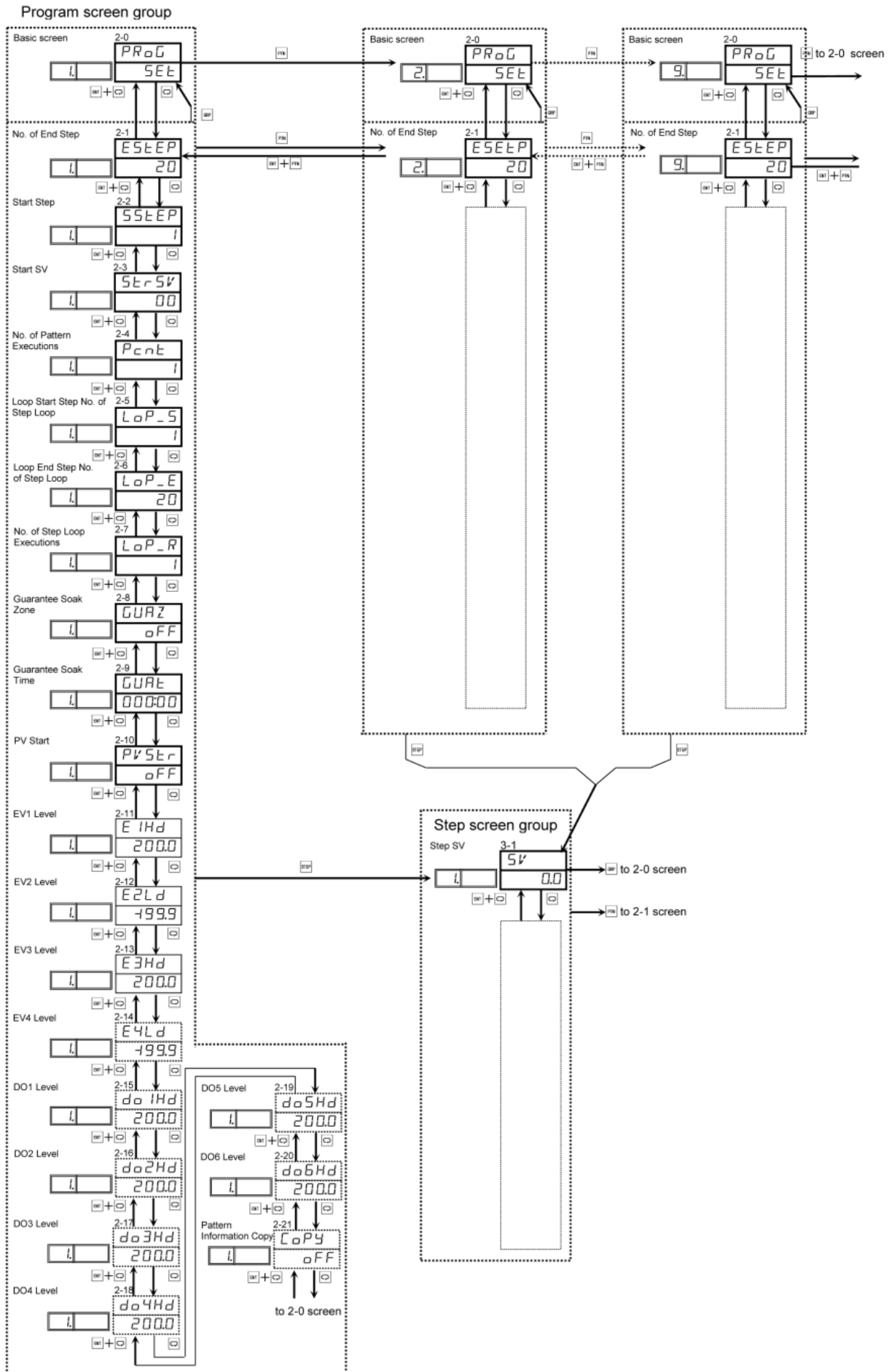

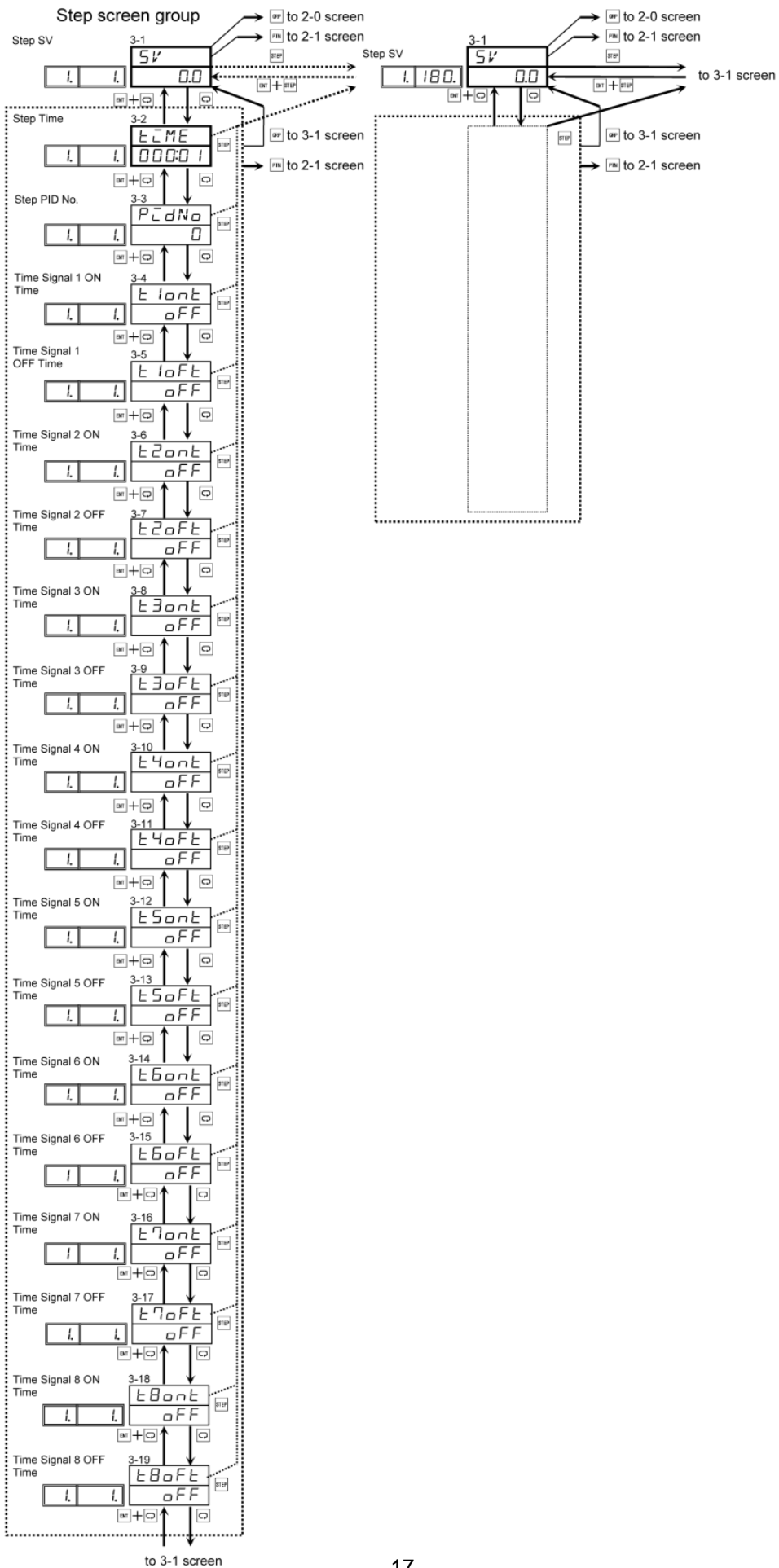



FIX screen group

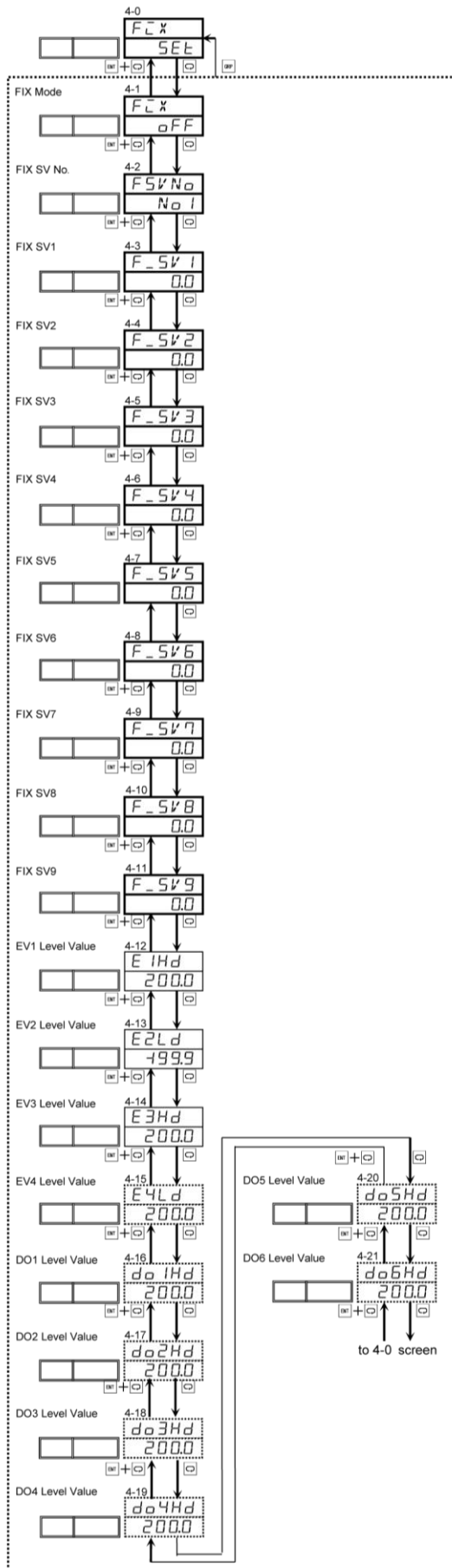

Remote screen group

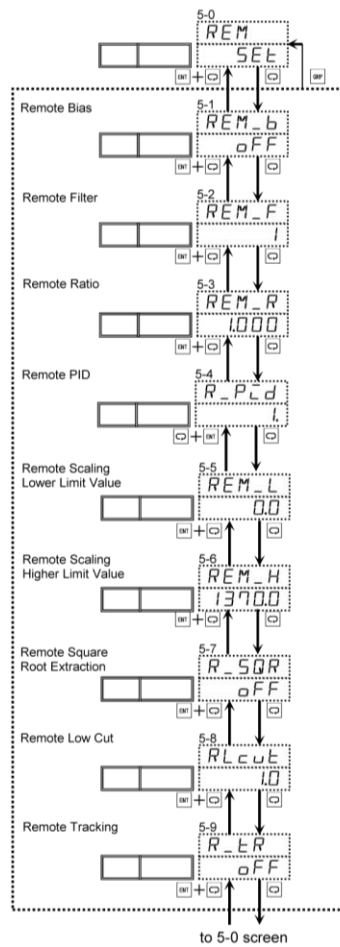

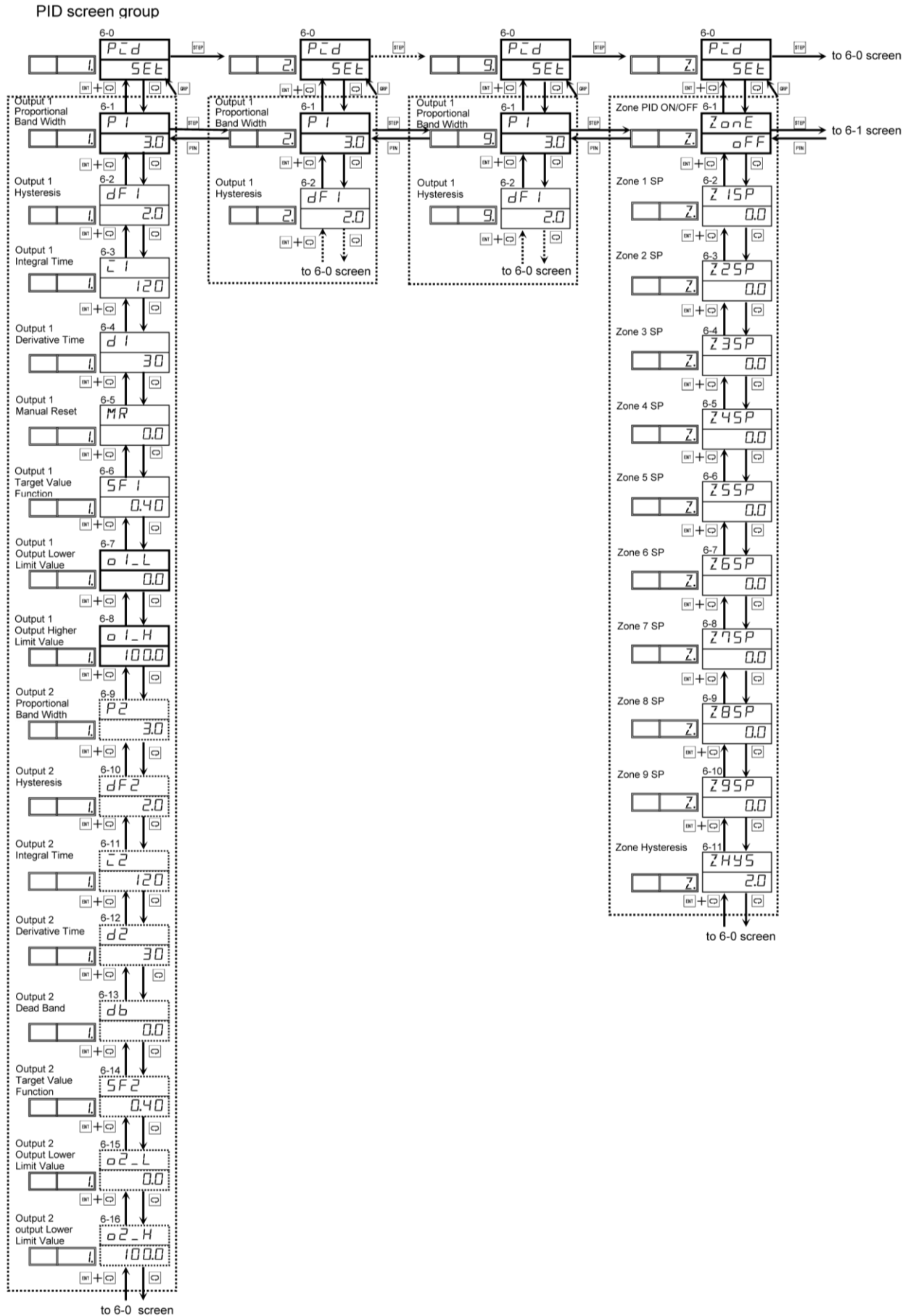



EV setting screen group

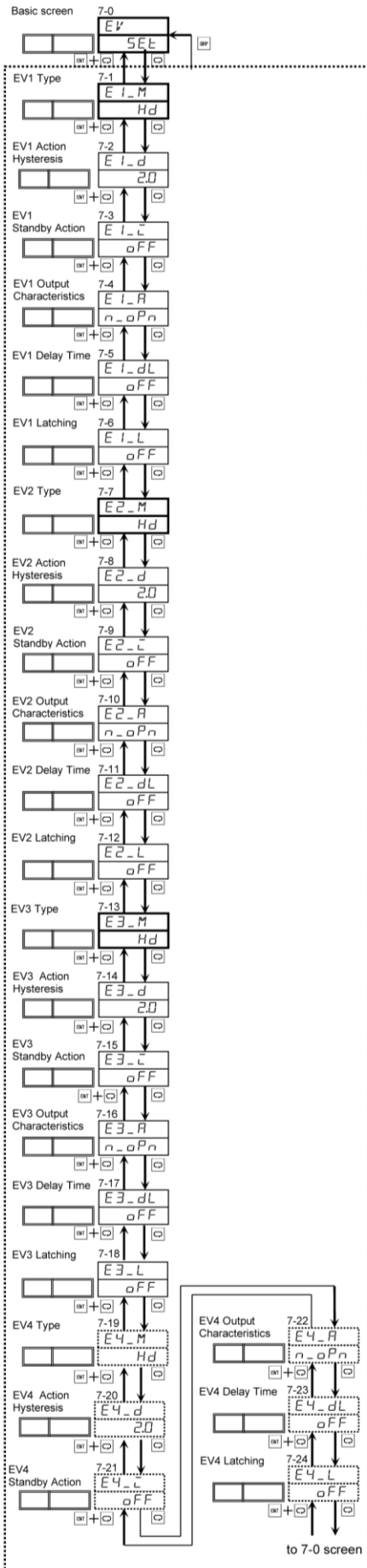

DO/DI screen group

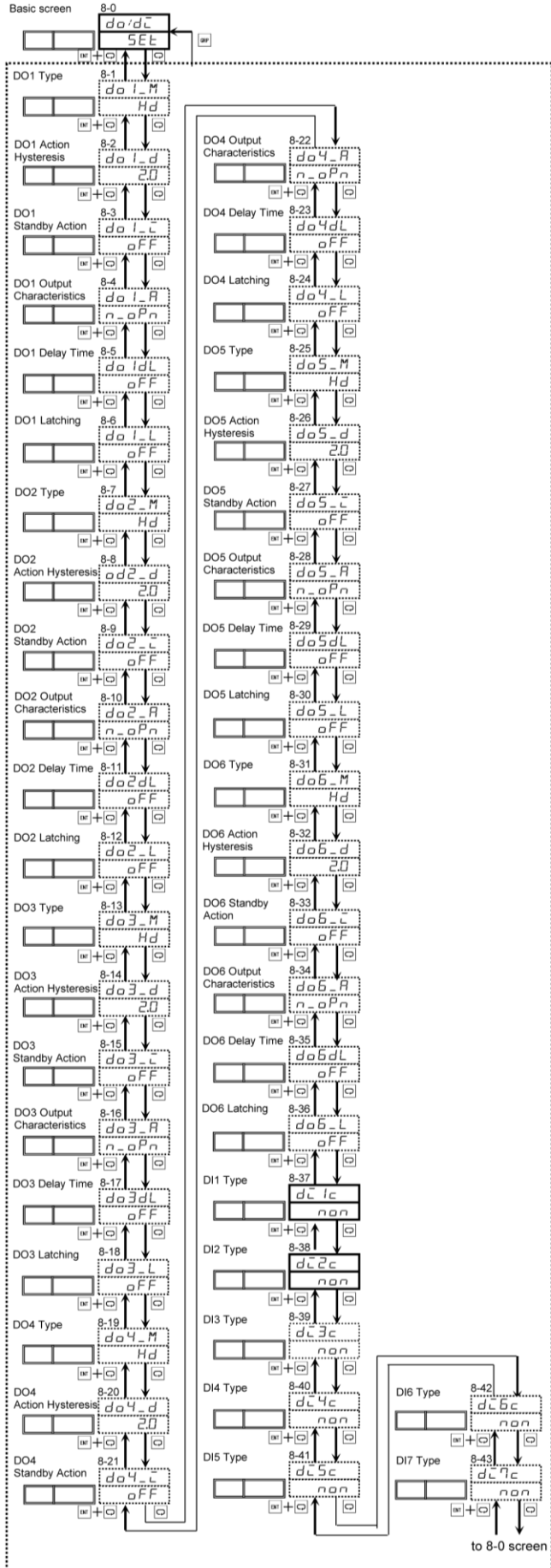



Communication setting screen group

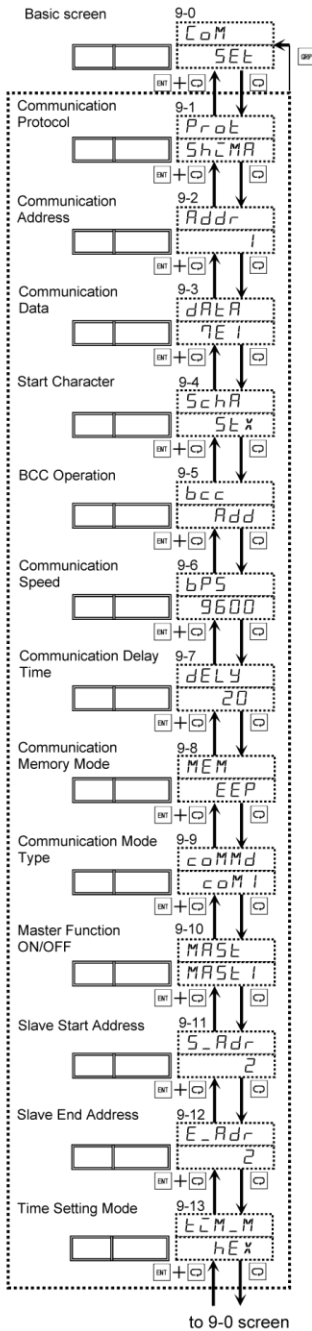

Analog output setting screen group

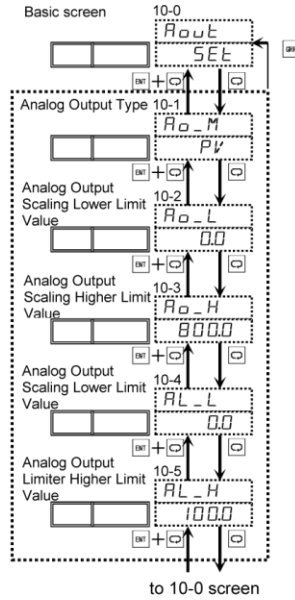

Heater Break/Loop Alarm setting screen Group

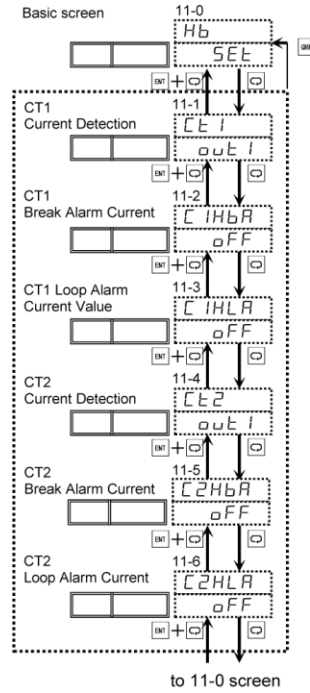

Control Output screen group

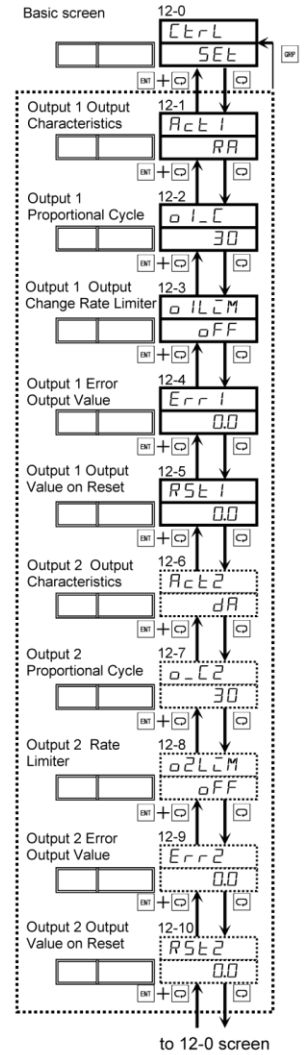

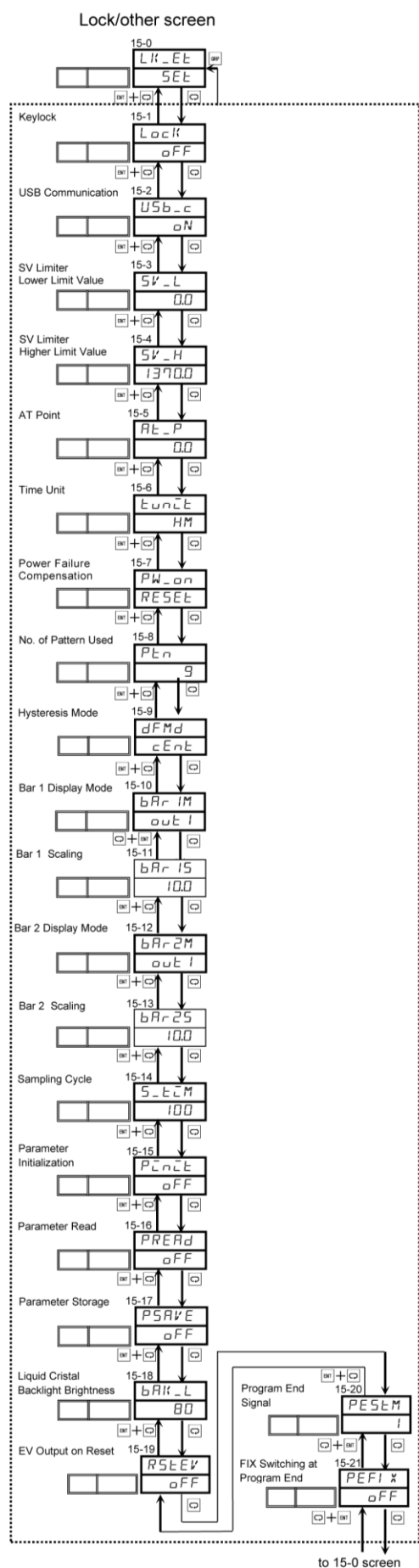
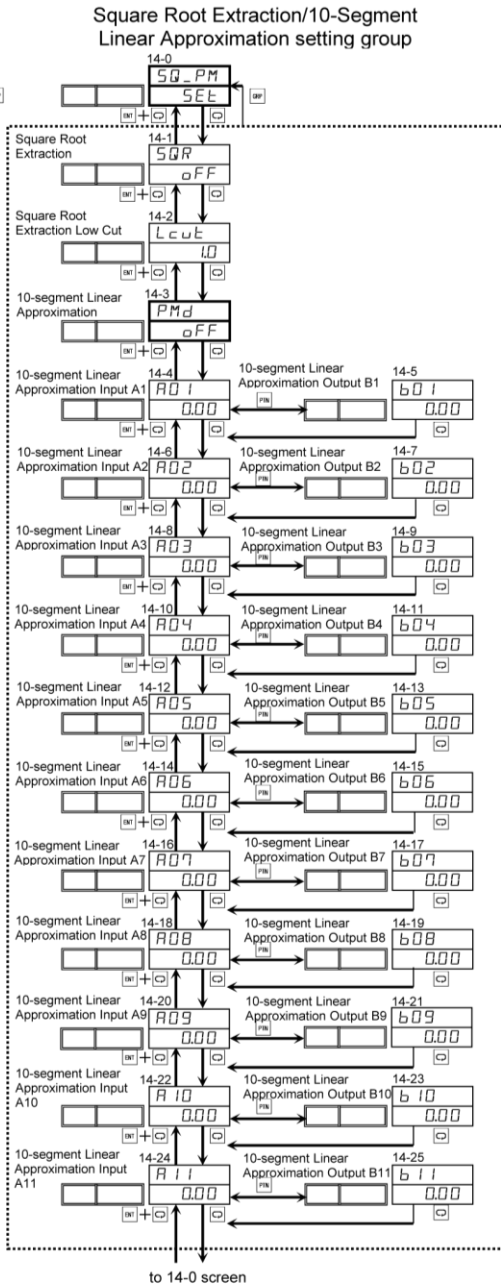
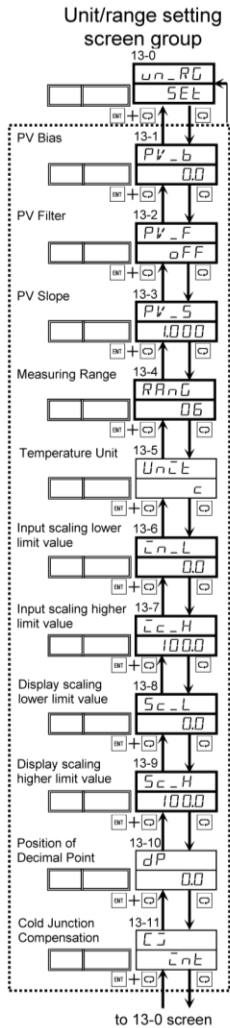



1 Installation and Wiring

1-1 Installation site of SRP30 Series



Caution

Please do not use this in any of the following places.

It may cause breakage of or damage to the instrument, and in certain instances, may cause fire.

- In places which generate inflammable gas, caustic gas, dust or smoke, or which are filled with these substances.
- In places exposed to water drops, direct sunlight, or radiant heat from other equipment.
- In places where ambient temperature is no more than -10°C or above 50°C.
- In places prone to water condensation or where humidity is no less than 90%.
- Near high-frequency equipment.
- Near a high-voltage power circuit and in sites that are prone to inductive interference.
- In places prone to strong vibration and shock.
- In places with an altitude of more than 2,000 m.
- Outdoor

1-2 External Dimensions and Panel Cutout of SRP30 Series

(1) External Dimensions

SRP33

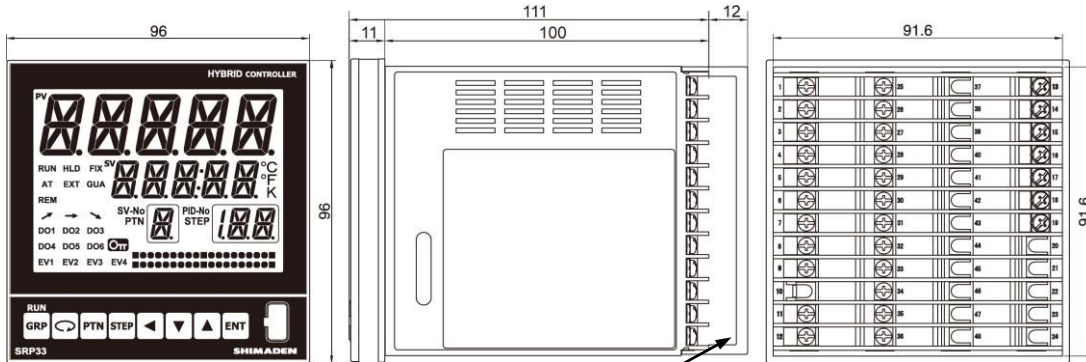

With terminal cover

SRP34

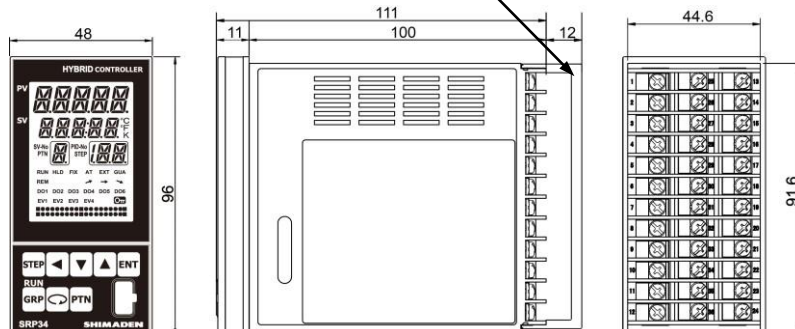

Unit: mm



1 Installation and Wiring

(2) Panel Cutout

SRP33

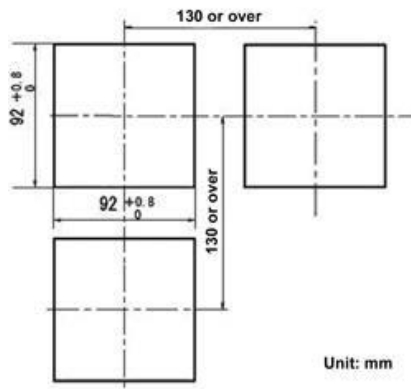

SRP34

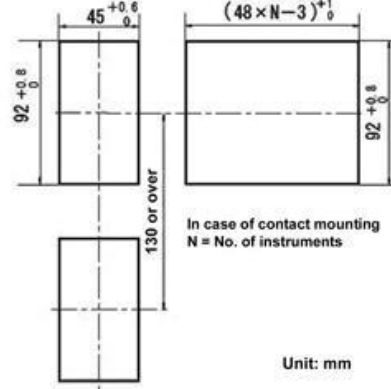

1-3 Panel Mounting Method for SRP30 Series



Caution

Do not disassemble this instrument to maintain safety and product functions. If it is necessary to disassemble the instrument to replace parts or repair it, please contact your nearest Shimaden dealer.

Be sure to install this product with the attached gasket. In case if the gasket is broken or falls off, please replace it with the designated one.

Follow the procedures below to mount the instrument onto a panel.

1. Prepare the mounting holes, referring to the panel cutout (1-2 (2)). The mounting panel applicable thickness is 1.0 to 8.0 mm.
2. Push the instrument from the panel front.
3. Insert mounting tool on the top and bottom of the instrument, and fix it by tightening the screw from the rear.
4. Excessively tightening the mounting screw can deform the case or cause damage. Please be careful not to tighten the screw too much.
5. After installation and wiring, please place into the terminal cover.

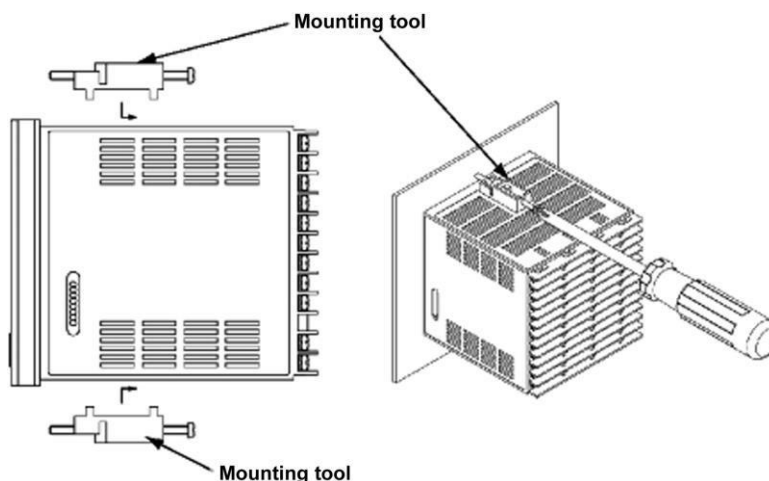



1-4 External Dimensions Of Current Sensor (CT) for Heater Break Alarm

CT is a product specification, and can be used upon selecting Heater Break Alarm. It is sold separately, and one may select any of the following.

(1) QCC01 for 0-30A

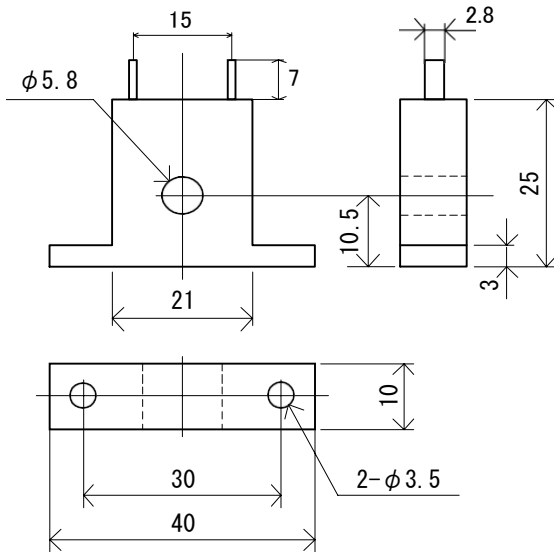

Unit: mm

(2) QCC02 for 0-50A

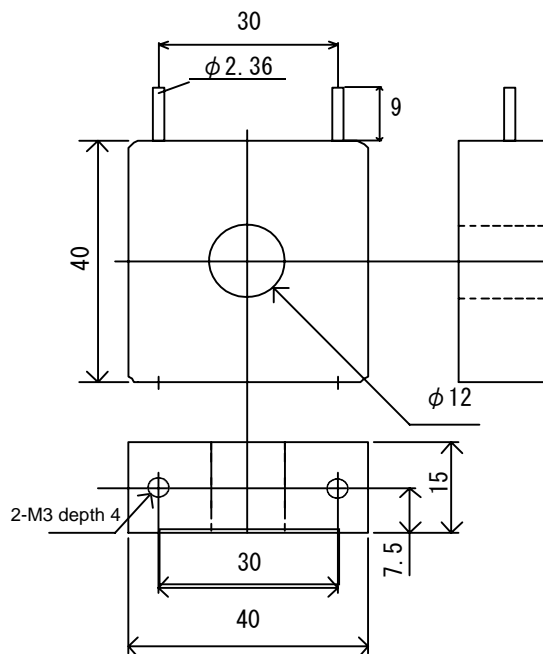

Unit: mm



1 Installation and Wiring

1-5 SRP30 Series Rear Terminal Arrangement

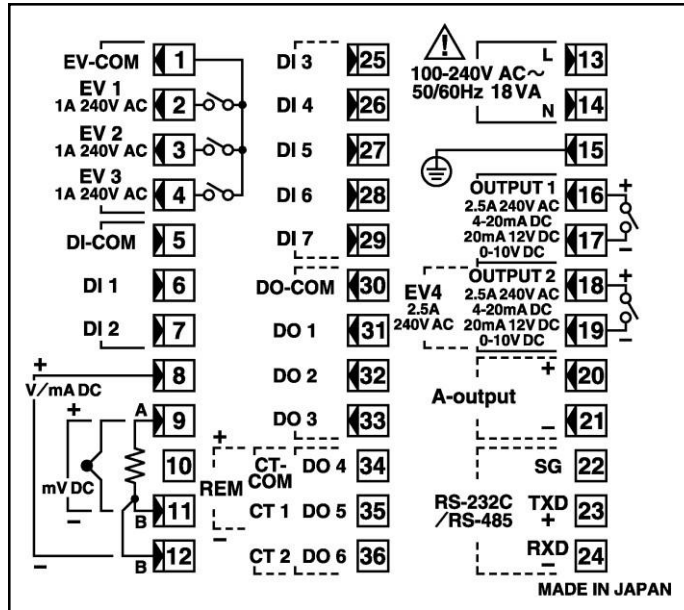

Terminal No.	Code	Terminal No.	Code	Terminal No.	Code
1	EV-COM	25	DI3	13	Power (L)
2	EV1	26	DI4	14	Power (N)
3	EV2	27	DI5	15	PE
4	EV3	28	DI6	16	OUT1+
5	DI-COM	29	DI7	17	OUT1-
6	DI1	30	DO-COM	18	OUT2+ EV4
7	DI2	31	DO1	19	OUT2- EV4
8	V+ mA+	32	DO2	20	AO+
9	mV+ A	33	DO3	21	AO-
10	CJ	34	DO4 CT-COM REM+	22	SG
11	mV- B	35	DO5 CT1 REM-	23	TXD +
12	B V- mA-	36	DO6 CT2	24	RXD -

Terminal screw: M3 screw (no more than 6.2 mm width)

* For current input (0–20 mA, 4–20 mA), connect a shunt resistor (QCS002) that is sold separately between terminal Nos. 8–12.

* Terminal arrangement for SRP34 is same as that for SRP33.



1-6 Wiring

Caution

- Do not turn on electricity during wiring work. There is a danger of getting an electric shock.
- Do not touch terminals and other live parts after wiring while the electricity is on.

Take caution on the following points while doing wiring work.

- Wiring must be according to “1-5 SRP30 Series Rear Terminal Arrangement,” and make sure not to create an incorrect wiring.
- Crimping terminal matches M3 screw. Please use one with no more than 6.2 mm width.
- In the case of thermocouple input, use a compensating lead wire that is compatible with thermocouple type.
- In the case of RTD input, the resistance value of each line of the lead wire should be no more than 10Ω, and the three lines have to have identical resistance value.
- Do not course input signal line through the same conduit tube or duct as a high-voltage power line.
- For static induction noise, use of a shield wire (single point grounding) is effective.
- For electromagnetic induction noise, twisting the input wire at short, equal intervals is effective.
- The cross-section area of the power supply wiring should be no less than 1 mm². For this you should use a power line or cable whose capacities are equivalent to those of 600 V PVC insulated wire.
- For ground wiring, use a power line that is no less than 2 mm² and use a grounding terminal no more than 100Ω.
- Countermeasure against lightning surge will be required for signal line over 30m.
- If this device is considered as being susceptible to noise caused by the power supply, attach a noise filter to prevent abnormal functioning.
Install a noise filter onto a grounded panel, and make the wire connecting the noise filter output and the power supply terminal on this controller as short as possible.

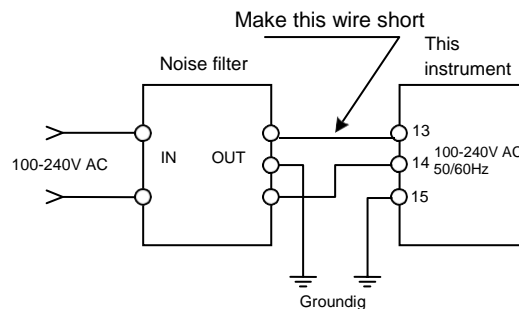

Recommended noise filter: TDK-made RSEL-2003W



2 Names and Functions of Front Panel

2 Names and Functions of Front Panel

Names and Functions of Front Panel (SRP33) as representative.

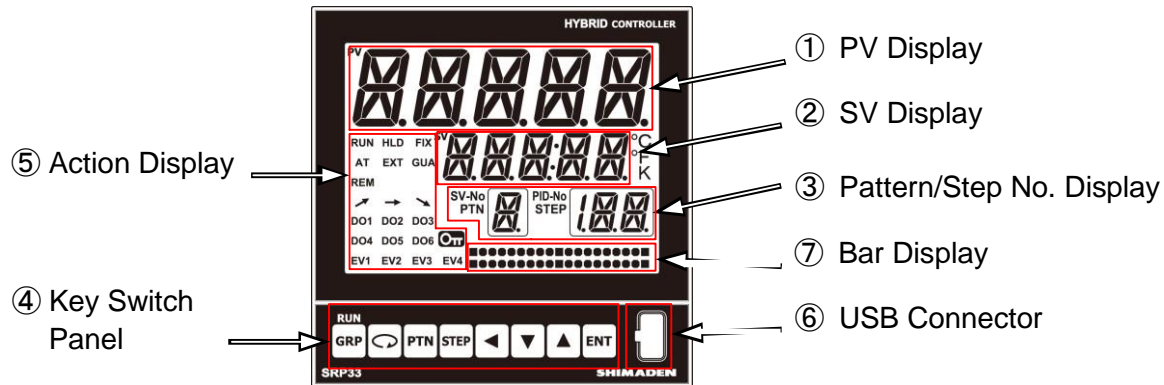

① PV Display

It displays measured value (PV value).
It displays a message when error (scaleover, etc.) occurs.

② SV Display

It displays target set value (SV value).

③ Pattern/Step No. Display

The following content is displayed.

- Pattern, Step No. Display: Displays Pattern/Step No. during program mode.
If zone PID is selected during PID mode, "Z" which shows zone PID is displayed in STEP.
- Various Set Parameters Display: Parameter selection display can be done through front panel key operation.

④ Key Switch Panel





The following 8 kinds of keys are fitted.

- GRP** Group Key: Set screen group move is executed.
(On the basic screen, RUN is executed by pressing **ENT** simultaneously.)
- ↻** Parameter Key: screen move is executed within every screen group.
- PTN** Pattern Key: Change of Set Pattern No. is done within the Pattern Setting Screen Group.
Change of Pattern No. to be executed is done.
- STEP** Step Key: Change of set Step No. is done within Step Setting Screen Group.
- ◀** Shift Key: Digit move for setting is done.
- ▼** Down Key: Subtraction of each screen set value is done.
- ▲** Up Key: Addition of each screen set value is done.
- ENT** Entry Key: Confirmation of each screen set value is done.



2 Names and Functions of Front Panel

⑤ Action Display

RUN	Green	Lights during control execution. Blinks during manual output. Lights out during reset.
HLD	Green	During program mode, lights when the program is on temporary stop. Blinks when the program is on temporary stop due to input abnormality.
FIX	Green	Lights during FIX mode. Lights out during program mode.
AT	Green	Blinks during auto-tuning execution, and lights when on standby.
EXT	Green	Lights when switching external Pattern No. and when specifying external SV No. and DI. Lights out when specifying key.
GUA	Green	Lights during execution of guarantee soak.
REM	Green	Lights during execution of Remote.
	Green	Lights during program operation and up-step execution.
	Green	Lights during program operation and flat-step execution.
	Green	Lights during program operation and down-step execution.
DO1	Orange	Lights during DO1 operation.
DO2	Orange	Lights during DO2 operation.
DO3	Orange	Lights during DO3 operation.
DO4	Orange	Lights during DO4 operation.
DO5	Orange	Lights during DO5 operation.
DO6	Orange	Lights during DO6 operation.
EV1	Orange	Lights during EV1 operation.
EV2	Orange	Lights during EV2 operation.
EV3	Orange	Lights during EV3 operation.
EV4	Orange	Lights during EV4 operation.
	Orange	Lights when displaying a parameter that cannot be changed due to keylock, etc.
PTN	White	Lights when displaying Pattern No.
STEP	White	Lights when displaying Step No.
SV-No.	White	Lights when displaying SV No.
PID-No.	White	Lights when displaying PID No.
°C	White	Lights when specifying Celsius.
°F	White	Lights when specifying Fahrenheit.
K	White	Lights when specifying Kelvin.

⑥ USB Connector

The front panel is fitted with a standard USB terminal. Communication between computer and USB can be done using a loader software. The SRP30 loader software and USB driver can be downloaded free of charge from our company website <https://shimaden.co.jp>.

Interface: USB 2.0 Micro B connector

Communication condition: Fixed

Communication Rate: 38400 bps

Communication Data Length: 8 bit

Parity : None

Stop bit: 1 bit

Communication Protocol: Shimaden Standard Protocol

⑦ Bar Display

Displays Output 1, Output 2, deviation, step time and execution frequency rate.



3 Action during Power Application, Screen Transition and Setting Operations

3 Action during Power Application, Screen Transition and Setting Operations

3-1 SRP30 Series Action during Power Application

When power is applied, the basic screen is displayed 3 to 4 seconds after initial screen is displayed on the LCD.

During the first time you apply power, check whether or not this is the product you want in every screen.

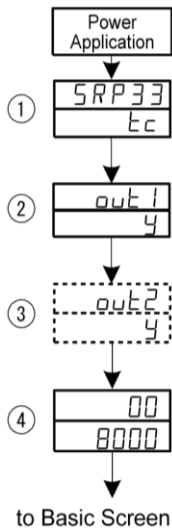

① Series Name Display, Input Type Display

Series Name Display: *SRP33, SRP34*

Input Type, Display Character: Thermocouple input: *tc*

RTD input: *Pt*

Voltage input: *MV, V*

Current input: *mA*

② Output 1 Type Display

Displays Output 1.

Output Type, Display Character: Contact: *C*

Current: *I*

SSR drive voltage: *P*

Voltage: *V*

③ Output 2 Type Display

Displays Output 2.

This is the screen displayed for added option.

Output Type, Display Character: Contact: *C*

Current: *I*

SSR drive voltage: *P*

Voltage: *V*

④ Measuring Range Display

Shows measuring range display.

Upper stage (PV Display): Measuring range lower limit

Lower stage (SV Display): Measuring range higher limit

The screen display content differs according to specifications or according to set function specifications.



3 Action during Power Application, Screen Transition and Setting Operations

3-2 Screen Display Switching Operation

(1) Switching Screen Display

For details of screen transition, please refer to “the Attached Key Sequence Diagram.”

The transition of operation screen of this instrument is configured so that when in usual usage condition, screen is displayed according to usage frequency.

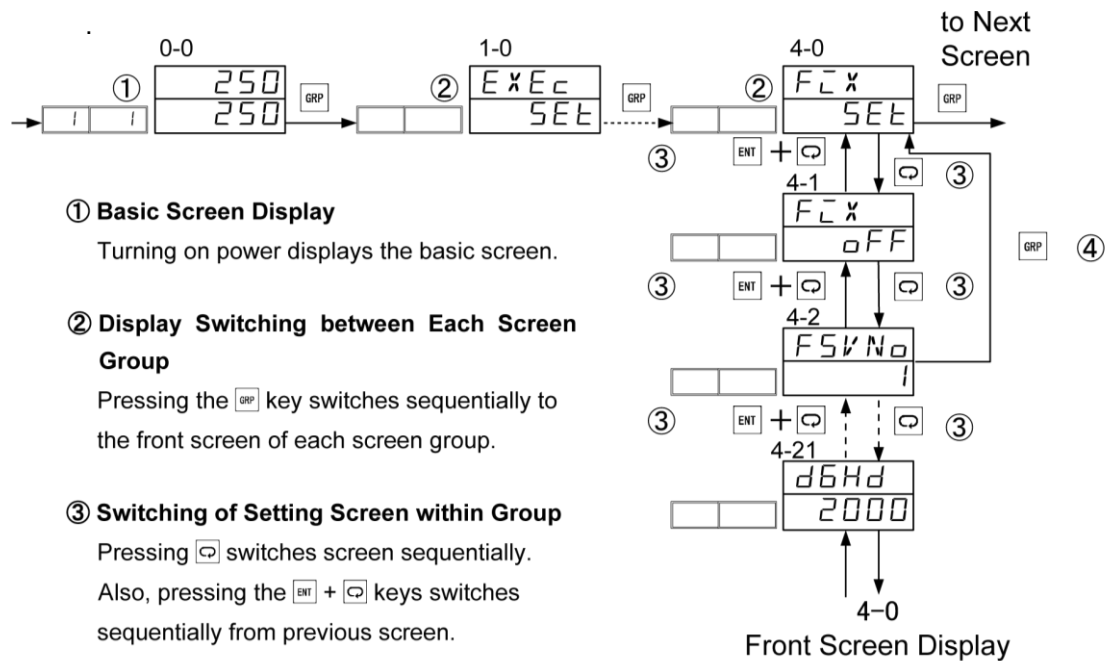

① Basic Screen Display

Turning on power displays the basic screen.

② Display Switching between Each Screen Group

Pressing the **GRP** key switches sequentially to the front screen of each screen group.

③ Switching of Setting Screen within Group

Pressing **[key]** switches screen sequentially.

Also, pressing the **ENT + [key]** keys switches sequentially from previous screen.

④ Display of Front Screen

Pressing the **GRP** key in every parameter setting screen, except basic screen group, switches to the front screen of every screen group. Also, pressing the **ENT + GRP** keys switches to the basic screen display.



3 Action during Power Application, Screen Transition and Setting Operations

3-3 Keylock Setting

(1) Keylock Screen Display

One can open the lock/other screen group (Group 15) from the basic screen by pressing the key.
One can also switch to the screen for setting and changing within the lock/other screen group screen by pressing the key.

One can select a parameter in the screen by pressing the key.

Furthermore, one can set a parameter by pressing the , , and key, and confirm the final registration by pressing the key.

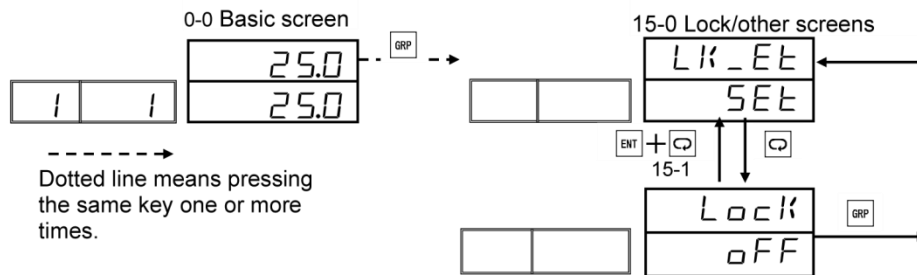

Dotted line means pressing the same key one or more times.

(2) Keylock

If one puts on the Keylock, a mark is displayed after transition to the parameter setting screen subject to lock, disabling setting and change.

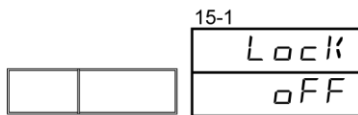

Setting range: oFF, 1, 2, 3
Initial value: oFF

- oFF: Keylock release
- 1: Parameter other than SV value, AT, MAN, EV/DO Action Point, RUN/RESET is put on keylock.
- 2: Parameter other than SV value is put on keylock.
- 3: All parameters are put on Keylock. (Except Keylock parameter)



3 Action during Power Application, Screen Transition and Setting Operations

3-4 Change and Registration of Various Data

Parameter setting and change is basically done by confirming screen display.

(1) Set Pattern Information

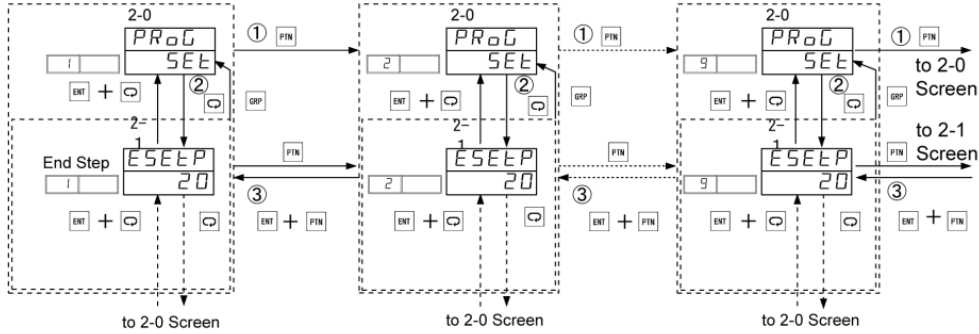

- ① When there are multiple Pattern Nos., press the **[PIN]** key.
- ② Pressing the **[ENT + CLR]** key on the selected Pattern No. changes the screen. Pressing the **[PIN]** key halfway through a screen changes it to the next Pattern No. screen.
- ③ Simultaneously pressing **[ENT + PIN]** returns one to the previous Pattern No. screen.

(2) Transition to Step Screen Group

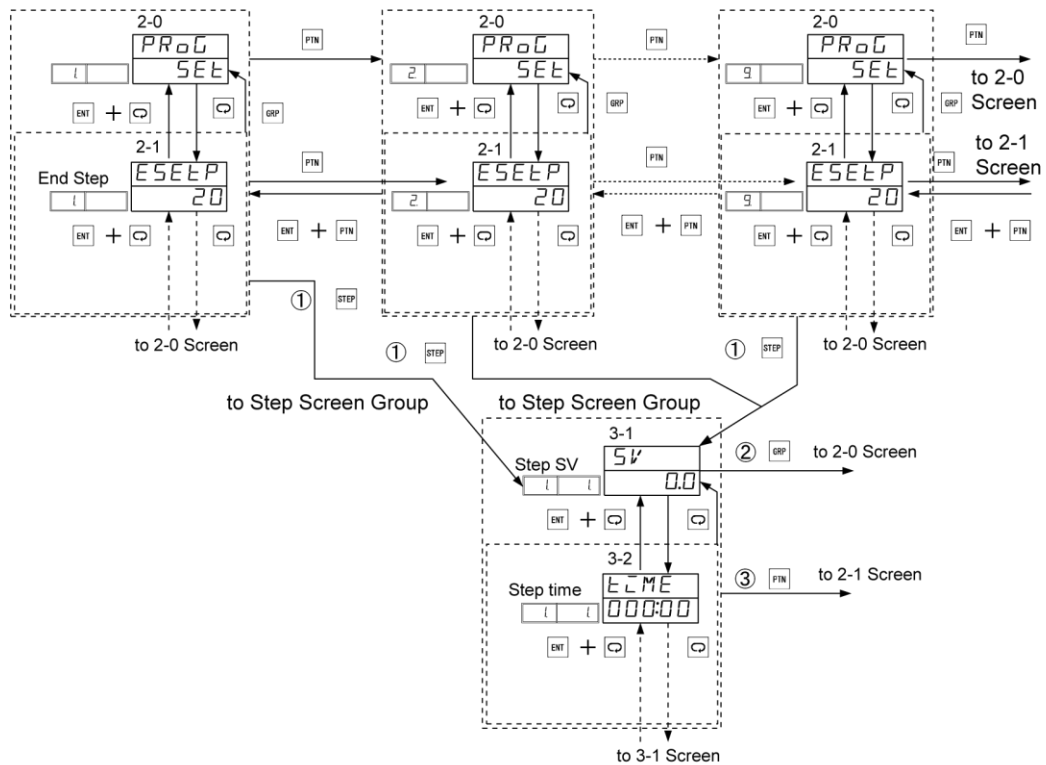

- ① Pressing the **[STEP]** key from the 2-0 Screen changes it to the 3-1 Step SV Screen.
- ② Pressing the **[GRP]** key on the 3-1 Step Screen returns the 2-0 Program Basic Screen.
- ③ Pressing the **[PIN]** key from each pattern screen returns the 2-1 End Step Screen.



3 Action during Power Application, Screen Transition and Setting Operations

(3) Setting Step Information

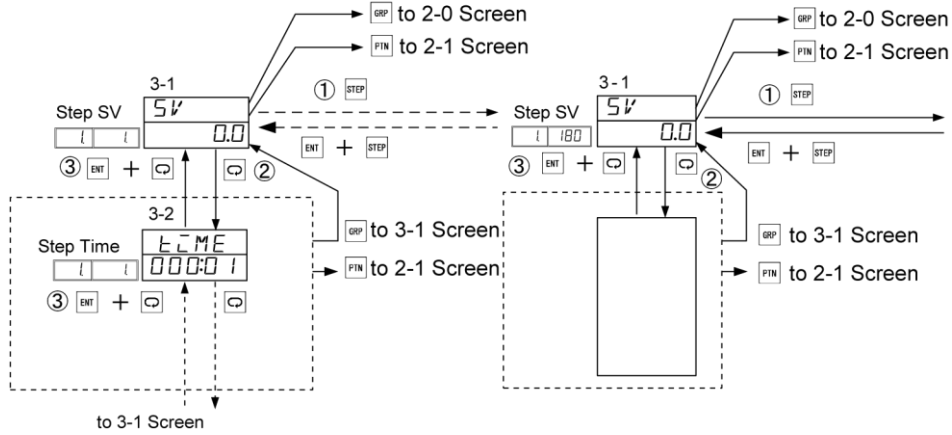

- ① When there are multiple Step Nos., press the **STEP** key.
- ② Same as in the case of Pattern No., the **ENT** key changes the screen. Pressing the **STEP** key halfway through a screen changes it to the next Step No. screen.
- ③ Simultaneously pressing the **ENT** + **ENT** keys returns one to the previous Step No. screen.



4 Control Output Setting

4-1 Control Mode of the SRP30 Series

There is a "Program Mode" which performs program control and a "FIX Mode" which performs fixed value control in the SRP30 Series.

The status transition between both modes is shown in the following figure.

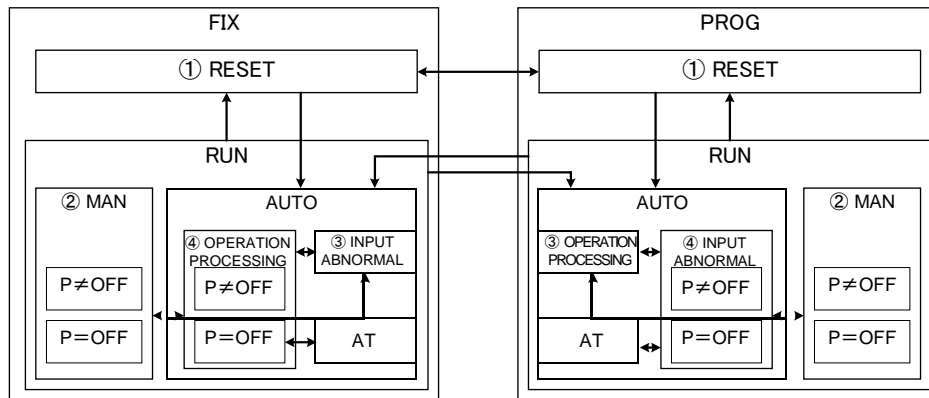

* Output priority is in succession order from ① to ④.

Pressing the **ENT** + **GRP** keys on the basic screen switches between RESET and RUN.

4-2 RESET/RUN Status of Output Action Mode

FIX mode RESET status (RESET status)

- Control Output: Output Value during RESET
- Event Output: Alarm event is not output (Status is output.)
- Action Display RUN: Stops flashing
- RESET/RUN Switch: Switches over to FIX execution status
- Analog Output: During SV selection, FIX: Execution SV Value is output.
- FIX OFF: Switches over to PROG Mode RESET status

FIX Mode RUN status (Execution status)

- Control Output: Result of operation result in Execution PID processed by output limiter
- Action Display RUN: Lights
- RESET/RUN Switch: Switches over to FIX RESET status
- FIX OFF: Switches over to PROG Mode, control starts from Start SV (AT and MAN are released)
(Starts from Start Step-1 Step SV when Start Step is specified)

PROG Mode RESET status (RESET status)

- Control Output: Output Value during RESET
- Event Output: Alarm event does not output (Status outputs)
- Action Display RUN: Stops flashing
- RESET/RUN Switch: Switches over to PROG execution status
- Analog Output: During SV selection, FIX: Execution SV Value is output.
- FIX ON: Switches over to FIX Mode RESET status



PROG Mode RUN status (Execution status)

- Control Output: Result of operation result in PID specified by Execution Step No. processed by output limiter
- Action Display RUN: Lights
- RESET/RUN Switch: Switches over to PROG RESET status
- FIX ON: Switches over to FIX Mode Execution Status (AT, MAN are released)





4 Control Output Setting

4-3 Manual Control Output (MAN)

Pressing  for 3 sec. on Output Monitor Screen switches from automatic output to manual output. (Pressing the + keys quickly also effects the transition.) Also, changing from automatic (AUTO) to manual (MAN) leads to balanceless bumpless action, and the immediate prior automatic output value is succeeded by manual.

4-4 Automatic Control Output (AUTO)

Pressing  for 3 sec. in manual control status returns manual output back to automatic output. (Pressing the + keys quickly also effects the transition.) Also, when changing manual (MAN) to automatic (AUTO), bumpless action becomes inoperative if the PV value is outside the proportional band.

4-5 Output Limiter

One can set the output limiter for every PID No. used.
If the post-PID operation output value exceeds the output limiter range, it will be restored to the value within the output limiter range.

4-6 Output Change Rate Limiter

This is set when using an operation terminal that dislikes drastic output change.

4-7 Proportional Cycle

Proportional cycle during contact and SSR drive voltage output can be set at 1–3000 sec.
When AT is in execution, the proportional cycle is inoperative during P = OFF, RESET.

4-8 Power Failure Compensation

By specifying the power compensation parameter, one can select an action during power failure recovery.
RESET (R E S E t): recovering under RESET status
Continue (c o n t): recovering status immediately before power interruption



5 Setting SRP30 Series

5-1 Parameter Setting Procedure

When using this for the first time, or changing operation parameter currently in use, or changing the object device for control, it is necessary to change the setting of this instrument following the procedure below.

Caution

Depending on the operation, the parameter setting can revert to the factory setting. Before initializing, record and save the setting content as necessary.

For customers who are not device manufacturers, please use the functions only upon understanding them sufficiently, and perform operations and settings as explained below.

The basic functions and setting method of this instrument are explained from Chapter 6 and described in accordance with programming procedures.

Furthermore, when option functions are not mounted or when function is not selected, some screens and parameters are not displayed.

For the whole picture of operation screens and screen transition, refer to the attached “Key Sequence Diagram,” and for setting parameters, refer to “24 Parameter List.”

Caution

When changing range, scaling or decimal point position, related parameters may also be initialized. When changing any of these, please reconfirm the other parameters as well. For parameters that have the possibility of being initialized, please refer to the “24 Parameter List.”



6 Various Monirot Screens Group

6 Various Monitor Screens Group

Perform setting of various monitor screens group.

6-1 RESET/RUN Switch

Perform RESET/RUN switch.

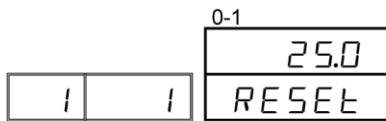

Setting range: RESET, RUN
Initial value: RESET

Note

- When assigning RUN 1 to DI, key operation is not allowed because DI is prioritized. Only monitor is possible.

6-2 Output Monitor and Manual Output

Perform setting of Output 1 Monitor (0-2 Screen), Output 2 Monitor (0-3 Screen) and Manual Output.

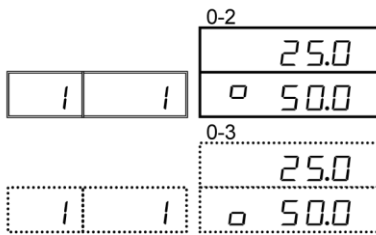

Setting range: Manual Output 0.0%–100.0%

Note

- Switching from Automatic Output to Manual Output is done by pressing **ENT** for 3 sec. or **ENT** + **▲**.
- Switching to Manual Output is not allowed during Auto-tuning or RESET.

6-3 Execution PID No. Monitor

Execution PID No. Monitor is displayed.

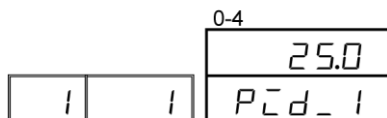

Execution PID No. Display

Note

- There is no display when program is not in execution.
- When switching to RESET status while screen is displayed, screen reverts to the basic screen.



6 Various Monirot Screens Group

6-4 Monitor of Remaining Time of Step

Remaining Time of Step is displayed on monitor.

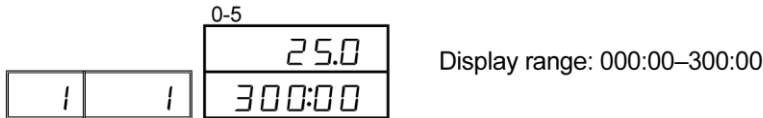

Note

- There is no display when program is not in execution.
- When switching to RESET status while screen is displayed, screen reverts to the basic screen.

6-5 Monitor of No. of Pattern Executions

No. of Pattern Executions is displayed on the monitor.

The current No. of times of execution of the pattern being executed is displayed.



Note

- There is no display when program is not in execution.
- When switching to reset status while screen is displayed, screen reverts to the basic screen.

6-6 Monitor of No. of Step Loops

No. of Step Loop Executions is displayed on monitor.

The current No. of times of step loop execution is displayed.

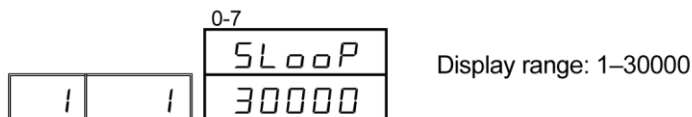

Note

- There is no display when program is not in execution.
- When switching to reset status while screen is displayed, screen reverts to the basic screen.



6 Various Monirot Screens Group

6-7 Pattern Link Monitor

(1) Pattern Link Monitor

Current execution position of the set pattern link is displayed.



Note

- There is no display when program is not in execution.
- When switching to RESET status while screen is displayed, screen reverts to the basic screen.

(2) Monitor of Repetition No. of Pattern Link

Current No. of times of execution of pattern link is displayed.



Note

- There is no display when the program is not in execution.
- There is no display when pattern link is OFF.
- When switching to reset status while screen is displayed, the screen reverts to the basic screen.

6-8 Heater Current Monitor

Heater current 1 (0-10 Screen), Heater current 2 (0-11 Screen) is displayed.

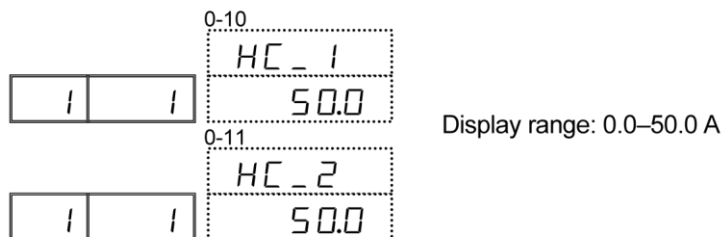

- Heater current value changes with every control cycle, and when CT current value is invalid, - - - - - is displayed.
- When CT detection current value exceeds 110% (55.0 A), EE_HH is shown on the display screen.
- When CT detection current value drops below -10% (-5.0 A), EE_LL is shown on the display screen.

Note

- When heater current is on invalid status, - - - - - is displayed.

6-9 Remote Input Monitor

Remote input is displayed.

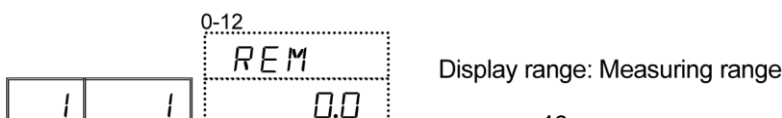



7 Setting EXEC

7-1 Automatic/Manual Switching of Control Output

Control Output can be switched to either automatic or manual.

Usually, one performs automatic operation but when testing the overall equipment including the SRP30 series and other instances, one may set control output to manual.

During Manual Output, please take note that Control Output continuously outputs value as set and does not perform feedback control.

During Manual Output, the Action Display RUN monitor lamp blinks.



MAN Execution Condition (Common input for front key and external switch) is as follows.

(1)Not in AT execution (AT = ON).

(2)Not in reset status (RESET).

Note

- When assigning MAN to DI, key operation is not allowed because DI is prioritized. Only monitor is possible.

7-2 Latching Release Setting

To release latching, set latching.

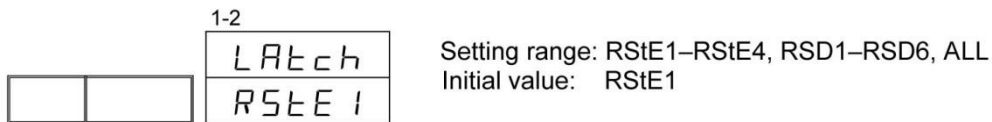

RStE1–RStE4: latching release of EV1–EV4

RSD1–RSD6: latching release of DO1–DO6

ALL: release of all latching

Note

- Only event and DO in which latching is set at ON are displayed.



7 Setting EXEC

7-3 Setting Communication Mode

Sets Communication Mode (COM).

Through communication from the host side, anything set to COM mode can be changed to local mode. In COM mode, change through key operation is not allowed.

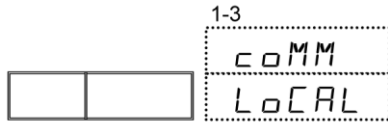

Setting range: LoCAL, CoM
Initial value: LoCAL

Local mode (LoCAL)

Parameter data change and setting is possible through the front panel key.

In communication, only read command is valid while write command is invalid.

However, LOCAL → COM command is an exception.

COM Mode (CoM)

Parameter data change and setting is possible through communication.

Parameter change and setting are not allowed through the front panel key.

However, COM→LOCAL setting through key operation is an exception.

Note

- When communication mode is on COM, change through key operation of parameters other than communication mode is locked.
- When communication mode type is COM2, it is displayed.
- Only COM → LOCAL change is allowed through key operation.

7-4 Temporary Hold and Restart of Program

With the temporary HLD function of action during program execution, one executes HLD by setting ON, and releases HLD by setting OFF.

Also, while HLD is in execution, the HLD monitor lamp lights.

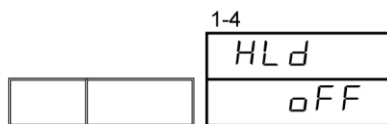

Setting range: oFF, oN
Initial value: oFF

In the example below, it is controlled so that when HLD is released, SV5 is achieved in the remaining time of Step 5.

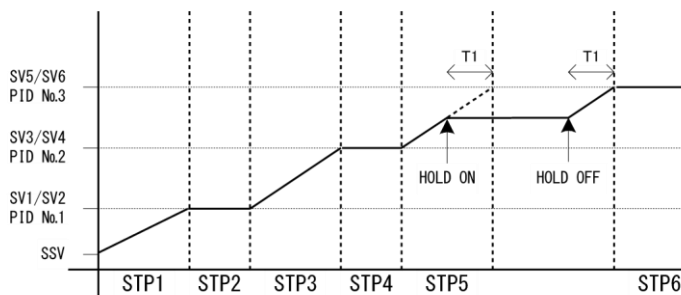

- * 1 HLD is valid even during guarantee soak.
- * 2 ADV is not allowed during HLD.
- * 3 HLD operation by key input and communication is valid when there is no DI assignment. (DI input priority)
- * 4 If program is executed through HLD DI input ON, it will depend on SV value of PV Start function.
Example) When PV Start is ON, hold is executed through SV value of PV Start.
When PV Start is OFF, hold is executed through start SV.
- * 5 During HLD, change in start SV, step SV and parameters related to time signal will not be reflected until HLD is released.



7-5 Executing Advance

During program operation, one can forcibly switch over to the front of the next step. There is no display when not in execution. Also, switching over to RESET status during screen display reverts to the basic screen.



Note

- If assigned to DI, only monitor is allowed.

(Example) In step transition through ADV (forcibly terminating Step 5 and moving to Step 6), program is omitted. This is valid during program execution.

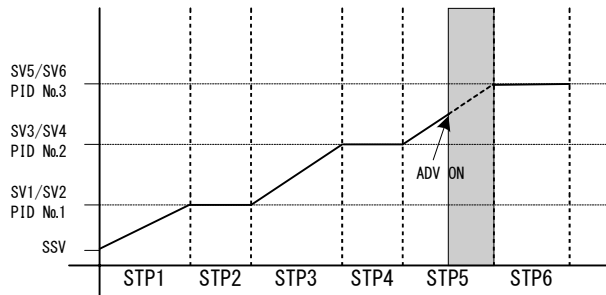

Shaded part is removed and Step 6 control begins.

Note

- Executing ADV once makes ADV input invalid for about 2 seconds.
- After changing step, ADV input is invalid for about 1 second.

7-6 Execution and Termination of Auto-tuning

One can execute/terminate Auto-tuning (AT).



Caution Points of Auto-tuning

This is done to find optimum PID value in order to perform PID operation control. When in program mode, AT is not performed during slope execution. But exception is if there is HLD input during slope execution. Moreover, in flat parts, even during HLD status, if P of executed PID No. is OFF, AT is on standby. AT can be terminated through End Step even if No. of program executions is set to no less than 2. Also, if AT is completed for all PID No. before End Step, AT is terminated at that point.



7 Setting EXEC

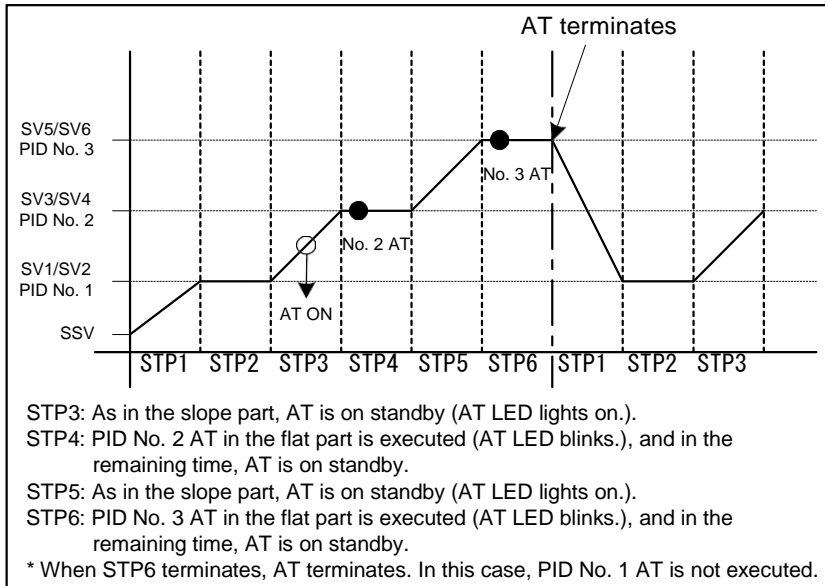

In flat parts (including when on HLD), AT LED blinks if AT is actually executed. Other than this, it lights until End Step. However, AT terminates if the following conditions arise.

- ① If status changes to RESET.
 - ② If AT action is terminated through key action or communication.
 - ③ If during AT execution, each half-cycle exceeds 200 minutes.
 - ④ If PV value scaleover occurs.
 - ⑤ If AT from No. 1 to No. 9 is terminated. (During PROG)
- * If in the flat part, STEP time is not enough and AT does not terminate, AT execution at that No. will be carried over to the next. But this will be only up to End Step.
 Basically, parameter change processing cannot be done during AT execution, but can be done only during standby.

AT at 2-output specification is as follows.

- ① During heating/cooling, cooling/heating action, PID value of both OUT1 and OUT2 are the same.
- ② During heating/heating, cooling/cooling action, only OUT1 performs AT, and OUT2 output during AT is 0% (output limiter lower limit).(The PID value of OUT2 cannot be changed.)

Conditions in which AT is valid are as follows.

- ① It is in Automatic Output mode.
- ② Output 1 execution PID No. P ≠ OFF. (In case of FIX mode)
 If in PROG mode, AT can start regardless of executed PID No. P value, but if Output 1 executed PID No. P = OFF, AT will be on standby.
- ③ PV value is not in scaleover.
- ④ Zone PID is not PV.



7-7 Pattern Link Related Setting

(1) Start Pattern No. Setting

Sets the front pattern No. when executing a program.

This screen does not belong to program screen group but to EXEC screen group.

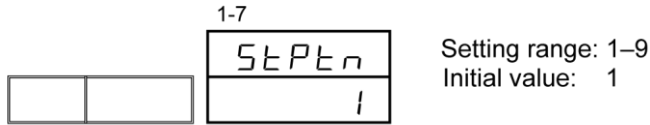

Note

- This parameter can be set on the basic screen using PTN key immediately before program control execution.
- If there is a Start Pattern No. halfway through the link, one can start the program halfway through the link.
- If there are multiple Start Pattern No. during the link, one can start the program from the lower link No.

(2) Setting No. of Pattern Link Repetition

Sets No. of pattern link executions.

A linked pattern can be executed repeatedly from 1 to 30000 times.

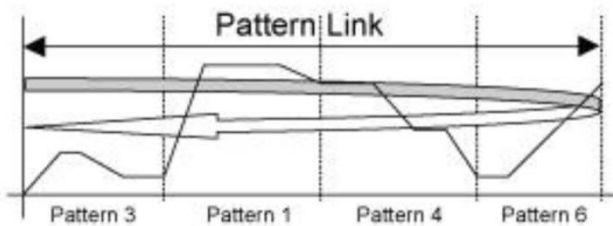

Note

- If No. of pattern link is set to OFF, the link function will not work.



7 Setting EXEC

(3) Pattern Link

This setting is to link (connect) every pattern in operating a program.

Please set Pattern No. one wants to link sequentially from the 1st.

One can link 1st to 10th, with 10 as the maximum.

Also, it is possible to set the same pattern any No. of times.

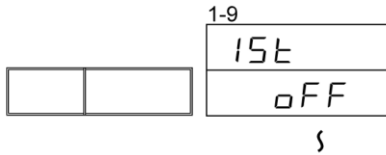

Setting range: oFF, 1-9

Initial value: oFF

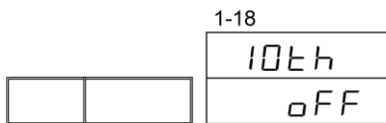

Note

- If one sets each Pattern No. from pattern 1st to 10th to OFF, any link to a pattern set after that will become invalid.
- During program execution, only a monitor is allowed.



8 Program Setting

8-1 Setting Related to Pattern

(1) End Step

Sets No. of steps to be used in a program pattern.

2-1

1.			E S T E P
			20

Setting range: 1–180

Initial value: 20

This operation is executed after engaging control action to stop status (RESET).

Maximum No. of Steps varies with No. of Patterns to be used.

No. of Patterns	1	2	3	4	5	6	7	8	9
Maximum No. of Steps	180	90	60	45	36	30	25	22	20

(2) Start Step

Sets Start Step during program.

2-2

1.			S S T E P
			1

Setting range: 1–End Step (No. of Steps)

Initial value: 1

Note

- This parameter can also be set on the basic screen immediately before program control execution.

For details, please refer to “22-1 Operation on Basic Screen.”

(3) Start SV

Sets SV value when you start the program.

Start SV function is valid only if program is started from Step 1.

2-3

1.			S T R S V
			0.0

Setting range: Within SV Limiter Setting range

Initial value: 0.0

Note

- This parameter can also be set on the basic screen immediately before program control execution.



8 Program Setting

(4) No. of Pattern Executions

Sets No. of program pattern executions. If during program execution the No. of pattern executions one sets is less than the current No. of pattern executions, program pattern will terminate after you execute until End Step. (If pattern link is accomplished, it will switch over to the next pattern.)

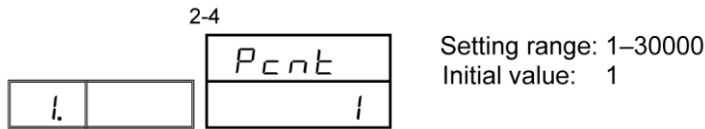

(Example) If you set No. of Pattern Executions to 3 at Pattern 1 (set from Step 1 to 4)

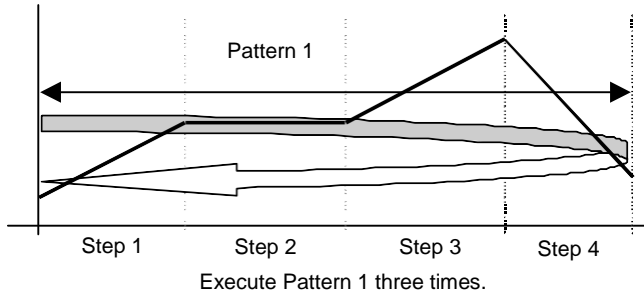

(5) Start Step No. of Step Loop

Sets Start Step No. during step loop.

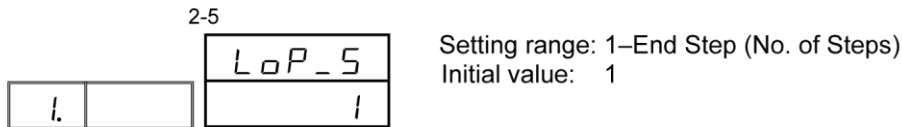

(6) End Step No. of Step Loop

Sets End Step No. during step loop.

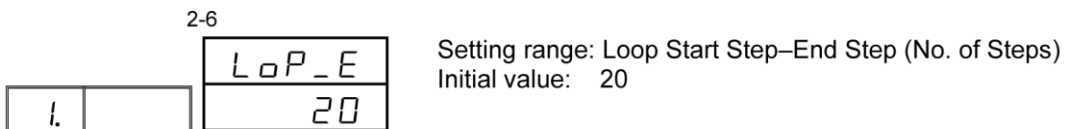

(7) No. of Step Loop Executions

Voluntary step intervals can be executed repeatedly from 1 to 30000 times.

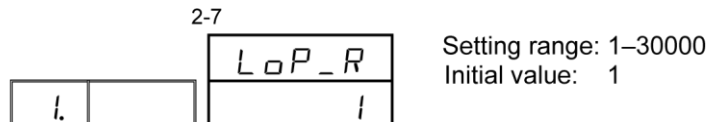

(Example) If you set No. of Executions to 3 at Start Step No. 2 and End Step No. 5

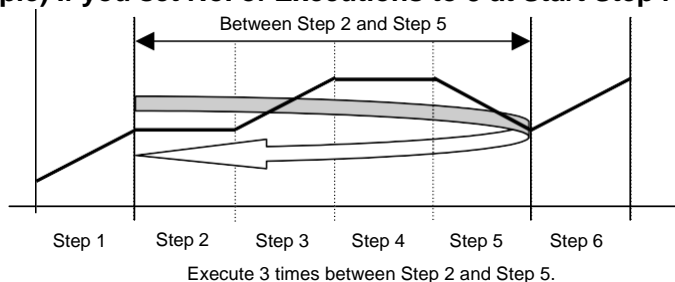



(8) Guarantee Soak Zone

Sets Guarantee Soak Zone.

The set value is the deviation with respect to the flat step SV value.

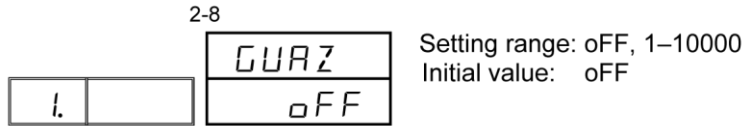

What is Guarantee Soak (GUA)?
 During program control, when SV value moves from slope step to flat step, PV value may not be able to follow due to the control system and flat step time can become shorter. This function is used to avoid the above and guarantee flat step time.

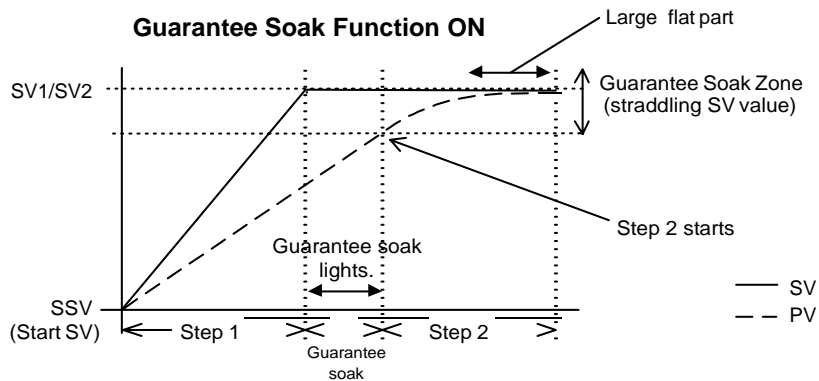
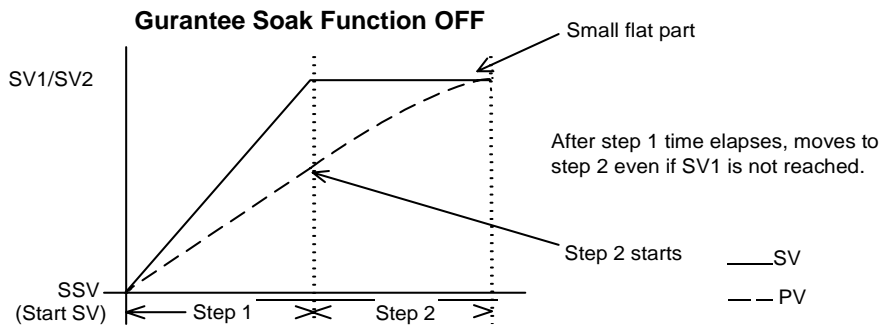

When switching from slope step to flat step, if the deviation between Step SV and PV value of flat step is not placed in the Guarantee Soak Zone, it will not move to the next step and will be on standby until guarantee soak zone is attained.

During standby, the guarantee soak lamp lights up on the screen action display.



8 Program Setting

(9) Guarantee Soak Time

Sets Guarantee Soak Time. Terminate slope step time while simultaneously taking time measurement, and if the set time is attained, it will switch over to flat step regardless of whether inside or outside of the Guarantee Soak Zone.

However, if set at 000:00, guarantee soak continues until PV value reaches Guarantee Soak Zone.

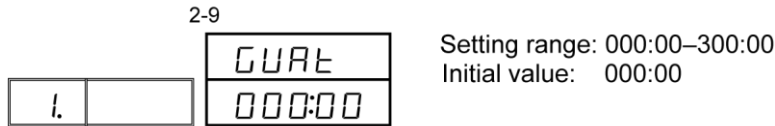

- If PV value lag in respect to SV value is big

If Guarantee Soak Zone is not reached even after step 1 had lapsed, guarantee soak continues until Guarantee Soak Zone is reached. However, if Guarantee Soak Time is set, even if guarantee soak zone is not reached, guarantee soak is terminated once Guarantee Soak Time lapses and the next step starts.

If Guarantee Soak Time is 000:00

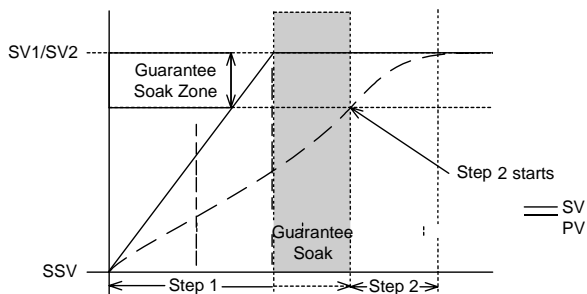

If Guarantee Soak Time is set

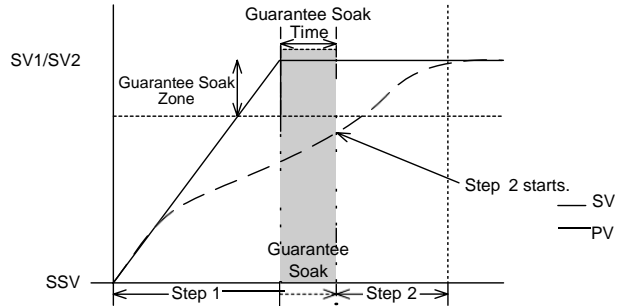

Note

- During RESET → PROG, even if step 1 is flat (SSV = SV1), guarantee soak is performed.
- Also, even if 000:00 is set for step time, if conditions match, guarantee soak is performed.
- In the old model (FP23, etc.), Guarantee Soak Time is up to a maximum count of 9999, but in the SRP30 Series, the function has been enhanced to a maximum count of 30000. In the old model, when this parameter is processed by communication, it is converted into BCD. If in 16 bit data length BCD, maximum value expressed is 9999, but in the SRP30 Series, value exceeding 9999 is assumed so BCD is not used. For this reason, in the SRP30 Series, Guarantee Soak Time processed by communication is in HEX value. In HEX, communication compatibility with old models is lost but it has the merit of being able to process values above 9999. On the other hand, if compatibility is prioritized, use of BCD similar to the old one is also possible, but maximum value is limited to 9999 as stated earlier. One can select setting between 2 types, HEX mode and BCD mode, through time setting mode setting. Also, when changing time setting mode from HEX to BCD, step time set to 100:00 and above is initialized at 99:59. For details regarding time setting mode, please refer to “15-3 (12) Time Setting Mode.”



8-2 PV Start

If the Start Step during program execution is on slope control and the Start SV Value and PV Value are markedly different, waste of action time arises. In order to shorten this dead time, PV Value is set as Start SV Value to commence action. If PV start is OFF, execution always starts with start SV.

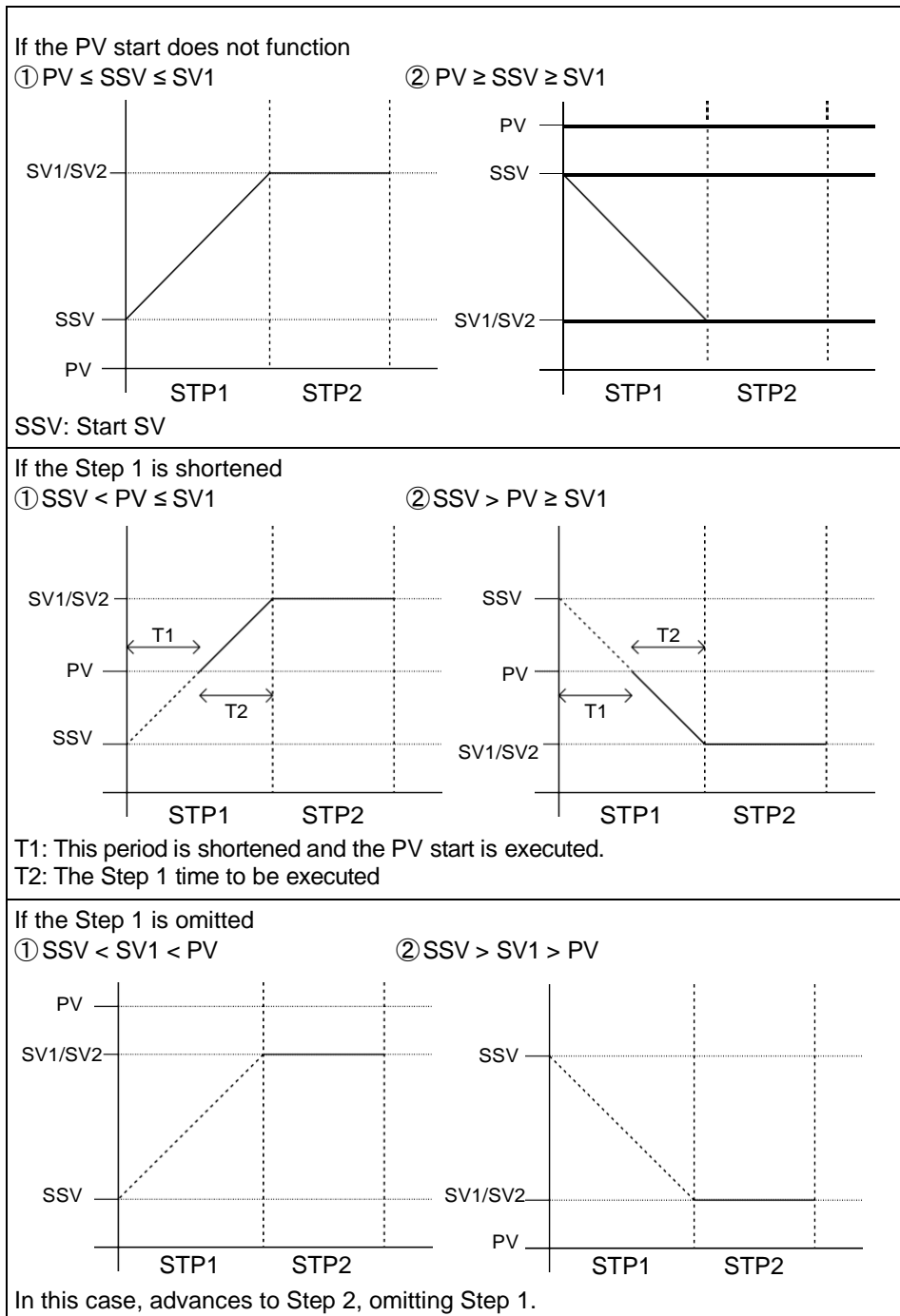
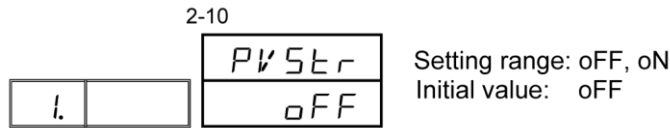

* 1 PV start is valid only if Start Step time is set to no more than 000m01s.

* 2 For reasons of resolution of the inside of this instrument, if one operates PV start function under conditions of high value for short-time step setting and step SV change rate, there is danger that an accurate SSV (Start SV Value) will not be calculated.



8 Program Setting

8-3 Program EV, DO Level (Action Points)

Sets every EV and DO level (action point) in the program mode.

2-11

E 1Hd
2000.0

2-12

E 2Ld
-199.9

2-13

E 3Hd
30000.0

2-14

E 4Ld
30000.0

2-15

do 1Hd
30000.0

2-16

do 2Hd
30000.0

2-17

do 3Hd
30000.0

2-18

do 4Hd
30000.0

2-19

do 5Hd
30000.0

2-20

do 6Hd
30000.0

Alam type	Initial value	Setting range	Display character column
Higher limit absolute value	Measuring range higher limit value	inside measuring range	△ O H R
Lower limit absolute value	Measuring range lower limit value	inside measuring range	△ O L R
Higher limit deviation	2000	-19999 to 30000	△ O H d
Lower limit deviation	-1999	-19999 to 30000	△ O L d
Inside higer/ Lower limit deviation	30000	0 to 30000	△ O ̄ d
Outside higer/ Lower limit deviation	30000	0 to 30000	△ O □ d
Output 1 higher limit value	100.0	0.0 to 100.0	△ O 1 H
Output 1 lower limit value	0.0	0.0 to 100.0	△ O 1 L
Output 2 higher limit value	100.0	0.0 to 100.0	△ O 2 H
Output 2 lower limit value	0.0	0.0 to 100.0	△ O 2 L

*Display character columns △: E, d, O: 1-6 change with the event No.

Note

- If alarm types other than those stated above are assigned to event type and DO type, it will not be displayed.

8-4 Pattern Information Copy

Specify the pattern No. of the copy source.

2-21

COPY
OFF

Setting range: oFF, 1-9
Initial value: oFF

Pattern information (including step information) of the specified pattern No. is reproduced in the presently changed pattern information.



9 Step Setting

9-1 Setting Related to Step

Perform setting with every step.

Below, the setting operation is explained for start pattern 1 and step 1 as an example.

(1) Step SV Value

Sets SV value of Step 1.

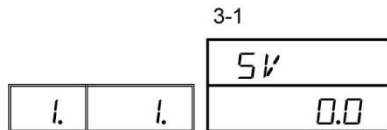

Setting range: within SV Limiter setting range

Initial value: 0.0

Note

- Regarding the SV monitor during program execution on the basic screen
In slope step, SV value (monitor) changes together with step time.
SV value (monitor) of step "n" starts with step "n-1" SV value, and terminates with Step "n."

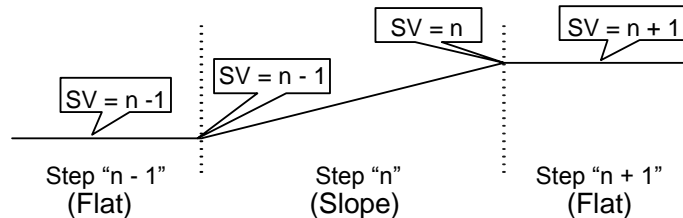

(2) Step Time

Sets Step 1 time.

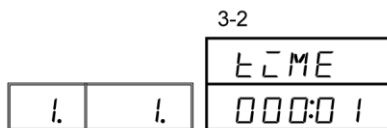

Setting range: 000:00-300:00

Initial value: 000:01

* If time setting mode is on BCD, the setting range is 000:00-099:59.

Note

- In the old models (FP23, FP93, etc.), step time is up to a maximum count of 99:59, but in the SRP30 Series, that function has been enhanced to a maximum count of 300:00.

In the old model, when this parameter is processed by communication, if in 16 bit data length BCD, the maximum value expressed is 99:59, but in the SRP30 Series, a value exceeding 99:59 is assumed so BCD cannot be used.

For this reason, in the SRP30 Series, step time processed by communication is in HEX value. In HEX, communication compatibility with old models is lost but it has the merit of being able to process values above 99:59. On the other hand, if compatibility is a priority, use of a BCD similar to the old one is also possible, but the maximum value is limited to 99:59 as stated earlier. One can select a setting between 2 types, HEX mode and BCD mode, through time setting mode setting. Also, when changing the time setting mode from HEX to BCD, step time set to 100:00 and above is initialized at 99:59. For details of the time setting mode, please refer to "15-3 (12) Time Setting Mode."



9 Step Setting

(3) Step PID No.

Sets PID No. when executing Step 1.

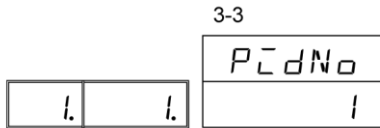

Setting range: 0-9

Initial value: 0

If set to PID = 0, it references previous execution step PID No.

If Start Step is set at PID = 0, PID No. 1 is executed at program start.

9-2 Time Signal

Time signal is 8 points for every 1 step.

If you use time signal as external output, you must first assign TS1-8 to EV1-4/DO1-6 on EV Setting and DO/DI Setting Screen Group.

Please note that time signal may not operate depending on setting content.

During HLD, time signal time also stops. Also, when ADV is operating, time signal time is also shortened.

Valid Conditions for Time Signal (TS)

It is possible to assign invalid conditions, but it will not operate.

(1) If it does not operate

① ON time is OFF

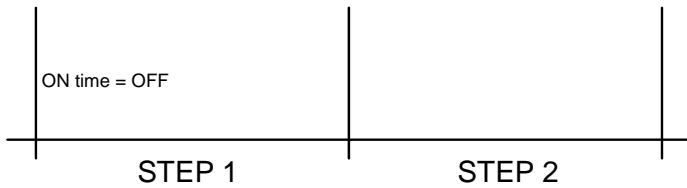

② If ON time exceeds step time

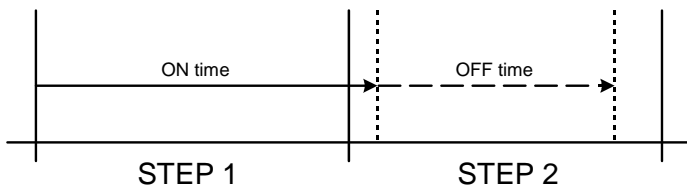



9 Step Setting

(2) Terminating through step termination

① If OFF time is OFF.



② If OFF time exceeds step time.

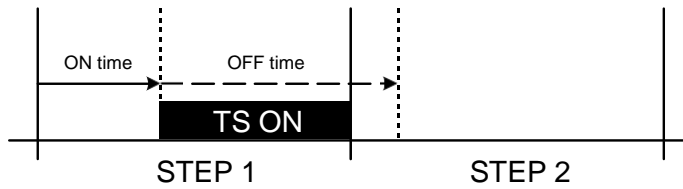

③ Regular action

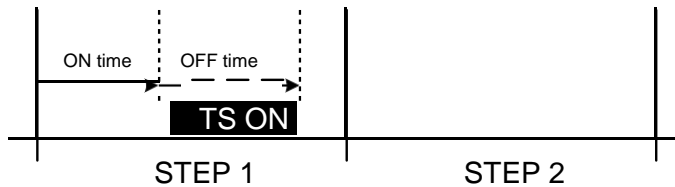

④ One-shot output action

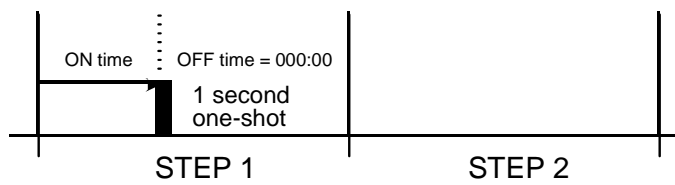

⑤ Output that extends over multiple steps



* Setting step ON time, OFF time between time intervals
By setting ON time to 000:00 and
OFF time to OFF,
one is able to continue time signal output.

<Other setting matters>

- (1) During HLD and guarantee soak, time signal time also stops.
- (2) If ON step and ON time are valid and OFF step assignment is OFF, setting time signal ON also sets pattern termination ON.
- (3) If OFF step or execution OFF time exceeds End Step time, time signal output turns OFF on pattern End Step termination. However, if ON time at the next pattern is 000:00, it turns ON.
- (4) If one changes time signal while on HLD during program execution, it will be reflected after HLD release.



9 Step Setting

(1) Time Signal ON Time

Sets the time between the start of the step that gives the time signal 1 (TS1) signal and the giving of the signal itself.

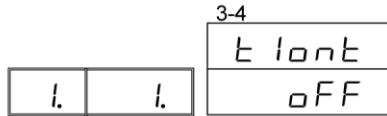

Setting range: oFF, 000:00–300:00

Initial value: oFF

* If time setting mode is on BCD, setting range is OFF and from 000:00 to 099:59.

Note

If time signal 1 is not assigned to EV and DO, it will not be displayed.

(2) Time Signal OFF Time

Sets the time from turning ON time signal 1 (TS1) signal to stopping the signal.

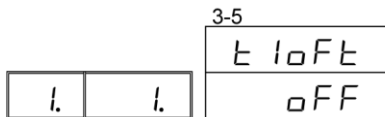

Setting range: oFF, 000:00–300:00

Initial value: oFF

* If time setting mode is on BCD, setting range is OFF and from 000:00 to 099:59.

* Changing No. of pattern used initializes the setting value of step SV, step time, step PID No., and time signal.

Note

- If time signal ON time is OFF, it is not displayed.
- If time setting mode, like step time, is HEX, it can be set up to 300:00 but loses its compatibility with old models. In BCD mode, Compatibility can be maintained but the maximum value is limited to 99:59.
- In changing setting mode from HEX to BCD, time signal ON/OFF time set above 100:00 will be set back to 99:59. For details on time setting mode, please refer to “15-3 (12) Time Setting Mode.”



10 Setting FIX

10-1 Switching FIX Mode

FIX Mode (fixed value control) can be set.

		4-1
		F _{IX}
		oFF

Setting range: oFF, oN

Initial value: oFF

oFF: turns to program mode

oN: turns to FIX mode (fixed value control)

Note

- If FIX is assigned to DI, only monitor is possible.

10-2 Setting FIX SV No.

Sets Execution SV No. during fixed value control (FIX Mode: ON).

No. assigned to FIX SV No. and PID No. are interlocked.

		4-2
		F _{SV} No
		No 1

Setting range: No. 1–No. 9, REM

Initial value: No. 1

Note

- If REM is assigned to DI, set SV No. and REM are switched.
- If FSV No. is assigned to DI, change through key is not allowed.
- If there is no remote option, 1 to 9 is switched.



10 Setting FIX

10-3 Setting FIX SV Value

Sets SV value durinfixed value control (FIX Mode: ON).

<input type="text"/>	<input type="text"/>	4-3 F_SV1 0.0	Setting range: Within SV limiter Initial value: 0.0
<input type="text"/>	<input type="text"/>	4-4 F_SV2 0.0	
<input type="text"/>	<input type="text"/>	4-5 F_SV3 0.0	
<input type="text"/>	<input type="text"/>	4-6 F_SV4 0.0	
<input type="text"/>	<input type="text"/>	4-7 F_SV5 0.0	
<input type="text"/>	<input type="text"/>	4-8 F_SV6 0.0	
<input type="text"/>	<input type="text"/>	4-9 F_SV7 0.0	
<input type="text"/>	<input type="text"/>	4-10 F_SV8 0.0	
<input type="text"/>	<input type="text"/>	4-11 F_SV9 0.0	



10-4 FIX EV/DO Action Point

Sets action point of every EV and DO in FIX mode.

4-12

		E 1Hd
		2000.0

4-13

		E 2Ld
		-199.9

4-14

		E 3Hd
		30000.0

4-15

		E 4Hd
		30000.0

4-16

		do 1Hd
		30000.0

4-17

		do 2Hd
		30000.0

4-18

		do 3Hd
		30000.0

4-19

		do 4Hd
		30000.0

4-20

		do 5Hd
		30000.0

4-21

		do 6Hd
		30000.0

Alam type	Initial value	Setting range	Display character column
Higher limit absolute value	Measuring range higher limit value	inside measuring range	△OHR
Lower limit absolute value	Measuring range lower limit value	inside measuring range	△OLR
Higher limit deviation	2000	-19999 to 30000	△OHd
Lower limit deviation	-1999	-19999 to 30000	△OLd
Inside higer/ Lower limit deviation	30000	0 to 30000	△O \bar{L} d
Outside higer/ Lower limit deviation	30000	0 to 30000	△Ood
Output 1 higher limit value	1000	0.0 to 1000	△OIH
Output 1 lower limit value	0.0	0.0 to 1000	△OIL
Output 2 higher limit value	1000	0.0 to 1000	△O2H
Output 2 lower limit value	0.0	0.0 to 1000	△O2L

*Display character columns △: E, d, O: 1-6 change with the event No.

Note

- If alarm types other than those stated above are assigned to event type and DO type, it will no be displayed.



11 Setting Remote (REM)

11 Setting Remote (REM)

11-1 Remote Bias

Sets Remote Bias value.

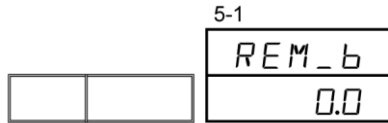

Setting range: -10000–10000 digit
Initial value: 0 digit

Remote Bias is settable until ± 10000 digit, but accuracy guarantee is within 0 to 100% range of the remote signal input.

Please make sure that the value you actually use does not exceed this accuracy range.

11-2 Remote Filter

Sets Remote Filter.

This is a time constant of primary delay operation aimed at effect reduction and stabilization in case it is included in the remote input signal.

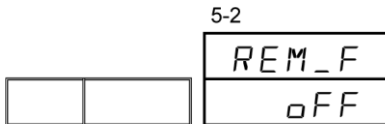

Setting range: oFF, 1–300 sec.
Initial value: oFF

11-3 Remote Ratio

Sets ratio of Remote SV.



Setting range: 0.001–30.000 times
Initial value: 1.000 times

■ If ratio is set in Remote (Bias = 0)

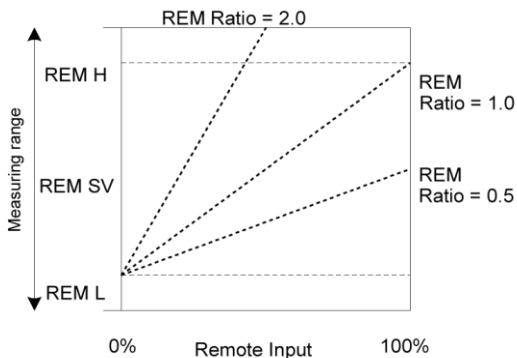

REM H: Remote higher limit
REM L: Remote lower limit

■ If ratio and bias are set in Remote

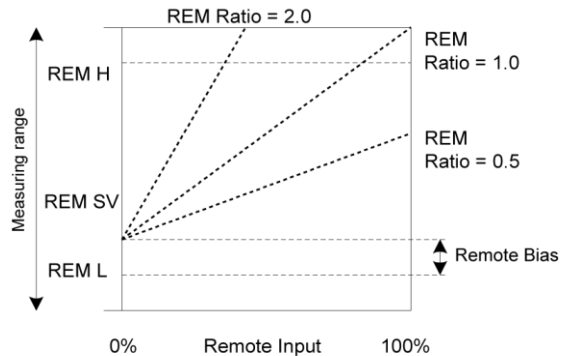

Remote SV value is created by scaling remote input signal, multiplying remote ratio to the result, and, if necessary, adding bias.



11 Setting Remote (REM)

Note

- If Remote Ratio is made extremely big, the range that can be used as remote signal input becomes extremely narrow, and if Remote Ratio is made extremely small, the range of remote SV becomes extremely narrow.
If the bias placed is big, the usable range becomes even narrower. If you use this function, make sure to consider these points sufficiently.
- The remote SV value resulting from remote SV creation operation is subject to limitation by the SV limit value.
- Remote SV value is computed using the following formula.

$$\text{Remote SV value} = X \times A + B$$

X: Remote input signal

A: Remote Ratio

B: Remote Bias

11-4 Remote PID

Sets Remote PID corresponding to Remote SV.

Select from PID No. 1 to PID No. 9.

However, if zone PID function is used, the setting here becomes invalid.

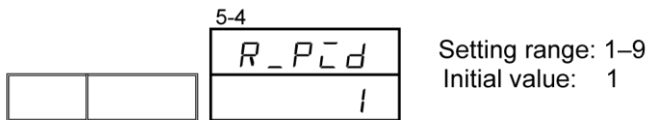

11-5 Remote Scaling

Sets the range used as SV in Remote Input Signal.

Perform scaling within the measuring range.

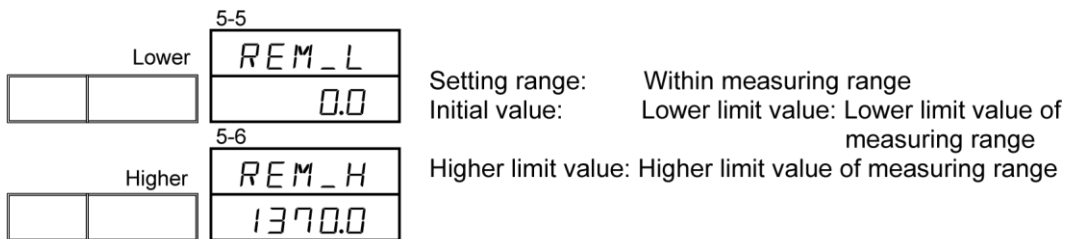

(1) RM_L < RM_H

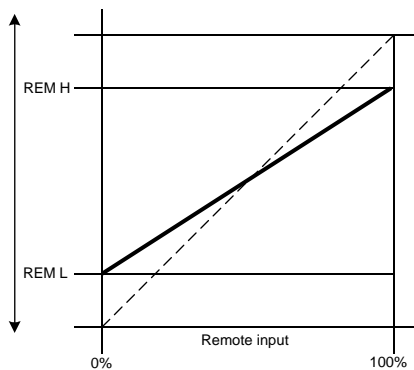

(2) RM_L > RM_H

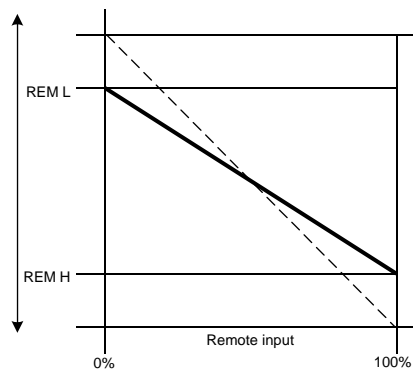

Note

- Inverse scaling is possible.



11 Setting Remote (REM)

11-6 Remote Square Root Extraction

Sets Remote Square Root Extraction.

This is a function that linearizes a signal with square-law characteristics.

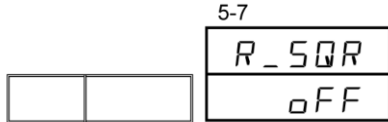

Setting range: oFF, oN

Initial value: oFF

11-7 Remote Low Cut

Setting this is possible if Square Root Extraction is valid.

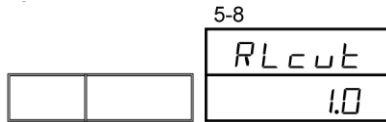

Setting range: 0.0–5.0%

Initial value: 1.0%

When input signal is near 0, a small change in input variation causes a huge fluctuation in the result. If lower than set value, through the function that makes remote input signal 0, unstable operation is prevented in cases in which noise is carried in the input signal.

11-8 Remote Tracking

This is a function to write the remote SV value in SV value of set SV No.

This is operated while causing the SV value to change through analog remote signal, and, at some point of the remote SV value, switch to fixed value operation is enabled.

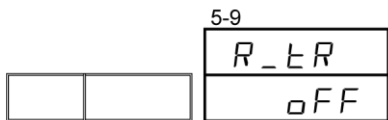

Setting range: oFF, oN

Initial value: oFF

■ Remote Tracking: Action during ON

If remote SV is switched to local SV, remote SV value is written in the SV value of the switched SV No.

■ Remote Tracking: Action during OFF

Remote Tracking does not function.



12 Setting PID

12-1 Proportional Band (P)

Proportional band refers to the range in which control output size is allowed to change the controller input in proportion to the difference (deviation) between measured value (PV) and set value (SV). Here, the rate (%) at which control output is allowed to change with respect to the measuring range is set.

If the proportional band is wide, change in control output with respect to the deviation becomes small, while the offset (steady-state deviation) becomes large.

If the proportional band is narrow, change in control output becomes big, while the offset becomes small. Also, if the proportional band becomes too narrow, hunting (oscillation) occurs, and the action becomes similar to ON-OFF control.

Setting P to OFF makes it ON-OFF control. Also, auto-tuning cannot be executed.

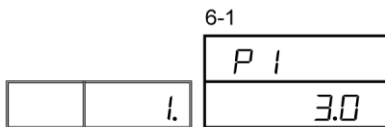

Setting range: oFF, 0.1–999.9%
Initial value: 3.0%

12-2 Hysteresis (DF)

This is an item to set hysteresis (DF) of ON-OFF control action if set P = OFF.

Setting hysteresis narrowly makes it prone to output chattering.

Setting hysteresis widely makes control action stable by avoiding chattering, but the ON-OFF cycling becomes big.

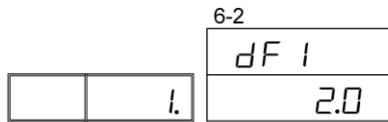

Setting range: 1–10000 digit
Initial value: 2.0 digit

Note

- Not displayed unless output 1P is OFF.

12-3 Integral Time (I)

Integral action is a function that corrects offset (steady-state deviation) caused by proportional action,

If the integral time is long, offset corrective action is weak and correction takes time.

The shorter the integral time, the stronger the corrective action, and if it becomes too short, hunting (oscillation) occurs and becomes similar to ON-OFF control action.

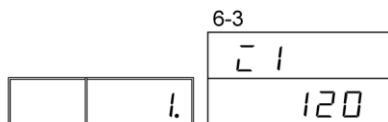

Setting range: oFF, 1–6000 sec.
Initial value: 120 sec.

If auto-tuning is executed while I = OFF, it computes Manual Reset (MR) value and creates an automatic setting.

Note

- Not displayed if Output 1P is OFF.



12 Setting PID

12-4 Derivative Time (D)

Derivative action is a function that predicts change in control output, and minimizes the effect of external disturbance while it suppresses overshoot (going to extremes) caused by integration, thereby improving control stability.

The shorter the derivative time, the weaker the action, and conversely the longer the derivative time, the stronger the action. If it is too long, hunting (oscillation) occurs, and creates a situation similar to ON-OFF control action.

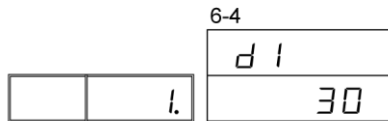

Setting range: OFF, 1–3600 Sec.
Initial value: 30 Sec.

If auto-tuning is executed while D = OFF, only PI (proportion, integration) value is computed.

Note

- Not displayed if Output 1P is OFF.

12-5 Manual Reset (MR)

This is a function that manually corrects offset which occurs when I (integral time) is set to OFF, and control action is performed in P or P + D.

If value is set on the + side, control result moves in the + direction, and if value is set on the - side, it moves in the - direction, the movement volume being proportional to the size of the numeric value.

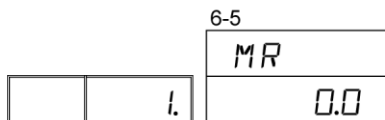

Setting range: -50.0–50.0%
Initial value: 0.0% (during 1 output)
-50.0% (during 2 output)

Note

- Not displayed if Output 1P is OFF.

■ MR Automatic Setting

If auto-tuning is executed, Manual Reset (MR) value is computed and automatic setting is made.

During PID control, it is used as target load factor of PID initial operation.

For this reason, if one wishes to reduce overshoot when power supply is ON or RESET → RUN, set MR value lower and reduce this target load factor.

If one performs Auto-tuning using this instrument's PID control, even in the absence of I action, load factor is calculated to reduce offset, and the value equivalent to Manual Reset is automatically set.



12-6 Target Value Function (SF)

Target Value Function has a functional feature that determines the strength of overshoot prevention function during expert PID operation.

Target Value Function is valid only if there is integral action (PI and PID actions).

		6-6	SF 1	Setting range: oFF, 0.00–1.00 Initial value: 0.40
	I.		0.40	

SF = oFF: Normally PID operation is performed and overshoot correction function does not work.

SF → small: Overshoot correction function works weakly.

SF → big: Overshoot correction function works strongly.

Note

- Not displayed if Output P is OFF.

■ Note: PID Action Through Target Value Function (SF) Setting

During slope step time, PID and PD actions can be switched automatically depending on SF value. By controlling slope step through PD action, flat step overshoot can be reduced.

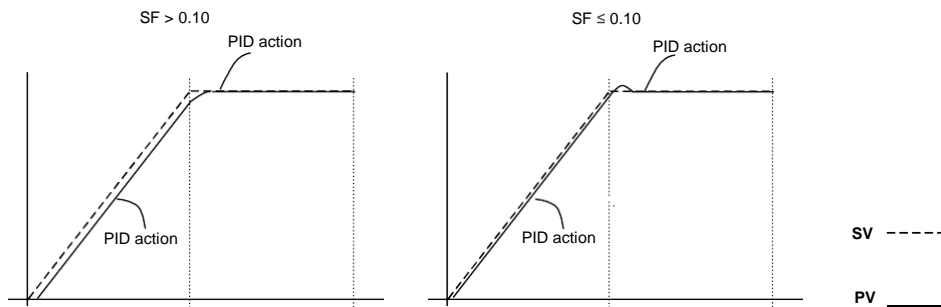

12-7 Output Limit Value (OUT1L–OUT2H)

This is the screen for setting the lower limit value and higher limit value of control output value matched to the PID No.

In normal control operation, the initial value is used as is, but this value is used in control operation requiring higher accuracy.

For heating, if the upper side overshoots and recovery seems slow, set the higher limit value lower. In a controlled object where temperature increase is slow, and if one lowers output, temperature drops immediately, set lower limit value higher.

		6-7	Lower Limit Value	01.L	Setting range: Lower limit value: 0.0–99.9% Higher limit value: 0.1–100.0% (However, lower limit value < higher limit value)
	I.			0.0	
		6-8	Higher Limit Value	01.H	Initial value: Lower limit value: 0.0% Higher limit value: 100.0%
	I.			100.0	

Note

- If P is set to OFF, and operation is ON-OFF control, output limit becomes invalid during contact output and SSR drive voltage output.
- Output limit is invalid during Auto-tuning.

The same goes for output 2 setting.



12 Setting PID

12-8 Dead Band (DB)

This setting is only for the 2-output specification.

The action field of output 2 takes into consideration characteristics of the controlled object characteristics and energy conservation.

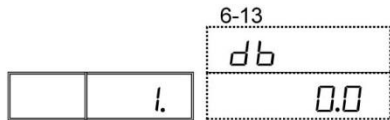

Setting range: -19999–30000 digit
Initial value: 0.0 digit

The relationship between output action and DB takes on a pattern as illustrated in the figure below.

RA: Reverse Action

DA: Direct Action

■ Control Output 1: RA, Control Output 2: DA (RA+DA)

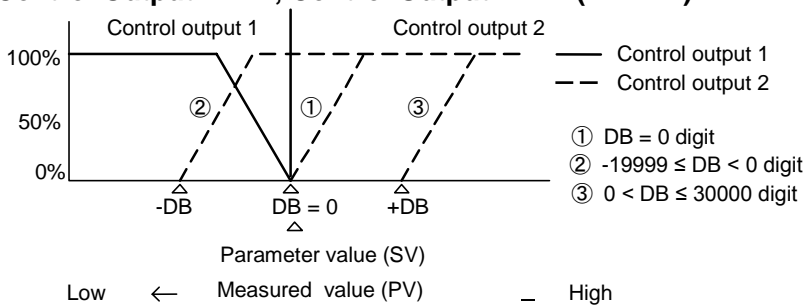

■ Control Output 1: RA, Control Output 2: RA (RA + RA)

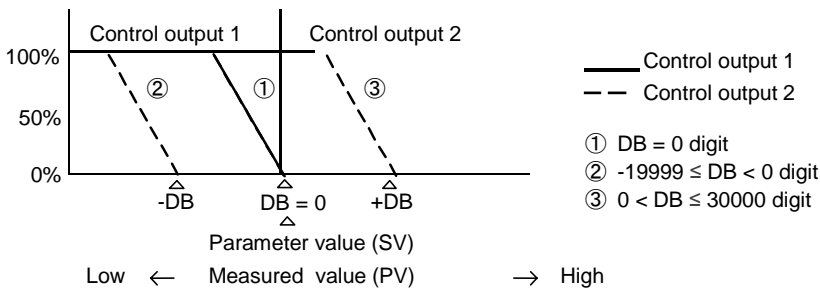

■ Control Output 1: DA, Control Output 2: RA (DA + RA)

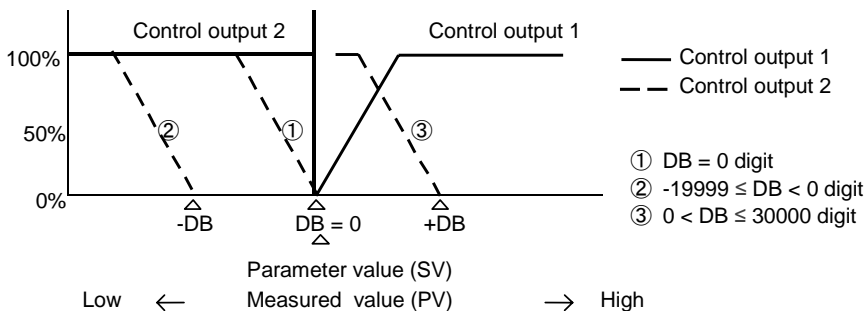

■ Control Output 1: DA, Control Output 2: DA (DA + DA)

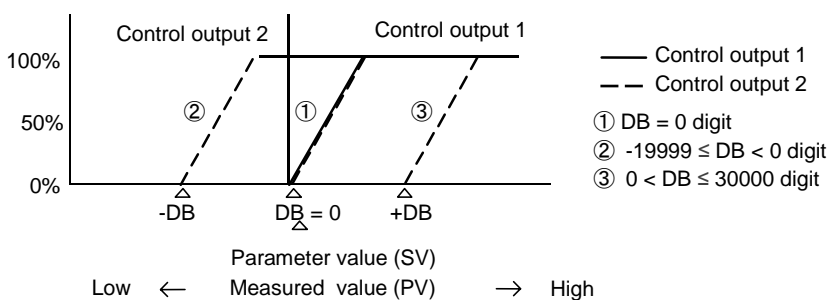



12-9 Setting Zone PID

This is a function that enables one to set multiple zones within the measuring range and use a different PID value for every zone by switching.

Using this function enables one to set an optimal PID value for every temperature range (zone) and obtain favorable controllability with a wide temperature range.

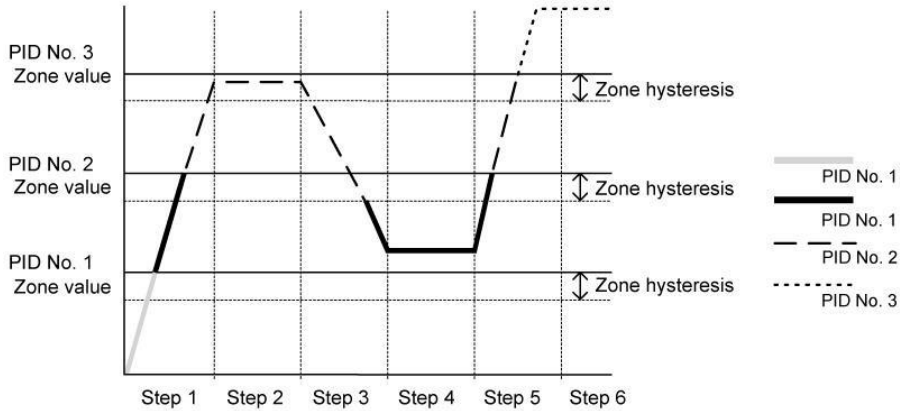

Note

- Zone 1 = PID No. 1, Zone 9 = PID No. 9
- If one sets the same value in multiple zone values, the lower PID No. is executed.
- If zone value and zone hysteresis are changed while SV value is within zone hysteresis, the PID No. executed will not be changed while still in zone hysteresis.
- In order to use Zone PID function, one has to set not only the zone but also the zone hysteresis.

(1) Selection of Zone PID

One selects whether to use zone PID or not.

During use, one has to further select whether to set the zone using SV or PV.



oFF: Does not use zone PID function.

SV: Uses zone PID function of SV.

PV: Uses zone PID function of PV.



12 Setting PID

(2) PID Zone Value

One sets the zone value (temperature range) used in Zone PID function.

6-2

		Z 15P
	Z.	0.0

Setting range: Within measuring range
Initial value: 0 digit

6-3

		Z 25P
	Z.	0.0

6-4

		Z 35P
	Z.	0.0

6-5

		Z 45P
	Z.	0.0

6-6

		Z 55P
	Z.	0.0

6-7

		Z 65P
	Z.	0.0

6-8

		Z 75P
	Z.	0.0

6-9

		Z 85P
	Z.	0.0

6-10

		Z 95P
	Z.	0.0

(3) Zone Hysteresis

One can set hysteresis for the zone set value.
This hysteresis is valid for all zone set values.

6-11

		Z HYS
	Z.	2.0

Setting range: 0-10000 digit
Initial value: 20 digit



13 Setting Event (EV)

13-1 Event Action

Sets event action mode. Please take note that when this setting is changed, action setting point and action hysteresis parameter are initialized.

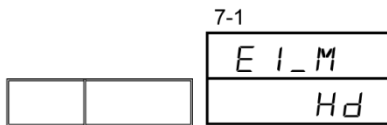

Setting range: Refer to the Event (EV)/DO Assignable Types below.

Initial value: EV1: Hd

EV2: Ld

EV3: Run

EV4: non

■ Event (EV)/DO Assignable Types

Type	Display	Action	OP
non	<i>non</i>	No action	
Hd	<i>Hd</i>	Higher limit deviation alarm	
Ld	<i>Ld</i>	Lower limit deviation alarm	
od	<i>od</i>	Outside higher/lower limit deviation alarm	
id	<i>id</i>	Within higher/lower deviation alarm	
HA	<i>HA</i>	Higher limit absolute value alarm	
LA	<i>LA</i>	Lower limit absolute value alarm	
out1H	<i>out 1H</i>	Output 1 upper limit absolute value alarm	
out1L	<i>out 1L</i>	Output 1 lower limit absolute value alarm	
out2H	<i>out 2H</i>	Output 2 upper limit absolute value alarm	out2
out2L	<i>out 2L</i>	Output 2 lower limit absolute value alarm	out2
So	<i>So</i>	Scaleover	
PV_So	<i>PV_So</i>	PV scaleover	
RM_So	<i>RM_So</i>	Remote scaleover	REM
REM	<i>REM</i>	Remote SV	REM
FiX	<i>FiX</i>	FIX Mode	
At	<i>At</i>	Auto-tuning	
Run	<i>Run</i>	RUN signal (EXE signal)	
HLd	<i>HLd</i>	Hold signal	
GuA	<i>GuA</i>	Guarantee soak signal	
StPS	<i>StPS</i>	Step signal	
PEnd	<i>PEnd</i>	Pattern end signal	
EndS	<i>EndS</i>	Program end signal	
uP	<i>uP</i>	Up slope signal	
doWn	<i>doWn</i>	Down slope signal	



13 Setting Event (EV)

tS1-tS8	$tS1 \sim tS8$	Time signal 1-8	
Ct1bA	$Ct1bA$	Heater 1 break alarm (CT1)	HB
Ct1LA	$Ct1LA$	Heater 1 loop alarm (CT1)	HB
Ct2bA	$Ct2bA$	Heater 2 break alarm (CT2)	HB
Ct2LA	$Ct2LA$	Heater 2 loop alarm (CT2)	HB
Ct_bA	Ct_bA	Heater break alarm (CT1, CT2 OR (logical disjunction))	HB
Ct_LA	Ct_LA	Heater loop alarm (CT1, CT2 OR (logical disjunction))	HB

Alarm Action

△: SV value

▲: Alarm action point setting value

(1) No alarm action (no)

(2) Higher limit deviation alarm (Hd)

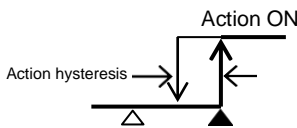

(3) Lower limit deviation alarm (Ld)

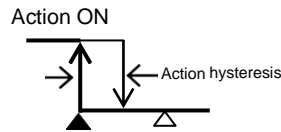

(4) Outside higher/lower limit deviation alarm (Ld)

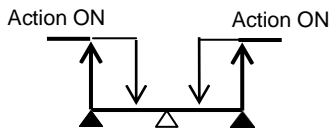

(5) Within upper/lower limit deviation alarm (od)

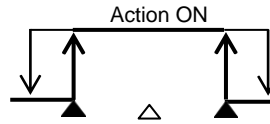

(6) Higher limit absolute value alarm ($HA, out1H, out2H$)

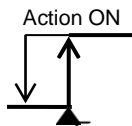

(7) Lower limit absolute value alarm ($LA, out1L, out2L$)

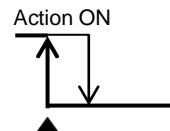

(8) Scaleover ($So, PVSo, RMSo$)

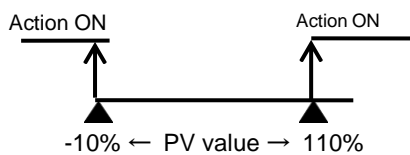

So: If either PV or remote goes scaleover, output is switched ON.

PVSo: If PV goes scaleover, output is switched ON.

RMSo: If remote goes scaleover, output is switched ON.

* ON/OFF in the figure shows action status.

Event output follows setting of output characteristics.

(9) Remote SV (REM)

When remote SV is in execution, output is switched ON.

(10) FIX Mode (FIX)

When FIX Mode is in execution, output is switched ON.



13 Setting Event (EV)

- (11) Auto-tuning (*At*)
When auto-tuning is in execution, output is switched ON.
- (12) RUN status (*Run*)
When run status is in execution, output is switched ON.
- (13) Hold signal (*HLd*)
When program is in execution, and when set to hold ON, output is switched ON.
- (14) Guarantee soak signal (*GUR*)
When program is in execution, output continues while guarantee status arises.
- (15) Step signal (*STPS*)
When program is in execution, every time step ends, output is ON for 1 sec.
- (16) Pattern end signal (*PEnd*)
When program is in execution, every time pattern ends, output is ON for 1 sec.
If No. of pattern executions is set to 2 or more, this is switched ON with every pattern execution.
- (17) Program end signal (*EndS*)
Time and output specified at the end of the program (including when there is status change RUN→RESET/PROG→FIX) are switched ON.
- (18) Up slope signal (*UP*)
When program is in execution, during upward slope step, output is switched ON.
- (19) Down slope signal (*down*)
When program is in execution, during downward slope step, output is switched ON.
- (20) Time signal 1-8 (*TS 1-8*)
When program is in execution, if the relevant time signal is valid, output is switched ON.
- (21) Heater break alarm (*CT1bA, CT2bA, CT_bA*)
During heater break alarm, output is switched ON. (Output is by CT1, CT2 as well as CT1, CT2 disjunction (OR).)
Disjunction (OR): If any of the two inputs is switched ON, EV and DO are switched ON.
- (22) Heater loop alarm (*CT1LA, CT2LA, CT_LA*)
During heater loop alarm, output is switched ON. (Output is by CT1, CT2 as well as CT1, CT2 disjunction (OR).)
Disjunction (OR): If any of the two inputs is switched ON, EV and DO are switched ON.

13-2 Hysteresis

Sets hysteresis of ON Action and OFF Action. In avoiding chattering, stable action is achieved.

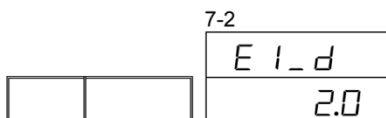

Setting range: 1-9999 digit
Initial value: 20 digit



13 Setting Event (EV)

13-3 Standby Action

Standby action is a function in which event is not output even if PV value is within the event action range when power is applied, when switching RESET → RUN or when SV is changed, and EV/DO is output when PV value goes out of the event action range and it re-enters the event action range. For selection, take into consideration standby action and event action during scaleover.



oFF: No standby action

1: Standby when power is applied or when switched RESET→RUN

2: Standby when power is applied, when switched RESET→RUN, or when SV value is changed

3: Control mode (No standby action)

Control mode: Scaleover input abnormality action OFF

13-4 Output Characteristics

Selects Output Characteristics.

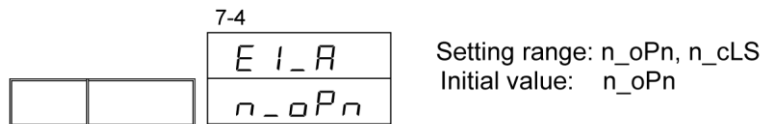

n_oPn (Normal open): When event action is ON, output contact closes.

n_cLs (Normal close): When event action is ON, output contact opens.



13-5 Delay Time

Delay Time is a function that outputs event after set time from the occurrence of event factor. If output factor lapses within the Delay Time, event will not be output.

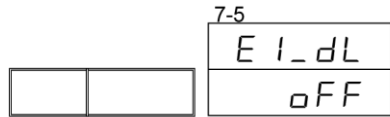

Setting range: oFF, 1–9999 sec.
Initial value: oFF

13-6 Latching Selection

Selects latching.

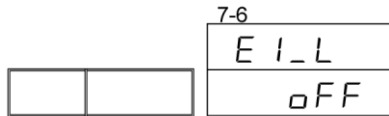

Setting range: oFF, oN
Initial value: oFF

■ No Latching Action

Performs normal alarm action.

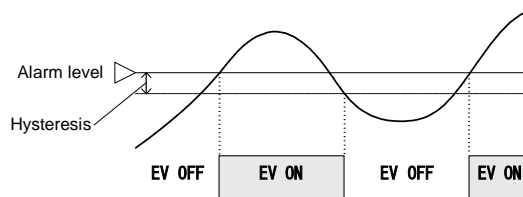

■ With Latching Action

Performs latching action. Once alarm is set to ON, alarm continues to set off until latching is released.

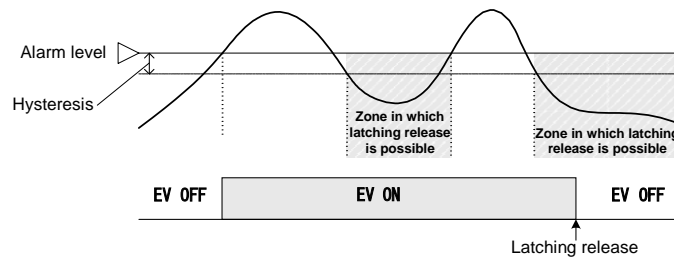

* Latching action is released once event type is changed.

Same goes for setting of EV2–EV4.



14 DO/DI SETTING

14 DO/DI SETTING

14-1 Setting DO

(1) DO Action

Sets DO Action mode. Please take note that if setting is changed, action setting point and action hysteresis parameter are initialized.

		8-1
		do I_M
		non

Setting range: For details refer to the Event (EV)/DO Assignable Types.
Initial value: Non

(2) Hysteresis

Sets action hysteresis of ON action and OFF action. In avoiding chattering, stable action is achieved.

		8-2
		do I_d
		2.0

Setting range: 1–9999 digit
Initial value: 20 digit

(3) Selection of Standby Action

Standby action is a function in which DO is not output even if PV value is within the DO action range when a power is applied, when switching RESET → RUN, or when SV is changed, and DO is output when PV value goes out of the DO action range and it re-enters the event action range.

For selection take into consideration DO action during standby and scaleover.

		8-3
		do I_̄
		oFF

Setting range: oFF, 1, 2, 3
Initial value: oFF

oFF: No standby action

1: Standby when power is applied or when switched RESET→RUN

2: Standby when power is applied, when switched RESET→RUN, or when SV value is changed

3: Control mode (No standby action)

Control mode: Scaleover input abnormality action OFF

(4) Output Characteristics

Selects Output Characteristics.

		8-4
		do I_R
		n_oPn

Setting range: n_oPn, n_cLS
Initial value: n_oPn

n_oPn (Normal open): When DO action is ON, transistor switches output ON.

n_cLS (Normal close): When DO action is ON, transistor switches output OFF.



(5) Delay Time

Delay Time is a function that outputs DO after the set time from occurrence of event factor. If output factor lapses within the Delay Time, the event will not be output.

		8-5
		do l d L
		o F F

Setting range: oFF, 1–9999 sec.
Initial value: oFF

(6) Latching Selection

Selects latching action.

		8-6
		do l _ L
		o F F

Setting range: oFF, oN
Initial value: oFF

Same goes for setting DO2–DO6.

14-2 DI Setting

DI is a digital input signal for performing external control through non-voltage contact signal or open collector signal from outside.

One can select the function one wants to execute and assign that to DI1–DI7.

(1) DI Assignment Function

This is a function assignment to DI.

		8-37
		d c̄ 1 c
		n o n

		8-38
		d c̄ 2 c
		n o n

		8-39
		d c̄ 3 c
		n o n

		8-40
		d c̄ 4 c
		n o n

		8-41
		d c̄ 5 c
		n o n

		8-42
		d c̄ 6 c
		n o n

		8-43
		d c̄ 7 c
		n o n

Setting range: Refer to the Input Type Assignment Table on the following page.

Initial value: Non



14 DO/DI SETTING

■ Input Type Assignment Table

Type	Display	Action	Non-Action condition	OP condition
non	non	No assignment		
Run1	Run1	Switch Run/Reset (Level)	none	
Run2	Run2	Switch Run/Reset (Edge)	none	
RSt	RSt	Program forced reset (Level)	none	
HLd	HLd	Hold processing (Level)	none	
AdV	AdV	Advance processing (Edge)	HLD	
FiX	FiX	FIX Mode (Level)	none	
MAn	MAn	Manual output (Level)	AT	
LrS	LrS	Latching total release (Edge)		
KLock	KLock	Keylock 3 (Level)		
Ptn3	Ptn3	Start pattern No. 3 bit (Level)		DI
FSVNo	FSVNo	SV No. 3 bit (Level)		DI
Act1	Act1	Output 1 output characteristics (Level)		
Act2	Act2	Output 2 output characteristics (Level)		OUT2
REM	REM	Remote SV switch (Level)		REM

* During program execution, if Start Pattern No. is changed through DI, it will not be reflected until it turns to Reset status.

* If the same type is assigned to multiple DI, only the DI with the smallest number will be active. If Run 1 is assigned to DI and PROGRAM is terminated, PROGRAM cannot be executed again unless Run1 (DI) is set to OFF once. When assigning Run1 and RSt to multiple DI, interrupting control by switching RSt input ON while Run1 input is ON will disable resumption of control unless Run1 (DI) and RSt (DI) are switched OFF once.

* Ptn3 (Start Pattern No. 3 bit) and FSVNo. (SV No. 3 bit) are assignable only to DI5 and occupies 3 points from DI5 to DI7. If Ptn3 or FSVNo. is assigned to DI15, DI6 and DI7 will not be displayed.

* If Remote SV is switched to Local SV through DI to which REM (Remote Switch) has been assigned, it will always switch to SV No. 1.

If you wish to switch to optional SV No., set FSV No. (SV No. 3 bit) to DI and specify the SV No. of the switching destination.

* If FIX is assigned to DI, it will switch to Reset status at program end, even if the setting at “15-21 FIX Switching at Program End” is ON.

DI (Terminal No.)	Start Pattern No.							
	0	1	2	3	4	5	6	7
DI5(27)		*		*		*		*
DI6(28)			*	*			*	*
DI7(29)					*	*	*	*

DI (Terminal No.)	SV No.							
	0	1	2	3	4	5	6	7
DI5(27)		*		*		*		*
DI6(28)			*	*			*	*
DI7(29)					*	*	*	*

*: Short between DI and COM (5)

Note

If you select start pattern No. 0, SV No. 0 (while DI Input is OPEN status), it will become pattern No. 1 and SV No. 1.



15 Communication Setting

15-1 Outline

(1) Communication Interface

By option, the SRP30 Series is compatible with two types of communication system, RS-232C/RS-485, and, using the same communication interface, one can perform various data setting and reading from a computer.

RS-232C and RS-485 conform to the data communication standards determined by the American Electronics Industrial Association (EIA). This standard regulates hardware, but does not define data transmission procedure software, and, therefore, even between devices that have an identical interface, transmission is not unrestricted.

For this reason, it is necessary for our customers to have adequate prior understanding of data forwarding specifications and transmission procedures.

If you use RS-485, parallel connection of multiple units of SRP30 is possible.

Presently, among computers, models that support RS-485 interface are few, but by using the "RS-485 converter" that is available in the market, it is possible to use RS-485.

(2) Communication Control and its Specifications

The SRP30 Series supports Shimaden standard protocol as well as MODBUS protocol.

■ Common to all Protocols

Signal Level	EIA RS-232C, RS-485-compliant
Communication system	RS-232C: 3-line half duplex system RS-485: 2-line half duplex multidrop (bus) system
Synchronization system	Start-stop synchronization system
Communication distance	RS-232C: maximum 15 m RS-485: total maximum 500 m (differs according to connection condition)
Communication Rate	2400/4800/9600/19200/38400 bps
Communication Delay Time	1-500 msec. Step 1 msec.
No. of communication units	RS-232C: 1 unit RS-485: possible up to 255 units (depending on connection conditions) * Connection node of 255 units of RS-485 should all be SRP30 Series.

■ Shimaden Standard Protocol

This is communication control specific to Shimaden.

Specifications are as listed below.

• ASCII Code

Data length	7, 8 bit
Parity	Even number, odd number, none
Stop bit	1, 2 bit
Control code	STX_ETX_CR/STX_ETX_CRLF/@_:_CR
Communication BBC	Add/Add_two's cmp/XOR/None



15 Communication Setting

■ MODBUS Protocol

MODBUS Protocol is communication protocol developed for PLC by Modicon Inc.

Its specifications are public, but only the communication protocol is defined in MODBUS protocol, and the SRP30 Series physical layer, such as communication medium, is not specified.

Specifications are as listed below.

• ASCII Mode

Data length	7 bit fix
Parity	Even number, odd number, none
Stop bit	1, 2 bit
Control Code	CRLF
Error Check	LRC Check
Function Code	03H Data read 06H Supports data write

• RTU Mode (Binary Mode)

Data length	8 bit fix
Parity	Even number, odd number, none
Stop bit	1, 2 bit
Control code	none
Error check	CRC
Function code	03H Data read 06H Supports data write

15-2 Connection of Controller and Host Computer

Between the SRP30 Series hybrid controller and host computer, transmission, reception and signal grounding, i.e., three lines, are connected. A connection example is shown below.

For details, refer to the host computer manual.

(1) When using RS-232C Interface

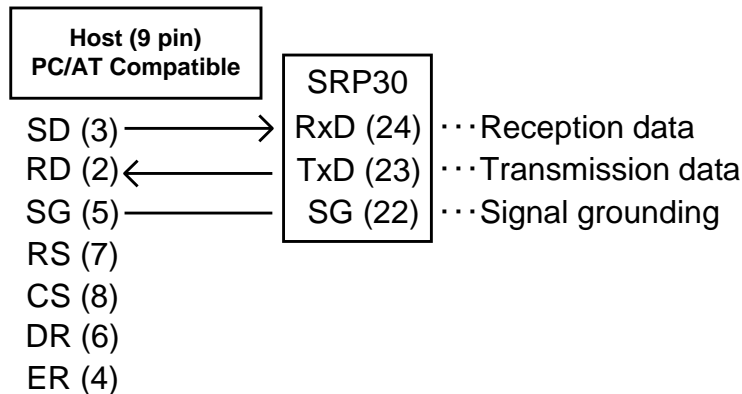

No. in () is the connector pin No.



(2) When using RS-485 Interface

The SRP30 Series input/output logical level is basically as follows.

mark status: -terminal < +terminal space status: -terminal > +terminal

However, the controller's +terminal, -terminal becomes high impedance until right before the start of transmission, and when transmitted, outputs the above level.

Also, if necessary, at the terminal area of a terminal unit (between + and -), install a resistor that is about 1/2 W 120Ω. We do not guarantee the action resulting from the installation of two or more terminal resistors.

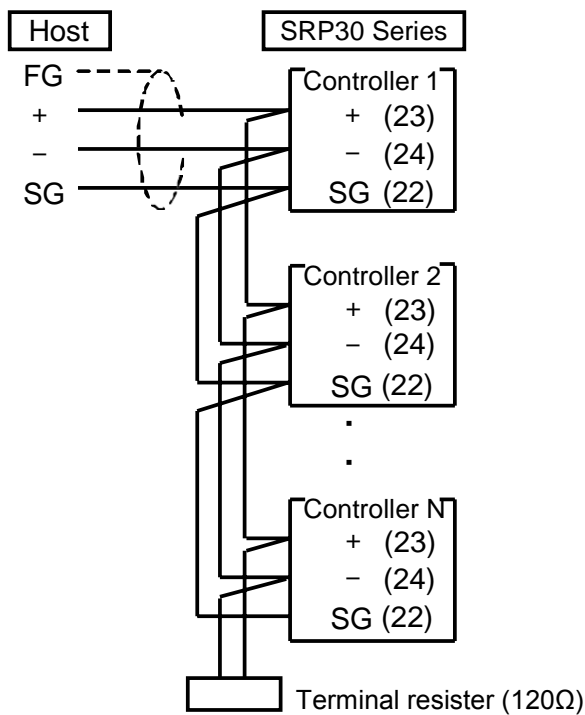

■ 3-state Output Control

Since RS-485 is a multi-drop system, in order to avoid collision of communication signals, when communication is not performed, or during reception, transmission output is controlled so that it is constantly in high impedance.

Right before performing communication, control is changed from high impedance to regular output status, and reverted to high impedance simultaneously with the end of transmission.

The end of transmission does not refer to the time when the last data is written to the transmission output buffer through interrupt request, but to the point when the last data end bit is sent out through the serial controller.

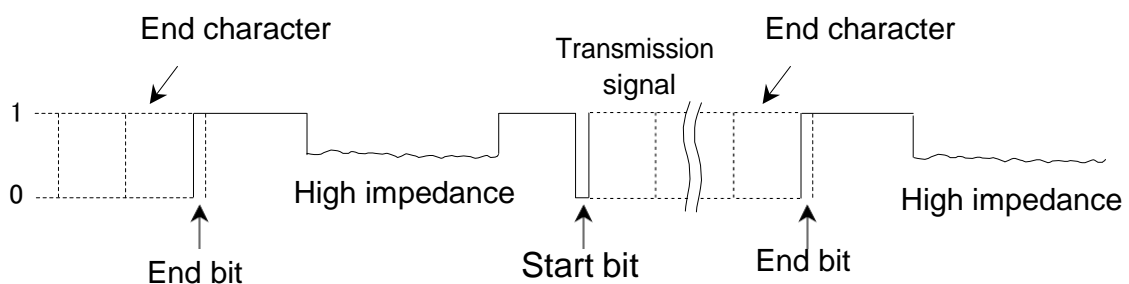



15 Communication Setting

15-3 Communication

For details on communication, please refer below to “15-4 Shimaden Standard Protocol Explanation” and “15-5 MODBUS Protocol Explanation.”

(1) Communication Control

Sets communication control.

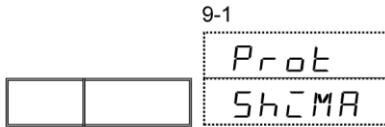

Setting range: ShiMA, ASC, RtU
Initial value: ShiMA

ShiMA: Shimaden Standard Protocol

ASC: MODBUS Protocol (ASCII Mode)

RtU: MODBUS Protocol (RTU Mode)

There are two types in the MODBUS protocol, namely the ASCII mode (ASCII character system) and RTU Mode (binary system), and either one can be selected. However, in the same network, all devices must have the same mode.

ASCII mode converts 1 byte (8 bit) data into 2-character ASCII code and transmits it.

The other RTU Mode transmits 1 byte data as is.

For this reason, RTU mode can be said to have better transmission efficiency than ASCII mode.

(2) Communication Address

Sets the instrument address. (Device address when this instrument is operated as slave.)

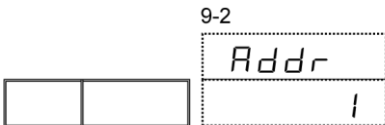

Setting range: 1–255
Initial value: 1

In the case of RS-485, up to 1 to 255 ratio (max) connection is possible.

However, communication is actually done in the ratio of 1 to 1 using a polling system. For this reason, a slave address is set up for each instrument to distinguish them.

Furthermore, it is possible to set an address from 1 to 255 up to 255 units of the instrument at the maximum.

(3) Communication Data

Sets Communication Data.

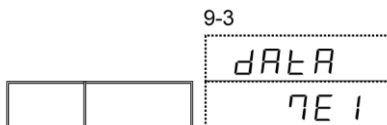

Setting range: 7E1, 7E2, 7n1, 7n2, 7o1, 7o2
8E1, 8E2, 8n1, 8n2, 8o1, 8o2
Initial value: 7E1

7E1: 7: Data length, E: Parity, 1: Stop bit

Data length: 7: 7 bit, 8: 8 bit

Parity: E: EVEN, n: None, o: ODD

Stop bit: 1: 1 bit, 2: 2 bit

The data length of the MODBUS Protocol is 7 bit fix for ASCII mode and 8 bit fix for RTU mode.



(4) Start Character

Sets Start Character.

9-4

		StCr
		StXcr

Setting range: StXcr, StXLF, Att

Initial value: StXcr

StXcr: STX_ETX_CR

StXLF: STX_ETX_CRLF

Att: @:_:CR

(5) Communication BCC Data Operating Method

This is a setting item only for Shimaden standard protocol.

9-5

		bcc
		Add

Setting range: Non, Add, Add2, XoR

Initial value: Add

BCC (Block Check Character) data operating method is selected from the 4 types below.

non: No BCC operation

Add: Add operation

Add2: Add operation + 2 complementary numbers

XoR: XOR (exclusive disjunction) operation is performed.

For details, refer to "15-4 (4) Details of Basic Format Par II."

(6) Communication Rate

Sets communication rate.

9-6

		bps
		9600

Setting range: 2400, 4800, 9600, 19200, 38400 bps

Initial value: 9600 bps



15 Communication Setting

(7) Communication Delay Time

Sets the minimum delay time from reception of communication command to execution of transmission. However, the actual delay time between reception of communication command and transmission is the total time after adding command processing time to the abovementioned delay time.

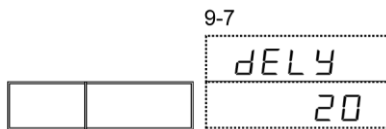

Setting range: 1–500 msec.

Initial value: 20 msec.

Note

- With RS-485, 3-state control can take time depending on the line converter, and signal collision can occur. This can be avoided by increasing the delay time. Caution has to be taken especially when the communication rate is slow (2400 bps).
- The actual delay time between reception of the communication command and transmission is the total time after adding command processing time due to software to the abovementioned delay time. In particular, command processing time of the write command can take more than hundreds of milliseconds.

(8) Communication Memory Mode

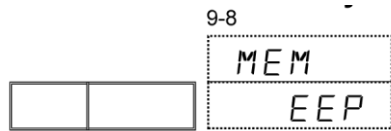

Setting range: EEP, RAM, R_E

Initial value: EEP

For parameter memory, this instrument uses the non-volatile memory EEPROM.

EEPROM has a preset No. of write cycles and frequent SV data overwrite through communication shortens the life span of EEPROM.

To prevent this if one frequently overwrites data through communication, it is possible to set to RAM Mode, then overwrite RAM data only without overwriting EEPROM to lengthen the life span of EEPROM.

Also, with EEPROM, data will be saved even if power is turned OFF, while with RAM, data will not be saved if power is turned OFF.

EEP: Everything will be written to EEPROM.

RAM: Will not be written to EEPROM.

R_E: Will be written to EEPROM except SV, OUT1, and OUT2 data.

(9) Communication Mode Types

Sets Communication Mode Type.

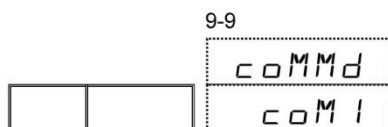

Setting range: coM1, coM2

Initial value: coM1

coM1: Regardless of COM mode, write by communication is possible

coM2: Write by communication is not possible except through COM mode



(10) Master Function

Master function sends the SV value of this instrument to the slave device. It is necessary that the measuring range of Master and Slave be the same.

Sets Master Function to ON and OFF.

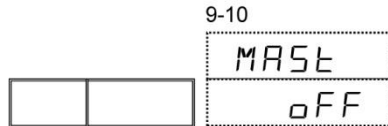

Setting range: oFF, MAsT1, MAsT2

Initial value: oFF

oFF: function none

MAsT1: SV

MAsT2: SV (with RUN/RESET)

(11) Communication Slave Start/End Address

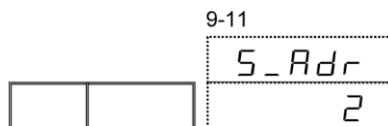

Setting range: Start Address: bcAS, Communication Address + 1–255

End Address: Start Address–Start Address + 29

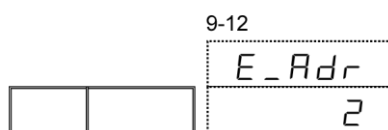

Initial value: 2

If Master Function is MAsT1 or MAsT2, it will be displayed.

Also, if the start slave address is bcAS, communication slave end address will not be displayed.

bcAS : Since it performs broadcast command, slave address is always 0.

(12) Time Setting Mode

Sets time setting data (step time, time signal ON/OFF time) used in communication.

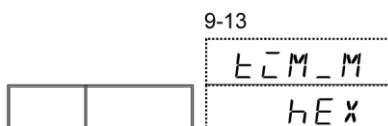

Setting range: HEX, BCD

Initial value: HEX

■ HEX Mode

Time data is converted to a lower unit (min. in HHH:MM, sec. in MMM:SS) and is handled as hexadecimal numbers.

If value is OFF, it is "FFFF."

(Example) Set value Lower Unit Conversion (Decimal number) hexadecimal number
12 hrs. 34 min. → 12 x 60 + 34 = 754 (min.) → 02F2

■ BCD Mode

Time data (lower 4 digits) is considered as a decimal number and handled in BCD. In BCD, since the maximum value that can be expressed as 16 bit is 9999, the valid range is lower than this. Even in setting done through key operation, the setting range of step time and time signal ON/OFF is below 9999.

As an exception, if value is OFF, it is "FFFF."

(Example) Set value BCD
012 hrs. 34 min. → 1234
OFF → FFFF

Note When changing to Time Setting Mode HEX → BCD, time data that exceeds 100:00 is clipped to 99:59.



15 Communication Setting

15-4 Shimaden Standard Protocol Explanation

(1) Communication Procedure

Communication procedure is done by block, and on the host side and slave side, transmission right is transferred block by block. In this event, unless the transmission data from the host is received, it will not be transmitted from the slave side.

This instrument normally operates as a slave but it can also be operated as a master.

If operated as a master, writing execution SV value to the slave side is possible.

MAST1 Action: Performs write of execution SV value

MAST2 Action: Performs RUN/RESET switch and SV value write

(2) Communication Format

Since the SRP30 is compliant to various protocols, one can perform diverse selections in Communication Format (Control code, BCC operation method) and Communication Data Format (data bit length, availability of Parity, Stop Bit length).

However, for convenience and to avoid confusion in communication setting work, we recommend the following format:

	Recommended Format	
Control code	STX_ETX_CR	
BCC operation method	ADD	
Data bit length	7	8
Parity	EVEN	NONE
Stop bit length	1	1

(3) Communication Format Outline

Communication command format transmitted from master and Communication response format transmitted from slave each consists of 3 blocks, namely Basic format part I, Text part, and Basic format part II.

Also, Basic format parts I and II are common in Read command (R), Write command (W), and Communication response. However, for BCC data i (13 and 14), data with every operation result is inserted.

The Text part differs according to command type, data address and communication response.

■ Communication Command Format

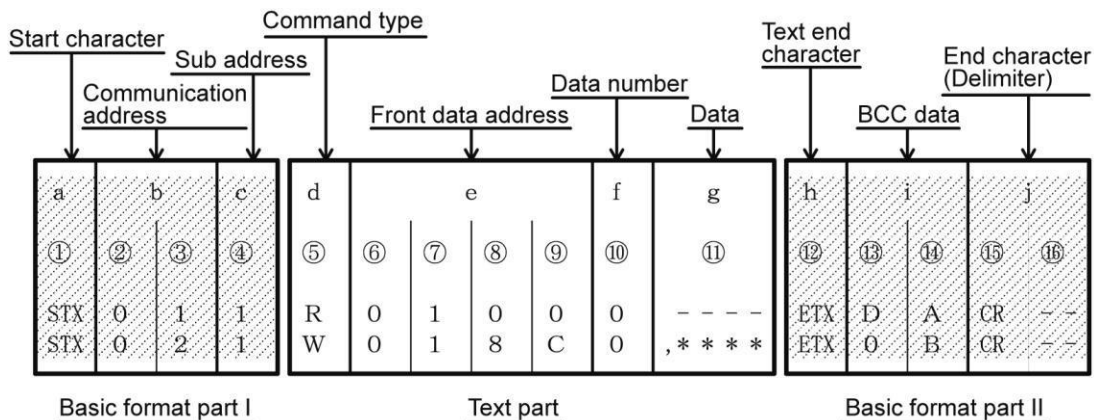



■ Communication Response Format

15 Communication Setting

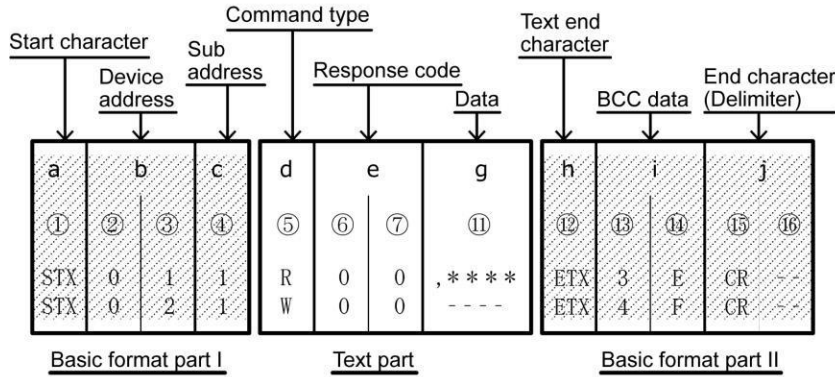

(4) Details of Basic Format Part I

a: Start Character [①: 1 digit/STX (02H) or “@” (40H)]

- Shows that it is the head of the message.
- If Start Character is received, it is decided as the first character of the new message.
- Start Character and Text End Character are selected as a pair.

STX (02H) - - - ETX (03H) selection

“ @ ” (40H) - - - “.” (3AH) selection

b: Communication Address [②, ③: 2 digits]

- Specifies the instrument that performs communication.
- Address is specified within the range 1–254 (decimal number).
- Binary 8 bit data (1: 0000 0001–255: 1111 1110) is divided as higher 4 bit and lower 4 bit and converted to ASCII data.

②: Higher 4 bit converted to ASCII data

③: Lower 4 bit converted to ASCII data

(Example) If address No. is 100 (64), Higher: 36H, Lower: 34H

- Since device address = 0 (30H, 30H) is used during broadcast command, it cannot be used as device address.

c: Sub-address [④: 1 digit]

- Fixed to 1 (31H).

(5) Details of Basic Format Part II

h: Text End Character [⑫: 1 digit/ETX (03H)] or “.” (3AH)]

- Shows text end.

i: BCC Data [⑬, ⑭: 2 digits]

- BCC (Block Check Character) data is for checking whether or not there is an abnormality in the communication data.
- If BCC operation result is a BCC error, there is no response.
- There are 4 types of BCC operation. (BCC operation type can be set on the front panel screen.)



15 Communication Setting

■ ADD (Add Operation)

Performs add operation from Start Character ① to Text End Character ⑫ on ASCII data 1 character (1 byte) unit.

■ ADD_two's cmp (Post-Add Operation 2's Complement)

Performs add operation from Start Character ① to Text End Character ⑫ on ASCII data 1 character (1 byte) unit, and takes the 2 complementary numbers of the lower 1 byte of the operation result.

■ XOR (Exclusive Disjunction) Operation

Performs XOR (Exclusive Disjunction) Operation from right after Start Character (Device Address ②) to Text End Character ⑫ on ASCII data 1 character (1 byte) unit.

■ None (BCC Operation none)

Does not perform BCC operation. BCC position is omitted. (⑬, ⑭ are omitted.)

- Regardless of data bit length (7 or 8), it is calculated by 1 byte (8 bit) unit.
- The resultant lower 1 byte data calculated above is divided into higher 4 bit and lower 4 bit and converted to ASCII data.

⑬: Higher 4 bit converted to ASCII data

⑭: Lower 4 bit converted to ASCII data

Example 1 When in Read command (R) with BCC i Add setting

①	②	③	④	⑤	⑥	⑦	⑧	⑨	⑩	⑫	⑬	⑭	⑮	⑯
STX	0	1	1	R	0	1	0	0	9	ETX	E	3	CR	LF

$$02H + 30H + 31H + 31H + 52H + 30H + 31H + 30H + 30H + 39H + 03H = 1E3H$$

Lower 1 byte of Add Result (1E3H) = E3H

⑬: "E" = 45H, ⑭: "3" = 33H

Example 2 When in Read command (R) with BCC i Add_two's cmp setting

①	②	③	④	⑤	⑥	⑦	⑧	⑨	⑩	⑫	⑬	⑭	⑮	⑯
STX	0	1	1	R	0	1	0	0	9	ETX	1	D	CR	LF

$$02H + 30H + 31H + 31H + 52H + 30H + 31H + 30H + 30H + 39H + 03H = 1E3H$$

Lower 1 byte of Add result (1E3H) = E3H

2 Complementary numbers of Lower 1 byte (E3H) = 1DH

⑬: "1" = 31H, ⑭: "D" = 44H



15 Communication Setting

Example 3 When in Read command (R) with BCC i XOR setting

①	②	③	④	⑤	⑥	⑦	⑧	⑨	⑩	⑪	⑫	⑬	⑭	⑮	⑯
@	0	1	1	R	0	1	0	0	9	:	5	9	CR	LF	

30H ⊕ 31H ⊕ 31H ⊕ 52H ⊕ 30H ⊕ 31H ⊕ 30H ⊕ 30H ⊕ 39H ⊕ 3AH = 60H

However, ⊕ = XOR (Exclusive Disjunction)

Lower 1 byte of Operation Result (60H) = 60H

⑬: "5" = 36H, ⑭: "9" = 30H

j: End Character (Delimiter) [⑮, ⑯: 1 or 2 digits /CR or CR LF]

- Shows end of the message.
- End character can be selected from the 2 types below.

⑮, ⑯: CR (0DH) (Only CR, LF is not added.)

⑮, ⑯: CR (0DH) and LF (0AH)

Note

If the following abnormalities are recognized in the Basic format part, there will be no response.

- Hardware error occurs.
- Device address and sub-address are different from the specified device address.
- Character provided in the above communication format is not in the designated position.
- BCC operation result is different from BCC data.

In data conversion, binary data is converted to ASCII data every 4 bit.

Hexadecimal numbers <A>–<F> are converted to ASCII data using uppercase characters.



15 Communication Setting

(6) Text Part Outline

Text part differs according to command type and communication response. For details on text part, refer to “15-4 (7) Details of Read Command (R)” and “15-4 (8) Details of Write Command (W).”

d: Command Type [⑤: 1 digit]

- If characters other than “R,” “W,” and “B” are recognized, there will be no response.

“R” (52H/Uppercase Character):

Shows that it is Read Command or Read Command Response.

This is used when reading (capturing) SRP30’s various data from the master computer or PLC.

“W” (57H/Uppercase Character):

Shows that it is Write Command or Write Command Response.

This is used when writing (changing) various data to the SRP30 from the master computer or PLC.

“B” (42H/Uppercase Character):

Shows that it is broadcast command.

This is used when simultaneously writing (changing) data to all the devices supporting broadcast command from the master computer or PLC.

e: Front Data Address [⑥, ⑦, ⑧, ⑨: 4 digits]

- Specifies the Read Front Data address of the Read command (R) or the Write Front Data address of the Write command (W).
- Front data address is specified through binary number 16 bit (1 word/0–65535).

16 bit data is divided into 4 bit parts and converted to ASCII data.

Binary number (16 bit)	D15, D14, D13, D12	D11, D10, D9, D8	D7, D6, D5, D4	D3, D2, D1, D0
	0 0 0 0	0 0 1 1	0 0 0 0	1 0 1 0
Hexadecimal number (Hex)	0 H "0"	3 H "3"	0 H "0"	A H "A"
ASCII data	30H ⑥	33H ⑦	30H ⑧	41H ⑨

- For more on data address, refer to “15-6 Communication Data Address List.”

f: Data No. [⑩: 1 digit]

- Specifies No. of read data of Read command (R) or No. of write data of Write command (W).
- No. of data is specified by converting binary number 4 bit data into ASCII data.
- In Read command (R), data range is specified within 1 piece: “0” (30H) –10 piece: “9” (39H) range.
No. of data of Write command (W) is fixed at 1 piece: “0” (30H).
Actual No. of data is “No. of data = specified value of No. of data + 1.”



15 Communication Setting

g: Data [⑩: No. of digit is determined by No. of data]

- Specifies the write data (change data) No. of Write command (W) or the read data during Read command (R) response.
- Data format is as follows.

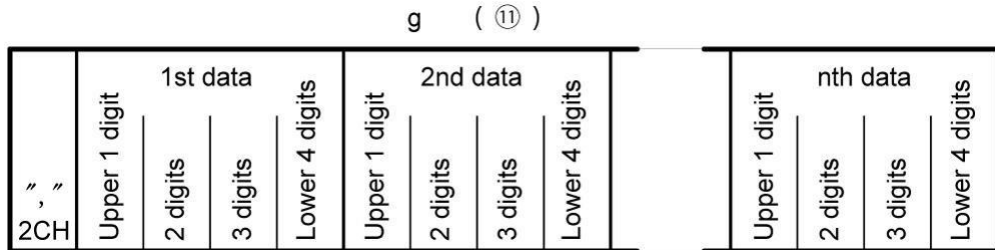

- In front of data, a comma (“,” (2CH)) is always added to show that what follows is data. No partition signal is used between data.
- No. of Data follows No. of data (f: ⑩) of communication command format.
- One data element is expressed as binary number 16 bit (1 word) unit without the decimal point. The position of the decimal point is determined by data.
- 16 bit data is divided into 4 bit parts and each is converted to ASCII data.
- For details on data, refer to “15-4 (7) Details of Read Command (R)” and “15-4 (8) Details of Write Command (W).”

e: Response Code [⑥, ⑦: 2 Digits]

- Specifies the response code for Read command (R) and Write command (W). Binary number 8 bit data (0–255) is divided into upper 4 bit and lower 4 bit and each is converted to ASCII data.

⑥: Data converted to ASCII from upper 4 bit

⑦: Data converted to ASCII from lower 4 bit

- In the case of a normal response, “0” (30H), “0” (30H) is specified.

In the case of an abnormal response, the abnormal code No. is converted to ASCII data and specified.

For details on Response Code, refer to “15-4 (10) Details of Response Code.”



15 Communication Setting

(7) Details of Read Command (R)

Read Command (R) is used to read (capture) SRP30's various data from the master computer or PLC.

■ Read Command Format

- The Text part format of Read command is shown below.

Note that Basic format part I and Basic format part II are common for all the commands and command responses.

Text part

d	e				f
⑤	⑥	⑦	⑧	⑨	⑩
R	0	4	0	0	9
52H	30H	34H	30H	30H	39H

- d (⑤) shows that it is Read command.
"R" (52H) is fixed.
- e (⑥–⑨) specifies the front data address of data to be read.
- f (⑩) specifies No. of read data (word).

- The above commands are executed as follows.

Readout front data address = 0400H (hexadecimal number)
= 0000 0100 0000 0000 (binary number)

No. of Readout data = 9H (hexadecimal number)
= 1001 (binary number)
= 9 (decimal number)

(Actual No. of data) = 10 pieces (9 + 1)

In other words, here, 10 pieces of consecutive data read from data address 0400H are specified.



■ Normal Response Format to Read Command

15 Communication Setting

- Normal response format (Text part) to Read command is shown below.

Note that all commands and command responses of Basic format part I and Basic format part II are common.

Text part

d ⑤	e ⑥ ⑦		g ⑪												
R	0	0	,	1st data			2nd data				10th data				
52H	30H	30H	2CH	0	0	1	E	0	0	7	8	0	0	7	8
				30H	30H	31H	45H	30H	30H	37H	38H	30H	30H	37H	38H

- <R (52H)>, which shows that it is the response to Read command, is inserted in d (⑤).
- Response code <00 (30H and 30H)>, which shows the normal response to Read command, is inserted in e (⑥ and ⑦).
- Response data to Read command is inserted in g (⑪).

<“,” (2CH)>, which shows the beginning of the data description in front, is inserted.

Following this, data is inserted from <data of read front data address> sequentially to No. of <No. of read data>.

Nothing is inserted in the interval between data.

1 data consists of binary number 16 bit (1 word) without the decimal point, and every 4 bit is converted to ASCII and inserted.

The position of the decimal point is determined for each data.

No. of character of response data is “No. of character = 1 + 4 x No. of read data.”

- Concretely, the following data are sequentially sent back as response data to Read command.

	Data Address		Data	
	16 bit (1 word)		16 bit (1 word)	
	Hexadecimal number	Hexadecimal number	Decimal number	
Read front data address (0400H) → 0	0400	001E	30	
1	0401	0078	120	
2	0402	001E	30	
3	0403	0000	0	
4	0404	0000	0	
5	0405	0000	0	
6	0406	03E8	1000	
7	0407	0028	40	
8	0408	001E	30	
9	0409	0078	120	
	040A	001E	30	
	040B	0000	0	
	040C	0000	0	

Read front data number (9H: 10 pcs.)



15 Communication Setting

■ Abnormal Response Format to Read Command

- The abnormal response format (Text part) to Read command is shown below.

Note that the Basic format part I and the Basic format part II are common for all the commands and command responses.

Text part

d	e	
⑤	⑥	⑦
R	0	7
52H	30H	37H

- <R (52H)>, which shows that it is the response to Read command, is inserted to d (⑤)
- The response code, which shows that it is the abnormal response of Read Command, is inserted to e (⑥ and ⑦).

Likewise, response data is not inserted during an abnormal response.

For details on the Abnormal code, refer to “15-4 (10) Details of Response Code.”

(8) Details of Write Command (W)

Write command (W) is used to write (change) various data from master computer or PLC to SRP30.

Caution

When Communication Mode Type is COM2, to use Write Command, Communication Mode has to be changed to LOC→COM.

The change of communication mode cannot be done through the front panel key.

Transmit from the master side to execute the following commands.

■ Command Format

If ADDR = 1, CTRL = STX_ETX_CR, BCC = ADD

STX	0	1	1	W	0	1	8	C	0	,	0	0	0	1	ETX	E	7	CR
02H	30H	31H	31H	57H	30H	31H	38H	43H	30H	2CH	30H	30H	30H	31H	03H	45H	37H	0DH

COM mode is confirmed if the above command is transmitted and a normal response is sent back. Parameter change is not allowed during COM mode, and if the parameter screen is displayed,  lamp lights up.



Write Command/ Broadcast Format

15 Communication Setting

- Text part format during write command is shown below.

Note that the Basic format part I and the Basic format part II are common for all the commands and command responses.

Text part

d ⑤	e ⑥ ⑦ ⑧ ⑨				f ⑩	⑪	g ⑫			
W/B	0	4	0	1	0	,	0	0	7	D
57H	30H	34H	30H	31H	30H	2CH	46H	46H	46H	46H

- d (⑤) shows that it is Write command.
Shows "W" (57H)
Shows "B" (42H)
- e (⑥-⑨) specifies the front data address of write (change) data.
- f (⑩) specifies No. of write (change) data.
No. of write data is fixed at 1 piece: "0".
- Shows g (⑪) data front "," (2CH) (⑫) specifies write (change) data.

<" , " (2CH)>, which shows the beginning of data description, is inserted in front.

Next, write data is inserted.

1 data consists of binary number 16 bit (1 word) without the decimal point, and every 4 bit is converted to ASCII and inserted.

The position of the decimal point is determined for each data.

- The above commands are executed as follows.

Write front data address = 0401H (hexadecimal number)
= 0000 0100 0000 0001 (binary number)

No. of write data = 0H (hexadecimal number)
= 0000 (binary number)
= 0 (decimal number)

(No. of Actual data) = 1 piece (0 + 1)

Write data = 007DH (hexadecimal number)
= 0000 0000 0111 1110 (binary number)
= 125 (decimal number)

In other words, it is specified that 1 piece of data (125: decimal number) is written (changed) in data address 0401H.

	Data Address		Data	
	Hexadecimal number	Decimal number	Hexadecimal number	Decimal number
Write front data address (300H)	0400	1024	00C8	200
Write front data number (9H: 10 pcs.) → 0	0401	1025	007D	125
	0402	1026	0078	120



15 Communication Setting

■ Normal Response Format to Write Command

- Normal response format (Text part) to Write command is shown below.

Note that the Basic format part I and the Basic format part II are common for all the commands and command responses.

Text part

d	e	
⑤	⑥	⑦
W	0	0
57H	30H	30H

- <W (57H)>, which shows that it is the response to Write command, is inserted in d (⑤).
- Response code <00 (30H and 30H)>, which shows that it is the normal response to write command, is inserted in e (⑥ and ⑦).

■ Abnormal Response Format to Write Command

- Abnormal response format (Text part) to Write command is shown below. Note that all commands and command responses of Basic format part I and Basic format part II are common.

Text part

d	e	
⑤	⑥	⑦
W	0	9
57H	30H	39H

- <W (57H)>, which shows that it is the response to Write command, is inserted to d (⑤).
- Response code, which shows that it is the abnormal response to Write command, is inserted to e (⑥ and ⑦).

For details on abnormal Code, refer to “15-4 (10) Details of Response Code.”

(9) Details of Broadcast Command (B)

Broadcast command (B) is used to simultaneously write (change) data from the master computer or PLC to all devices supporting Broadcast command.

There is no communication response in Broadcast command.



■ Broadcast Command Format

15 Communication Setting

For details on parameters in which broadcast is possible, refer to “15-6 Communication Data Address List.”

Example AT (auto-tuning) execution

Device address: 00, Sub-address: 1 or 2

STX	0	0	1	B	0	1	8	4	,	0	0	0	1	ETX	9	2	CR
02H	30H	30H	31H	42H	30H	31H	38H	34H	2CH	30H	30H	30H	31H	03H	39H	32H	0DH

(10) Details of Response Code

■ Response Code Types

Response code is always included in the communication response to Read command (R) and Write command (W).

There are 2 types of response code, namely normal response code and abnormal response code.

Response code is a binary number 8 bit data (0–255), details of which are shown in the table below.

Response Code List

Response Code		Code Type	Code Content
Binary number	ASCII		
0000 0000	“0”, “0”: 30H, 30H	Normal response	Normal response code during Read command (R), Write command (W)
0000 0001	“0”, “1”: 30H, 30H	Text part hardware error	If hardware error such as framing overrun, parity, etc. is detected in Text part data.
0000 0111	“0”, “7”: 30H, 37H	Text part format error	If Text part format is different from the fixed format.
0000 1000	“0”, “8”: 30H, 38H	Text part data format data address No. of data error	If Text part data format is different from fixed format, and when data address and No. of data are not as specified.
0000 1001	“0”, “9”: 30H, 39H	Data error	If the write data exceeds the possible setting range.
0000 1010	“0”, “A”: 30H, 41H	Execution command error	If execution command is received when execution command (MAN command, etc.) cannot be received.
0000 1011	“0”, “B”: 30H, 42H	Write mode error	Depending on data type, when Write command including for that data is received at a time when that data supposedly should not be changed.
0000 1100	“0”, “C”: 30H, 43H	Specification, option error	When Write command is received, including for specification and option data that has not been added.

■ Response Code Order of Priority

The order of priority of response code is higher the lower the value.

In the event multiple response codes occur, the response code with the highest order of priority is returned.



15 Communication Setting

15-5 MODBUS Protocol Explanation

There are two transmission modes in MODBUS protocol, namely ASCII mode and RTU mode.

(1) Transmission Mode Outline

■ ASCII Mode

The 8 bit binary data in command is divided into upper- and lower-rank 4 bit hexadecimal number, and each is transmitted respectively as ASCII characters.

Data Structure

Start bit: 1 bit

Data bit: 7 bit fix

Parity bit: Even number [EVEN], odd number [ODD], none [NONE]/selection possible

Stop bit: 1 bit, 2 bit/selection possible

Error check: LRC (longitudinal redundancy check) system

Data communication interval: No more than 1 sec.

■ RTU Mode

8 bit binary data in command is transmitted as is.

Data Structure

Start bit: 1 bit

Data bit: 8 bit fix

Parity bit: Even number [EVEN], odd number [ODD], none [NONE]/selection possible

Stop bit: 1 bit, 2 bit/selection possible

Error check: CRC-16 (cyclic redundancy check) system

Data communication interval: No more than 3.5 character transmission time



(2) Message Structure

■ ASCII Mode

This is structured so that it starts with opening character [: (colon) (3AH)] and ends with closing character CR [(carriage return) (ODH)] + [LF (line feed) (0AH)].

Header (:)	Communication address No.	Text data (Differs according to received data and sent data)	Error check LRC	Delimiter (CR)	Delimiter (LF)
---------------	------------------------------	--	--------------------	-------------------	-------------------

■ RTU Mode

This is structured so that it starts after idling for no less than 3.5 character transmission time, and ends after a lapse of idle time of no less than 3.5 character transmission time.

Idle 3.5 character	Slave address	Text data (differs according to received data and sent data)	Error check CRC	Idle 3.5 character
--------------------------	------------------	--	--------------------	--------------------------

(3) Slave Address

Slave address is the identification No. of each slave, ranging from 0 to 255.

By setting the slave address through a request message, the master specifies the slave that it communicates with.

On the side of the slave, by setting its own slave address in the response message and sending it back, it informs the master which slave is responding.

Slave address 0 is a broadcast address and can specify all the slaves. In the event of broadcast, the slave side does not return the response.

(4) Function Code

Function code is a code that directs the type of action to the slave.

Function code	Details
03 (03H)	Captures slave set value and information
06 (06H)	Write slave

Likewise, Function Code is used when the slave sends back a response message to master, to indicate whether it is a normal response (positive response) or some type of error (negative response) has occurred.

In a positive response, the original function code is set and sent back.

In a negative response, the highest-rank bit of original function code is set to 1 and sent back.

For example, if a function code is mistakenly set to 10H and a request message is sent to a slave, since it is a non-existent code, the highest-ranked bit is set to 1 and 90H is sent back.

Furthermore, during a negative response, to inform the master what type of error has occurred, an abnormal code is set to the response message data and sent back.

Abnormal code	Details
1 (01H)	Illegal function (non-existent function)
2 (02H)	Illegal data address (non-existent data address)
3 (03H)	Illegal data value (value outside setting range)



15 Communication Setting

(5) Data

The structure of data differs according to function code.

The request message from the master consists of data item, No. of data and set data.

Response message from slave consists of No. of byte and data to request, and in the case of negative response, it consists of an abnormality code.

The data validity range is -32768–32767 (8000H–7FFFH) .

(6) Error Check

Error check method differs according to the transmission mode.

■ ASCII Mode

Error check in the ASCII mode computes LRC from the slave address to the last data, and converts the calculated 8 bit data into ASCII character 2 character and sets it after the data.

LRC Computation Method

1. Creates message in RTU mode
2. Slave address to the last data are added, and substituted to X.
3. X complement (bit invert) is computed, and substituted to X.
4. 1 is added to X and substituted to X.
5. X is set as LRC after the data.
6. Message is converted to ASCII characters.

■ RTU Mode

Error check in the RTU mode computes CRC-16 from the slave address to the last data, and sets the calculated 16 bit data sequentially from low to high rank and sets it after the data.

CRC-16 Computation Method

CRC method divides the information that it should send by the generator polynomial, and adds the remainder to the back of the information and sends it.

Generator Polynomial: $X^{16} + X^{15} + X^2 + 1$

1. Initialize CRC-16 data (Let it be X). (FFFFH)
2. Take the first data and X non-XOR, and substitute it to X.
3. Shift X to the right 1 bit, and substitute it to X.
4. If there is carry as a result of shift, take XOR from Result X of (3) and fixed value (A001H), and substitute it to X. If there is no carry, go to 5.
5. Repeat 3 and 4 up to 8 shifts.
6. Take XOR of the next data and X and substitute it to X.
7. Repeat 3 to 5.
8. Repeat 3 to 5 up to the last data.
9. Set X as CRC-16, sequentially from low rank to high rank in the message, after data.



(7) Message Example

■ ASCII Mode

Device No 1, FIX Mode SV Reading

- Request message from master

Header	Slave address	Function code	Data address	No. of Data	Error check LRC	Delimiter
(:)	(01H)	(03H)	(0300H)	(0001H)	(F8H)	(CR/LF)
1	2	2	4	4	2	2

← No. of character (17)

- Slave response message when normal (in the case FIX Mode SV = 10.0°C)

Header	Slave address	Function code	No. of Response byte	Data	Error check LRC	Delimiter
(:)	(01H)	(03H)	(02H)	(0064H)	(96H)	(CR/LF)
1	2	2	2	4	2	2

← No. of character (15)

- Slave response message when abnormal (in case the data item is mistaken)

Header	Slave address	Function code	Abnormal code	Error check LRC	Delimiter
(:)	(01H)	(83H)	(02H)	(7AH)	(CR/LF)
1	2	2	2	2	2

← No. of character (11)

In the response message when an abnormality occurs, 1 is set to the highest rank bit of the function code (83H). As an error response message, an abnormality code 02H (non-existent data address) is sent back.



15 Communication Setting

Device No. 1, FIX Mode SV = 10.0°C Writing

- Request message from master

Header	Slave address	Function code	Data address	Data	Error check LRC	Delimiter
(:)	(01H)	(06H)	(0300H)	(0064H)	(92H)	(CR/LF)

1 2 2 4 4 2 2 ← No. of character (17)

- Slave response message when normal (in the case FIX Mode SV = 10.0°C)

Header	Slave address	Function code	Data address	Data	Error check LRC	Delimiter
(:)	(01H)	(06H)	(0300H)	(0064H)	(92H)	(CR/LF)

1 2 2 4 4 2 2 ← No. of character (17)

- Slave response when abnormal (in case value outside range is set)

Header	Slave address	Function code	Abnormal code	Error check LRC	Delimiter
(:)	(01H)	(86H)	(03H)	(76H)	(CR/LF)

1 2 2 2 2 2 ← No. of character (11)

In the response message when an abnormality occurs, 1 is set to the highest rank bit of the function code (86H). As an error response message, abnormality code 03H (value outside setting range) is sent back.

■ RTU Mode

Device No.1, FIX Mode SV Reading

- Request message from master

Idle 3.5 character	Slave address	Function code	Data address	No. of Data	Error check CRC	Idle 3.5 characters
	(01H)	(03H)	(0300H)	(0001H)	(844EH)	

1 1 2 2 2 ← No. of character (8)

- (Slave response message when normal (In case FIX Mode SV = 10.0°C)

Idle 3.5 character	Slave address	Function code	No. of Response Byte	Data	Error check CRC	Idle 3.5 character
	(01H)	(03H)	(02H)	(0064H)	(B9AFH)	

1 1 1 2 2 ← No. of Character (7)



15 Communication Setting

- Slave response message when abnormal (in case data item is mistaken)

Idle 3.5 character	Slave address (01H)	Function code (83H)	Abnormal code (02H)	Error check LRC (C0F1H)	Idle 3.5 character
	1	1	1	2	

← No. of character (5)

In the response message when an abnormality occurs, 1 is set to the highest rank bit of the function code (83H). As an error response message, abnormality code 02H (non-existent data address) is sent back.

Device No. 1, FIX Mode SV = 10.0°C Setting

- Request message from master

Idle 3.5 character	Slave address (01H)	Function code (06H)	Data address (0300H)	Data (0064H)	Error check CRC (8865H)	Idle 3.5 character
	1	1	2	2	2	

← No. of character (8)

- Slave response message when normal (in case FIX Mode SV = 10.0°C)

Idle 3.5 character	Slave address (01H)	Function code (06H)	Data address (0300H)	Data (0064H)	Error check CRC (8865H)	Idle 3.5 character
	1	1	2	2	2	

← No. of character (8)

- Slave response message when abnormal (in case value outside range is set)

Idle 3.5 character	Slave address (01H)	Function code (86H)	Abnormal code (03H)	Error check CRC (0261H)	Idle 3.5 character
	1	1	1	2	

← No. of character (5)

In the response message when an abnormality occurs, 1 is set to the highest rank bit of the function code (86H). As an error response message, abnormality code 03H (outside setting range) is sent back.



15 Communication Setting

15-6 Communication Data Address List

(1) Communication Data Address Outline

■ Read/Write of Data Address

Data address is a binary number (16 bit data) expressed as a hexadecimal number every 4 bit.

- R/W: Readable and writable data
- R: Read only data
- W: Write only data

If one specifies a read-only data address with a Write command (W), data address error occurs, abnormal response code "0 (30H)" and "8 (38H)" are sent back as "Text part data format, data address and No. of data error."

■ Read/write of Option-related Parameters

If parameter data address is specified regarding an option that is not installed, for both Read command (R) and Write command (W) abnormal response codes "0 (30H)" and "C (43H)" are sent back as "Specification and Option Error."

■ Parameters not Displayed on Front Panel Due to Action and Setting Specification

Even parameters that are not displayed (not used) on front panel due to action and setting specifications are still readable and writable by communication.

■ Handling Data

Since every data is a binary number (16 bit data) without a decimal point, there is a need to verify data type and presence of a decimal point.

For details on this, refer to parameters.

(Example) Representation of data with decimal point

	Hexadecimal data
20.0%	200 → 00C8
100.00°C	10000 → 2710
-40.00°C	-4000 → F060

The decimal point position of data whose unit is Digit is determined by measuring range.

Other than those above, it is handled as coded binary number (16 bit data: -32768 ~32767).

■ Executing Broadcast

Broadcast command is usable to all addresses in which a "W" command can be used.



■ Communication Data Address

Data Addr. (Hex)	Parameter name		R/W/B
0040H	Series Code 1: "SR" fix	If the 4 series codes from 0040H to 0043H are not read simultaneously, error (08) is sent back.	R
0041H	Series Code 2: "P3" fix		R
0042H	Series Code 3: "3" fix		R
0043H	Series Code 4: 0x00 fix		R
0044H	Version Information 1		R
0045H	Version Information 2		R

• The above address domain becomes a data domain of the product ID, and data becomes 8 bit unit ASCII data.

Accordingly, 2 data are shown in 1 address.

• Series code is represented as a maximum of 8 data, and 00H data is inserted to the excess domain.

(Example 1) SRP33	Address	H	L	(Example 2) SRP34	Address	H	L
	0040	"S", "R"	53H, 52H		0040	"S", "R"	53H, 52H
	0041	"P", "3"	50H, 33H		0041	"P", "3"	50H, 33H
	0042	"3"	33H, 00H		0042	"4"	34H, 00H
	0043		00H, 00H		0043		00H, 00H

0100H	PV Value (Measured value)	*1	R
0101H	Execution SV Value		R
0102H	Controller Output 1		R
0103H	Controller Output 2		R
0104H	Action Flag	*2 bit compatible	R
0105H	Event Output Flag	*2 bit compatible	R
0106H	Execution SV No.		R
0107H	Execution PID No.		R
0108H	Remote Input Value		R
0109H	HC1 Current Value	*1	R
010AH	HC2 Current Value	*1	R
010BH	DI Input State Flag	*2 bit compatible	R

010DH	Event Latch Output Flag	*2 bit compatible	R
010EH	Event Relay ON/OFF Flag	*2 bit compatible	R

0110H	Input Unit:	0: °C, 1: °F, 2: K	R
0111H	Input Range		R
0112H	Cold Junction Compensation:	0: INT, 1: EXT	R
0113H	Display scaling Decimal Point Position		R
0114H	Display scaling Lower Limit Value		R
0115H	Display scaling Higher Limit Value		R

011CH	Input scaling Lower Limit Value		R
011DH	Input scaling Higher Limit Value		R



15 Communication Setting

Data Addr. (Hex)	Parameter Name	R/W/B
0120H	Program Action Flag *2 bit compatible	R
0121H	Program Execution Pattern No. : 1-9	R
0122H	No. of Program Execution Pattern Link: 0-30000	R
0123H	No. of Program Execution Pattern: 1-30000	R
0124H	Program Execution Step No. : 0-180	R
0125H	Program Execution Remaining Time of Step: 000:00-300:00	R
0126H	Program Execution PID No. : 1-9	R

0128H	Program Execution Pattern Link Monitor	R
0129H	No. of Program Execution Step: 1-30000	R

• Except when this instrument is on RUN status in Program Mode, the above 9 parameters are 0x7FFE.

0180H	Execution SV No.	W/B
-------	------------------	-----

0182H	Control Output1, Manual Output Value	W/B
0183H	Control Output2, Manual Output Value	W/B
0184H	Auto-tuning Execution	W/B
0185H	AUTO ⇄ MAN Switch: 0: AUTO, 1: MAN	W/B

0187H	Remote: 0: OFF, 1: ON	W/B
-------	-----------------------	-----

0189H	External SV	W/B
-------	-------------	-----

018CH	Communication Mode: 0: LOCAL, 1: COM	W/B
-------	--------------------------------------	-----

0190H	RUN ⇄ RESET Switch: 0: RESET, 1: RUN	W/B
0191H	HLD: 0: OFF, 1: ON	W/B
0192H	Advance: 0: OFF, 1: ON	W/B

0198H	Latching Alarm Release *2 bit compatible	W/B
-------	--	-----



15 Communication Setting

Data Addr. (Hex)	Parameter Name	R/W/B
0300H	FIX Mode SV1: Within SV limiter setting range	R/W/B
0301H	FIX Mode SV2: Within SV limiter setting range	R/W/B
0302H	FIX Mode SV3: Within SV limiter setting range	R/W/B
0303H	FIX Mode SV4: Within SV limiter setting range	R/W/B
0304H	FIX Mode SV5: Within SV limiter setting range	R/W/B
0305H	FIX Mode SV6: Within SV limiter setting range	R/W/B
0306H	FIX Mode SV7: Within SV limiter setting range	R/W/B
0307H	FIX Mode SV8: Within SV limiter setting range	R/W/B
0308H	FIX Mode SV9: Within SV limiter setting range	R/W/B
030AH	SV Limiter Lower Limit Value: Measuring range lower limit value– Measuring range higher limit value -1	R/W/B
030BH	SV Limiter Higher Limit Value: SV Limiter Lower limit value +1– Measuring range higher limit value	R/W/B
0314H	Remote Scaling Lower Limit Value: Within measuring range	R/W/B
0315H	Remote Scaling Higher Limit Value: Within measuring range	R/W/B
0316H	Remote Bias: -10000–10000 digit	R/W/B
0317H	Remote Filter: OFF, 1–300 sec.	R/W/B
0318H	Remote Tracking: 0: OFF, 1: ON	R/W/B
0319H	Remote PID No.: 1–9	R/W/B
031FH	Remote Ratio: 0.001–30.000 times	R/W/B
0322H	Remote Square Root Extraction: 0: OFF, 1: ON	R/W/B
0323H	Remote Low Cut: 0.0–5.0%	R/W/B



15 Communication Setting

Data Addr. (Hex)	Parameter Name	R/W/B
0400H	Output 1 Proportional Band 1: OFF, 0.1–999.9%	R/W/B
0401H	Output 1 Integral Time 1: OFF, 1–6000 sec.	R/W/B
0402H	Output 1 Derivative Time 1: OFF, 1–3600 sec.	R/W/B
0403H	Output 1 Manual Reset 1: -50.0–50.0%	R/W/B
0404H	Output 1 Hysteresis 1: 1–10000 digit	R/W/B
0405H	Output 1 Output Limiter Lower Limit Value 1: 0.0–99.9%	R/W/B
0406H	Output 1 Output Limiter Higher Limit Value 1: 0.1–100.0%	R/W/B
0407H	Output 1 SF1: OFF, 0.01–1.00	R/W/B
0408H	Output 1 Proportional Band 2: OFF, 0.1–999.9%	R/W/B
0409H	Output 1 Integral Time 2: OFF, 1–6000 sec.	R/W/B
040AH	Output 1 Derivative Time 2: OFF, 1–3600 sec.	R/W/B
040BH	Output 1 Manual Reset 2: -50.0–50.0%	R/W/B
040CH	Output 1 Hysteresis 2: 1–10000 digit	R/W/B
040DH	Output 1 Output Limiter Lower Limit Value 2: 0.0–99.9%	R/W/B
040EH	Output 1 Output Limiter Higher Limit Value 2: 0.1–100.0%	R/W/B
040FH	Output 1 SF2: OFF, 0.01–1.00	R/W/B
0410H	Output 1 Proportional Band 3: OFF, 0.1–999.9%	R/W/B
0411H	Output 1 Integral Time 3: OFF, 1–6000 sec.	R/W/B
0412H	Output 1 Derivative Time 3: OFF, 1–3600 sec.	R/W/B
0413H	Output 1 Manual Reset 3: -50.0–50.0%	R/W/B
0414H	Output 1 Hysteresis 3: 1–10000 digit	R/W/B
0415H	Output 1 Output Limiter Lower Limit Value 3: 0.0–99.9%	R/W/B
0416H	Output 1 Output Limiter Higher Limit Value 3: 0.1–100.0%	R/W/B
0417H	Output 1 SF3: OFF, 0.01–1.00	R/W/B
0418H	Output 1 Proportional Band 4: OFF, 0.1–999.9%	R/W/B
0419H	Output 1 Integral Time 4: OFF, 1–6000 sec.	R/W/B
041AH	Output 1 Derivative Time 4: OFF, 1–3600 sec.	R/W/B
041BH	Output 1 Manual Reset 4: -50.0–50.0%	R/W/B
041CH	Output 1 Hysteresis 4: 1–10000 digit	R/W/B
041DH	Output 1 Output Limiter Lower Limit Value 4: 0.0–99.9%	R/W/B
041EH	Output 1 Output Limiter Higher Limit Value 4: 0.1–100.0%	R/W/B
041FH	Output 1 SF4: OFF, 0.01–1.00	R/W/B
0420H	Output 1 Proportional Band 5: OFF, 0.1–999.9%	R/W/B
0421H	Output 1 Integral Time 5: OFF, 1–6000 sec.	R/W/B
0422H	Output 1 Derivative Time 5: OFF, 1–3600 sec.	R/W/B
0423H	Output 1 Manual Reset 5: -50.0–50.0%	R/W/B



15 Communication Setting

Data Addr. (Hex)	Parameter Name		R/W/B
0424H	Output 1 Hysteresis 5:	1-10000 digit	R/W/B
0425H	Output 1 Output Limiter Lower Limit Value 5:	0.0-99.9%	R/W/B
0426H	Output 1 Output Limiter Higher Limit Value 5:	0.1-100.0%	R/W/B
0427H	Output 1 SF5:	OFF, 0.01-1.00	R/W/B
0428H	Output 1 Proportional Band 6:	OFF, 0.1-999.9%	R/W/B
0429H	Output 1 Integral Time 6:	OFF, 1-6000 sec.	R/W/B
042AH	Output 1 Derivative Time 6:	OFF, 1-3600 sec.	R/W/B
042BH	Output 1 Manual Reset 6:	-50.0-50.0%	R/W/B
042CH	Output 1 Hysteresis 6:	1-10000 digit	R/W/B
042DH	Output 1 Output Limiter Lower Limit Value 6:	0.0-99.9%	R/W/B
042EH	Output 1 Output Limiter Higher Limit Value 6:	0.1-100.0%	R/W/B
042FH	Output 1 SF6:	OFF, 0.01-1.00	R/W/B
0430H	Output 1 Proportional Band 7:	OFF, 0.1-999.9%	R/W/B
0431H	Output 1 Integral Time 7:	OFF, 1-6000 sec.	R/W/B
0432H	Output 1 Derivative Time 7:	OFF, -3600 sec.	R/W/B
0433H	Output 1 Manual Reset 7:	-50.0-50.0%	R/W/B
0434H	Output 1 Hysteresis 7:	1-10000 digit	R/W/B
0435H	Output 1 Output Limiter Lower Limit Value 7:	0.0-99.9%	R/W/B
0436H	Output 1 Output Limiter Higher Limit Value 7:	0.1-100.0%	R/W/B
0437H	Output 1 SF7:	OFF, 0.01-1.00	R/W/B
0438H	Output 1 Proportional Band 8:	OFF, 0.1-999.9%	R/W/B
0439H	Output 1 Integral Time 8:	OFF, 1-6000 sec.	R/W/B
043AH	Output 1 Derivative Time 8:	OFF, 1-3600 sec.	R/W/B
043BH	Output 1 Manual Reset 8:	-50.0-50.0%	R/W/B
043CH	Output 1 Hysteresis 8:	1-10000 digit	R/W/B
043DH	Output 1 Output Limiter Lower Limit Value 8:	0.0-99.9%	R/W/B
043EH	Output 1 Output Limiter Higher Limit Value 8:	0.1-100.0%	R/W/B
043FH	Output 1 SF8:	OFF, 0.01-1.00	R/W/B
0440H	Output 1 Proportional Band 9:	OFF, 0.01-1.00	R/W/B
0441H	Output 1 Integral Time 9:	OFF, 0.1-999.9%	R/W/B
0442H	Output 1 Derivative Time 9:	OFF, 1-6000 sec.	R/W/B
0443H	Output 1 Manual Reset 9:	OFF, 1-3600 sec.	R/W/B
0444H	Output 1 Hysteresis 9:	1-10000 digit	R/W/B
0445H	Output 1 Output Limiter Lower Limit Value 9:	0.0-99.9%	R/W/B
0446H	Output 1 Output Limiter Higher Limit Value 9:	0.1-100.0%	R/W/B
0447H	Output 1 SF9:	OFF, 0.01-1.00	R/W/B



15 Communication Setting

Data Addr. (Hex)	Parameter Name	R/W/B
0460H	Output 2 Proportional Band 1: OFF, 0.1–999.9%	R/W/B
0461H	Output 2 Integral Time 1: OFF, 1–6000 sec.	R/W/B
0462H	Output 2 Derivative Time 1: OFF, 1–3600 sec.	R/W/B
0463H	Output 2 Dead Band 1: -19999–30000 digit	R/W/B
0464H	Output 2 Hysteresis 1: 1–10000 digit	R/W/B
0465H	Output 2 Output Limiter Lower Limit Value 1: 0.0–99.9%	R/W/B
0466H	Output 2 Output Limiter Higher Limit Value 1: 0.1–100.0%	R/W/B
0467H	Output 2 SF1: OFF, 0.01–1.00	R/W/B
0468H	Output 2 Proportional Band 2: OFF, 0.1–999.9%	R/W/B
0469H	Output 2 Integral Time 2: OFF, 1–6000 sec.	R/W/B
046AH	Output 2 Derivative Time 2: OFF, 1–3600 sec.	R/W/B
046BH	Output 2 Dead Band 2: -19999–30000 digit	R/W/B
046CH	Output 2 Hysteresis 2: 1–10000 digit	R/W/B
046DH	Output 2 Output Limiter Lower Limit Value 2: 0.0–99.9%	R/W/B
046EH	Output 2 Output Limiter Higher Limit Value 2: 0.1–100.0%	R/W/B
046FH	Output 2 SF2: OFF, 0.01–1.00	R/W/B
0470H	Output 2 Proportional Band 3: OFF, 0.1–999.9%	R/W/B
0471H	Output 2 Integral Time 3: OFF, 1–6000 sec.	R/W/B
0472H	Output 2 Derivative Time 3: OFF, 1–3600 sec.	R/W/B
0473H	Output 2 Dead Band 3: -19999–30000 digit	R/W/B
0474H	Output 2 Hysteresis 3: 1–10000 digit	R/W/B
0475H	Output 2 Output Limiter Lower Limit Value 3: 0.0–99.9%	R/W/B
0476H	Output 2 Output Limiter Higher Limit Value 3: 0.1–100.0%	R/W/B
0477H	Output 2 SF3: OFF, 0.01–1.00	R/W/B
0478H	Output 2 Proportional Band 4: OFF, 0.1–999.9%	R/W/B
0479H	Output 2 Integral Time 4: OFF, 1–6000 sec.	R/W/B
047AH	Output 2 Derivative Time 4: OFF, 1–3600 sec.	R/W/B
047BH	Output 2 Dead Band 4: -19999–30000 digit	R/W/B
047CH	Output 2 Hysteresis 4: 1–10000 digit	R/W/B
047DH	Output 2 Output Limiter Lower Limit Value 4: 0.0–99.9%	R/W/B
047EH	Output 2 Output Limiter Higher Limit Value 4: 0.1–100.0%	R/W/B
047FH	Output 2 SF4: OFF, 0.01–1.00	R/W/B
0480H	Output 2 Proportional Band 5: OFF, 0.1–999.9%	R/W/B
0481H	Output 2 Integral Time 5: OFF, 1–6000 sec.	R/W/B
0482H	Output 2 Derivative Time 5: OFF, 1–3600 sec.	R/W/B
0483H	Output 2 Dead Band 5: 19999–30000 digit	R/W/B



15 Communication Setting

Data Addr. (Hex)	Parameter Name	R/W/B
0484H	Output 2 Hysteresis 5: 1–10000 digit	R/W/B
0485H	Output 2 Output Limiter Lower Limit Value 5: 0.0–99.9%	R/W/B
0486H	Output 2 Output Limiter Higher Limit Value 5: 0.1–100.0%	R/W/B
0487H	Output 2 SF5: OFF, 0.01–1.00	R/W/B
0488H	Output 2 Proportional Band 6: OFF, 0.1–999.9%	R/W/B
0489H	Output 2 Integral Time 6: OFF, 1–6000 sec.	R/W/B
048AH	Output 2 Derivative Time 6: OFF, 1–3600 sec.	R/W/B
048BH	Output 2 Dead Band 6: -19999–30000 digit	R/W/B
048CH	Output 2 Hysteresis 6: 1–10000 digit	R/W/B
048DH	Output 2 Output Limiter Lower Limit Value 6: 0.0–99.9%	R/W/B
048EH	Output 2 Output Limiter Higher Limit Value 6: 0.1–100.0%	R/W/B
048FH	Output 2 SF6: OFF, 0.01–1.00	R/W/B
0490H	Output 2 Proportional Band 7: OFF, 0.1–999.9%	R/W/B
0491H	Output 2 Integral Time 7: OFF, 1–6000 sec.	R/W/B
0492H	Output 2 Derivative Time 7: OFF, 1–3600 sec.	R/W/B
0493H	Output 2 Dead Band 7: -19999–30000 digit	R/W/B
0494H	Output 2 Hysteresis 7: 1–10000 digit	R/W/B
0495H	Output 2 Output Limiter Lower Limit Value 7: 0.0–99.9%	R/W/B
0496H	Output 2 Output Limiter Higher Limit Value 7: 0.1–100.0%	R/W/B
0497H	Output 2 SF7: OFF, 0.01–1.00	R/W/B
0498H	Output 2 Proportional Band 8: OFF, 0.1–999.9%	R/W/B
0499H	Output 2 Integral Time 8: OFF, 1–6000 sec.	R/W/B
049AH	Output 2 Derivative Time 8: OFF, 1–3600 sec.	R/W/B
049BH	Output 2 Dead Band 8: -19999–30000 digit	R/W/B
049CH	Output 2 Hysteresis 8: 1–10000 digit	R/W/B
049DH	Output 2 Output Limiter Lower Limit Value 8: 0.0–99.9%	R/W/B
049EH	Output 2 Output Limiter Higher Limit Value 8: 0.1–100.0%	R/W/B
049FH	Output 2 SF8: OFF, 0.01–1.00	R/W/B
04A0H	Output 2 Proportional Band 9: OFF, 0.1–999.9%	R/W/B
04A1H	Output 2 Integral Time 9: OFF, 1–6000 sec.	R/W/B
04A2H	Output 2 Derivative Time 9: OFF, 1–3600 sec.	R/W/B
04A3H	Output 2 Dead Band 9: -19999–30000 digit	R/W/B
04A4H	Output 2 Hysteresis 9: 1–10000 digit	R/W/B
04A5H	Output 2 Output Limiter Lower Limit Value 9: 0.0–99.9%	R/W/B
04A6H	Output 2 Output Limiter Higher Limit Value 9: 0.1–100.0%	R/W/B
04A7H	Output 2 SF9: OFF, 0.01–1.00	R/W/B



Data Addr. (Hex)	Parameter Name	R/W/B
04C0H	Zone PID Zone 1SP: Within measuring range	R/W/B
04C1H	Zone PID Zone 2SP: Within measuring range	R/W/B
04C2H	Zone PID Zone 3SP: Within measuring range	R/W/B
04C3H	Zone PID Zone 4SP: Within measuring range	R/W/B
04C4H	Zone PID Zone 5SP: Within measuring range	R/W/B
04C5H	Zone PID Zone 6SP: Within measuring range	R/W/B
04C6H	Zone PID Zone 7SP: Within measuring range	R/W/B
04C7H	Zone PID Zone 8SP: Within measuring range	R/W/B
04C8H	Zone PID Zone 9SP: Within measuring range	R/W/B
04CAH	Zone Hysteresis: 0-10000 digit	R/W/B
04CBH	Zone PID: 0: OFF, 1: SV, 2: PV	R/W/B
04DFH	Hysteresis Mode: 0: CENTER, 1: SV_OFF, 2: SV_ON	R/W/B
04E0H	Bar 1 Display Mode: OUT1-ECNT	R/W/B
04E1H	Bar 1 Scaling: 0.1-100.0%	R/W/B
04E4H	Bar 2 Display Mode: OUT1-ECNT	R/W/B
04E5H	Bar 2 Scaling: 0.1-100.0%	R/W/B
04FEH	EV Output on Reset: 0: OFF, 1: ON	R/W/B



Data Addr. (Hex)	Parameter Name	R/W/B
0500H	Alarm 1 Code	R/W/B
0502H	Alarm 1 Hysteresis: 1–9999 digit	R/W/B
0503H	Alarm 1 Standby Action oFF: Standby Action none 1: When power is applied, when switched RESET→ RUN, standby 2: When power is applied, when switched RESET→ RUN, when execution SV is changed, Standby 3: Control Mode (Standby Action none)	R/W/B
0504H	Alarm 1 Delay Time: 0–9999 sec.	R/W/B
0505H	Alarm 1 Latching/Output Characteristics *3	R/W/B
0508H	Alarm 2 Code	R/W/B
050AH	Alarm 2 Hysteresis: 1–9999 digit	R/W/B
050BH	Alarm 2 Standby Action oFF: Standby Action none 1: When power is applied, when switched RESET→ RUN, standby 2: When power is applied, when switched RESET→ RUN, when execution SV is changed, Standby 3: Control Mode (Standby Action none)	R/W/B
050CH	Alarm 2 Delay Time: 0–9999 sec.	R/W/B
050DH	Alarm 2 Latching/Output Characteristics *3	R/W/B
0510H	Alarm 3 Code	R/W/B
0512H	Alarm 3 Hysteresis: 1–9999 digit	R/W/B
0513H	Alarm 3 Standby Action oFF: Standby Action none 1: When power is applied, when switched RESET→ RUN, standby 2: When power is applied, when switched RESET→ RUN, when execution SV is changed, Standby 3: Control Mode (Standby Action none)	R/W/B
0514H	Alarm 3 Delay Time: 0–9999 sec.	R/W/B
0515H	Alarm 3 Latching/Output Characteristics *3	R/W/B



Data Addr. (Hex)	Parameter Name	R/W/B
0518H	Alarm 4 Code	R/W/B

051AH	Alarm 4 Hysteresis: 1-9999 digit	R/W/B
051BH	Alarm 4 Standby Action oFF: Standby Action none 1: When power is applied, when switched RESET→ RUN, standby 2: When power is applied, when switched RESET→ RUN, when execution SV is changed, Standby 3: Control Mode (Standby Action none)	R/W/B
051CH	Alarm 4 Delay Time: 0-9999 sec.	R/W/B
051DH	Alarm 4 Latching/Output Characteristics *3	R/W/B

0520H	DO1 Code	R/W/B
-------	----------	-------

0522H	DO1 Hysteresis: 1-9999 digit	R/W/B
0523H	DO1 Standby Action oFF:Standby Action none 1: When power is applied, when switched RESET→ RUN, standby 2: When power is applied, when switched RESET→ RUN, when execution SV is changed, Standby 3: Control Mode (Standby Action none)	R/W/B
0524H	DO1 Delay Time: 0-9999 sec	R/W/B
0525H	DO1 Latching/Output Characteristics *3	R/W/B

0528H	DO2 Code	R/W/B
-------	----------	-------

052AH	DO2 Hysteresis: 1-9999 digit	R/W/B
052BH	DO2 Standby Action oFF: Standby Action none 1: When power is applied, when switched RESET→ RUN, Standby 2: When power is applied, when switched RESET→ RUN, When execution SV is changed, Standby 3: Control Mode (Standby Action none)	R/W/B
052CH	DO2 Delay Time: 0-9999 sec.	R/W/B
052DH	DO2 Latching/Output Characteristics *3	R/W/B



Data Addr. (Hex)	Parameter Name	R/W/B
0530H	DO3 Code	R/W/B
0532H	DO3 Hysteresis: 1–9999 digit	R/W/B
0533H	DO3 Standby Action oFF: Standby Action none 1: When power is applied, when switched RESET→ RUN, standby 2: When power is applied, when switched RESET→ RUN, when execution SV is changed, Standby 3: Control Mode (Standby Action none)	R/W/B
0534H	DO3 Delay Time: 0–9999 sec.	R/W/B
0535H	DO3 Latching/Output Characteristics *3	R/W/B
0538H	DO4 Code	R/W/B
053AH	DO4 Hysteresis: 1–9999 digit	R/W/B
053BH	DO4 Standby Action oFF: Standby Action none 1: When power is applied, when switched RESET→ RUN, standby 2: When power is applied, when switched RESET→ RUN, when execution SV is changed, Standby 3: Control Mode (Standby Action none)	R/W/B
053CH	DO4 Delay Time: 0–9999 sec.	R/W/B
053DH	DO4 Latching/Output Characteristics *3	R/W/B
0540H	DO5 Code	R/W/B
0542H	DO5 Hysteresis: 1–9999 digit	R/W/B
0543H	DO5 Standby Action oFF: Standby Action none 1: When power is applied, when switched RESET→ RUN, standby 2: When power is applied, when switched RESET→ RUN, when execution SV is changed, Standby 3: Control Mode (Standby Action none)	R/W/B
0544H	DO5 Delay Time: 0–9999 sec.	R/W/B
0545H	DO5 Latching/Output Characteristics *3	R/W/B



Data Addr. (Hex)	Parameter Name	R/W/B
0548H	DO6 Code	R/W/B
054AH	DO6 Hysteresis: 1–9999 digit	R/W/B
054BH	DO6: Standby Action oFF: Standby Action none 1: When power is applied, when switched RESET→ RUN, standby 2: When power is applied, when switched RESET→ RUN, when execution SV is changed, Standby 3: Control Mode (Standby Action none)	R/W/B
054CH	DO6 Delay Time: 0–9999 sec.	R/W/B
054DH	DO6 Latching/Output Characteristics *3	R/W/B
0580H	DI1 Mode	R/W/B
0581H	DI2 Mode	R/W/B
0582H	DI3 Mode	R/W/B
0583H	DI4 Mode	R/W/B
0584H	DI5 Mode	R/W/B
0585H	DI6 Mode	R/W/B
0586H	DI7 Mode	R/W/B
0590H	CT1 HB Level Value: OFF, 0.1–50.0 A	R/W/B
0591H	CT1 HL Level Value: OFF, 0.1–50.0 A	R/W/B
0597H	CT1 Mode: 0: OUT1, 1: OUT2	R/W/B
0598H	CT2 HB Level Value: OFF, 0.1–50.0 A	R/W/B
0599H	CT2 HL Level Value: OFF,0.1–50.0 A	R/W/B
059FH	CT2 Mode: 0: OUT1, 1: OUT2	R/W/B
05A0H	Analog Output Mode: 0: OUT1, 1: OUT2	R/W/B
05A1H	Analog Output Scaling Lower Limit Value	PV/SV: Within measuring range
05A2H	Analog Output Scaling Higher Limit Value	OUT1, OUT2: 0.0–100.0% DEV: -100.0–100.0%



Data Addr. (Hex)	Parameter Name	R/W/B
05B0H	Communication Memory Mode	R/W/B
05B1H	Communication Mode Type	R/W/B
05B2H	Time Setting Mode: 0: HEX, 1: BCD	R/W/B
05B4H	Analog Output Limiter Lower Limit Value: 0.0–99.9%	R/W/B
05B5H	Analog Output Limiter Higher Limit Value: Limiter Lower Limit Value up to 100.0%	R/W/B

Data Addr. (Hex)	Parameter Name	R/W/B
0600H	Output 1 Output Characteristics: 0: RA, 1: DA	R/W/B
0601H	Output 1 Proportional Cycle: 1–3000 sec.	R/W/B

0604H	Output 2 Proportional Cycle: 1–3000 sec.	R/W/B
-------	--	-------

0607H	Output 2 Output Characteristics: 0: RA, 1: DA	R/W/B
0608H	Output 1 Change Rate Limiter: OFF, 0.1–100.0 sec.	R/W/B
0609H	Output 2 Change Rate Limiter: OFF, 0.1–100.0 sec.	R/W/B
0610H	Auto-tuning Point	R/W/B
0611H	Keylock OFF: Keylock release 1: Keylock other than SV-related, AT, MAN, EV/DO action point 2: Keylock other than SV-related 3: All keylock (Except keylock parameter)	R/W/B

0619H	Output 1 Output Value on Reset: 0.0–100.0%	R/W/B
061AH	Output 1 Error Output Value: 0.0–100.0%	R/W/B

061DH	Output 2 Output Value On Reset: 0.0–100.0%	R/W/B
061EH	Output 2 Error Output Value: 0.0–100.0%	R/W/B



Data Addr. (Hex)	Parameter Name	R/W/B
0700H	PV Slope: 0.500–1.500 times	R/W/B
0701H	PV Bias: -10000–10000 digit	R/W/B
0702H	PV Filter: OFF, 1–100 sec.	R/W/B

0720H	10-segment Linear Approximation Input A1	Input LINI: Linearizer 0.00: -5.00–105.00% PV_BP: PV multi bias (PV) 0.0: Measuring range PV_BS: PV multi bias (SV) 0.0: Measuring range	R/W/B
0721H	10-segment Linear Approximation Output B1		R/W/B
0722H	10-segment Linear Approximation Input A2		R/W/B
0723H	10-segment Linear Approximation Output B2		R/W/B
0724H	10-segment Linear Approximation Input A3		R/W/B
0725H	10-segment Linear Approximation Output B3		R/W/B
0726H	10-segment Linear Approximation Input A4		R/W/B
0727H	10-segment Linear Approximation Output B4		R/W/B
0728H	10-segment Linear Approximation Input A5		R/W/B
0729H	10-segment Linear Approximation Output B5		R/W/B
072AH	10-segment Linear Approximation Input A6		R/W/B
072BH	10-segment Linear Approximation Output B6		R/W/B
072CH	10-segment Linear Approximation Input A7	Output LINI: Linearizer 0.00: -5.00–105.00% PV_BP: PV multi bias (PV) 0.0: -10000–10000 digit PV_BS: PV multi bias (SV) 0.0: -10000–10000 digit	R/W/B
072DH	10-segment Linear Approximation Output B7		R/W/B
072EH	10-segment Linear Approximation Input A8		R/W/B
072FH	10-segment Linear Approximation Output B8		R/W/B
0730H	10-segment Linear Approximation Input A9		R/W/B
0731H	10-segment Linear Approximation Output B9		R/W/B
0732H	10-segment Linear Approximation Input A10		R/W/B
0733H	10-segment Linear Approximation Output B10		R/W/B
0734H	10-segment Linear Approximation Input A11		R/W/B
0735H	10-segment Linear Approximation Output B11		R/W/B
0736H	10-segment Linear Approximation Mode:	0: OFF, 1: LINI, 2: PV_BP, 3: PV_BS	R/W/B
0737H	Low Cut:	0.0–5.0%	R/W/B
0738H	Square Root Extraction:	0: OFF 1: ON	R/W/B



Data Addr. (Hex)	Parameter Name	R/W/B
0800H	Program Mode: 0: PROG, 1: FIX	R/W/B
0802H	Start Pattern No.: 1-9	R/W/B
0805H	No. of Link Repeat: 0-30000	R/W/B
0806H	Link Information 01-02 Higher rank 8 bit/Lower rank 8 bit *3	R/W/B
0807H	Link Information 03-04 Higher rank 8 bit/Lower rank 8 bit *3	R/W/B
0808H	Link Information 05-06 Higher rank 8 bit/Lower rank 8 bit *3	R/W/B
0809H	Link Information 07-08 Higher rank 8 bit/Lower rank 8 bit *3	R/W/B
080AH	Link Information 09-10 Higher rank 8 bit/Lower rank 8 bit *3	R/W/B
0815H	FIX Switch on Program End: 0: OFF, 1: ON	R/W/B
0818H	No. of Pattern: 1-9	R/W/B
0819H	Time Unit: 0: HM, 1: MS	R/W/B
081AH	Power Failure Compensation: 0: RESET, 1: CONTINUE	R/W/B
081FH	Program End Signal Time: 1-100 sec.	R/W/B
0830H	FIX EV1 Action Point	R/W/B
0831H	FIX EV2 Action Point	R/W/B
0832H	FIX EV3 Action Point	R/W/B
0833H	FIX EV4 Action Point	R/W/B
0834H	FIX DO1 Action Point	R/W/B
0835H	FIX DO2 Action Point	R/W/B
0836H	FIX DO3 Action Point	R/W/B
0837H	FIX DO4 Action Point	R/W/B
0838H	FIX DO5 Action Point	R/W/B
0839H	FIX DO6 Action Point	R/W/B



Data Addr. (Hex)	Parameter Name	R/W/B
0900H	Pattern No. Setting: 1-9	R/W/B
0901H	Step No. Setting: 1-180	R/W/B
0902H	Pattern Start Step No.: Within No. of step	R/W/B
0903H	No. of Pattern End Step: 1-180	R/W/B

0905H	No. of Pattern Repeat Executions: 1-30000	R/W/B
0906H	Pattern Start SV Value: Within SV limiter	R/W/B
0907H	Guarantee Soak Zone: OFF, 1-10000	R/W/B
0908H	Guarantee Soak Time: 000:00-300:00	R/W/B
0909H	PV Start: 0: OFF, 1: ON	R/W/B
090AH	Loop Start Step No.: 1-No. of Step	R/W/B
090BH	Loop End Step No.: 1-No. of Step	R/W/B
090CH	No. of Step Loop Executions: 1-30000	R/W/B

090FH	Pattern Information Copy: OFF, 1-9	W/B
-------	------------------------------------	-----

0912H	Pattern Alarm 1 Level Value	R/W/B
0913H	Pattern Alarm 2 Level Value	R/W/B
0914H	Pattern Alarm 3 Level Value	R/W/B
0915H	Pattern Alarm 4 Level Value	R/W/B
0916H	Pattern DO1 Level Value	R/W/B
0917H	Pattern DO2 Level Value	R/W/B
0918H	Pattern DO3 Level Value	R/W/B
0919H	Pattern DO4 Level Value	R/W/B
091AH	Pattern DO5 Level Value	R/W/B
091BH	Pattern DO6 Level Value	R/W/B

0950H	Step SV Value: Within SV limiter	R/W/B
0951H	Step Time: 000:00-300:00	R/W/B
0952H	Step PID No.: 0-9	R/W/B
0953H	Time Signal 1 ON Time: OFF (-1), 000:00-300:00	R/W/B
0954H	Time Signal 1 OFF Time: OFF (-1), 000:00-300:00	R/W/B
0955H	Time Signal 2 ON Time: OFF (-1), 000:00-300:00	R/W/B
0956H	Time Signal 2 OFF Time: OFF (-1), 000:00-300:00	R/W/B
0957H	Time Signal 3 ON Time: OFF (-1), 000:00-300:00	R/W/B
0958H	Time Signal 3 OFF Time: OFF (-1), 000:00-300:00	R/W/B
0959H	Time Signal 4 ON Time: OFF (-1), 000:00-300:00	R/W/B



Data Addr. (Hex)	Parameter Name		R/W/B
095AH	Time Signal 4 OFF Time:	OFF(-1), 000:00–300:00	R/W/B
095BH	Time Signal 5 ON Time:	OFF(-1), 000:00–300:00	R/W/B
095CH	Time Signal 5 OFF Time:	OFF(-1), 000:00–300:00	R/W/B
095DH	Time Signal 6 ON Time:	OFF(-1), 000:00–300:00	R/W/B
095EH	Time Signal 6 OFF Time:	OFF(-1), 000:00–300:00	R/W/B
095FH	Time Signal 7 ON Time:	OFF(-1), 000:00–300:00	R/W/B
0960H	Time Signal 7 OFF Time:	OFF(-1), 000:00–300:00	R/W/B
0961H	Time Signal 8 ON Time:	OFF(-1), 000:00–300:00	R/W/B
0962H	Time Signal 8 OFF Time:	OFF(-1), 000:00–300:00	R/W/B

- Direct specification other than that of a predefined address becomes abnormal, but in case an address other than that defined is included through multiple data read during read command, return value is always 0.

* 1: Measured Value Abnormal Data SHIMADEN/MODBUS ASCII MODBUS RTU
 If PV display is Sc_HH, CJ_HH,b---- 7FFFH (37H 46H 46H 46H)/(7FH FFH) is returned.
 If PV display is Sc_LL,CJ_LL 8000H (38H 30H 30H 30H)/(80H 00H) is returned.

HB, HL Invalid Current Value

If CT current value is ----- 7FFEh (37H 46H 46H 46H)/(7FH FEH) is returned.
 If CT current value is Ct_HH 7FFFH (37H 46H 46H 46H)/(7FH FFH) is returned.
 If CT current value is Ct_LL 8000H (38H 30H 30H 30H)/(80H 00H) is returned.
 If CT Option is invalid 0000H (30H 30H 30H 30H)/(00H 00H) is returned.

Remote Input Value Abnormal Data

If remote input value is RM_HH 7FFFH (37H 46H 46H 46H)/(7FH FFH) is returned.
 If remote input value is RM_LL 8000H (38H 30H 30H 30H)/(80H 00H) is returned.
 If remote option is invalid 0000H (30H 30H 30H 30H)/(00H 00H) is returned.

* 2 bit compatibility

	D15	D14	D13	D12	D11	D10	D9	D8	D7	D6	D5	D4	D3	D2	D1	D0
Action Flag							AT/W	COM			EPTN ESV		REM	RESET	MAN	AT
Event Flag							DO6	DO5	DO4	DO3	DO2	DO1	EV4	EV3	EV2	EV1
DI Input State Flag										D17	D16	D15	D14	D13	D12	D11
Event Latch Output Flag							DO6	DO5	DO4	DO3	DO2	DO1	EV4	EV3	EV2	EV1
Event Relay ON/OFF Flag							DO6	DO5	DO4	DO3	DO2	DO1	EV4	EV3	EV2	EV1
Latching Alarm Release							DO6	DO5	DO4	DO3	DO2	DO1	EV4	EV3	EV2	EV1
Program Action Flag	PRG					UP	LVL	DW					ADV	GUA	HLD	RUN

AT/W: AT on Standby



***3 Special Setting Items**

	D15	D14	D13	D12	D11	D10	D9	D8	D7	D6	D5	D4	D3	D2	D1	D0
Latching /Output Characteristics	Alarm latching 0x00: Without 0x01: With								Output characteristics 0x00: NO 0x01: NC							
Link Information	Link Information 01								Link Information 02							

*** Handling Time data (Step Time and Time Signal ON/OFF Time)**

In the SRP 30 Series, there are two types of time data handling (model) by communication. According to "15-3(12) Time Setting Mode," either BCD mode or HEX mode is selected. In the old model (FP23, FP93, etc.), operation is done in BCD mode.

	Max parameter value	Communication data model
BCD Mode	9999	BCD
HEX Mode	30000	HEX

■ HEX Mode

HEX means hexadecimal number, and the hexadecimal numbering system is a numeral value represented by 16 as its base. In the hexadecimal number system, there are 16 types of numerals but the numbers used as characters are only 10 types from 0 to 9, so the letters of the alphabet from A to F are borrowed as numbers.

Hexadecimal numbers are represented by 16 types of numerals, namely from 0 to F, and the number increases sequentially from 0 to 1, 2, 3... and continues from 7, 8, 9 to A, B, C, being 1 digit until D, E, F, and in the next digit increase, it becomes 10 (this 10 is equivalent to the decimal number "16.").

Time data is converted to a lower-ranked unit (min. for H:M, sec. for M:S) and is written as a hexadecimal number.

When OFF, it is set to FFFF (H).

Example: Set value Lower-ranked unit conversion (decimal number) hexadecimal number
 12 hrs. 34 min. → 12 x 60 + 34 = 754 (min.) → 02F2 (H)

■ ASCII Code Table

	b7-b5	000	001	010	011	100	101	110	111
b4-b1		0	1	2	3	4	5	6	7
0000	0	NUL	TC7(DLE)	SP	0	@	P	`	p
0001	1	TC1(SOH)	DC1	!	1	A	Q	a	q
0010	2	TC2(STX)	DC2	"	2	B	R	b	r
0011	3	TC3(ETX)	DC3	#	3	C	S	c	s
0100	4	TC4(EOT)	DC4	\$	4	D	T	d	t
0101	5	TC5(ENQ)	TC8(NAK)	%	5	E	U	e	u
0110	6	TC6(ACK)	TC9(SYN)	&	6	F	V	f	v
0111	7	BEL	TC10(ETB)	'	7	G	W	g	w
1000	8	FE0(BS)	CAN	(8	H	X	h	x
1001	9	FE1(HT)	EM)	9	I	Y	i	y
1010	A	FE2(LF)	SUB	*	:	J	Z	j	z
1011	B	FE3(VT)	ESC	+	;	K	[k	{
1100	C	FE4(FF)	IS4(FS)	,	<	L	\	l	
1101	D	FE5(CR)	IS3(GS)	-	=	M]	m	}
1110	E	SO	IS2(RS)	.	>	N	^	n	~
1111	F	SI	IS1(US)	/	?	O	_	o	DEL



16 Setting Analog Output

16-1 Setting Analog Output

(1) Selection of Analog Output Type

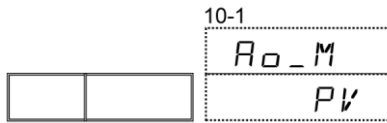

Setting range: PV, SV, DEV, out1, out2
Initial value: PV

- PV: Input measured value
- SV: Set value
- DEV: Deviation value (Deviation between PV and SV)
- out1: Control output 1
- out2: Control output 2

(2) Analog Output Scaling

Depending on Analog Output Type, Analog Output Scaling setting range differs.

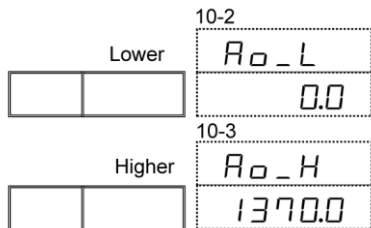

Setting range: PV, SV: Within measuring range
 OUT1, OUT2: 0–100.0%
 DEV: -100.0–100.0%
 Initial value: Lower limit value: Measuring range lower limit value
 Higher limit value: Measuring range higher limit value

Note

- Reverse scaling is possible.

(3) Analog Output Limiter

Sets Analog Output Limiter.

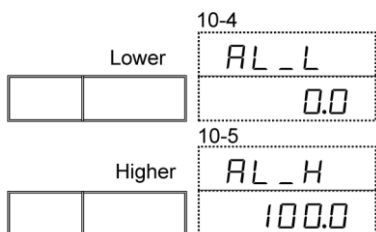

Setting range: Lower limit value: 0.0–99.9%
 Higher limit value: Limiter lower limit value + 0.1%–100.0%
 Initial value: Lower limit value: 0.0
 Higher limit value: 100.0

16-2 Analog Output Value when Input is Abnormal

- Input Over Sc_HH : 100% output
- Break Thermocouple Sc_HH : 100% output
- Sc_LL : 0% output
- Resistor ASc_HH : 100% output
- Bb_--- : 0% output
- bb_--- : 0% output

* During reverse scaling, output value is also reversed. (100% output ⇒ 0% output)



17 Setting Heater Break/Loop Alarm

17-1 Heater Break and Loop Alarm

With the heater break alarm output, if the output class of output 1 or output 2 is SSR and contact output, the heater break alarm output can be assigned to an alarm code by adding the heater break alarm option.

Further, 2 CT inputs are provided.

■ Output Type

Heater break alarm (CT1BA,CT2BA,CT_BA) Output: When control output is ON and CT current value is lower than set current value (during break), HB outputs alarm.

Loop Alarm (CT1LA,CT2LA,CT_LA) Output: When Control output is OFF and CT current value is higher than set current value (loop abnormality), HL outputs an alarm.

Event Output: Actual event output can select CT1 and CT2 and the respective OR status of CT1 and CT2.

■ Standby Action

Standby Action is either OFF or 1 (only when power supply is ON). Setting is done through the regular event standby action parameter.

■ Hysteresis

Hysteresis of heater current alarm is 0.2 A fixed. However, if CT current value is 0.0 A during HL Alarm, even if its difference with parameter value is less than 0.2 A, Event Output is put OFF.

17-2 CT (Current Sensor) Connection

Pass one load wire through the CT which is an accessory of this instrument.

Wiring is done from the CT terminal to the CT input terminal of this instrument.

There is no polarity.

For 30 A: CT QCC01

For 50 A: CT QCC02

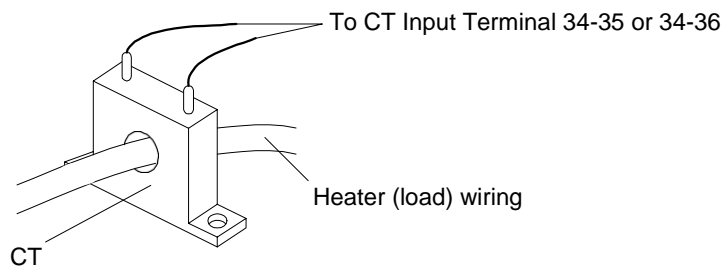



17 Setting Heater Breaker/Loop Alarm

17-3 Heater Current Value Monitor

This is a screen that displays current detected from the Current Sensor (CT).

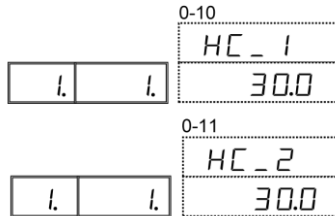

Display range: 0.0-50.0 A

- Heater current value is renewed with every control cycle, but when CT current value is invalid, ----- is displayed.
- If heater current exceeds 55.0 A , CT_HH is shown on the display screen.
- If heater current detection circuit or CT is abnormal, CT_LL is shown on the display screen.

17-4 Current Detection Selection

Set selection of the control output which performs detection through the Current Sensor (CT).

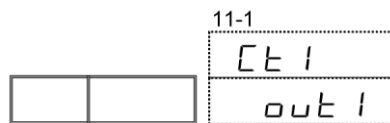

Setting range: out1, out2
Initial value: out1

17-5 Break Alarm Current Value

When control output is ON, the current value of the load wire is detected through the CT, and if it is smaller than the set current value, an abnormal alarm is output.

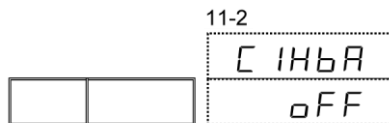

Setting range: OFF, 0.1-50.0 A
Initial value: OFF

Note

- In order to use this Heater Break Alarm, it is necessary to assign CT1LA, CT2LA, CT_LA to the event or to the external output by setting the EV/DO Action Mode.



17 Setting Heater Breaker/Loop Alarm

17-6 Loop Alarm Current Value

When the control output is OFF, the current value of the load wire is detected through the CT, and if it is bigger than the set current value, an abnormal alarm is output.

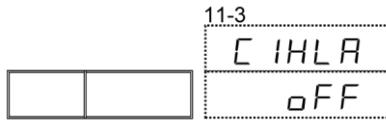

Setting range: oFF, 0.1–50.0 A
Initial value: oFF

Note

- In order to use this Loop Alarm, it is necessary to assign CT1LA, CT2LA, CT_LA to the event or to the external output by setting the EV/DO Action Mode.

17-7 Heater Break Alarm Output

If there is no Standby Action

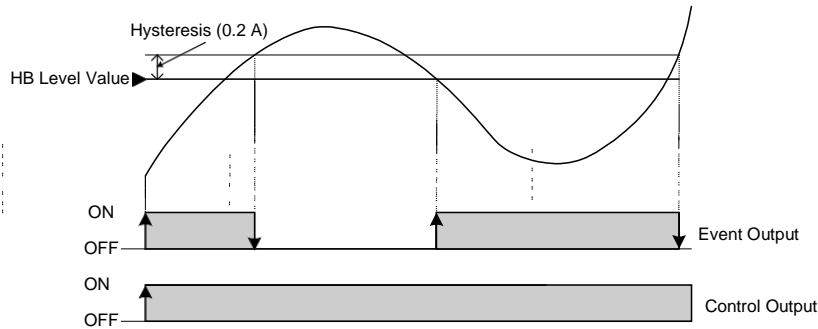

If there is Standby Action

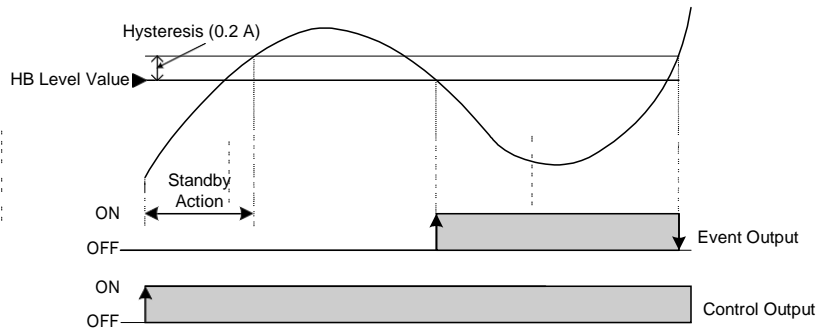



17-8 Heater Loop Alarm Output

If there is no Standby Action

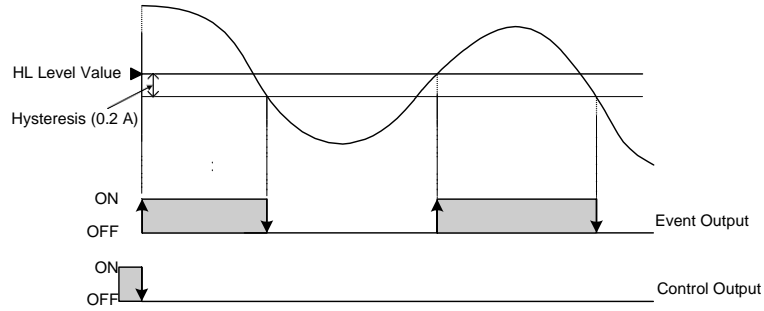

If there is Standby Action

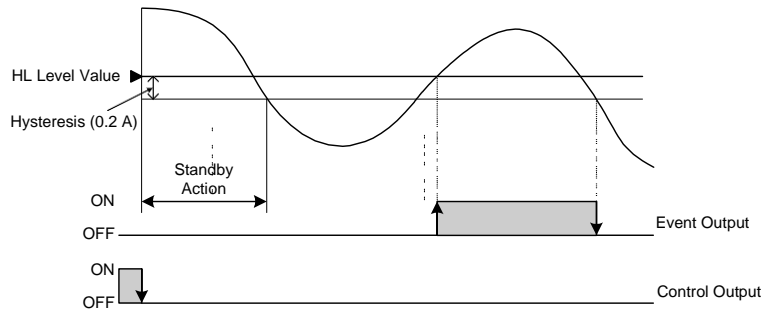



18 Setting Control Output

18 Setting Control Output

18-1 Setting Control Output

(1) Output 1 Output Characteristics

Output Characteristics are selected from RA: Reverse characteristics (heating specification), dA: Direct characteristics (cooling specification).

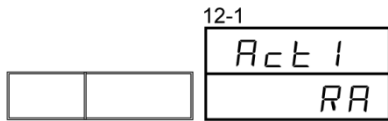

Setting range: RA (reverse characteristics),
dA (direct characteristics)

Initial value: RA (reverse characteristics)

RA (Reverse Action): The higher the measured value (PV) compared to the set value (SV), the more the output decreases. It is generally used in heating control.

dA (Direct Action): The higher the measured value (PV) compared to the parameter value (SV), the more output increases. It is generally used in cooling control.

Note

- Switching Output Characteristics cannot be done while executing auto-tuning (AT).

(2) Output 1 Proportional Cycle

Sets proportional cycle.

These are setting features during contact, and SSR drive voltage output specification.

In case of current and voltage output specification, there is no screen display.

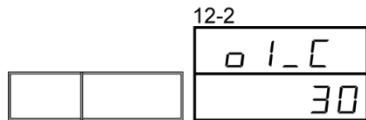

Setting range: 1–3000 sec.

Initial value: 30 sec. contact output (Y) 3 sec. SSR drive output (P)

Note

- Setting proportional cycle short through contact output will have adverse effects on output relay contact life span.
Take caution when setting proportional cycle through contact output.
- Lengthening proportional cycle through control system that has short delay time will have adverse effects on control result.

(3) Output 1 Change Rate Limiter

Sets Change Rate Limiter.

One sets this when using an operational terminal that is averse to sudden output change.

Output 1 (OUT1), output 2 (OUT2) settings are possible.

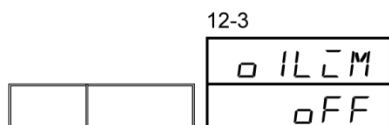

Setting range: oFF, 0.1–100.0%/sec.

Initial value: oFF



(4) Output 1 Output during Error

Set output value when error occurs.

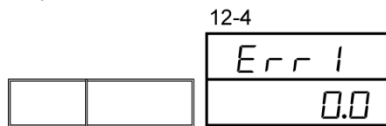

Setting range: 0.0–100.0%

Initial value: 0.0%

Note

- If ON-OFF Control (P = OFF) during Y/P Output, setting output during error to no less than 50% results in actual output during error being 100%, and setting output during error no more than 49.9% results in actual output being 0%.
- If an error occurs during RESET, output value during RESET, not output during error, is output by priority.

(5) Output 1 Reset Output Value

Set output value during RESET.

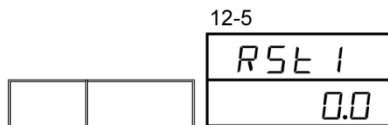

Setting range: 0.0–100.0%

Initial value: 0.0%

(6) Setting Output 2

Setting method and cautionary points for all parameters are the same as for Output 1.



19 Setting Unit/Range

19 Setting Unit/Range

19-1 Setting PV Correction Value

(1) PV Bias

This is used when there is an error in the sensor and the measuring instrument and display temperature is corrected for management purposes.

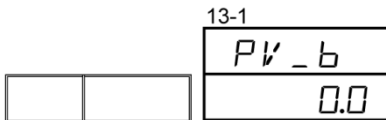

Setting range: -10000–10000 digit
Initial value: 0.0 digit

(2) PV Filter

If noise is included in the PV signal, there may be adverse effects on the control result from wobbling of the PV display and other factors.

A PV filter is used to reduce this effect and stabilize control.

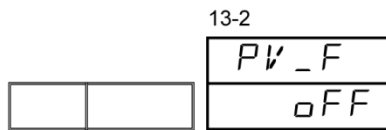

Setting range: oFF, 1–100 sec.
Initial value: oFF

Filter time constant can be set to a maximum of 100 sec.

Increasing time constant can increase noise removal capability, but adverse effects can arise in a control system with rapid response.

(3) PV Ratio

PV ratio can be set.

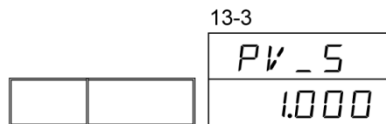

Setting range: 0.500–1.500 times
Initial value: 1.000 times

Post-adjustment PV display = A × (X – L) + L + B

(A: PV ratio, B: PV bias, X: Pre-adjustment PV, L: Scaling lower limit)

If square root extraction and 10-segment linear approximation are used in combination, the ratio is reflected in the result of the square root extraction and 10-segment linear approximation.

19-2 Setting Measuring Range

(1) Setting Range

Sets measuring range.

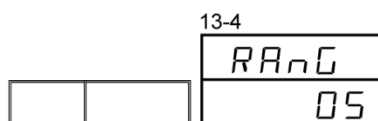

Setting range: Refer to Measuring range Code Table
Initial value: 05



19-3 Setting Unit

Sets temperature unit during input of thermocouple and RTD.

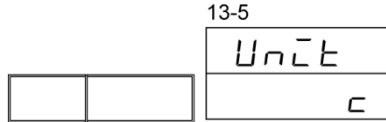

Setting range: °C, °F, K
Initial value: °C

Note

- If ranges 15 and 16 are selected, "K" will be set automatically.
- In the case of voltage input and current input, there will be no display.

19-4 Input scaling

Display input range.

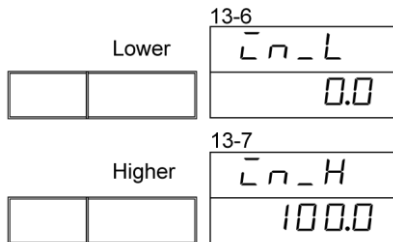

Setting range: In case of voltage/current range:
Refer to Input Types in Measuring Range Code Table

In cases other than voltage/current range:
Refer to Measuring range in Measuring Range Code Table

Minimum Span 10 digit

Initial value: Lower Limit Value: 0.0
Higher Limit Value: 1370.0

Note

- By setting the Input scaling, the selected range of the measuring range can be narrowed.

(Example)

Range	Measuring range	Input scaling	Actual measuring range	Display range
K 0 5	0.0–1370.0°C	10.0–1000.0°C	10.0–1000.0°C	10.0–1000.0°C
mV 7 1	-10 mV–20 mV	0 mV–10 mV	0 mV–10 mV	0.0–10.0 mV

- In thermocouple and RTD, with or without a decimal point, it is selectable.
If RTD goes lower than -240.0°C (below -400.0°F), scaleover is displayed.

19-5 Display scaling

This is the setting for voltage input and current input.

During RTD, TC input, setting is not possible.

This sets the measuring range (Scaling). Sc_L is PV lower limit side scaling, while Sc_H is PV upper limit side scaling.

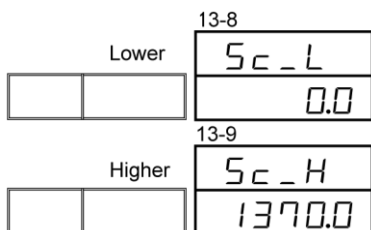

Possible setting range: -19999–32000 digit

Measuring range: Smallest span 10 digit

Largest span 52000 digit

Within the above range, optional setting possible

(Provided Sc_L < Sc_H)

Initial value:

Sc_L: 0.0

Sc_H: 100.0

In the largest span (Sc_H–Sc_L) ≤ 52000.

If Sc_L is set so that the span exceeds 52000, a value that does not exceed the span is automatically set to Sc_H.



19-6 Setting Decimal Point

(1) Position of Decimal Point

Sets the position of the decimal point that is displayed.

If the decimal point position is changed from 0.0 to 0.0000 during linear input, Displa scaling is changed from 0.0–1000.0 to 0.0000–1.0000.

Change of decimal point position of TC and RTD range and range lower than the decimal point can be changed freely.

		13-10	
		dP	Setting range: 0–0.0000
		0.0	Setting range during linear input: 0, 0.0, 0.00, 0.000, 0.0000
			Initial value: 0.0

Caution

- By changing range and input scaling, as well as decimal point position, other related parameters can be initialized. If you change any of these, please reconfirm the other parameters as well. As to parameters that can possibly be initialized, refer to “24 Parameter List.”

19-7 Setting Cold Junction Compensation

Selects either inside or outside of the instrument for execution of Cold Junction Temperature Compensation during TC input.

Normally, it is done inside but, if greater accuracy is required, it is done outside.

Only TC input is displayed.

		13-1	
		[]	Setting range: int, EXt
		int	Initial value: int

Int (Internal): Terminal temperature of this instrument is detected and then temperature compensation is done inside.

Ext (External): This is used by inputting the electromotive force of the thermocouple whose external cold junction temperature has been compensated to 0°C.



■ Measuring Range Code Table

Input Type		Code	Measuring range (°C)		Measuring range (°F)	
Full Multi Input	Thermocouple	B *1	0 1	0.0 – 1800.0 °C	0 – 3300 °F	
		R	0 2	-50.0 – 1700.0 °C	0 – 3100 °F	
		S	0 3	0.0 – 1700.0 °C	0 – 3100 °F	
		K *2	0 4	-200.0 – 400.0 °C	-300.0 – 750.0 °F	
			0 5	0.0 – 1370.0 °C	0.0 – 2500.0 °F	
		E *2	0 6	-200.0 – 1000.0 °C	-300.0 – 1800.0 °F	
		J *2	0 7	-200.0 – 1200.0 °C	-320.0 – 2200.0 °F	
		T *2	0 8	-270.0 – 400.0 °C	-450.0 – 750.0 °F	
		N	0 9	0.0 – 1300.0 °C	0.0 – 2300.0 °F	
		PL II	1 0	0.0 – 1300.0 °C	0.0 – 2300.0 °F	
		PR40-20 *3	1 1	0.0 – 1800.0 °C	0 – 3300 °F	
		C(WRe5-26)	1 2	0.0 – 2300.0 °C	0 – 4200 °F	
	U *2	1 3	-200.0 – 400.0 °C	-300.0 – 750.0 °F		
	L	1 4	0.0 – 600.0 °C	0.0 – 1100.0 °F		
Kelvin	K *4	1 5	10.0 – 350.0 K	10.00 – 350.0 K		
	AuFe-Cr *5	1 6	0.0 – 350.0 K	0.00 – 350.0 K		
RTD	Pt100	3 1	-200.0 – 850.0 °C	-300.0 – 1500.0 °F		
		3 2	-100.00 – 100.00 °C	-150.00 – 200.00 °F		
		3 3	-19.999 – 32.000 °C	0.00 – 80.00 °F		
		3 4	-199.99 – 300.00 °C	-300.00 – 600.0 °F		
	JPt100	4 1	-200.0 – 500.0 °C	-300.00 – 1000.0 °F		
		4 2	-100.00 – 100.00 °C	-150.00 – 200.00 °F		
		4 3	-19.999 – 32.000 °C	0.00 – 80.00 °F		
		4 4	-199.99 – 300.00 °C	-300.0 – 600.0 °F		
mV	-10–20 mV	7 1	Initial value: 0.0–100.0 Input scaling setting range: -19999–32000 digit Span: 10–52000 digit Decimal point position: None, lower than decimal point 1, 2, 3, 4 digit Lower limit value < Higher limit value			
	0–50 mV	7 2				
	-100–100 mV	7 3				
V	-1–2 V	8 1				
	0–5 V	8 2				
	1–5 V	8 3				
	-10–10 V	8 4				
mA	0–20 mA	9 1				
	4–20 mA	9 2				

Within the measuring range -10%–+110%, setting PV limiter (scaleover point) possible

- *1 Below 400°C and 750°F is outside accuracy
- *2 Below K, E, J, T, U -100°C and -148°F has accuracy of $\pm (0.5\%FS + 1 \text{ digit})$
- *3 PR40-20, U thermocouple accuracy $\pm (0.3\%FS + 1 \text{ digit})$
- *4 K (Kelvin) Accuracy
 10.0–30.0 K: $\pm(1.0\%FS + 1 \text{ digit})$ Provided lead wire resistance is lower than 10Ω
 31.0–70.0 K: $\pm(0.30\%FS + 1 \text{ digit})$ Provided lead wire resistance is lower than 10Ω
 71.0–350.0 K: $\pm(0.25\%FS + 1 \text{ digit})$ Provided lead wire resistance is lower than 10Ω
- *5 AuFe-Cr Accuracy $\pm(0.25\%FS + 1 \text{ K})$
- *6 If lower limit exceeds -19999 or higher limit exceeds 32700 digits, scaleover is displayed
- *7 If lower than -273.15 °C and -459.67°F, scaleover is displayed (lower than -459.67°F)
 However, if Pt is lower than 240.0°C (lower than -400°F) scaleover is displayed

(Note) If without specifications, measuring range at the time of factory shipment is set as follows.

Input	Standard/Rated value	Measuring range (Range)
Thermocouple	JIS K	0.0–1370.0°C



20 Setting of Square Root Extraction/10-segment Linear Approximation

20 Setting Square Root Extraction/10-segment Linear Approximation

20-1 Setting Square Root Extraction Function

This is a function to linearize signals with square-law characteristics such as flow rate measurement. Setting this is possible during voltage and current input.

(1) Activation of Square Root Extraction Function

The square root extraction function is activated by setting ON.



Note

- In thermocouple and RTD input, square root extraction function cannot be used but 10-segment Linear Approximation function can be used.

(2) Low Cut

This works only when square root extraction function is activated.

Low-cut processing is done first to input, and afterwards square root extraction processing is done.

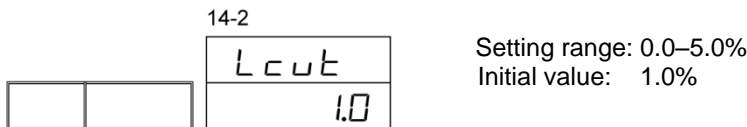

When input signal is in zero vicinity, a small change in input value results in a large change in PV. When input value is lower than set, using the function that sets PV to 0 prevents instability of action when there is noise in input signal.

Low cut set value is 0.0–5.0% of input value.

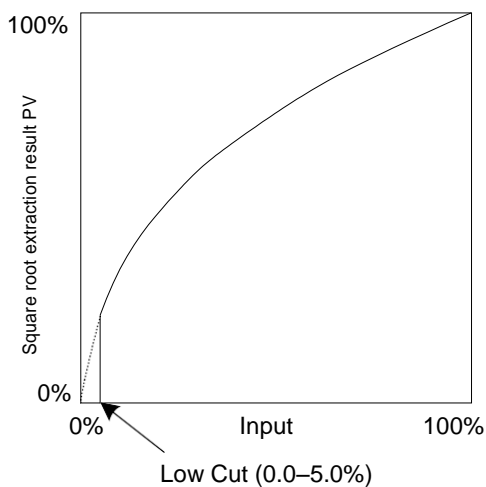

20 Setting of Square Root Extraction/10- segment Linear Approximation

20-2 Setting 10-segment Linear Approximation

10-segment Linear Approximation processing and multi-bias processing can be done.



(1) Activation of 10-Segment Linear Approximation

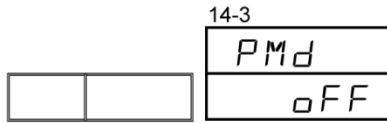

Setting range: oFF, Lini, PV_bP, PV_bS
Initial value: oFF

oFF: 10-segment Linear Approximation setting none

Lini: Linearizer

PV_bP: PV Multi-bias (PV)

PV_bS: PV Multi-bias (SV)

Note

- Only voltage input and current input can be set in Lini.

(2) Setting Contact

Sets the break point of 10-segment Linear Approximation Input. Sets PV display value (B) with respect to PV input value (A).

Further, if the value of A is lower than the value of A immediately preceding it, all values after that are invalid.

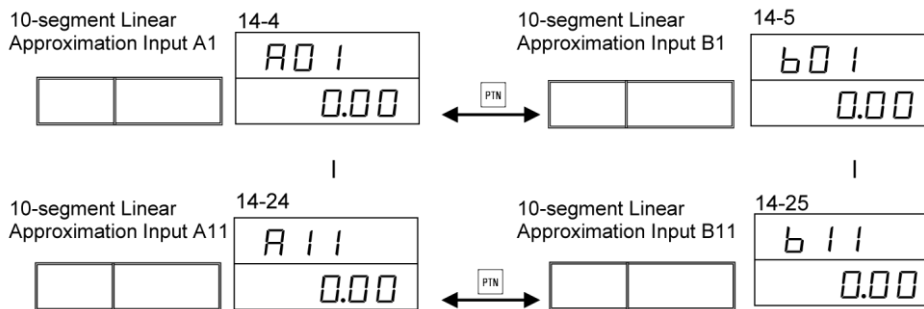

For PV input points from A1 to A11, or 11 points, it is possible to set PV display value break point for 11 points from B1 to B11.

Every break point is paired so that A1 is to B1, A2 to B2 and A11 to B11, with every interval between break points having a linear complement. This is the setting for voltage input and current input.

If 10-segment Linear Approximation mode is OFF, there will be no screen display.

10-segment Linear Approximation Input A	10-segment Linear Approximation Output B
LINI: linearizer 0.00 : -5.00-105.00%	LINI: linearizer 0.00 : -5.00-105.00%
PV_bP: PV Multi-bias (PV) 0 0.0 : Measuring range	PV_bP: PV Multi-bias (PV) 0.0 : -10000-10000 digit
PV_bS: PV multi-bias (SV) 0.0 : Measuring range	PV_bS: PV multi-bias (SV) 0.0 : -10000-10000 digit



20 Setting of Square Root Extraction/10-segment Linear Approximation

Multi-bias Processing

Divide PV value or SV value into several zones (A1–A11/maximum 10 zones) and it is possible to set multi-bias value for each zone. This is a different function from the existing PV bias.

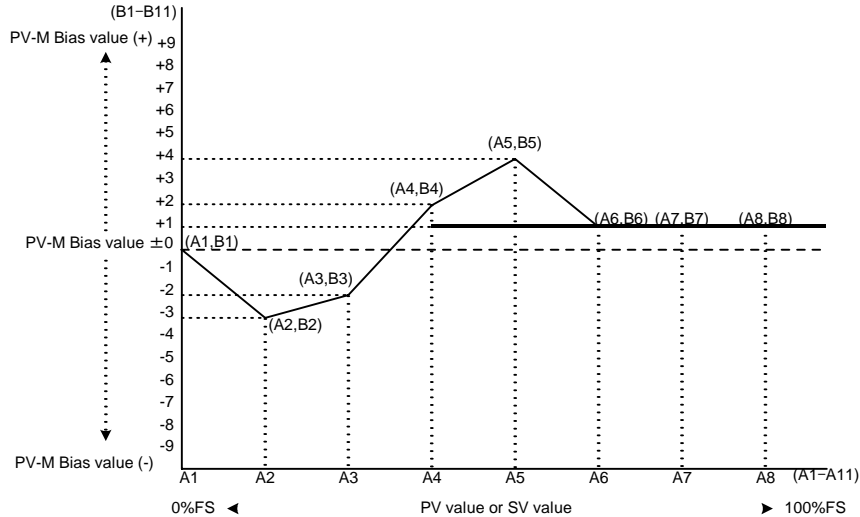

Setting example for 10-segment Linear Approximation (Linearizer)

A1, B1 to A6, B6 are used in the figure, which exemplifies when 4 break points are set halfway.

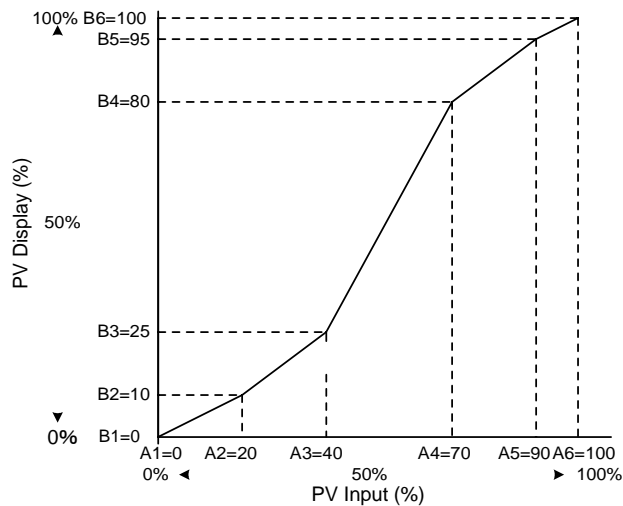

Caution

- Set so that $A_n < A_{(n+1)}$.
- If $A_n \geq A_{(n+1)}$, then $A_{(n+1)}$ and beyond becomes invalid.
- Intervals between break points have linear complement.



21 Lock and Other Settings

21-1 Keylock

If you put on the Keylock,  lights up when the parameter of the object of the lock is displayed, and it is not possible to set or change.



oFF: Keylock release

- 1: Parameters other than SV value, AT, MAN, EV/DO action point, RUN/RESET switch can be locked.
- 2: Parameters other than those related to SV can be locked.
- 3: All parameters can be locked (except keylock parameter).

21-2 USB Communication Setting

Sets whether communication is possible or not using the USB sold separately. When doing USB communication, set to ON.

Setting this instrument through USB communication is done through SRP30 loader software. SRP30 loader software and USB driver can be downloaded free of charge from our company homepage <https://shimaden.co.jp>. For details, refer to the instruction manual found in the SRP30 Loader Software Help.

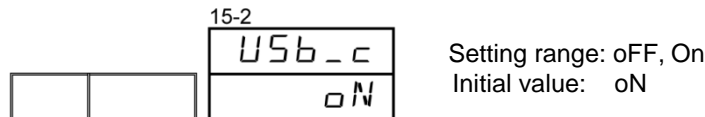

oFF: Communication using USB is not possible.

oN: Communication using USB is possible.

21-3 SV Limiter

This function prevents erroneous setting to the dangerous range. One can set SV value setting range higher limit value and lower limit value.

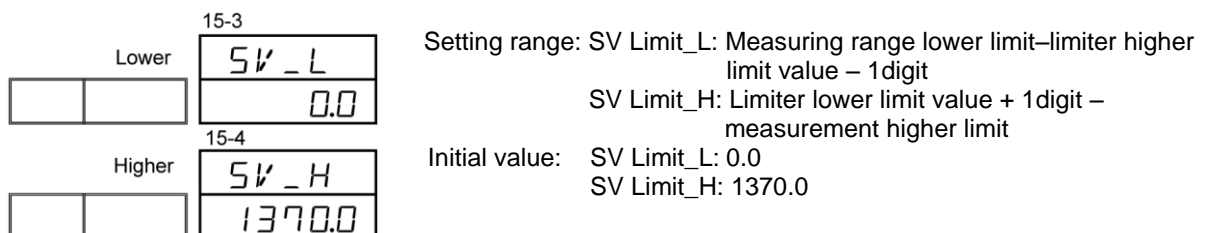



21 Lock and Other Settings

21-4 Auto-tuning Point

In PID auto-tuning execution, if you want to avoid hunting due to limit cycle in SV value, you can execute AT from a point far from SV value.

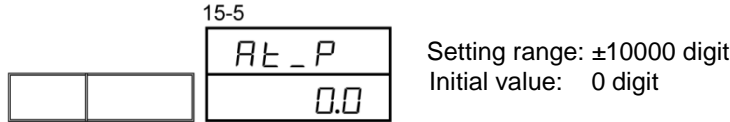

If AT point is set plus

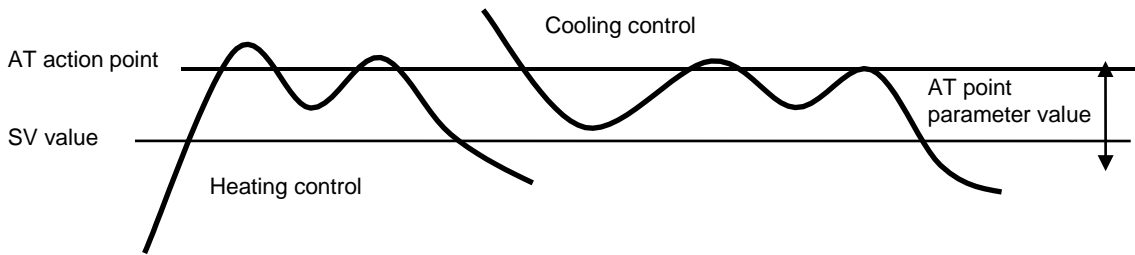

If AT point is set minus

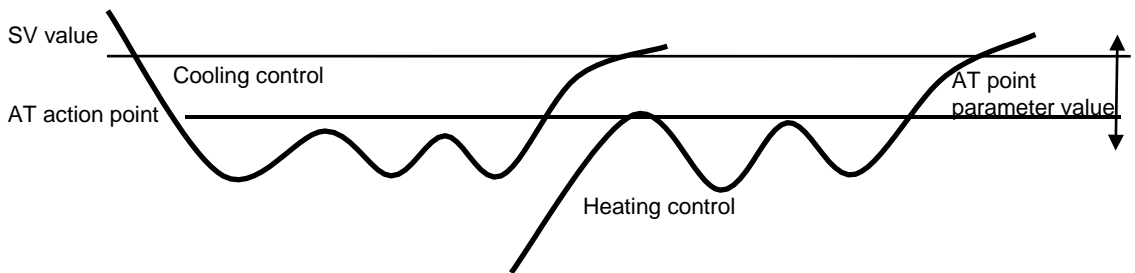

Note

- AT point is set so that AT action point is set as the deviation with SV value as standard.
- If ATP = 0, SV value becomes AT action point.
- During Zone PID SV selection, AT point becomes invalid.

21-5 Setting Program Time Unit

Sets time unit used in various categories, such as step time and time signal time. This operation is executed after putting control action on stop status (RESET).

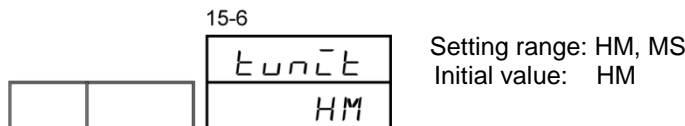

HM: __hrs.__min.

MS: __min.__sec.

Note

- Time unit cannot be changed during program execution, but change is possible during FIX execution.



21-6 Power Failure Compensation

If the power supply is cut off while the program is in execution, one can set the status to return to when the power is applied again.

15-7

		PW_on
		RESEt

Setting range: RESEt, cont
Initial value: RESEt

RESEt: When power is applied, go to RESET status.

cont: When power is applied, continue program.

* In FIX, regardless of power failure compensation setting, status immediately before power failure is returned.

21-7 No. of Pattern Used

Sets No. of pattern to be used.

15-8

		Ptn
		9

Setting range: 1-9
Initial value: 9

* Depending on No. of pattern used, the maximum No. of step of every pattern changes.

No. of Pattern	1	2	3	4	5	6	7	8	9
No. of Max. Step	180	90	60	45	36	30	25	22	20

* Changing the No. of Pattern used will initialize all step-related set values (SV, time, PID No., Time Signal).



21 Lock and Other Settings

21-8 Two-Position Action

When performing two-position action, one prevents frequent ON, OFF output action by using hysteresis.

(1) Hysteresis Mode

Sets Hysteresis Mode during ON/OFF action selection.

Likewise, the set mode will be reflected in all OUT1, 2/PID1-9.

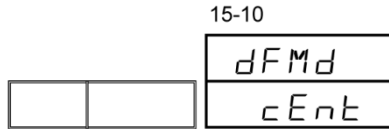

Setting range: CENT (cEnt), SVOF (SVoF), SVON (SVoN)
Initial value: CENT (cEnt)

CENT: Mode in which the center position of hysteresis is the SV value.

SVOF: Mode in which output OFF position of hysteresis is the SV value.

SVON: Mode in which output ON of hysteresis is the SV value.

① If Hysteresis Mode is CENT (cEnt)

RA action

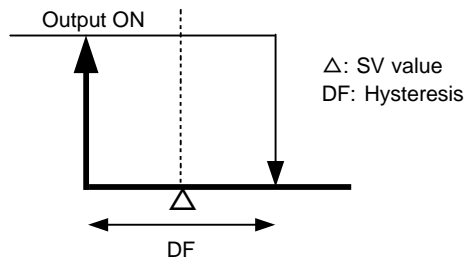

DA action

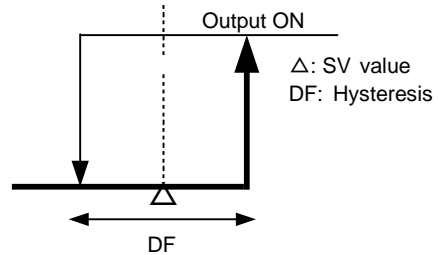

② If Hysteresis Mode is SVOF (SVoF)

RA action

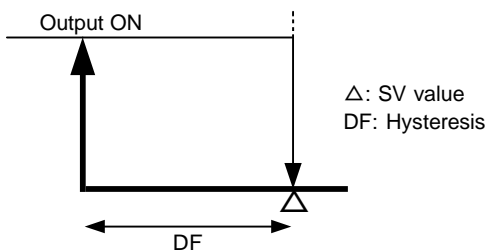

DA action

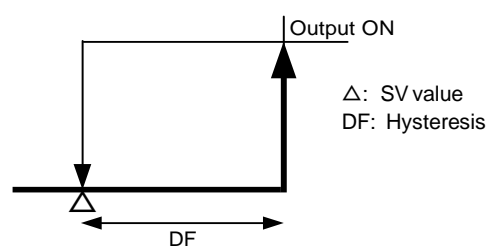

③ If Hysteresis Mode is SVON (SVoN)

RA action

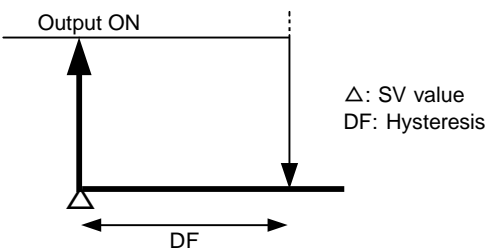

DA action

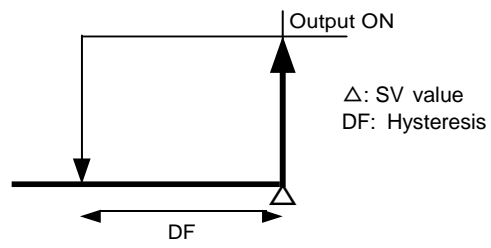



21-9 Setting Bar Display

(1) Display Mode

Sets bar display mode.

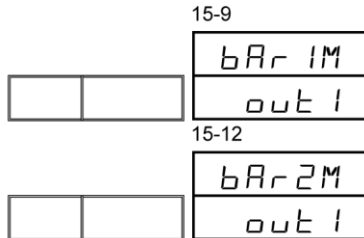

Setting range: out1, out2, dEV, StEP, Ptn, Ecnt
Initial value: out1

- out1: Output 1
- out2: Output 2
- dEV: Deviation
- StEP: Passage of step time
- Ptn: Step passage within pattern
- Ecnt: No. of program executions

(2) Scaling

Sets bar scaling.

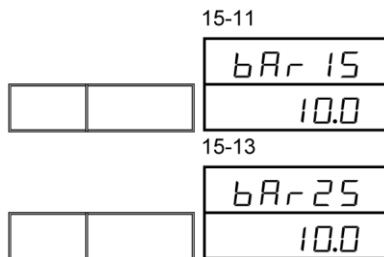

Setting range: 0.1–100.0%
Initial value: 10.0

Bar Scaling Explanation		
Example: Bar scaling at measuring range 100°C = 10.0% deviation range		
■□□□□□□□□□■□□□□□□□□■		
-10	0	+10
Example: Bar scaling at measuring range 200°C = 10.0% deviation range		
■□□□□□□□□□■□□□□□□□□■		
-20	0	+20

Note

- No display except when bar display mode is DEV

Scaling setting of Bar 2 is same as that of Bar 1.



21-10 Sampling Cycle

Selects sampling cycle. (50 ms, 100 ms, 200 ms, 500 ms)

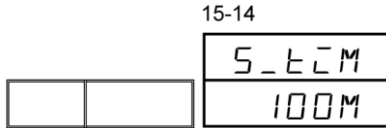

Setting range: 50M, 100M, 200M, 500M

Initial value: 100M

Note

- Cannot be changed during execution.

21-11 Parameter Setting

Parameter and Bank

SRP30 can save all parameters in multiple classes. The unit for each class is called a bank, and there are 3 banks in all, namely, ① Execution bank, ② BK1 bank (backup), and ③ BK2 (backup).

During action, operation is done based on an execution bank parameter, and parameter change through key operation and communication is always reflected in the execution bank. Direct change of BK1 bank and BK2 bank parameters is not possible. Copying of parameters between the execution bank and BK1/BK2 banks is possible.

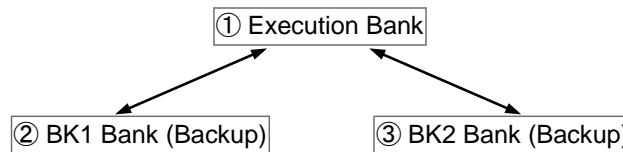

(1) Parameter Initialization

Initializes execution bank parameter and put it to factory shipment status.

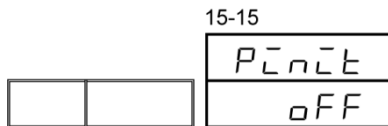

Setting range: oFF, oN

Initial value: oFF

Note

- Cannot be changed during execution.

(2) Reading Parameter

Copies backup bank content to execution bank.

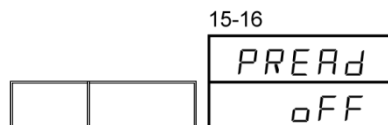

Setting range: oFF, SEt1, SEt2

Initial value: oFF

Note

- Cannot be changed during execution.



(3) Saving Parameter

Copies execution bank content to backup bank.

15-17

		PSAVE
		oFF

Setting range: oFF, SET1, SET2
Initial value: oFF

Note

- Cannot be changed during execution.

21-12 Liquid Crystal Backlight Brightness

Sets the brightness of liquid crystal backlight.

15-18

		BAK_L
		80

Setting range: 5–100%
Initial value: 80%

21-13 Event ON/OFF during Reset

Sets switch of event output ON/OFF during reset.

15-19

		RSEV
		oFF

Setting range: oFF, oN
Initial value: oFF

oFF: Event output is OFF (excluding status output).

oN: Event is output if the conditions for event action are met.

Note: This does not apply when standby action is set to Control Mode (standby action code 3 settable at “7-3 EV1 Standby Action” and “8-3 DO1 Standby Action”). If event type is status, event can be output during reset.

21-14 Program End Signal Time

Sets program end signal time.

15-20

		PESM
		1

Setting range: 1–100 sec.
Initial value: 1

21-15 FIX Switching at Program End

Check whether or not to switch to FIX mode at program end.

15-21

		PEFX
		oFF

Setting range: oFF, oN
Initial value: oFF

If FIX is assigned to external control input DI during the sequence from “8-37 DI1 Type” to “8-43 DI7 Type,” setting ON will not enable switching to FIX mode at program end. It will not switch to FIX but Reset status upon program termination.



22 Run Execution

22 Run Execution

In order to execute program control or constant value control, it is necessary to first switch to the basic screen (No. 0-0).

22-1 Operation on Basic Screen

While in reset status, the following can be done on the basic screen.

PTN key: P1–P9, SV No. (Switching of program and FIX possible)

STEP key: Program Mode: Start Step (1–180)

FIX Mode: SV No. (1–9, R)

(1) Setting Start Pattern

Sets Start Pattern before starting the program.

Pressing the **PTN** key on the basic screen group front screen increases the program pattern No. on LCD Display.

Pressing the **PTN** key after change will determine the program pattern No.

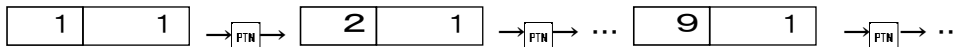

(2) Setting Start Step

Sets start step before starting the program.

Pressing the **STEP** key on the basic screen group front screen increases the program step No. on the LCD Display.

Pressing the **STEP** key after change will determine program step No.

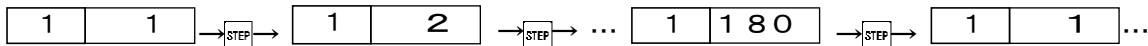

22-2 Display of Start Step No. and SV No.

Example: SRP33 (This is the same for other models in SRP30 series.)

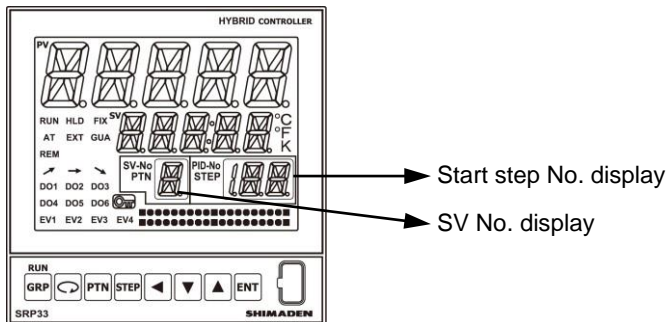

The relationship between start step No. and SV No. display in reset status is as follows.

Start step No. display	SV display	
	PRG mode	FIX mode
1	Start SV	
2–180	Prior step SV	
--		FIX SV







22-3 Control Execution and Stop Method

Please make sure to double-check the following points before executing control.

1. Is it on the basic screen?
2. Is it on the control mode (program or fix) to be executed?
3. Is it on the Start Pattern and Start Step to be executed?

If all of the above are confirmed, execute control.

Press the  +  key on the basic screen and one executes control.

Likewise, pressing the  +  key while in control execution stops control.



23 Error Display

23 Error Display

23-1 Action Check Abnormality when Power is ON

If some abnormality is detected, this instrument displays the following error codes on PV display.

Display	Cause
<i>E-EEP</i>	EEPROM abnormality
<i>E-Ad1</i>	Input 1 A/D abnormality
<i>E-Ad2</i>	CT/REM AD abnormality

Request

- If the above message is displayed, repair or replacement is necessary, so immediately shut the power supply OFF and contact your nearest Shimaden dealer.



23-2 PV Input Abnormality

If some abnormality related to PV input is detected during control execution, this instrument displays the following error codes on PV display.

Display	Cause
Sc_LL	Dropped below scaleover point (lower limit).
Sc_HH	Increased higher than scaleover point (higher limit).
	Breakage of thermocouple.
	Breakage of RTD A.
b----	1 or 2 lines of RTD B are broken. Or all RTD lines are broken.
CJ_LL	If thermocouple input cold junction compensation (-20°C) is abnormal on the lower limit side.
CJ_HH	If thermocouple input cold junction compensation (+80°C) is abnormal on the higher limit side.

Request

- If any of the above messages are displayed, please check input. If there is no abnormality in either input or heater wire, there may be other causes for the abnormal state so please contact your nearest Shimaden dealer.

23-3 Heater Current Abnormality (Option)

If an abnormality in heater current is detected during control execution, this instrument displays the following error codes on LCD.

Display	Cause
CE_LL	Heater current detection circuit or CT is abnormal.
CE_HH	Heater current exceeds 55.0 A.



24 Parameter List

24 Parameter List

Shown below are all parameters used in the SRP30 Series.
Parameters that customers cannot set are not listed.

- Display: Shows parameter codes that are displayed on screen.
- Function content: Shows display and setting content.
- Setting range: Shows settable parameter and numerical value range.
- Initial value: Shows set value at the time of factory shipment.
(Except when shipment is customized according to customer's specified value)
- Initialization: This shows the possibility that related parameters may be initialized if range and scaling, as well as decimal position, are changed.

24-1 Monitor Setting Screen Group

Function contents	Display	Initial value	Setting range (display range)	Initialization
Initial Screen	-----	-----	-----	
RESET/RUN	-----	RESET	RESET/RUN	
Output 1 Monitor	-----	-----	0.0-100.0%	
Output 2 Monitor	-----	-----	0.0-100.0%	
Execution PID No. Monitor	-----	-----	(Execution PID No.)	
Monitor of Remaining Time of Step	-----	-----	(300:00-000:00)	
Monitor of No. of Pattern Executions	P_cnt	-----	(1-30000)	
Monitor of No. of Step Loops	SLoop	-----	(1-30000)	
Pattern Link Monitor	PLink	-----	(1st-10th)	
Monitor of No. of Pattern Link Repetition	L_REP	-----	(1-30000)	
Heater Current Monitor 1	HC_1	-----	(0.0-50.0 A)	
Heater Current Monitor 2	HC_2	-----	(0.0-50.0 A)	
Remote Input Monitor	REM	-----	(Measuring range)	

* Display of Pattern No. and Step No. on Monitor Screen Group

Pattern No. and Step No. currently executed are shown during program execution.

①: Pattern No. in execution is shown.

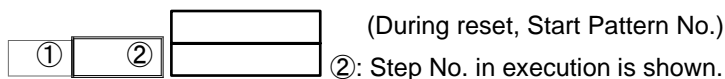

(During reset, Start Step No.)

During FIX Mode, the following is always displayed.

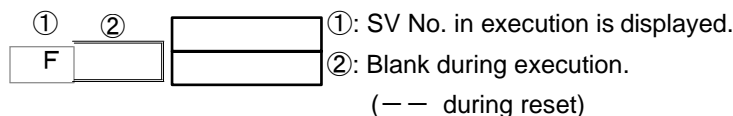



24-2 EXEC Screen Group (Group 1)

Function contents	Display	Initial value	Setting range (display range)	Initialization
Front Screen	EXEC	SEt		
AT	At	oFF	OFF/ON	
MAN	MAn	oFF	OFF/ON	
Latching Release	LAteCh	RStE 1	RSTE1-RSTE4, RSTD1-RSTE6/ALL	
COM	CoMM	LoCRL	LOCAL/COM	
HLD	HLd	oFF	OFF/ON	
Advance	AdV	oFF	OFF/ON	
Start Pattern No.	StPtn	1	1-9	
No. of Pattern Link Repetition	PLREP	oFF	OFF, 1-30000	
Pattern Link 1st	1St	oFF	OFF, 1-9	
Pattern Link 2nd	2nd	oFF	OFF, 1-9	
Pattern Link 3rd	3rd	oFF	OFF, 1-9	
Pattern Link 4th	4th	oFF	OFF, 1-9	
Pattern Link 5th	5th	oFF	OFF, 1-9	
Pattern Link 6th	6th	oFF	OFF, 1-9	
Pattern Link 7th	7th	oFF	OFF, 1-9	
Pattern Link 8th	8th	oFF	OFF, 1-9	
Pattern Link 9th	9th	oFF	OFF, 1-9	
Pattern Link 10th	10th	oFF	OFF, 1-9	

24-3 Program Screen Group (Group 2)

Function contents	Display	Initial value	Setting range (display range)	Initialization	
Front Screen	PRoG	SEt			
End Step	EStEP	20	1-180		
Start Step	SStEP	1	1-End step		
Start SV Value	StRSV	0.0	Within SV value limiter	•	
No. of Pattern Executions	PcNt	1	1-30000		
Loop Start Step No. of Step Loop	LoP_S	1	1-End step		
Loop End Step No. of Step Loop	LoP_E	20	Loop start step-end step		
No. of Step Loop Executions	LoP_R	1	1-30000		
Guarantee Soak Zone	GUARZ	oFF	OFF, 1 - 10000	•	
Guarantee Soak Time	GUARt	000:00	000:00-300:00	•	
PV Start	PVStR	oFF	OFF/ON		
Pattern EV1 Level Value	EV1Hd	2000	Higher/lower limit value: Measuring range	•	
Pattern EV2 Level Value	EV2Hd	1999			
Pattern EV3 Level Value	EV3Hd	30000	Higher/lower limit deviation: -19999- 30000		
Pattern EV4 Level Value	EV4Hd	30000			
Pattern DO1 Level Value	DO1Hd	30000	Outside higher/lower limit deviation: 0-30000		
Pattern DO2 Level Value	DO2Hd	30000			
Pattern DO3 Level Value	DO3Hd	30000			
Pattern DO4 Level Value	DO4Hd	30000			
Pattern DO5 Level Value	DO5Hd	30000			
Pattern DO6 Level Value	DO6Hd	30000			
Pattern Information Copy	CoPY	oFF	OFF,1-9		



24 Parameter List

24-4 Step Screen Group (Group 3)

Function contents	Display	Initial value	Setting range (display range)	Initialization
Step SV Value	SV	0.0	Within SV limiter	•
Step Time	ELME	000:01	000:00–300:00	
Step PID No.	PCDNO	1	0–9	
Time Signal 1 ON Time	t1ont	oFF	OFF, 000:00–300:00	
Time Signal 1 OFF Time	t1oft	oFF	OFF, 000:00–300:00	
Time Signal 2 ON Time	t2ont	oFF	OFF, 000:00–300:00	
Time Signal 2 OFF Time	t2oft	oFF	OFF, 000:00–300:00	
Time Signal 3 ON Time	t3ont	oFF	OFF, 000:00–300:00	
Time Signal 3 OFF Time	t3oft	oFF	OFF, 000:00–300:00	
Time Signal 4 ON Time	t4ont	oFF	OFF, 000:00–300:00	
Time Signal 4 OFF Time	t4oft	oFF	OFF, 000:00–300:00	
Time Signal 5 ON Time	t5ont	oFF	OFF, 000:00–300:00	
Time Signal 5 OFF Time	t5oft	oFF	OFF, 000:00–300:00	
Time Signal 6 ON Time	t6ont	oFF	OFF, 000:00–300:00	
Time Signal 6 OFF Time	t6oft	oFF	OFF, 000:00–300:00	
Time Signal 7 ON Time	t7ont	oFF	OFF, 000:00–300:00	
Time Signal 7 OFF Time	t7oft	oFF	OFF, 000:00–300:00	
Time Signal 8 ON Time	t8ont	oFF	OFF, 000:00–300:00	
Time Signal 8 OFF Time	t8oft	oFF	OFF, 000:00–300:00	

24-5 FIX Screen Group (Group 4)

Function contents	Display	Initial value	Setting range (display range)	Initialization
Front Screen	FLX	SET		
FIX Mode	FLX	oFF	OFF/ON	
FIX SV No.	FsvNo	1	1–9, REM	
FIX SV1	F-SV1	0.0	Within SV limiter	•
FIX SV2	F-SV2	0.0	Within SV limiter	•
FIX SV3	F-SV3	0.0	Within SV limiter	•
FIX SV4	F-SV4	0.0	Within SV limiter	•
FIX SV5	F-SV5	0.0	Within SV limiter	•
FIX SV6	F-SV6	0.0	Within SV limiter	•
FIX SV7	F-SV7	0.0	Within SV limiter	•
FIX SV8	F-SV8	0.0	Within SV limiter	•
FIX SV9	F-SV9	0.0	Within SV limiter	•
FIX EV1 Level Value	E1Hd	2000	Higher/lower limit value: Measuring range	•
FIX EV2 Level Value	E2Ld	1999		
FIX EV3 Level Value	E3Hd	30000		
FIX EV4 Level Value	E4Hd	30000	Higher/lower limit deviation: -1999–30000	
FIX DO1 Level Value	do1Hd	30000		
FIX DO2 Level Value	do2Hd	30000		
FIX DO3 Level Value	do3Hd	30000	Outside higher/lower limit deviation: 0–30000	
FIX DO4 Level Value	do4Hd	30000		
FIX DO5 Level Value	do5Hd	30000		
FIX DO6 Level Value	do6Hd	30000		

**24-6 Remote (REM) Screen Group (Group 5)**

Function contents	Display	Initial value	Setting range (display range)	Initialization
Front Screen	REM	SEt		
Remote Bias	REM_b	0.0	-10000-10000 digit	•
Remote Filter	REM_F	OFF	OFF, 1-300 min.	
Remote Ratio	REM_R	1.000	0.001-30.000 times	•
Remote PID	R_Pi_d	1	1-9	
Remote Scaling Lower Limit Value	REM_L	0.0	Within measuring range	•
Remote Scaling Higher Limit Value	REM_H	1370.0	Within measuring range	•
Remote Square Root Extraction	R_SQR	OFF	OFF/ON	
Remote Low Cut	RLcut	1.0	0.0-5.0%	
Remote Tracking	R_TR	OFF	OFF/ON	

24-7 PID Screen Group (Group 6)

Function contents	Display	Initial value	Setting range (display range)	Initialization
Front Screen	Pi_d	SEt		
Output 1 Proportional Band Width	P1	3.0	OFF, 0.1-999.9%	
Output 1 Hysteresis	dF1	2.0	1-10000 digit	•
Output 1 Integral Time	I1	120	OFF, 1-6000 min.	
Output 1 Derivative Time	d1	30	OFF, 1-3600 min.	
Output 1 Manual Reset	MR	0.0 50.0	-50.0-50.0%	
Output 1 Target Value Function	SF1	0.40	OFF, 0.01-1.00	
Output 1 Output Lower Limit Value	o1_L	0.0	0.0-99.9%	
Output 1 Output Higher Limit Value	o1_H	100.0	0.1-100.0%	
Output 2 Proportional Band Width	P2	3.0	OFF, 0.1-999.9%	
Output 2 Hysteresis	dF2	2.0	1-10000 digit	•
Output 2 Integral Time	I2	120	OFF, 1-6000 min.	
Output 2 Derivative Time	d2	30	OFF, 1-3600 min.	
Output 2 Dead Band	db	0.0	-19999-30000 digit	•
Output 2 Target Value Function	SF2	0.40	OFF, 0.01-1.00	
Output 2 Output Lower Limit Value	o2_L	0.0	0.0-99.9%	
Output 2 Output Lower Limit Value	o2_H	100.0	0.1-100.0%	

24-8 Zone PID Screen Group (Group 6)

Function contents	Display	Initial value	Setting range (display range)	Initialization
Front Screen	Pi_d	SEt		
Zone PID ON/OFF	ZoNE	OFF	OFF, SV, PV	
Zone 1 SP	Z1SP	0.0	Within measuring range	•
Zone 2 SP	Z2SP	0.0	Within measuring range	•
Zone 3 SP	Z3SP	0.0	Within measuring range	•
Zone 4 SP	Z4SP	0.0	Within measuring range	•
Zone 5 SP	Z5SP	0.0	Within measuring range	•
Zone 6 SP	Z6SP	0.0	Within measuring range	•
Zone 7 SP	Z7SP	0.0	Within measuring range	•
Zone 8 SP	Z8SP	0.0	Within measuring range	•
Zone 9 SP	Z9SP	0.0	Within measuring range	•
Zone Hysteresis	ZHY5	2.0	0-10000 digit	•



24-9 Event (EV) Setting Screen Group (Group 7)

Function contents	Display	Initial value	Setting range (display range)	Initialization
Front Screen	EV	SEt		
EV1 Type	E1_M	Hd	Refer to Event (EV)/DO Assignable Types.	
EV1 Action Hysteresis	E1_d	2.0	1-9999 digit	•
EV1 Standby Action	E1_c	oFF	OFF, 1, 2, 3	
EV1 Output Characteristics	E1_R	n_oPn	N_OPN,N_CLS	
EV1 Delay Time	E1_dL	oFF	OFF, 1-9999 min.	
EV1 Latching	E1_l	oFF	OFF, ON	
EV2 Type	E2_M	Ld	Refer to Event (EV)/DO Assignable Types.	
EV2 Action Hysteresis	E2_d	2.0	1-9999 digit	•
EV2 Standby Action	E2_c	oFF	OFF, 1, 2, 3	
EV2 Output Characteristics	E2_R	n_oPn	N_OPN, N_CLS	
EV2 Delay Time	E2_dL	oFF	OFF, 1-9999 min.	
EV2 Latching	E2_l	oFF	OFF, ON	
EV3 Type	E3_M	RUn	Refer to Event (EV)/DO Assignable Types.	
EV3 Action Hysteresis	E3_d	2.0	1-9999 digit	•
EV3 Standby Action	E3_c	oFF	OFF, 1, 2, 3	
EV3 Output Characteristics	E3_R	n_oPn	N_OPN,N_CLS	
EV3 Delay Time	E3_dL	oFF	OFF,1-9999 minutes	
EV3 Latching	E3_l	oFF	OFF,ON	
EV4 Type	E4_M	non	Refer to Event (EV)/DO Assignable Types.	
EV4 Action Hysteresis	E4_d	2.0	1-9999 digit	•
EV4 Standby Action	E4_c	oFF	OFF, 1, 2, 3	
EV4 Output Characteristics	E4_R	n_oPn	N_OPN, N_CLS	
EV4 Delay Time	E4_dL	oFF	OFF, 1-9999 digit	
EV4 Latching	E4_l	oFF	OFF, ON	



24-10 DO/DI Screen Group (Group 8)

Function contents	Display	Initial value	Setting range (display range)	Initialization
Front Screen	do	5Ft		
DO1 Type	do1_M	non	Refer to Event (EV)/DO Assignable Types.	
DO1 Action Hysteresis	do1_d	2.0	1-9999 digit	•
DO1 Standby Action	do1_L	OFF	OFF, 1, 2, 3	
DO1 Output Characteristics	do1_A	n_OPn	N_OPN, N_CLS	
DO1 Delay Time	do1dL	OFF	OFF, 1-9999 min.	
DO1 Latching	do1_L	OFF	OFF, ON	
DO2 Type	do2_M	non	Refer to Event (EV)/DO Assignable Types.	
DO2 Action Hysteresis	do2_d	2.0	1-9999 digit	•
DO2 Standby Action	do2_L	OFF	OFF, 1, 2, 3	
DO2 Output Characteristics	do2_A	n_OPn	N_OPN, N_CLS	
DO2 Delay Time	do2dL	OFF	OFF, 1-9999 min.	
DO3 Latching	do2_L	OFF	OFF, ON	
DO3 Type	do3_M	non	Refer to Event (EV)/DO Assignable Types.	
DO3 Action Hysteresis	do3_d	2.0	1-9999 digit	•
DO3 Standby Action	do3_L	OFF	OFF, 1, 2, 3	
DO3 Output Characteristics	do3_A	n_OPn	N_OPN, N_CLS	
DO3 Delay Time	do3dL	OFF	OFF, 1-9999 min.	
DO3 Latching	do3_L	OFF	OFF, ON	
DO4 Type	do4_M	non	Refer to Event (EV)/DO Assignable Types.	
DO4 Action Hysteresis	do4_d	2.0	1-9999 digit	•
DO4 Standby Action	do4_L	OFF	OFF, 1, 2, 3	
DO4 Output Characteristics	do4_A	n_OPn	N_OPN, N_CLS	
DO4 Delay Time	do4dL	OFF	OFF, 1-9999 min.	
DO4 Latching	do4_L	OFF	OFF, ON	
DO5 Type	do5_M	non	Refer to Event (EV)/DO Assignable Types.	
DO5 Action Hysteresis	do5_d	2.0	1-9999 digit	•
DO5 Standby Action	do5_L	OFF	OFF, 1, 2, 3	
DO5 Output Characteristics	do5_A	n_OPn	N_OPN, N_CLS	
DO5 Delay Time	do5dL	OFF	OFF, 1-9999 min.	
DO5 Latching	do5_L	OFF	OFF, ON	
DO6 Type	do6_M	non	Refer to Event (EV)/DO Assignable Types.	
DO6 Action Hysteresis	do6_d	2.0	1-9999 digit	•
DO6 Standby Action	do6_L	OFF	OFF, 1, 2, 3	
DO6 Output Characteristics	do6_A	n_OPn	N_OPN, N_CLS	
DO6 Delay Time	do6dL	OFF	OFF, 1-9999 min.	
DO6 Latching	do6_L	OFF	OFF, ON	
DI1 Type	dL1c	non	Refer to Input Type Assignment Table.	
DI2 Type	dL2c	non		
DI3 Type	dL3c	non		
DI4 Type	dL4c	non		
DI5 Type	dL5c	non		
DI6 Type	dL6c	non		
DI7 Type	dL7c	non		



24-11 Communication Setting Screen Group (Group 9)

Function contents	Display	Initial value	Setting range (display range)	Initialization
Front Screen	COM	SET		
Communication Protocol	Prot	SHIMA	SHIMA/ASC/RTU	
Communication Address	Addr	1	1-255	
Communication Data	DATA	7E1	7E1-802	
Start Character	SchA	STXCR	STXCR/STXLF/ATT	
BCC Operation	bcc	ADD	NON/ADD/ADD2/XOR	
Communication Speed	bps	9600	2400-38400 BPS	
Communication Delay Time	DELY	20	1-500 minutes	
Communication Memory Mode	MEM	EEP	EEP/RAM/R_E	
Communication Mode Type	coMMd	COM1	COM1/COM2	
Master Function ON/OFF	MASt	oFF	OFF/MASt1/MASt2	
Slave Start Address	S_Adr	2	BCAS, Communication address +1-255	
Slave End Address	E_Adr	2	Start address -Start address + 29	
Time Setting Mode	HEX_M	HEX	HEX, BCD	

24-12 Analog Output Setting Screen Group (Group 10)

Function contents	Display	Initial value	Setting range (display range)	Initialization
Front Screen	ROUT	SET		
Analog Output Type	Ro_M	PV	PV/SV/DEV/OUT1/OUT2	
Analog Output Scaling Lower Limit Value	Ro_L	0.0	PV/SV: Measuring range OUT1/OUT2: 0.0-100.0% DEV: -1000-1000 digit	•
Analog Output Scaling Higher Limit Value	Ro_H	1370.0		•
Analog Output Limiter Lower Limit Value	AL_L	0.0	0.0-99.9%	
Analog Output Limiter Higher Limit Value	AL_H	100.0	Lower limiter value-100.0%	

24-13 Heater Break/Loop Alarm Setting Screen Group (Group 11)

Function contents	Display	Initial value	Setting range (display range)	Initialization
Front Screen	Hb	SET		
CT1 Current Detection Selection	CE1	OUT1	OUT1/OUT2	
CT1 Break Alarm Current Value	CHbA	oFF	OFF, 0.0-50.0A	
CT1 Loop Alarm Current Value	CHLA	oFF	OFF, 0.0-50.0A	
CT2 Current Detection Selection	CE2	OUT1	OUT1/OUT2	
CT2 Break Alarm Current Value	CHbA	oFF	OFF, 0.0-50.0A	
CT2 Loop Alarm Current Value	CHLA	oFF	OFF, 0.0-50.0A	



24-14 Control Output Screen Group (Group 12)

Function contents	Display	Initial value	Setting range (display range)	Initialization
Front Screen	Ctrl	SEt		
Output 1 Output Characteristics	Act1	RA	RA/DA	
Output 1 Proportional Cycle	o1_c	Y:30/P:3	1-3000 min.	
Output 1 Output Change Rate Limiter	o1_LCM	oFF	OFF, 0.1-100.0%/min.	
Output 1 Error Output Value	Err1	0.0	0.0-100.0%	
Output 1 Output Value on Reset	RSt1	0.0	0.0-100.0%	
Output 2 Output Characteristic	Act2	DA	RA/DA	
Output 2 Proportional Cycle	o2_c	Y:30/P:3	1-3000 min.	
Output 2 Rate Limiter	o2_LCM	oFF	OFF, 0.1-100.0%/min.	
Output 2 Error Output Value	Err2	oFF	0.0-100.0%/min.	
Output 2 Output Value on Reset	RSt2	oFF	0.0-100.0%/min.	

24-15 Unit/Range Setting Screen Group (Group 13)

Function contents	Display	Initial value	Setting range (display range)	Initialization
Front Screen	Un_RG	SEt		
PV Bias	PV_b	0.0	-10000-10000 digit	•
PV Filter	PV_f	oFF	OFF, 1-100 min.	
PV Slope	PV_s	1.000	0.500-1.500 times	•
Measuring Range	RRnG	05	Refer to Measuring Range Code Table.	
Temperature Unit	Un_t	C	°C/°F/K	
Input Scaling Lower Limit Value	Ln_L	0.0	In case of LINI range: Refer to Input type of Measuring Range Code Table.	•
Input Scaling Higher Limit Value	Ln_H	1370.0	In case of outside LINI range: Refer to Measuring range of Measuring Range Code Table. Minimum span 10 digit	•
Display Scaling Lower Limit Value	Sc_L	0.0	Possible setting range: -19999-32000 digit Measuring range: Minimum span 10 digit Maximum span 52000 digit	•
Display Scaling Higher Limit Value	Sc_H	1370.0	Within the above, optional setting possible (Provided Sc_L < Sc_H)	•
Position of Decimal Point	dP	0.0	0-0.0000	•
Cold Junction Compensation	CJ	int	INT/EXT	



24-16 Square Root Extraction/10-Segment Operation Setting Group (Group 14)

Function contents	Display	Initial value	Setting range (display range)	Initialization
Front Screen	SQ_PM	SEt		
Square Root Extraction	SQR	OFF	OFF/ON	•
Square Root Extraction Low Cut	LcUt	1.0	0.0–5.0%	•
10-segment Linear Approximation Mode	PMd	OFF	OFF/LINI/PV_BP/PV_BS	•
10-segment Linear Approximation Input A1	A01		LINI: Linearizer Initial value : 0.00 Setting range: -5.00–105.00% PV_BP: PV multi bias (PV) Initial value : 0.0 Setting range: Measuring range PV_BS: PV multi bias (SV) Initial value : 0.0 Setting range: Measuring range	•
10-segment Linear Approximation Input A2	A02			
10-segment Linear Approximation Input A3	A03			
10-segment Linear Approximation Input A4	A04			
10-segment Linear Approximation Input A5	A05			
10-segment Linear Approximation Input A6	A06			
10-segment Linear Approximation Input A7	A07			
10-segment Linear Approximation Input A8	A08			
10-segment Linear Approximation Input A9	A09			
10-segment Linear Approximation Input A10	A10			
10-segment Linear Approximation Input A11	A11			
10-segment Linear Approximation Output B1	B01		LINI: Linearizer Initial value: 0.00 Setting range: -5.00–105.00% PV_BP: PV multi bias (PV) Initial value : 0.0 Setting range: -10000–10000 digit PV_BS: PV multi bias (SV) Initial value : 0.0 Setting range: -10000–10000 digit	•
10-segment Linear Approximation Output B2	B02			
10-segment Linear Approximation Output B3	B03			
10-segment Linear Approximation Output B4	B04			
10-segment Linear Approximation Output B5	B05			
10-segment Linear Approximation Output B6	B06			
10-segment Linear Approximation Output B7	B07			
10-segment Linear Approximation Output B8	B08			
10-segment Linear Approximation Output B9	B09			
10-segment Linear Approximation Output B10	B10			
10-segment Linear Approximation Output B11	B11			



24-17 Lock and other Screen Setting (Group 15)

Function contents	Display	Initial value	Setting range (display range)	Initialization
Front Screen	LK_Et	SEt		
Keylock	LoCK	oFF	OFF,1, 2, 3	
USB Communication	USb_c	oN	OFF/ON	
SV Limiter Lower Limit Value	SV_L	0.0	Measuring range lower limit value–Measuring range higher limit value-1	•
SV Limiter Higher Limit Value	SV_H	1370.0	SV limiter lower limit value +1–Measuring range higher limit value	•
Auto-tuning Point	At_P	0.0	±10000 digit	
Time Unit	tunCt	HM	HM/MS	
Power Failure Compensation	Pw_on	RESEt	RESET/CONT	
No. of Pattern Used	Ptn	9	1–9	
Hysteresis Mode	dFMD	cEnt	CENT/SVOF/SVON	
Bar 1 Display Mode	bAr 1M	out 1	OUT1/OUT2/DEV/STEP/PTN/ECNT	
Bar 1 Scaling	bAr 1S	10.0	0.1–100.0%	
Bar 2 Display Mode	bAr 2M	out 2	OUT1/OUT2/DEV/STEP/PTN/ECNT	
Bar 2 Scaling	bAr 2S	10.0	0.1–100.0%	
Sampling Cycle	S_cM	100	50, 100, 200, 500 min.	
Parameter Initialization	PcncT	oFF	OFF/ON	
Parameter Read	PREAd	oFF	OFF/SET1/SET2	
Parameter Save	PSAVE	oFF	OFF/SET1/SET2	
Liquid Cristal Backlight Brightness	bAlk_L	80	5–100%	
EV Output on Reset	RSEtEV	oFF	OFF/ON	
Program End Signal	PESEtM	1	1–100 min.	
FIX Switching at Program End	PEFcx	oFF	OFF/ON	



25 Specifications

25 Specifications

25-1 Display

- Digital Display: Measured value (PV) 11 segment LCD Red 5 digits
Set value (SV) 11 segment LCD Green 5 digits
PTN No. 11 segment LCD Green 1 digit
STP No. 11 segment LCD Green 2 digits + 2 segments

	11segment character height (mm)			
	PV	SV	PTN	STEP
SRP33	20	12	10	10
SRP34	9	7	7	7

- Bar Display: White/19 dot x 2 step (white)
OUT1, OUT2, DEV (deviation), time rate within STEP
Assignable to rate of No. of executions
Bar Scaling during DEV is set to Measuring range 0.1–100.0%

Bar scaling explanation

Example: Bar scaling at measuring range 100°C = 10.0% deviation range

■ □ □ □ □ □ □ □ □ □ □ ■

-10
0
+10

Example: Bar scaling at measuring range 200°C = 10.0% deviation range

■ □ □ □ □ □ □ □ □ □ □ ■

-20
0
+20

- Status display: Action state (status) display of 28 items
Lighting or blinking during status validity

RUN	Green	Lights during action execution, lights out during reset status, blinks during MAN
HLD	Green	Lights during program run temporary stop, blinks during program temporary stop due to input abnormality
FIX	Green	Lights during FIX (constant value control) Mode, lights out during PROG Mode
AT	Green	Blinks during auto-tuning execution, lights during auto-tuning standby
EXT	Green	Lights during external pattern No. switch DI specification, lights out during external pattern No. key specification
GUA	Green	Lights during guarantee soak action execution
REM	Green	Lights during remote SV execution
(Up)	Green	Lights during up-step execution while in program action
(Flat)	Green	Lights during flat step execution while in program action
(Down)	Green	Lights during down-step execution while in program action
PTN	White	Lights during Pattern No. display
STEP	White	Lights during Step No. display
SV-No.	White	Lights during display of SV-No. in execution
PID-No.	White	Lights during display of PID-No. in execution
°C	White	Lights when displayed unit is Celsius
°F	White	Lights when displayed unit is Fahrenheit
K	White	Lights when displayed unit is Kelvin
EV1-EV4	Orange	Lights during Event Output
DO1-DO6	Orange	Lights during external control digital output
	Orange	Lights during keylock, parameter cannot be changed

- Display resolution: 0.0001, 0.001, 0.01, 0.1, 1 (differs according to input range)
- Display accuracy: Measuring range ± (0.1% + 1 digit) (Refer to Separate Measuring Range Code Table)

TC input	± (0.1% FS + 1°C)
Pt input	± (0.1% FS + 0.1°C)
mV, V input	± (0.1% FS + 1digit)
mA input	± (0.1% FS + 1digit) Depends on accuracy of external resistor 250Ω

- Display cycle: According to sampling cycle (50 ms, 100 ms, 200 ms, 500 ms)



25-2 Setting

- Local Setting: Front panel key switch operation
 (RUN), PIN, STEP, , , , ENT
- Communication setting: Same level as local setting (latter operation is prioritized)
- Remote setting: Has priority over external analog signal SV setting and communication setting (Available only during FIX Mode)
- DI setting: Level action function has priority over local setting and communication setting
Edge action function is the same level (latter operation is prioritized)
- PV limiter: Settable within measuring range-10~110% (scaleover point)
* P value is calculated based on measuring range and therefore is not affected by PV limiter
- SV limiter: Settable within measuring range and PV limiter
- Setting lock: OFF and keylock possible on level 1 to 3
- Parameter initialization: Initialization of user parameter can be changed by end-user.
- Parameter bank: 3 classes (Specify which bank to use among the 3 classes of parameter bank)
* During user parameter initialization, only the bank in use is initialized.
* Copy to bank is possible using copy function.

25-3 Input

Input Common Specifications

- Input range: Full multi-input, Multi-range input
- Scaling: (Voltage, current) possible during linear input -19999~32000 within span 10~52000
- Decimal point position: Can be set from none, 1/10, 1/100, 1/1000, 1/10000
(With or without a decimal point, it is selectable for TC and PT.)
- Sampling Cycle: 50 ms, 100 ms, 200 ms, 500 ms
- PV limiter: Settable within the measuring range -10%~110%
- Unit: °C, °F, K switch through front key switch and communication
- PV Bias: ±10000 digit
- PV ratio: 0.500~1.500 times input value
- PV Filter: OFF, 1~100 sec.
- PV input operation: Square root extraction (only linear input, input low cut 0.0~5.0%FS)
- Multi-bias function: 10-segment Linear Approximation (only linear input) 11 point
PV-MBIAS (PV) 11 point, PV-MBIAS (SV) 11 point
- Scaleover display: Sc_LL Sc_HH burnout and others
- Isolation: Non-insulated from System DI, CT and REM, but insulated from other input/output.

Thermocouple input (TC)

- Input type: B, R, S, K, E, J, T, N, PL II, PR40-20, C(WRe5-26) [L, U (DIN43710)]
Refer to Measuring Range Code Table
- Display range: Within PV limiter (Provided minimum temperature does not fall below -273.15°C)
With or without a decimal point, it is selectable.
- Input resistor: Approx. 500kΩ
- Cold Junction Temperature Compensation: Selection of internal Cold Junction Temperature Compensation/external Cold Junction Temperature Compensation
- Internal Cold Junction Temperature Compensation accuracy: ±1°C (18~28°C range)
- Burnout function: Only upscale
- Lead wire tolerable resistance range: Below 100Ω/1 wire

RTD input (RTD)

- Input type: Pt100/JPt100 3-wire type Refer to Measuring Range Code Table.
- Display range: Within PV Limiter (Provided minimum temperature does not fall below -240.0°C)
decimal point removable
- Lead wire tolerable resistance range: Below 10Ω/1 wire
- Measured current: Approx. 1 mA

Voltage input (mV)

- Input type: -100~100 mV Refer to Measuring Range Code Table.



25 Specifications

- Display: Programming Scaling (Within PV limiter, round off to the second place from the lowest displayed place)
- Input resistance: approx. 500kΩ

Voltage input (V)

- Input type: -10–10 V (1/100 attenuator) Refer to Measuring Range Code Table.
- Display: Programming Scaling (Within PV limiter, round off to the second place from the lowest displayed place)
- Input resistance: approx. 500kΩ

Current input (mA)

- Input type: 0–20 mA/4–20 mA Refer to Measuring Range Code Table.
- Display: Programming Scaling (Within PV limiter, round off to the second place from the lowest displayed place)
- Receiver resistance: External resistance (250Ω) necessary

25-4 Control Mode

Expert PID Control with auto-tuning function

- No. of SV: SV1–9
- No. of PID: 9 class
- Zone PID: 9 Zone The object of OFF, SV, PV, and Zone PID has SV, PV that cannot be set singly.
- Hysteresis: 0–10000 digit
- Proportional Band Width: OFF, 0.1 – 999.9% (ON-OFF Action when OFF)
- Integral Time: OFF, 1–6000 sec. (P or PD Action when OFF)
- Derivative Time: OFF, 1–3600 sec. (P or PI Action when OFF)
- Manual Reset: -50.0–50.0% (valid when I = OFF)
- Dead Band (OUT2): -19999–30000 digit
- Hysteresis Mode: Select from the 3 modes below
CENT mode, SVOF mode, SVON mode
- ON-OFF hysteresis: 1–9999 digit (Valid when P = OFF)
- Proportional Cycle: 1–3000 sec. 1 sec step (during contact or SSR drive voltage output)
- Control output characteristics: Reverse/direct selectable
- Output change rate limiter: OFF, 0.1–100.0 %/sec.
- Manual output: 0.0–00.0%, 0.1% step
- AT point offset: ±10000 digit
- Output updating cycle: Selection from 50 ms, 100 ms, 200 ms, 500 ms (according to sampling cycle)
- Manual control: Balanceless, bumpless action
(Switch through front panel key switch or external control input (DI))
Output setting range 0.0–100.0%
Setting resolution 0.1%



25-5 Control Output 1

- Contact (Y): Contact (1a) 240 V AC 2.5 A: resistive load/1 A: inductive load
- SSR drive voltage (P): 12 V \pm 1.5 V DC (Maximum load current 20 mA)
- Current (I): 4–20 mA DC (Maximum load resistance 600 Ω)
- Voltage (V): 0–10 V DC (Maximum load current 2 mA)
- Output accuracy: \pm 0.5%FS (5–100% output/within accuracy maintaining temperature range)
- Output resolution: Approx. 1/50000 (during current/voltage output)
- Isolation: I, P, and V of AO and Control Output 1, 2 are uninsulated, but are insulated from other input and output

25-6 Control Output 2 (Option)

- Contact (Y): Contact (1a) 240 V AC 2.5 A: resistive load/1 A: inductive load
- SSR drive voltage (P): 12 V \pm 1.5 V DC (Maximum load current 20 mA)
- Current (I): 4–20 mA DC (Maximum load resistance 600 Ω)
- Voltage (V): 0–10V DC (Maximum load current 2 mA)
- Output accuracy: \pm 0.5%FS (5–100% output/within accuracy maintaining temperature range)
- Output resolution: Approx. 1/50000 (during current/voltage output)
- Selection limit: Exclusive selection with EV4
- Isolation: I, P, and V of AO and Control Output1, 2 are uninsulated, but are insulated from other input and output

25-7 Event Output

- No. of Output: Standard 3 points (EV1–EV3) additional (option) 1 point (EV4)
- Constant value (EV1–EV3): Contact (1a) 240 V AC 1 A: resistive load (Common common)
- Function: (EV4) Contact (1a) 240 V AC 2.5 A: resistive load
- Hd: Higher limit deviation value action
- Ld: Lower limit deviation value action
- od: Outside higher and lower limit deviation action
- id: Within higher and lower limit deviation action
- HA: Higher limit absolute value action
- LA: Lower limit absolute value action
- OUT1H: Output 1 higher limit
- OUT1L: Output 1 lower limit
- OUT2H: Output 2 higher limit
- OUT2L: Output 2 lower limit
- TS1: Time signal 1
- TS2: Time signal 2
- TS3: Time signal 3
- TS4: Time signal 4
- TS5: Time signal 5
- TS6: Time signal 6
- TS7: Time signal 7
- TS8: Time signal 8
- RUN: Run signal (Control execution signal)
- HLD: Program hold signal
- GUA: Guarantee soak signal
- STEP: Step signal
- PTN_E: Pattern end signal
- PRG_E: Program end signal
- UP_SL: Up slope signal
- DW_SL: Down slope signal
- FIX: Fixed value control mode
- AT: Auto-tuning
- REM: Remote SV
- SO: During scaleover



- PV SO: During PV scaleover
- REM SO: During REM scaleover
- ct1bA: heater1 break alarm (CT1)
- ct1LA: heater1 loop alarm (CT1)
- ct2bA: heater2 break alarm (CT2)
- ct2LA: heater2 loop alarm (CT2)
- ct_bA: heater break alarm (CT1,CT2 OR(logical disjunction))
- ct_LA: heater loop alarm (CT1,CT2 OR(logical disjunction))
- Setting range
 - Absolute value: Within measuring range and PV limiter (both upper and lower limit)
 - Deviation: -19999–30000 digit (both upper and lower limit)
 - Higher and lower limit deviation: 0–30000 digit (both inside and outside)
- Action: ON-OFF action
- Hysteresis: 1–9999 digit
- Action delay time: OFF, 1–9999 sec.
- Standby action: Separate setting (separate output) Select from any of 4 types below (When selecting DEV, PV, SV)
 - 1) None
 - 2) Standby 1 (When starting power, when RESET ON → OFF)
 - 3) Standby 2 (When starting power, when RESET ON → OFF, when execution SV is changed)
 - 4) Standby 3 (Does not output when there is input abnormality)
- Latching: Selection from Yes/No
- Output characteristics: Selection from NO/NC
- Output renewal cycle: According to sampling cycle (50 ms, 100 ms, 200 ms, 500 ms)
- Isolation: Insulated from all input and output (Uninsulated within EV1–3)
- Selection limit: EV4 is an exclusive selection with respect to Control Output 2.

25-8 External Control Output (DO) (Option)

- No. of output: 1st Option 3 points (DO1–DO3)
2nd Option 3 points (DO4–DO6)
- Output type: Darlington open collector output
- Rating: 24 V DC/50 mA maximum ON voltage below 1.5 V
- Function/Setting range
 - /Action/Hysteresis
 - /Action delay time
 - /Standby action
 - /Output updating cycle: Same as EV1–4
- Isolation: Insulated from all input and output (Uninsulated within DO1–6)
- Selection limit: DO4–6 is an exclusive selection with respect to CT input and remote setting input.

25-9 External Control Input (DI)

- No. of input: Standard 2 points (DI1–2) + option 5 points (DI3–7) addition possible
- Input type: Level input, Edge input
- Input fixed rate: Voltage 5 V DC (2.5 mA/1 input)
- Input action: Non-voltage contact or open collector
- Input holding time: According to sampling cycle
- Function:

non	No assignment	
Run1	Switch Run/Reset	Level
Run2	Switch Run//Reset	Edge
RSt	Program forced reset	Level
HLd	Hold processing	Level
AdV	Advance processing	Edge
FIX	FIX Mode	Level
MAN	Manual output	Level
L_rS	Latching total release	Edge



	KLock	keylock 3	Level
	Ptn3	Start pattern No. 3 bit	Level
	FSVNo	SV No. 3 bit	Level
	Act1	Output 1 output characteristics	Level
	Act2	Output 2 output characteristics	Level
	REM	Remote SV switch	Level
• Isolation:	Uninsulated from system, PV, CT and REM but insulated with respect to other input and output		

25-10 Analog Output (AO) (Option)

• No. of output:	1 point (option)
• Function:	PV, SV, DEV, OUT1, OUT2
• Output fixed rate:	0–10 mV DC/Output resistance 10Ω 0–10 V DC/Load Current below 2 mA 4– 20 mA DC/Load resistance below 300Ω
• Output accuracy:	±0.1%FS (with respect to display value)
• Output resolution:	Approx. 1/45000
• Output renewal cycle:	50 ms, 100 ms, 200 ms, 500 ms (according to sampling cycle)
• Output Scaling:	PV, SV Within measuring range Within DEV ±100.0% [PV-SV] Within OUT1, OUT2 0.0–100.0%
• Reverse Scaling:	Possible
• Output Limiter:	Lower limit 0.0–99.9% Higher limit 0.1–100.0% Lower limit < Higher limit
• Isolation:	Uninsulated from control output P, I, V but insulated with respect to other input and output

25-11 Remote setting input (REM) (Option)

• No. of input:	1 point (option)
• Function:	Analog SV setting
• Setting signal:	1–5 V input resistance approx. 500kΩ 0–10 V input resistance approx. 500kΩ 4– 20 mA reception resistance 250Ω
• Input accuracy:	±0.1%FS
• Sampling cycle:	50 ms, 100 ms, 200 ms, 500 ms (according to PV sampling cycle)
• Bias:	±10000 digit
• Scaling:	Possible within setting range (reverse scaling possible)
• Filter:	OFF, 1–300 sec.
• Ratio:	0.001–30.000
• Low-cut:	Range 0.0–5.0%FS
• Direct tracking:	Yes
• Isolation:	Uninsulated from system, PV, DI and CT but insulated with respect to other input and output
• Limitations:	Available only during FIX Mode Exclusive selection with respect to DO4–6, CR input, feedback potentiometer input



25-12 Heater Break Alarm (Option)

- CT input: 2 points (option) Common common
- Alarm action: During heater break detection when control output is ON, Alarm ON
(Heater current when ON \leq set current)
During heater loop abnormality detection when control output is OFF, Alarm ON
(Heater current when OFF \geq set current)
- Hysteresis: 0.2 A
- Current detection: Through attached CT (exclusive CT attached/single phase or 3-phase)
- Detection source selection: Select either OUT1 or OUT2 (Provided that output is either Y or P)
- Sampling time: According to sampling cycle
- Minimum action confirmation time: Above 0.2 sec. (200 msec.) (both when Control Output is ON and OFF)
- Current display: 0.0–55.0 A
- Display accuracy: 3%FS (Sine wave 50Hz)
- Output destination: Assigned to EV and DO output
- Isolation: Uninsulated with respect to system, other CT input, PV, DI and REM, and insulated with respect to other input and output
- Limitations: Addable only when either Control Output 1 or Control Output 2 is Y or P
Exclusive selection with respect to DO4–6 and feedback potentiometer input, as well as remote setting input

25-13 Communication Function (Option)

- No. of port: 1 point (option)
- Communication type: RS-232C, RS-485
- Communication system: RS-232C 3-line half duplex system
RS-485 2-line half duplex multidrop (bus) system
- Synchronization system: Start-stop synchronization system
- Communication distance: RS-232C/Max length 15 m RS-485/Max length 500 m (Differs according to connection conditions)
- Communication rate: 2400, 4800, 9600, 19200, 38400 bps
- Communication address: 1–255
- Communication memory mode: EEP/RAM/r_E
- Communication Delay time: 1–500 ms step 1 ms
- No. of communication unit: RS-232C 1 unit/RS-485, possible up to 255 units (depends on connection conditions)
* Node for connecting 255 units of RS-485 should all be the SRP30 series.
- Terminal resistor: RS-232C/not used, RS-485/120 Ω attached
- Master function: Yes (SV value RUN/RST)
- Isolation: All input and output are insulated.

Shimaden standard protocol

ASCII code:	Data length	7, 8 bit
	Parity	even number, odd number, none
	Stop bit	1, 2 bit
	Control code	STX_ETX_CR/STX_ETX_CRLF/@_:_CR
	Communication BCC	Add/Add two's cmp/XOR/None

MODBUS ASCII mode

ASCII mode:	Data length	7 bit fixed
	Parity	Even number, odd number, none
	Stop bit	1, 2 bit
	Control code	_CRLF
	Error check	LRC check



Function code 03H data read
06H supports data write

MODBUS RTU Mode

Binary Mode:

Data length 8 bit fixed
Parity Even number, odd number, none
Stop bit 1, 2 bit
Control code none
Error check CRC check
Function code 03H data read
06H supports data write

25-14 Front Panel Loader Communication

- Interface: USB 2.0 Micro B connector (standard)
 - Compatible OS: Windows 7, Windows 10
 - Synchronization system: Start-stop synchronization system
 - Communication rate: 38400 bps
 - Data format: 8 bit, Parity none, 1 Stop bit fixed
 - Communication BCC: Add fixed
 - Communication protocol: Shimaden Standard Protocol
 - Communication code: ASCII Code
 - Control code: STX_ETX_CR
- * To connect to PC, micro USB cable (QCUS001) (A male connector ⇔ micro B male connector) is necessary (sold separately).

25-15 Program Function

- Setting system: Front panel key switch or communication
- No. of pattern: Maximum 9 Patterns
- No. of step: Maximum 180 Steps (Initial value 10 step)
- Step time: 0 min. 0 sec.–300 min. 0 sec. or 0 hr. 0 min.–300 hrs. 0 min.
- No. of pattern executions: Maximum 30000 repetition possible
- No. of step loop: Maximum 30000 repetition possible
- Pattern link setting: Maximum 10 patterns connectable
Maximum 30000 times executable
- Link execution setting: Maximum 30000 repetition possible
- Time accuracy: ± (Set time x 0.02% + 0.1 sec.)
- Step setting items: SV, Step time, PID No.
- Power failure compensation: Yes/No selectable
- SV setting: Same as measuring range
- Time setting: 0–300 hrs. 0min./step or 0–300 min. 0 sec./step
- Advance function: Skip step currently executed and proceed to next step
- Hold Function: Temporary stop of time progress
- Time signal setting: No. of registration: Maximum 8 points, assigned to Event Output and DO
(Per step) Time: 0–300 hrs. 0 min./step or 0–300 min. 0 sec./step
resolution: 1 min. or 1 sec.
- Guarantee soak: Zone setting range: 0–10000 digit
Time setting range: 0–300 hrs. 0 min./step or 0–300 min. 0 sec./step



25-16 General Specifications

- Data storage: By non-volatile memory (EEPROM)
- Operating ambient temperature/humidity range: below -10–55°C/90% RH (No dew condensation)
Derating from 50°C
- Storage temperature: -20–65°C
- Overvoltage Category: II
- Pollution degree: 2 (IEC60664)
- Supply, voltage: 100–240 V AC \pm 10% (50/60 Hz)
- Power consumption: SRP33: Maximum 18 VA
SRP34: Maximum 15 VA
- Input noise removal ratio: Normal Mode: Above 50 dB (50/60 Hz)
Common Mode: Above 120 dB (50/60 Hz)
- Applicable Standard: Safety: IEC61010-1 and EN610101-1
IEC61010-2-030 and EN61010-2-030
EMC: EN61326-1
- Power supply short-break time: Within 50 ms, normal action continuation (When 200 V AC)
- Insulation resistance: Input-output terminal and power terminal interval: Above 500 V DC 20M Ω
Power terminal and grounding terminal interval: Above 500 V DC 20M Ω
- Dielectric strength: Input-output terminal and terminal interval: 3000 V AC 1 min. (Faradic current 5 mA)
Power terminal and grounding terminal interval: 1500V AC 1 min. (Faradic current 5 mA)
- Construction: Front panel Dust-proof and Drip-proof front panel (IP55 equivalent)
- Material of case: Resin mold (UL94V-1 equivalent)
- External dimensions: SRP33: H96 x W96 x D111 mm within panel 100 mm
SRP34: H96 x W48 x D111 mm within panel 100 mm
- Mounting: Panel flush mounting (Installed with metal fitting)
- Applicable panel thickness: 1–8 mm
- Panel cutout: SRP33: H92 x W92 mm
SRP34: H92 x W45 mm
- Weight: SRP33: approx. 410 g
SRP34: approx. 280 g

* With regard to the technical details of products, please contact your nearer Shimaden dealer.

The contents of this manual are subject to change without notice.

Temperature and Humidity Control Specialists
SHIMADEN CO., LTD.

Head Office: 2-30-10 Kitamachi, Nerima-ku, Tokyo 179-0081 Japan

Phone: +81-3-3931-7891 Fax: +81-3-3931-3089

E-MAIL: exp-dept@shimaden.co.jp URL: <https://www.shimaden.co.jp>

Printed in Japan