

**SIEMENS**

**7**<sub>435</sub>



## Burner Controls

**LGB...**

**Burner controls for the supervision, startup and control of 1- or 2-stage gas burners. As well as for gas burners / oil burners of small to medium capacity (typically up to 350 kW), with or without fan in intermittent operation.**

**The LGB and this Data Sheet are intended for use by OEMs which integrate the burner controls in their products!**

### Use, features

#### Use

The LGB burner controls are used for the startup and supervision of 1- or 2-stage gas or gas / oil burners in intermittent operation.  
Depending on the type of burner control used, the flame is supervised either by an ionization probe, a blue-flame detector QRC1 for forced draft gas / oil burners, or a UV detector QRA (with auxiliary unit AGQ1.xA27).  
Using the appropriate adapter, the LGB can replace the predecessor types LFI7 and LFM1 in terms of function (refer to *Replacement types* under *Ordering*).

- Applications in accordance with EN 676: Automatic forced draft burners for liquid fuels
- Type-tested and approved in accordance with EN 298:1994-02 or EN 298:1993

**Use, features (continued)**

General features	<ul style="list-style-type: none"> <li>• Undervoltage detection</li> <li>• Air pressure supervision with function check of the air pressure switch during startup and operation</li> <li>• Electrical remote reset facility</li> </ul>
Undervoltage detection	In the event that the mains voltage drops below about AC 165 V, an electronic circuit ensures that the gas burner control will prevent burner startup or – without releasing fuel – lockout will be initiated.
Special features	LGB41 for use with atmospheric gas burners.



**Note!**  
 Do not use for new designs.



**Note!**  
 The following burner controls can be used for new designs:

- LME1
- LME2
- LME3
- LME4

**Warning notes**



**To avoid injury to persons, damage to property or the environment, the following warning notes must be observed!**

**Do not to open, interfere with or modify the unit!**

- All activities (mounting, installation and service work, etc.) must be performed by qualified staff
- Before performing any wiring changes in the connection area of the LGB, completely isolate the plant from the mains supply (all-polar disconnection). Ensure that the plant cannot be inadvertently switched on again and that it is indeed dead. If not disconnected, there is a risk of electric shock hazard
- Ensure protection against electric shock hazard by providing adequate protection for the burner control's connection terminals. If not observed, there will be a risk of electric shock
- Each time work has been carried out (mounting, installation, service work, etc.), check to ensure that wiring is in an orderly state and make the safety checks as described in *Commissioning notes*. If not observed, the safety functions are no longer ensured and there will be a risk of electric shock
- Press the lockout reset button only manually (apply a force of no more than 10 N), without using any tools or pointed objects. If not observed, the safety functions are no longer ensured and there will be a risk of electric shock
- Fall or shock can adversely affect the safety functions. Such units must not be put into operation, even if they do not exhibit any damage. If not observed, the safety functions are no longer ensured and there will be a risk of electric shock



**Attention!**  
**Earth the burner in compliance with the relevant regulations; earthing the boiler alone does not suffice!**

**Mounting notes**

Ensure that the relevant national safety regulations are complied with.

**Installation notes**

- Always run the ignition cables separate from the unit and other cables while observing the greatest possible distance
- Make absolutely certain that live and neutral conductors are correctly connected to terminals 1 and 2 of the burner control; otherwise, no flame signal will be generated
- Install switches, fuses, earthing, etc., in compliance with local regulations
- Ensure that the maximum permissible current load for the connecting terminals is not exceeded, refer to *Technical data*
- The connection diagrams show the burner controls with earthed neutral conductor. In networks with nonearthed neutral conductor and ionization current supervision, terminal 2 must be connected to the earth conductor via an RC unit (type reference ARC 4 668 9066 0). It must be made certain that local regulations are complied with (e.g. protection against electric shock hazard) since AC 230 V / 50 Hz mains voltage produces peak leakage currents of 2.7 mA
- Do not feed external mains voltage to the control outputs of the unit. When testing the devices controlled by the burner control (fuel valves, etc.), the burner control must not be connected
- To isolate the burner control from the mains supply, use an all-polar switch with a contact gap of at least 3 mm
- Secure the earthing lug in the base with a metric screw and a lockwasher
- Switches, fuses, earthing, etc., must be in compliance with local regulations; primary fuse max. 6.3 A, slow
- Connect the gas pressure switch and other controller (whose contacts must be closed from startup to controlled shutdown) in series with control thermostat or pressurestat (R) and limit thermostat or temperature limiter (W)
- In the case of burners with no fan, the AGK25 must be connected to terminal 3 as a burden, or else the burner cannot reliably start
- For safety reasons, feed the neutral conductor to the neutral distributor in the plug-in base, or to terminal 2. Connect the burner components (fan, ignition transformer and fuel valves) as represented in the figure 7435a14, to the neutral distributor as shown below. The connection between neutral conductor and terminal 2 is prewired in the base

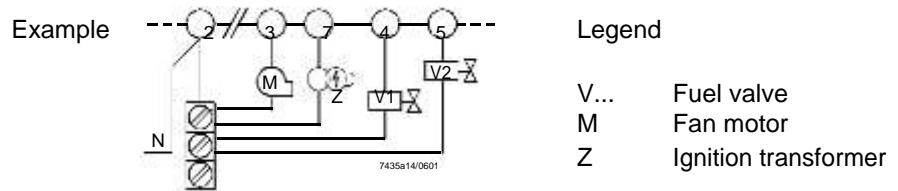

Correct wiring of neutral conductors!

**Electrical connection of flame detectors**

It is important to achieve practically disturbance- and loss-free signal transmission:

- Never run detector cables together with other cables
  - Line capacitance reduces the magnitude of the flame signal
  - Use a separate cable
- Observe the permissible length of the flame detector cables (refer to *Technical data - Flame supervision* and Data sheet/ Flame detector QRA (N7712) or QRC (N7716)
- The ionization probe and the ignition electrode are not protected against electric shock hazard
- Locate the high-voltage ignition electrode and the ionization probe such that the ignition spark cannot arc over to the ionization probe (risk of electrical overloads) and that it cannot adversely affect the supervision of ionization
- With both ionization current and UV supervision, the cable length for flame detection must not exceed 20 m
- Insulation resistance
  - the insulation resistance must be >50 MΩ between ionization probe and ground
  - Soiled detector holders reduce the insulation resistance, thus supporting creepage currents



**Note!**

Recommendation:

Use high-quality detector cables with heat-resistant insulation and an ionization probe with ceramic insulation.

- The burner (as the counter-electrode) must be correctly earthed, or else no ionization current will flow
- Only for atmospheric burners:  
 Since the burner bars form the earthed counter-electrode, the burner must be adjusted so that the flame is hot and stable and in firm contact with the burner bars. With pulsating flames or yellow-burning flames resulting from lack of air, a very low or even no ionization current is generated so that the burner enters malfunction

**Commissioning notes**

When commissioning the plant for the first time or when doing maintenance work, make the following safety checks:

	<b>Safety check to be carried out</b>	<b>Anticipated response</b>
a)	Burner startup with previously interrupted line to the ionization probe and flame detector darkened in the case of QRA or QRC1	Lockout at the end of safety time (TSA)
b)	Burner operation with simulated loss of flame. For that purpose, cut off the gas supply (e.g. disconnect the fuel valve while ensuring protection against electric shock hazard)	Immediate lockout
c)	Burner operation with simulated air pressure failure (not with atmospheric burners)	Immediate lockout

## Standards and certificates



### Applied directives:

- Directive for gas-fired appliances 2009/142/EC
- Electromagnetic compatibility EMC (immunity) \*) 2004/108/EC

\*) The compliance with EMC emission requirements must be checked after the burner control is installed in equipment

Compliance with the regulations of the applied directives is verified by the adherence to the following standards / regulations:

- Automatic burner control systems for oil burners DIN EN 230:1991
- Automatic burner control systems for burners and appliances burning gaseous or liquid fuels DIN EN 298:1994
- Automatic electrical controls for household and similar use DIN EN 60730-2-5:1995  
Part 2-5:  
Particular requirements for automatic electrical burner control systems

**The relevant valid edition of the standards can be found in the declaration of conformity!**



EAC Conformity mark (Eurasian Conformity mark)



ISO 9001:2008  
ISO 14001:2004  
OHSAS 18001:2007



China RoHS  
Hazardous substances table:  
<http://www.siemens.com/download?A6V10883536>



### Note on **DIN EN 60335-2-102**

Household and similar electrical appliances - Safety - Part 2-102:  
Particular requirements for gas, oil and solid-fuel burning appliances having electrical connections.

The electrical connections of the LGB and the AGK11 comply with the requirements of EN 60335-2-102.

Identification code to EN 298

- LGB21 / LGB22 **F T L L X N** with 2-stage operation -





LGB32 **F M L L X N** with 2-stage operation - LGB41 **A B L L**

**X N** with 2-stage operation

(Fuel valve (BV1) + fuel valve (BV2) or ignition gas valve (ZV1) + fuel valve (BV2)

**A M L L X N** with 1-stage operation

**Standards and certificates (cont'd)**

				
LGB21.130A17	●	●	---	---
LGB21.130A27	●	●	●	●
LGB21.230A27	●	●	●	---
LGB21.330A27	●	●	●	---
LGB21.350A17	●	●	---	---
LGB21.350A27	●	●	●	●
LGB21.550A27	●	●	●	●
LGB22.130A27	●	●	●	●
LGB22.230B27	●	●	●	---
LGB22.330A17	●	●	---	---
LGB22.330A27	●	●	●	●
LGB22.330A270	●	●	●	---
LGB32.130A27	●	●	●	●
LGB32.230A17	●	●	---	---
LGB32.230A27	●	●	●	---
LGB32.330A17	●	●	●	---
LGB32.330A27	●	●	●	---
LGB32.350A17	●	●	●	---
LGB32.350A27	●	●	●	●
LGB41.255A27	●	●	---	●
LGB41.258A17	●	●	---	---
LGB41.258A27	●	●	---	●

**Service notes**

The service adapters may only be used for a short time. They may only be used in supervised operation by qualified staff.

**Life cycle**

Burner controls has a designed lifetime\* of 250,000 burner startup cycles which, under normal operating conditions in heating mode, correspond to approx. 10 years of usage (starting from the production date given on the type field).

This lifetime is based on the endurance tests in the standard EN 298. A summary of the conditions has been published by the European Control Manufacturers Association (Afecon) ([www.afecon.org](http://www.afecon.org)).

The designed lifetime is based on use of the burner controls according to the manufacturer's Data Sheet. After reaching the designed lifetime in terms of the number of burner startup cycles, or the respective time of usage, the burner control is to be replaced by authorized personnel.

\* The designed lifetime is not the warranty time specified in the Terms of Delivery

### Disposal notes

---



The unit contains electrical and electronic components and must not be disposed of together with household waste.  
Local and currently valid legislation must be observed.

### Mechanical design

---

The burner controls are of plug-in design, suitable for installation in any position on burners, in control cabinets or on control panels.

The housing is made of impact-proof, heat-resistant and flame-retarding plastic. It is of plug-in design (measuring 91 x 62 x 63 mm, including the base) and engages audibly in the base.

The color of plastic material of burner controls LGB are executed in black.

The housing accommodates the

- programming mechanism with the synchronous motor
- electronic flame signal amplifier (ionization) with the flame relay and the other switching devices
- lockout reset button with its integrated fault indication lamp

### Type summary

The type references given in the table refer to burner controls with no plug-in base and no accessories. For ordering information on plug-in bases and other accessories, refer to *Accessories, Flame supervision ... and Technical data.*

Flame detector	Article no.	Type reference	Approved in:	tw s app rox.	t1 s min.	TSA s max.	t3n s app rox.	t3 s app rox.	t4 s app rox.	t9 s 6) max.	t10 s min.	t11 s 3) max.	t12 s 3) max.	t20 s app rox.
<b>Burner controls for 2-stage burners without control of actuator</b>														
Ionization probe (ION) or UV detector QRA with AGQ1.xA27	<b>BPZ:LGB21.130A27</b>	<b>LGB21.130A27</b> 4)7)	CH, EU, S, SF	8	7	3	2,4	2	8	---	5	---	---	6
	<b>BPZ:LGB21.230A27</b>	<b>LGB21.230A27</b> 5)	CH, EU, S, SF	8	15	3	2,4	2	8	---	5	---	---	38
	<b>BPZ:LGB21.330A27</b>	<b>LGB21.330A27</b> 5)	CH, EU, H, S, SF	8	30	3	2,4	2	8	---	5	---	---	23
	<b>BPZ:LGB21.350A27</b>	<b>LGB21.350A27</b> 5)7)	CH, EU, H, S, SF	8	30	5	4	2	10	---	5	---	---	21
	<b>BPZ:LGB21.550A27</b>	<b>LGB21.550A27</b> 5)	AUS, CH, EU	8	50	5	4	2	10	---	5	---	---	2
<b>Burner controls for 2-stage burners with control of actuator</b>														
Ionization probe (ION) or UV detector QRA with AGQ1.xA27	<b>BPZ:LGB22.130A27</b>	<b>LGB22.130A27</b> 4)	CH, EU, N, S	9	7	3	2,4	3	8	---	4	12	12	21
	<b>BPZ:LGB22.230B27</b>	<b>LGB22.230B27</b> 5)	CH, EU, N, S, SF	9	20	3	2,4	3	8	---	4	16,5	16,5	2
	<b>BPZ:LGB22.330A27</b>	<b>LGB22.330A27</b> 5)7)	AUS, CH, EU, H, N, S, SF	9	30	3	2,4	3	8	---	4	12	11	2
	<b>BPZ:LGB22.330A270</b>	<b>LGB22.330A270</b> 5)8)	EU	9	30	3	2,4	3	8	---	4	12	11	2
Blue-flame detector QRC1	<b>BPZ:LGB32.130A27</b>	<b>LGB32.130A27</b> 4)1)	CH, EU	9	7	3	2,4	3	8	---	4	12	12	21
	<b>BPZ:LGB32.230A27</b>	<b>LGB32.230A27</b> 5)1)	CH, EU	9	15	3	2,4	3	8	---	4	12	12	2
	<b>BPZ:LGB32.330A27</b>	<b>LGB32.330A27</b> 5)	CH, EU	9	30	3	2,4	3	8	---	4	12	11	2
	<b>BPZ:LGB32.350A27</b>	<b>LGB32.350A27</b> 5)	CH, EU	9	30	5	4,4	1	10	---	4	12	9	2
<b>Burner controls for atmospheric burners</b>														
Ionization probe (ION) or UV detector QRA with AGQ1.xA27	<b>BPZ:LGB41.255A27</b>	<b>LGB41.255A27</b>	EU	18	---	5	4	2	10	5	---	---	---	10
	<b>BPZ:LGB41.258A27</b>	<b>LGB41.258A27</b> 2)5)7)	CH, EU, H, SF	18	---	5	4	2	10	8	---	---	---	10

### Legend

tw	Waiting time
t1	Prepurge time
TSA	Ignition safety time
t3	Preignition time
t3n	Postignition time
t4	Interval between fuel valve (BV1) and fuel valve (BV2) or fuel valve (BV1) and load controller (LR)
t9	2 <sup>nd</sup> safety time
t10	Specified time for air pressure signal
t11	Programmed opening time for actuator (SA)
t12	Programmed closing time for actuator (SA)
t20	Interval up to self-shutdown of programming mechanism

- 1) On request
- 2) For atmospheric burners up to 120 kW
- 3) Maximum running time available for actuator
- 4) Also suited for flash steam generators
- 5) Also suited for stationary direct-fired air heaters
- 6) 2<sup>nd</sup> safety time (t9) + reaction time of flame relay
- 7) Also available for AC 100...110 V; in that case, the last 2 digits read ...17 in place of ...27
- 8) Without internal microfuse; must only be used in connection with external microfuse (max. 6.3 A slow!)



**Service adapter** (must be ordered separately)

---

Service adapter **KF8872**

- For checking the functioning of the burner controls on the burner plant
- Functional test with signal lamps
- Detector resistance measurement with a jack of 4 mm diameter



**Accessories (must be ordered separately)**

---

**Connection accessories  
for small burner controls**

Plug-in base **AGK11...**

To connect the small-capacity burner controls to the burner plant.  
See Data Sheet N7201



Cable holders **AGK66...**

For plug-in base AGK11  
See Data Sheet N7201



Cable holders **AGK65...**

For plug-in base AGK11  
See Data Sheet N7201



**Accessories** (must be ordered separately)

**Flame detectors**

UV flame detectors **QRA2**  
 See Data Sheet N7712



UV flame detectors **QRA10**  
 See Data Sheet N7712



UV flame detectors **QRA4**  
 See Data Sheet N7711



Frontal illumination



Blue-flame detectors **QRC1**  
 See Data Sheet N7716

Lateral illumination:



**Ionization probe**  
 Supplied by customer



**Actuators**

**SQN3** actuator  
 Refer to data sheet N7808



**SQN7** actuator  
 Refer to data sheet N7804







**SQN9** actuator  
 Refer to data sheet N7806



**Accessories** (to be ordered separately) (continued)

**Adapters / replacement types**

No rewiring required

LGB21 with adapter	KF8852		LF17
	KF8880		LFM1 1) LFM1...-F 1)
LGB22 with adapter	KF8853-K		LF17
	KF8880		LFM1 1)
LGB41 with adapter	KF8862		LFM1 1)

1) Designed only for ionization

**Others**

**RC unit ARC 4 668 9066 0**

For the supervision of ionization currents in networks with nonearthened neutral conductor



**PTC resistor (AC 230 V) AGK25**

To burden terminal 3 (mandatory when using burners with no fan motor connected to terminal 3)



**Auxiliary unit for UV supervision**

Can be fitted under the plug-in base (refer to «Dimensions»)

**AGQ1.1A27:** Cable length 500 mm

**AGQ1.2A27:** Cable length 300 mm



**Technical data**

General unit data <b>LGB</b>	Mains voltage	AC 220 V -15% ...AC 240 V +10% (LGB2 / LGB4) AC 230 V -15% / +10% (LGB32!) AC 100 V -15% ...AC 110 V +10%
	Mains frequency	50...60 Hz $\pm$ 6%
	External primary fuse (Si)	Max. 6.3 A (slow)
	Power consumption	Approx. 3 VA
	Mounting position	Optional
	Degree of protection	IP40, when built in, with the exception of the connection area
	Safety class	I (burner control with plug-in base)
	Input current at terminal 12	Max. 5 A Within the permissible voltage range AC 187...264 V or AC 195...253 V
	Perm. cable lengths	Max. 3 m at 100 pF/m line capacitance
	Detector cable laid separately	Max. 20 m (refer to Flame supervision chapter)
	Cable length terminals 8 and 10	20 m at 100 pF/m
	Weight	Approx. 230 g

**Permissible current load at  $\cos\phi \geq 0.6$** 

Terminal 3	Max. 3 A (15 A for max. 0.5 s)
Terminals 4, 5 and 7	Max. 2 A
Terminals 9 and 10	Max. 1 A
Terminal 12	Max. 5 A (at $U_{max}$ . AC 264 V or AC 253 V)

Environmental conditions	<b>Storage</b>	DIN EN 60721-3-1
	Climatic conditions	Class 1K3
	Mechanical conditions	Class 1M2
	Temperature range	-20...+60 °C
	Humidity	<95% r.h.
	<b>Transport</b>	DIN EN 60721-3-2
	Climatic conditions	Class 2K3
	Mechanical conditions	Class 2M2
	Temperature range	-20...+60 °C
	Humidity	<95% r.h.
	<b>Operation</b>	DIN EN 60721-3-3
	Climatic conditions	Class 3K3
	Mechanical conditions	Class 3M2
	Temperature range	-20...+60 °C
	Humidity	<95% r.h.
	Installation altitude	Max. 2,000 m above sea level

**Warning!**

**Condensation, formation of ice and ingress of water are not permitted!**  
**If not observed, the safety functions are no longer ensured and there will be a risk of electric shock.**

**Flame supervision**

Flame supervision with ionization probe

	At mains voltage UN = AC 230 V
Detector voltage across terminals 1 and 2 or ground (AC voltmeter Ri ≥10 MΩ)	≤ UN
Detector current required for reliable operation	Min. 3 μA
Possible detector current in operation	Max. 100 μA

Flame supervision with ionization is accomplished by making use of the conductivity and rectifying effect of the flame.

The DC current that flows in the presence of a flame (ionization current) is largely proportional to the flame quality. This current is measured in the flame signal amplifier.

The amplifier is designed so that it only reacts to the DC current of the flame signal. This ensures that a short-circuit between ionization probe and ground cannot simulate a flame signal (since in that case, AC current would flow).

**Note!**  
 The ignition (ignition spark) can have a negative effect on the ionization current formation during startup.



- To minimize the impact
- the positioning of the ionization probe must be checked and optimized
  - it may be beneficial to replace the electrical connections (phase / neutral) on the primary side of the ignition transformer

A short-circuit between ionization probe and ground initiates a non-alterable lockout.

Ionization current supervision with burner controls operating on AC 110 V

Since the ionization current with burner controls operating on AC 110 V is only about 50% of those operating on AC 230 V, certain applications make it necessary to increase the ionization current with a transformer.

Capacity of transformer: Min. 2 VA  
 Transforming ratio: Approx. 1.1...1.5  
 The primary and secondary windings of the transformer must be galvanically separated.

Connection of transformer

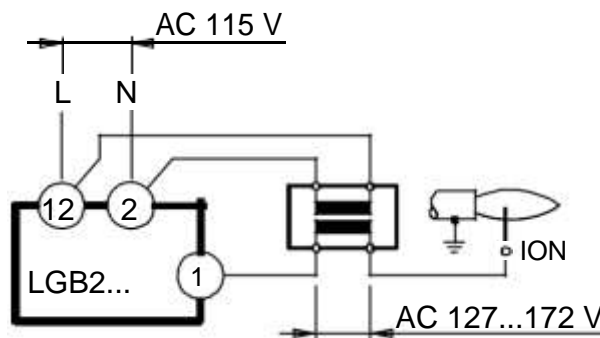

**Flame supervision (cont'd)**

Flame supervision with blue-flame detector QRC1

Perm. detector current during the prepurge time (dark current) (without flame)	Max. 5 $\mu$ A
Detector current required during operation (with flame)	Min. 50 $\mu$ A
Possible detector current in operation (with flame)	Max. 80 $\mu$ A

Measuring circuit for detector current measurement

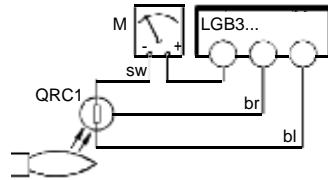

Legend

- sw Black wire
- br Brown wire
- bl Blue wire

The QRC1 has been designed specifically for blue-burning flames. Incidence of light is from the front and laterally. The flame detector is secured by means of a soft plastic plug. 3-core connection (preamplifier integrated in the detector casing). For the different types of flame detectors, engineering notes and technical data, refer to Data Sheet N7716.

Flame supervision with UV detector QRA and AGQ for LGB21 / LGB22 / LGB41

Mains voltage	AC 220 V -15%...AC 240 V +10%
Mains frequency	50...60 Hz $\pm$ 6%
Power consumption	4.5 VA
Degree of protection	IP40
Perm. ambient temperature	
-In operation	-20...+60 °C
-During transport and storage	-40...+70 °C
Perm. length of cable from QRA to AGQ1.xA27 (use separate cable)	Max. 20 m
Mounting position	Optional
Perm. length of connecting cable from AGQ1.xA27 to LGB	Max. 20 m
Weight of AGQ1.xA27	Approx. 140 g

	At mains voltage UN:	
	AC 220 V	AC 240 V
<b>Detector voltage at QRA (with no load)</b>		
Up to the end of specified time (t10) and after controlled shutdown	DC 400 V	DC 400 V
From the beginning of prepurge time (t1)	DC 300 V	DC 300 V
<b>Detector voltage</b>		
<b>Load by DC measuring instrument Ri &gt;10 M<math>\Omega</math></b>		
Up to the end of specified time (t10) and after controlled shutdown	DC 380 V	DC 380 V
From the beginning of prepurge time (t1)	DC 280 V	DC 280 V
<b>DC detector signals with UV detector QRA</b>	<b>Min. required</b>	<b>Max. possible</b>
Measurement on the QRA	200 $\mu$ A	500 $\mu$ A

**Flame supervision (cont'd)**

Flame supervision with UV detector QRA and auxiliary unit AGQ for LGB21 / LGB22 / LGB41

UV detector QRA

Universal flame detector for use with gas and gas / oil burners. Incidence of light from the front and laterally, total length 97 mm. Available with normal or, as QRA2M, with higher sensitivity. Secured with flange and clamp. Also available as a metal encapsulated version in the form of the QRA10 (for details, refer to Data Sheet N7712).

Auxiliary unit AGQ1.xA27

A special UV auxiliary unit AGQ1.xA27 is required in connection with LGB burner controls.

That unit is to be connected to the mains supply via 2 cables, and to the burner control via terminals 1, 2 and 11.

The following option is available to check the through-ignition tendency of aging cells and detecting the UV light:

Operation with a permanent line:

UV test at a higher supply voltage across the UV cell on startup and after controlled shutdown.

Measuring circuit

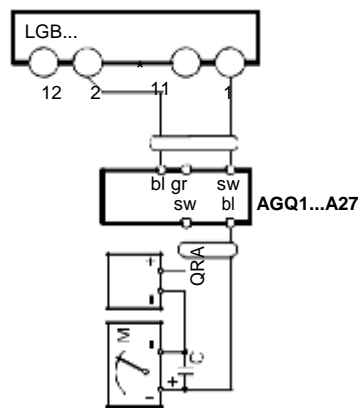

7435a22/0516

Connection diagram

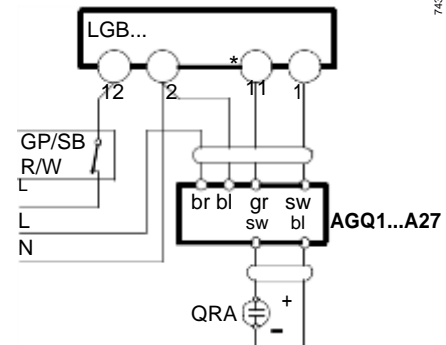

7435a22/0516

Measurement made on the flame detector

**Legend**

- GP Gas pressure switch
- R Temperature or pressure controller
- SB Safety limit thermostat
- W Limit thermostat or pressure switch
- \* With LGB41: Terminal 3
- bl blue
- br brown
- gr grey  
(old: rt = red)
- sw black

## Functions

	<p>The function diagrams show the required or permissible input signals to the control section and to the flame supervision circuit hatched (refer to <i>Connection diagrams</i>). If these input signals are not present, the burner control will stop the startup sequence to trigger lockout where required by safety regulations.</p>
Preconditions for burner startup	<ul style="list-style-type: none"> <li>• Burner control must be reset</li> <li>• The contacts of gas pressure switch (GP), limit thermostat / pressure switch (W), control thermostat / pressurestat ® and safety limit thermostat (SB) must be closed</li> <li>• Fan motor (M) or AGK25 must be connected, Heat request present on terminal 12</li> <li>• Air pressure switch (LP) must be in its no load position</li> <li>• No undervoltage</li> <li>• Flame detector darkened, no extraneous light</li> <li>• No flame signal, optical flame detector (QRA or QRC) darkened, no extraneous light</li> </ul>
Undervoltage detection	<p>LGB burner controls are capable of detecting <b>undervoltages</b>. This means that load relay (AR) will be deenergized if mains voltage drops below AC 160 V (for nominal AC 220...240 V) or AC 75 V (for nominal AC 100...110 V). The burner control will automatically make a restart attempt when the supply voltage returns to a level above AC 160 V and AC 75 V respectively.</p>
Reversed polarity protection	<p>If the connections of live conductor (terminal 12) and neutral conductor (terminal 2) are mixed up, the burner control will initiate lockout at the end of safety time (TSA).</p>
Startup sequence	<p>A – C Startup sequence</p> <p>A <b>Start command</b> (switching on) This command is triggered by control thermostat / pressurestat ®. Terminal 12 receives voltage and the programming mechanism starts running. On completion of waiting time «tw» with the LGB21, or after air damper (SA) has reached the nominal load position (on completion of opening time (t11)) with the LGB22 / LGB32, fan motor (M) will be started.</p> <p>TSA <b>Ignition safety time</b> On completion of safety time (TSA), a flame signal must be present at terminal 1. That flame signal must be continuously available until shutdown occurs, or else flame relay (FR) will be deenergized, resulting in lockout.</p> <p>tw <b>Waiting time</b> During the waiting time, air pressure switch (LP) and flame relay (FR) are tested for correct contact positions.</p> <p>t1 <b>Prepurge time</b> Purging the combustion chamber and the secondary heating surfaces: Required with low-fire air volumes when using the LGB21 and with nominal load air volumes when using the <b>LGB22 / LGB32</b> <i>Type summary</i> and the <i>Function and sequence diagrams</i> show the so-called <b>prepurge time (t1)</b> during which air pressure switch (LP) must indicate that the required air pressure is available. The effective prepurge time (t1) comprises interval end waiting time (tw) through preignition time (t3).</p> <p>t3 <b>Preignition time</b> During preignition time (t3) and up to the end of safety time (TSA), flame relay (FR) is forced to close. On completion of preignition time (t3), the release of fuel is triggered at terminal 4 or at terminal 11 of the LGB41</p>



Functions (cont'd)

- t3n **Postignition time**  
Ignition time during safety time TSA)  
Just before reaching the end of safety time (TSA), ignition transformer (Z) will be switched off.  
This means that postignition time (t3n) is somewhat shorter than safety time (TSA).  
This is necessary in order to give the forcedly closed flame relay (FR) sufficient time to drop out if there is no flame.
- t4 **Interval**  
**LGB21 / LGB41:** Time to the release of the 2<sup>nd</sup> fuel valve (BV2)  
**LGB22 / LGB32:** On completion of interval (t4), the heat source is controlled depending on the load (release of load controller (LR))
- t9 **Second safety time**  
(Only with LGB41)  
For pilot burners with main flame supervision equipped with a pilot gas valve (ZV1).
- t10 **Specified time for air pressure signal**  
On completion of this period of time, the set air pressure must have built up, or else lockout will occur.
- t11 **Programmed opening time for actuator (SA)**  
(Only with LGB22 / LGB32)  
The air damper opens until the nominal load position is reached. Only then will fan motor (M) be switched on.
- t12 **Programmed closing time for actuator (SA)**  
(Only with LGB22 / LGB32)  
During closing time (t12), the air damper travels to the low-fire position.
- B – B' **Interval for establishment of flame**
- C **Burner operating position reached**
- C – D **Burner operation** (generation of heat)  
Nominal output or, in connection with a load controller (LR), low-fire operation.
- D **Shutdown by control thermostat or pressurestat (R)**  
The burner is immediately shut down and the programming mechanism is ready for a new start.

## Functions (cont'd)

Control sequence in the event of fault

If lockout occurs, the outputs for the fuel valves, the burner motor and the ignition equipment are immediately deactivated (<1 second).  
The lockout indication lamp changes to red and voltage is fed to terminal 10 (Alarm) for remote lockout indication.  
This state will also be maintained in the event of power failures.

Cause	Response
After a mains failure or in the event of undervoltage:	New startup with full program sequence on power restoration
Premature flame signal from the start of prepurge time (t1):	Immediate lockout
Contacts of air pressure switch (LP) have welded during waiting time (tw):	Prevention of startup
No air pressure signal:	Lockout on completion of specified time (t10)
Air pressure failure on completion of specified time (t10):	Immediate lockout
Burner does not ignite:	Lockout on completion of safety time (TSA)
Flame is lost during operation:	Immediate lockout

Lockout

After lockout, the LGB will remain locked (lockout cannot be changed).  
This state will also be maintained in the event of mains voltage failure.

Resetting the burner control

Whenever lockout occurs, the burner control can immediately be reset.

**Lockout and control sequence indication**

The position of the programming mechanism can be seen through the viewing window on the front of the unit. In the event of fault, the programming mechanism stops and thus the lockout indicator also. The symbol in the viewing window indicates both the position in the control sequence and the type of fault according to the following legend:

- ◀ No heat request present on terminal 12
- Interval waiting time (tw) or specified time (t10) (LGB21)
- ||| Interval waiting time (tw) or opening time (t11) (LGB22 / LGB32)  
 Interval waiting time (tw), preignition time (t3) or safety time (TSA) (LGB41)
- ▲ Air damper fully open (LGB22 / LGB32)
- P** Lockout due to absence of air pressure signal
- Interval prepurge time (t1), preignition time (t3) and safety time (TSA) (LGB21)
- ◀◀◀ Interval prepurge time (t1), preignition time (t3) (closing time (t12)) (LGB22 / LGB32)
- ▼ Release of fuel
- 1** Lockout since there is no flame signal on completion of the first safety time
- 2** Release of 2<sup>nd</sup> fuel valve (LGB21 / LGB41)  
 Release of load controller (LGB22 / LGB32)
- 3** Lockout since there is no flame signal on completion of the 2<sup>nd</sup> safety time (LGB41)
- Low-fire or high-fire operation (or return to the operating position)

**Connection diagram and control sequence**

**LGB21**

Burner controls for 1- or 2-stage forced draft burners.  
 Air damper control for prepurging with **low-fire air volume**.

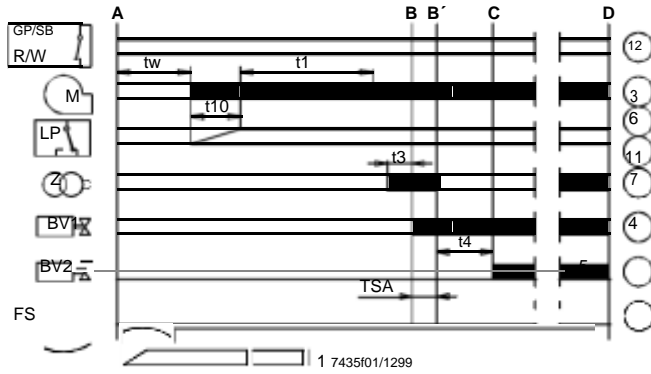

**Application examples**

Control of actuators of 2-stage or 2-stage modulating burners.  
 Prepurging (t1) with low-fire air volume.  
 Same low-fire actuator position (switching cam III) during startup and operation!

For information about actuators (SA):  
 SQN3: Refer to Data Sheet N7808  
 SQN7: Refer to Data Sheet N7804  
 SQN9: Refer to Data Sheet N7806

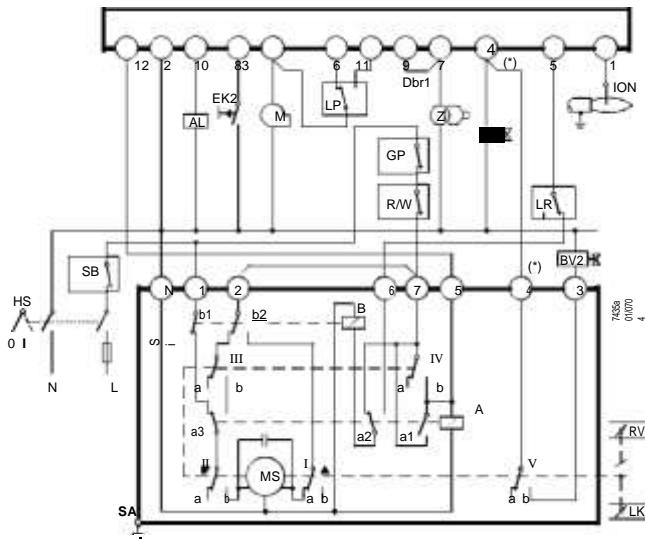

**SQN3...121...**

**\* Note:**

With 2-stage modulating burners (with gas control damper (RV)),  
 fuel valve (BV2) and the dotted connection between terminals (\*)  
 are not required

**Flame supervision**

**LGB21:** With ionization probe or auxiliary unit AGQ1.xA27 for UV detector  
 QRA

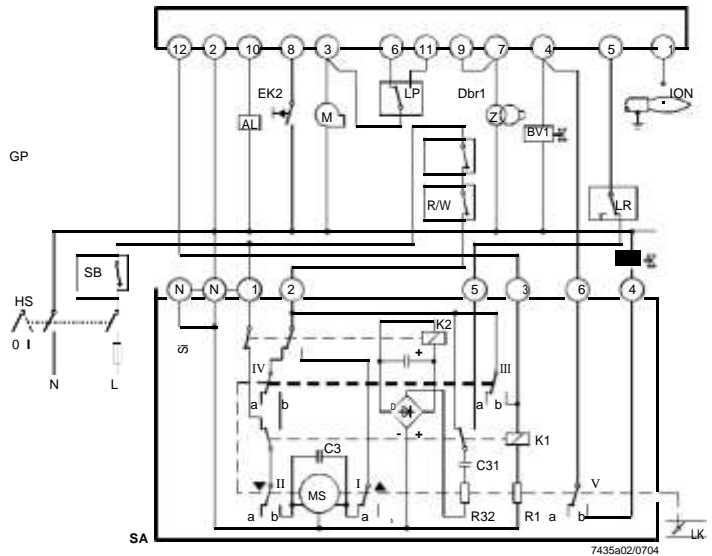
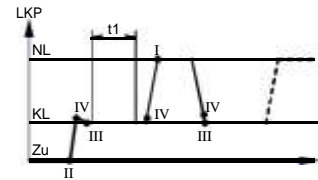
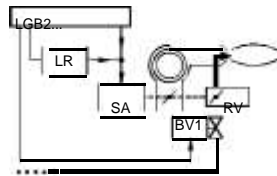
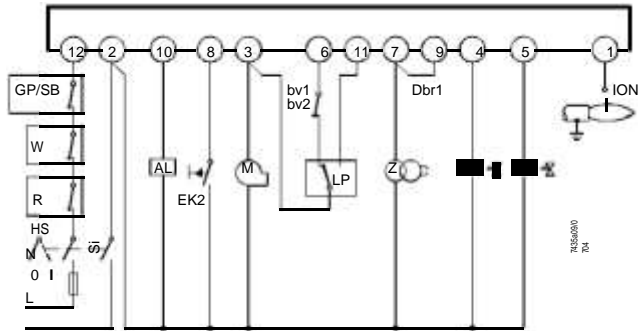

**SQN91.140 / 2-stage control**

**Connection diagram and control sequence (cont'd)**

**LGB21**

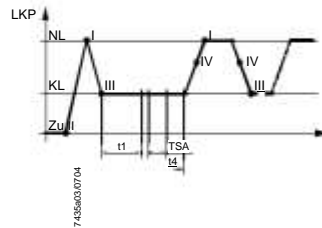
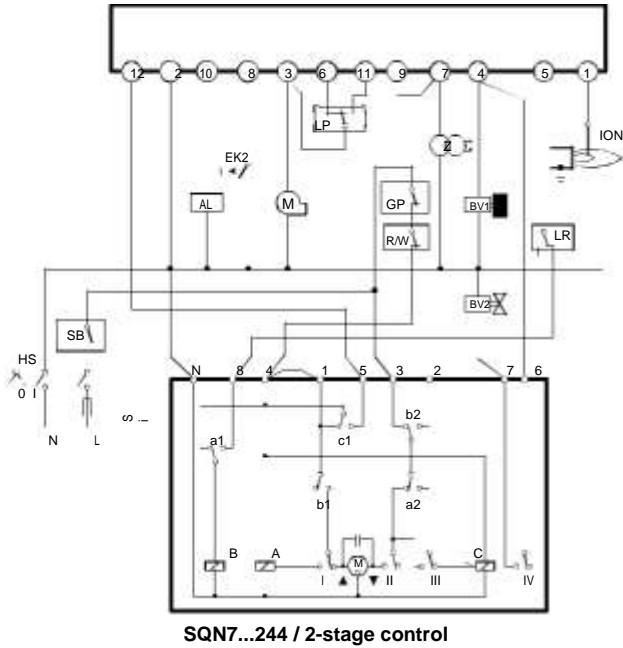

**Burner without fan and without air pressure switch (LP)**

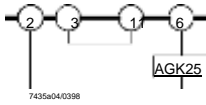

**Burner with fan control via auxiliary contactor (HS) with air pressure switch (LP)**

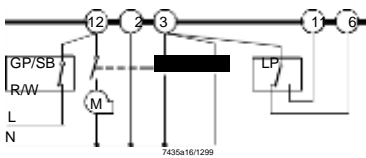

**QRA with auxiliary unit AGQ1 with LGB21 (diagram 7435a06)**

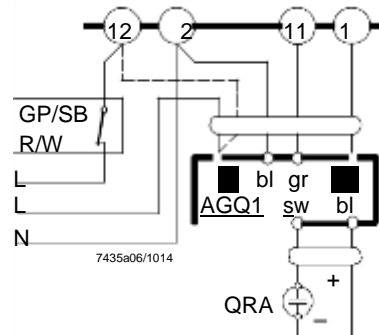

**Legend**

- bl Blue wire
- br Brown wire
- gr gray (previously: rd = red)
- sw Black wire

**Connection diagram and control sequence (cont'd)**

**LGB22 / LGB32**

Burner controls for single- or 2-stage forced draft burners.  
 Air damper control for prepurging with **nominal load air volume**.

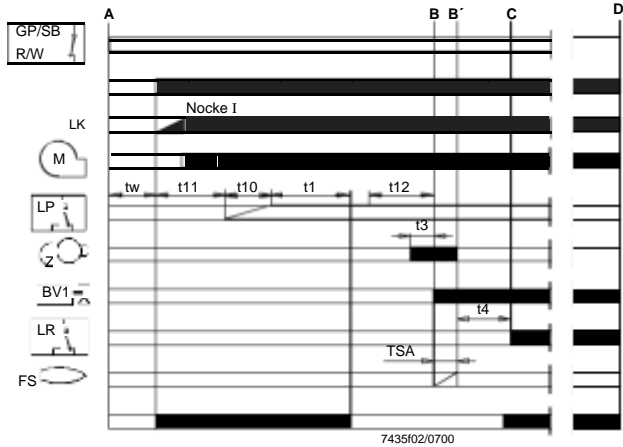

**Flame supervision**

**LGB22:** With ionization probe or auxiliary unit AGQ1 for UV detector QRA  
**LGB32:** With blue-flame detector QRC1

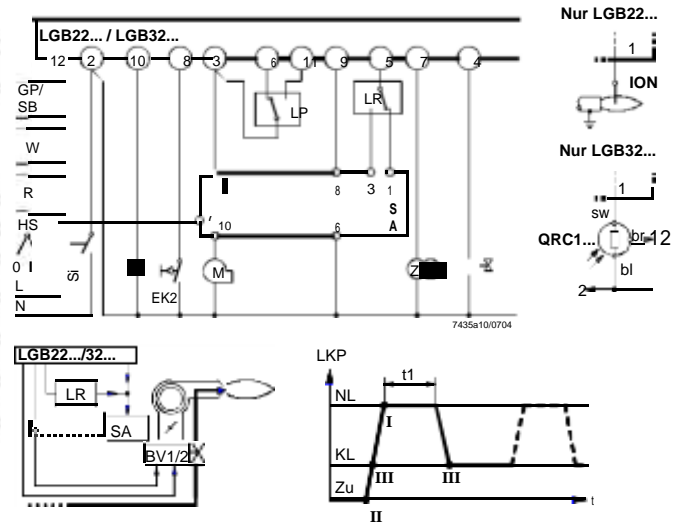

**Application examples**

Control of actuators of 2-stage or 2-stage modulating burners.  
 Prepurging (t1) with nominal load air volume.

For information about the actuators:  
 SQN3: Refer to Data Sheet N7808  
 SQN7: Refer to Data Sheet N7804  
 SQN9: Refer to Data Sheet N7806

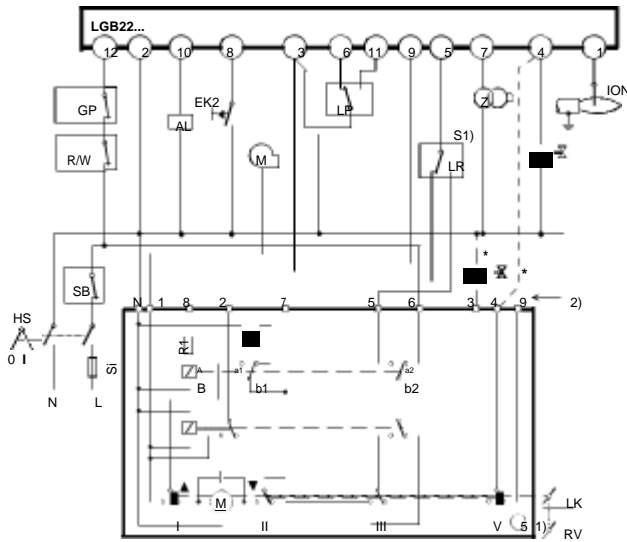

**SQN3...151 or SQN3...251**

**\* Note:**

With 2-stage modulating burners (with gas control damper (RV)), fuel valve (BV2) and the dotted connection between terminals marked (\*) are not required.

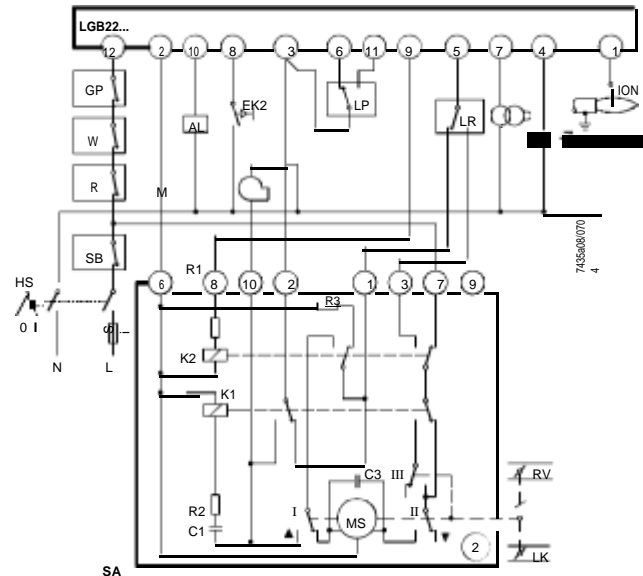

**SQN90.220 / 2-stage modulating control**

**Connection diagram and control sequence (cont'd)**

**LGB22 / LGB32**

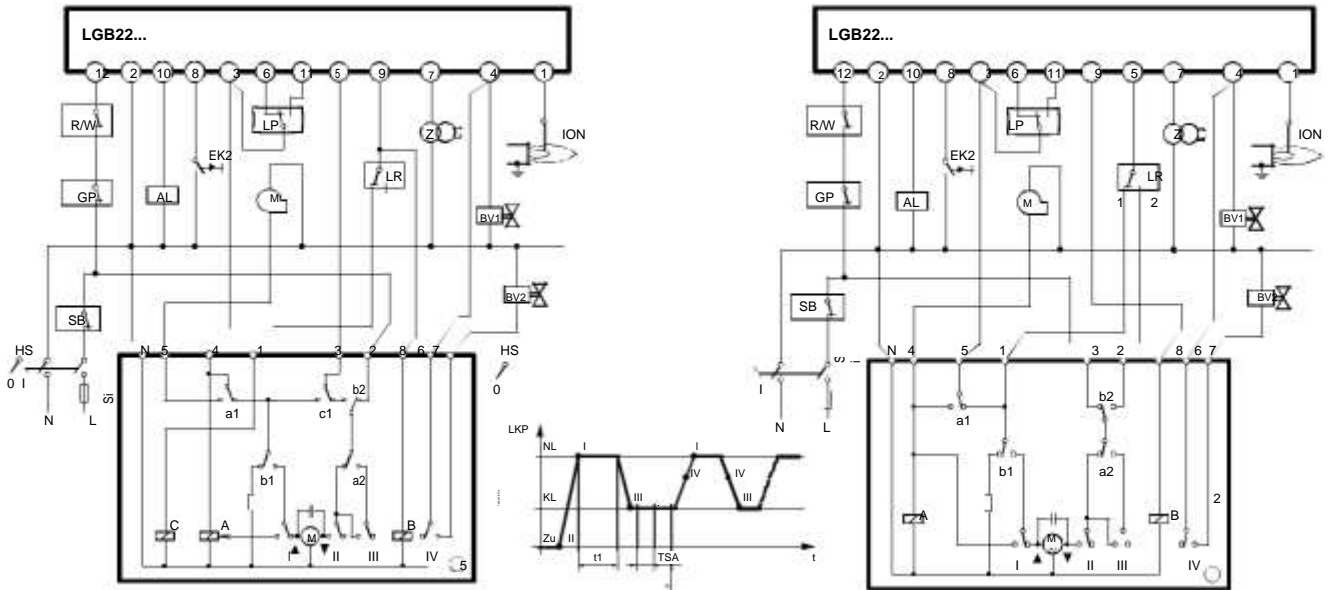

**SQN7...454 / 2-stage control**  
**Single-wire control**

Burner without fan and **without air pressure switch (LP)**

**LGB22 / LGB32**

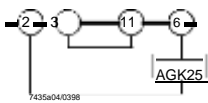

**SQN7...424 / 2-stage control**  
**2-wire control**

QRA with auxiliary unit AGQ1 with LGB22 (diagram 7435a06)

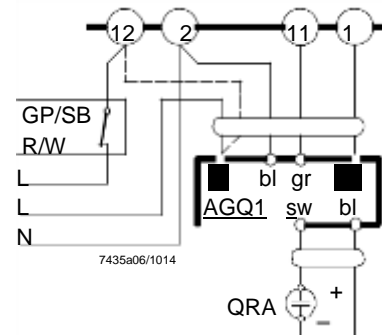

**Burner with fan control via auxiliary contactor (HS) with air pressure switch (LP)**

**LGB22 / LGB32**

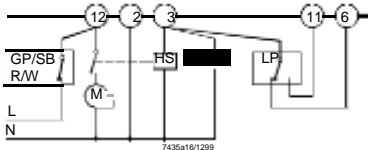

**Legend**

- bl Blue wire
- br Brown wire
- gr gray (previously: rd = red)
- sw Black wire

**Legend**

- |       |                      |    |   |
|-------|----------------------|----|---|
| TSA   | Ignition safety time | t4 | Interval fuel valve (BV1) – fuel valve (BV2)<br>LGB22 / LGB32: interval fuel valve (BV1) – load controller (LR) |
| t1    | Prepurge time        |    |   |
| AL    | Alarm                | LR | Load controller   |
| BV... | Fuel valve           | M  | Fan motor   |
| EK2   | Remote reset button  | NL | Nominal load  |
| ION   | Ionization probe     | R  | Control thermostat or pressurestat  |
| GP    | Gas pressure switch  | SB | Safety limit thermostat   |
| HS    | Mains isolator       | Si | Primary fuse  |
| KL    | Low-fire             | W  | Limit thermostat  |
| LKP   | Air damper position  | Z  | Ignition transformer  |
| LP    | Air pressure switch  |    |   |

**Connection diagram and control sequence (cont'd)**

**LGB41**

Burner controls for atmospheric gas burners with or without fan. No actuator control. Flame supervision with ionization probe

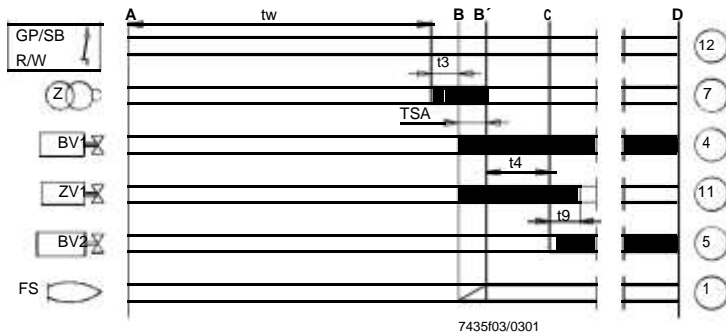

QRA with auxiliary unit AGQ1 with LGB4 (pictures 7435a21)

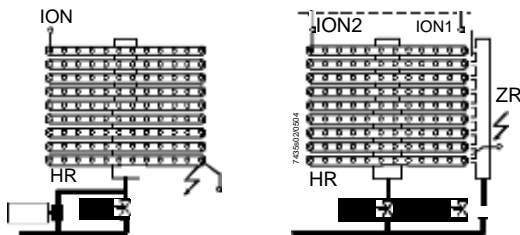
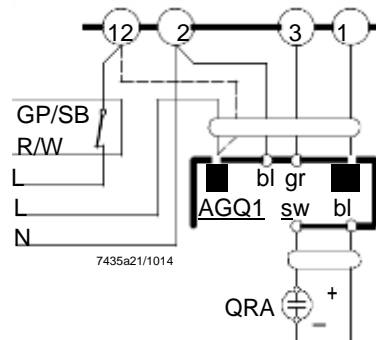
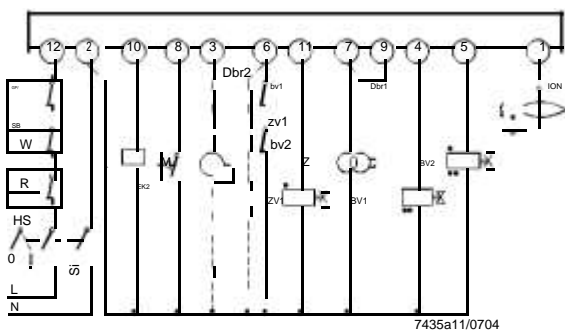

**Legend**

- A Startup (switching on by control thermostat or pressurestat (R))
- B-B' Interval for establishment of flame
- C Operation position of burner or release of the second stage by load controller (LR)
- D Shutdown by control thermostat or pressurestat (R)

- tw Waiting time
- TSA Ignition safety time
- t3 Preignition time
- t4 Interval fuel valve (BV1) – fuel valve (BV2)
- t9 2<sup>nd</sup> safety time

- Required input signals
- Burner control's output signals

- Connection of valves with pilot burners with main flame supervision
- Connection of valves with 2-stage atmospheric burners with supervision of the first stage (fuel valve (BV1))

- AL Alarm
- BV... Fuel valve
- bv... Auxiliary switch in the fuel valves (for control the closed position)
- Dbr1 Wire link
- Dbr2 Wire link, required when contacts «bv» or «zv1» is missing
- EK2 Remote reset button
- ION Ionization probe
- FS Flame signal
- GP Gas pressure switch
- HR Main ramp
- HS Main switch
- M (Auxiliary) fan motor
- QRA UV flame detector
- QRC Blue flame detector
- bl Blue wire
- br Brown wire
- gr gray (previously: rd = red)
- sw Black wire
- R Control thermostat or pressurestat
- SB Safety limit thermostat
- Si Primary fuse
- W Limit thermostat
- Z Ignition transformer
- ZR Ignition ramp
- ZV1 Ignition gas valve
- zv1 Auxiliary switch in ignition gas valve



**Internal diagram and time diagram of the programming**

**mechanisms LGB21**

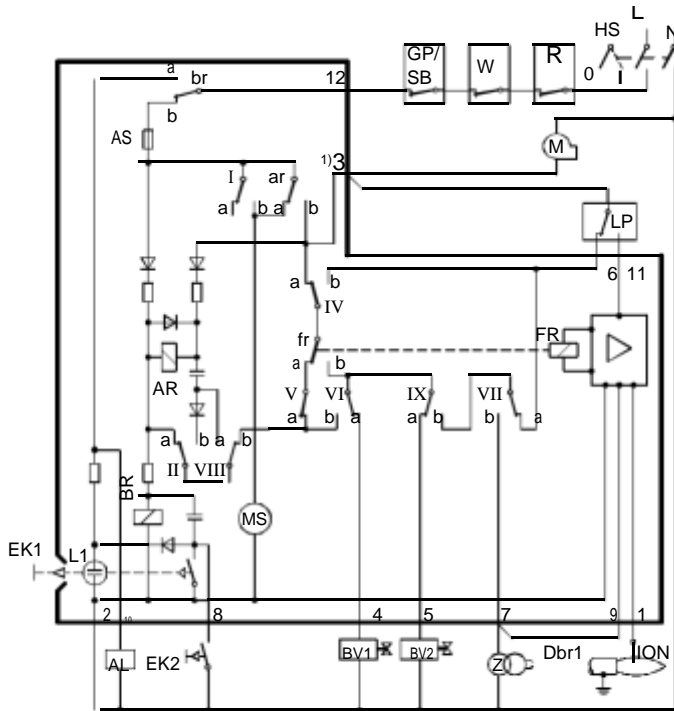

**Legend**

- AL Alarm
- AR Load relay with contact «ar»
- AS Unit fuse
- BR Locking relay with contact «br»
- BV... Fuel valve
- Dbr1 Wire link
- EK... Lockout reset button
- FR Flame relay
- GP Gas pressure switch
- HS Mains isolator
- ION Ionization probe
- L1 Lockout warning lamp
- LP Air pressure switch
- M Fan motor
- MS Synchronous motor
- R Control thermostat or pressurestat
- SB Safety limit thermostat
- W Limit thermostat or pressure switch
- Z Ignition transformer

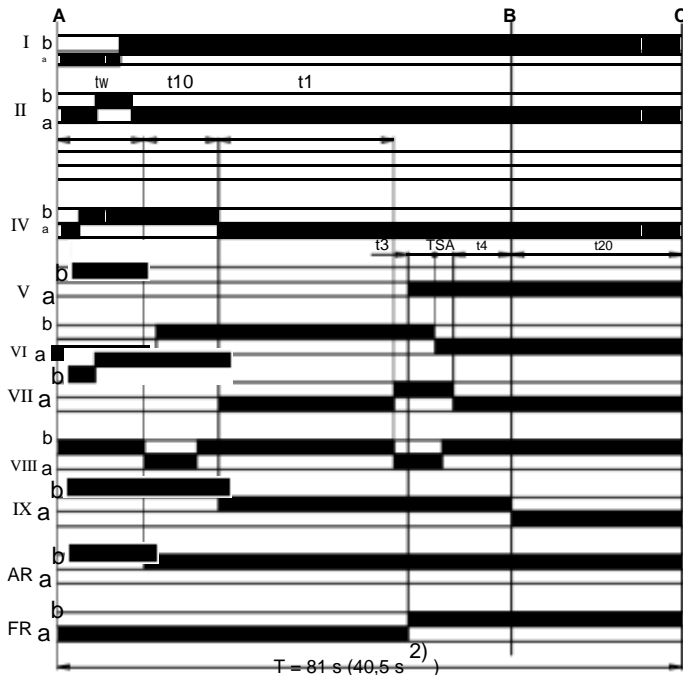

- A Start position (switching on)
- B Operating position of burner
- C Operating position of programming mechanism or start position

I...IX Cam switches

tw Waiting time

TSA Ignition safety time

T Total running time of programming mechanism

t1Purpurg time

t3 Preignition time

t4 Interval fuel valve (BV1) – fuel valve (BV2)

t10Specified time for air pressure signal

t20Interval up to self-shutdown of programming mechanism

1) Resistance between terminal 3 and «N» must not exceed 1.6 kΩ

2) Only with LGB21.130A27

**Internal diagram and time diagram of the programming mechanisms (cont'd)**

**LGB22 / LGB32**

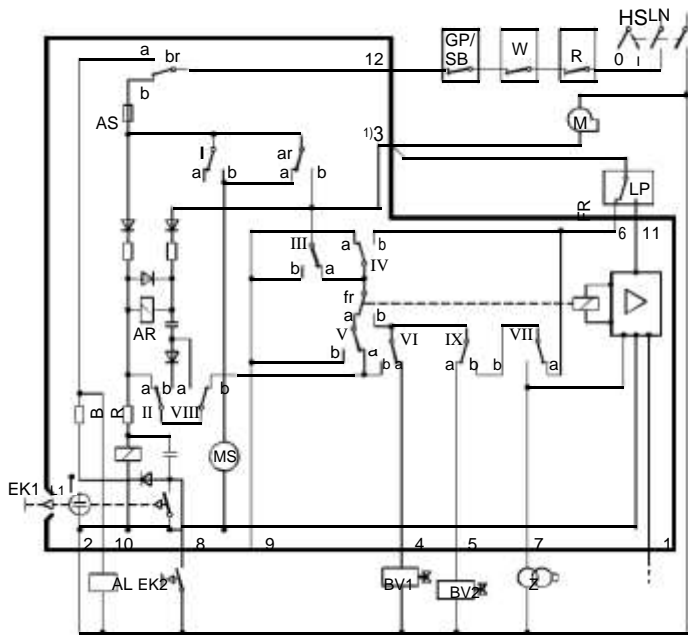

**Legend**

- AL Alarm
- AR Load relay with contact «ar»
- AS Unit fuse
- BR Locking relay with contact «br»
- BV... Fuel valve
- EK... Lockout reset button
- FR Flame relay
- GP Gas pressure switch
- HS Mains isolator
- ION Ionization probe
- L1 Lockout warning lamp
- LP Air pressure switch
- M Fan motor
- MS Synchronous motor
- R Control thermostat or pressurestat
- SB Safety limit thermostat
- W Limit thermostat or pressure switch
- Z Ignition transformer

Nur LGB22...

Nur LGB32...

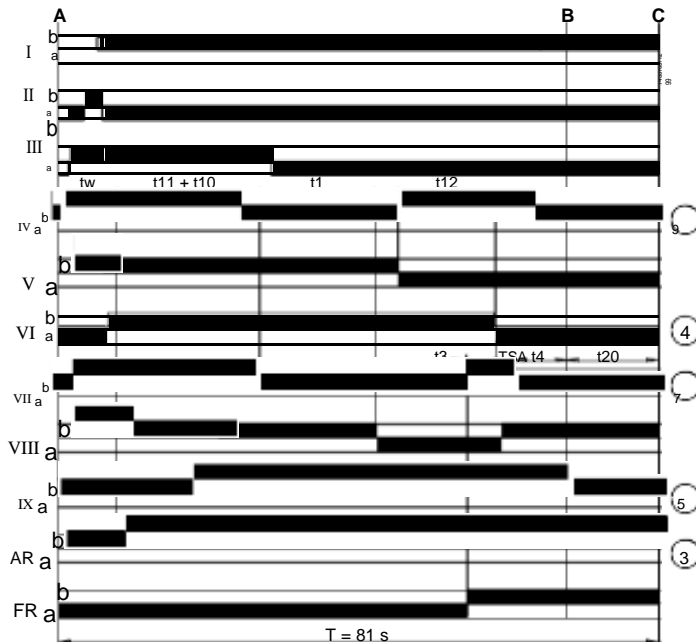
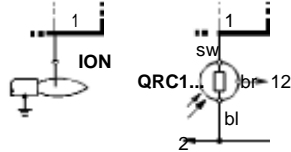

- A Start position (switching on)
- B Operating position of burner
- C Operating position of programming mechanism or start position
- I...IX Cam switches

- tw Waiting time
- TSA Ignition safety time
- T Total running time of programming mechanism
- t1Purpurg time
- t3Preignition time
- t4Interval fuel valve (BV1) – fuel valve (BV2) or fuel valve (BV1) – load controller (LR)
- t10Specified time for air pressure signal
- t11Programmed opening time for actuator (SA)
- t12Programmed closing time for actuator (SA)
- t20Interval up to self-shutdown of programming mechanism

1) Resistance between terminal 3 and «N» must not exceed 1.6 kΩ

Internal diagram and time diagram of the programming mechanisms (cont'd)

LGB41

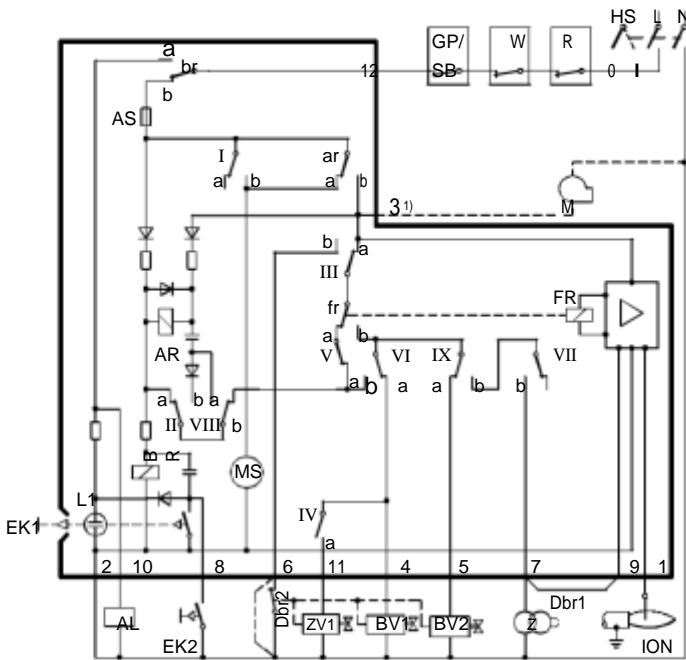

Legend

- AL Alarm
- AR Load relay with contact «ar»
- AS Unit fuse
- BR Locking relay with contact «br»
- BV... Fuel valve
- Dbr1 Wire link
- Dbr2 Wire link terminal 6-2 required when contact «bv» or «zv1» is missing
- EK... Lockout reset button
- FR Flame relay
- GP Gas pressure switch
- HR Main burner
- HS Mains isolator
- ION Ionization probe
- L1 Lockout warning lamp
- M Fan motor
- MS Synchronous motor
- R Control thermostat or pressurestat
- SB Safety limit thermostat
- W Limit thermostat or pressure switch
- Z Ignition transformer
- ZR Pilot burner
- ZV1 Pilot gas valve in place of fuel valve (BV1) in the case of pilot burners with main flame supervision

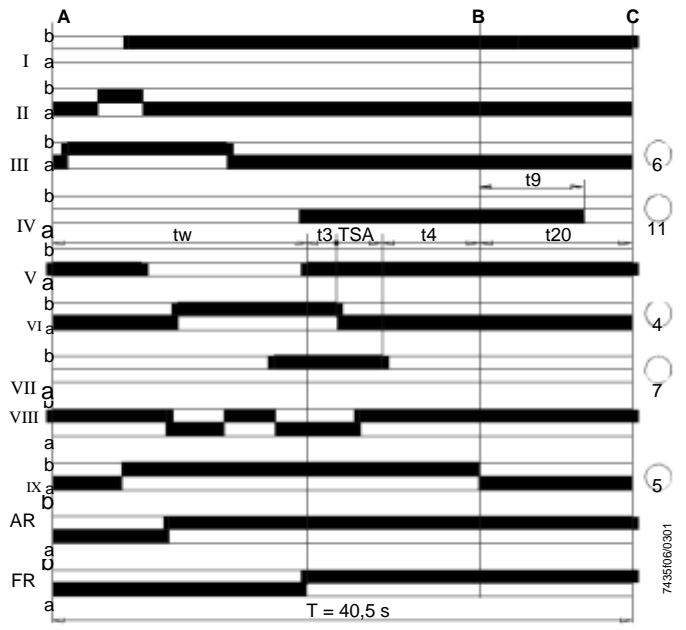

- tw Total running time of programming mechanism
- t3 Preignition time
- t4 Interval fuel valve (BV1) – fuel valve (BV2)
- t9 Second safety time
- t20 Interval up to self-shutdown of the programming mechanism

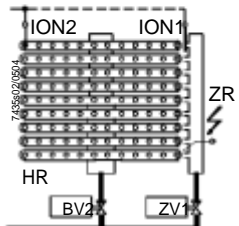
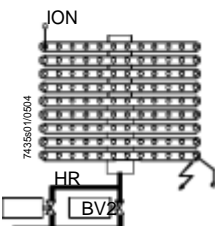

- A Start position ( switching on)
- B Operating position of burner
- C Operating position of programming mechanism or start position
- I...IX Cam switches
- 1) Resistance between terminal 3 and «N» must not exceed 1.6 kΩ

**Dimensions**

Dimensions in mm

LGB

  
 Plug-in base AGK11

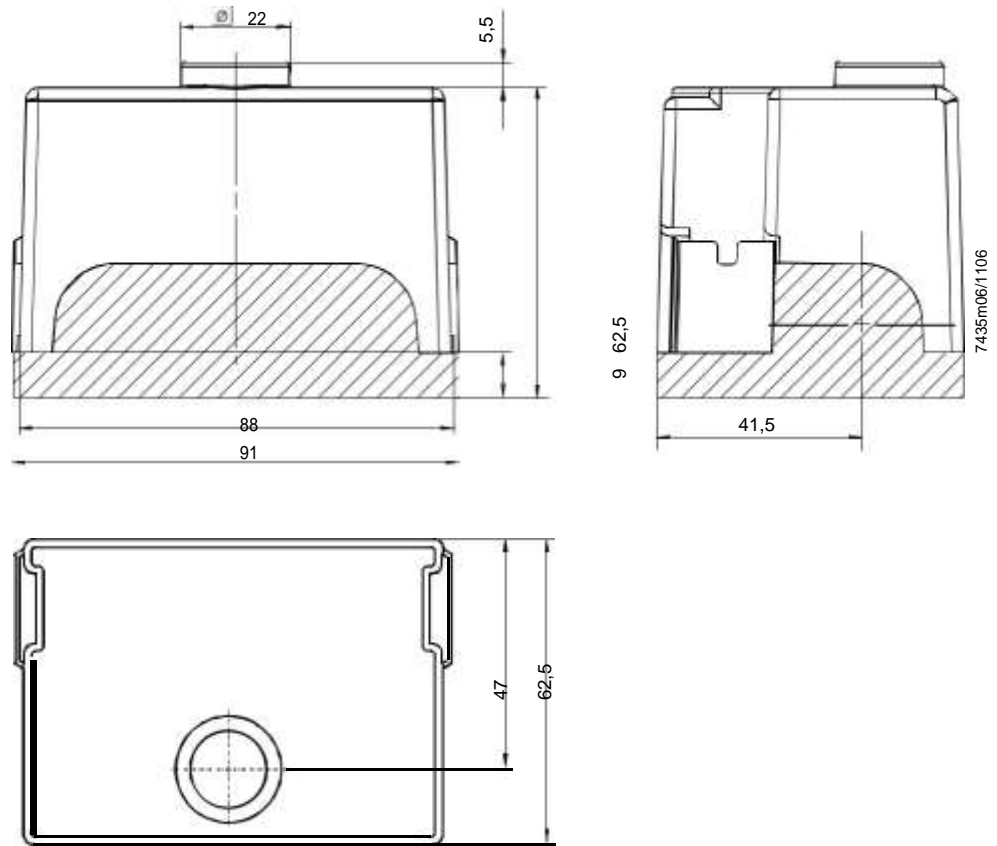

Auxiliary unit  
 AGQ1.xA27

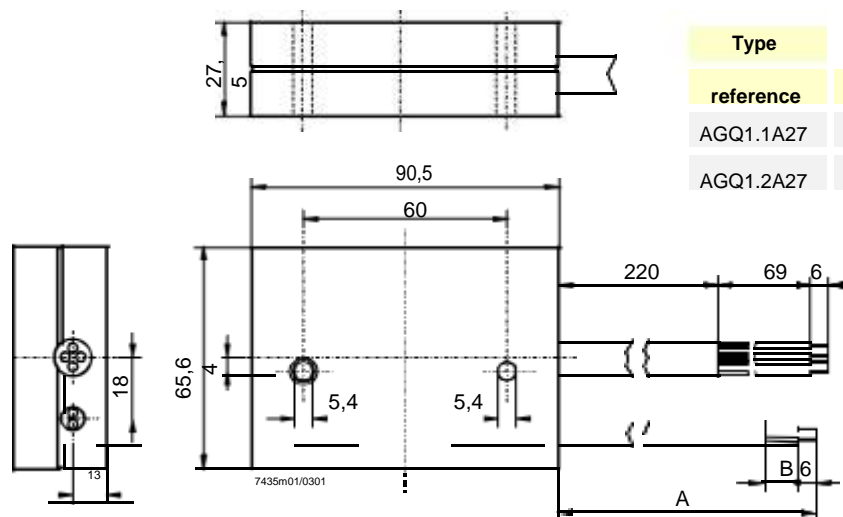

Type	Dimension	
	A	B
reference		
AGQ1.1A27	500	19
AGQ1.2A27	300	34