

# SIEMENS

# 7<sub>643</sub>



SKP15...

SKP25... / SKL25...

SKP55...

SKP75...

## Actuators for Gas Valves

## SKPx5... SKL25...

- ON / OFF safety shutoff feature conforming to EN 161 in connection with SKPx5... actuators and gas valves from Siemens
- Damped opening (rapid closing)
- Very low power consumption
- Suitable for gases of gas families I...III
- Optionally with / without end switch (factory set)
- Plug-in connection facility
- Electrical indication of operation
- Stroke indication
- Supplementary Data Sheets (refer to the Data Sheets on gas and air valves)

The SKPx5... / SKL25... and this Data Sheet are intended for use by OEMs which integrate the actuators in their products.

**Use**

SKP... actuators are designed for use with the following types of valves:

Type of valve	Medium	Data Sheet
VGG... VGF... VGH...	Natural gas Gases of gas families I...III	N7636
VGD2... VGD4...	Natural gas Gases of gas families I...III	N7631
VRF... VRH...	Biogas (used with SKPx5..., on request)	N7633
VLF...	Hot air	N7637

**Actuators in general**

The combination of actuator and valve provides the following functions:

- Safety shutoff valve (SKP15...)
- Safety shutoff valve with gas pressure governor / controller (SKP25..., SKP55..., and SKP75...)

The electrohydraulic actuators together with the valves are designed for use with gases of gas families I...III and air. They are used primarily on gas-fired combustion plant. The actuators open slowly and close rapidly. They can be combined with any of the above mentioned valve types and nominal valve sizes. The actuator can be supplied with end switch (for indicating the fully closed position). For information about valve sizing, refer to the «Valve sizing chart» in the Data Sheet of the relevant valve.

**SKP25...**

The SKP25... operates as a constant pressure governor with a setpoint spring.

Its field of use is primarily forced draft gas burners

- with mechanical air / fuel ratio control
- with electronic air / fuel ratio control

**SKP25.7...**

The SKP25.7... operates like the SKP25... constant pressure governor, but features electric adjustment of the setpoint spring.

Its field of use is primarily

- atmospheric burners in modulating or multistage operation
- individual burners or groups of burners on industrial furnaces
- plant with remote control of the air ratio with burners using a direct mechanical link

**SKL25...**

The SKL25... actuators are of the same design as the SKP25..., but close more slowly (in 3...6 seconds).

The SKL25... do not conform to the standards for gas applications and, for this reason, are only suited for use with air.

**SKP55...**

The SKP55... operates as a differential pressure governor.

Its field of use is predominantly

- combustion plant with combined heat recovery systems
- plant where pressure conditions in the burner and combustion chamber do not change in proportion to load changes
- burners with adjustable air / fuel mixing devices in the burner head
- plant with negative pressure levels on the gas or air side

**SKP75...**

The SKP75... operates as a pressure ratio controller and provides control of the gas pressure depending on the pressure of the combustion air, ensuring that the gas / air ratio remains constant across the entire load range.

Its field of use is primarily modulating forced draft gas burners.

**Warning notes**



**To prevent injury to persons, damage to property or the environment, the following warning notes should be observed!**

**Do not open, interfere with or modify the actuators!**

- All activities (mounting, installation and service work, etc.) must be performed by qualified staff
- Check to ensure that the impulse pipes are properly fitted and tight
- Fall or shock can adversely affect the safety functions. Such actuators must not be put into operation, even if they do not exhibit any damage
- Each time work has been carried out (mounting, installation, service work, etc.), check to ensure that wiring is in an orderly state and make the safety checks as described in «Commissioning notes
- If mains voltage is fed to the end switch via the second plug-in space, protective earth must be connected to the actuator via the same plug
- Use of connectors conforming to DIN EN 175301-803-A is mandatory
- The connectors used must feature cable strain relief
- The pump's stem must not be pulled out using the overstroke element since that part could become loose



SKP15... / SKP25...  
 with connecting cable  
 AGA62.000A000

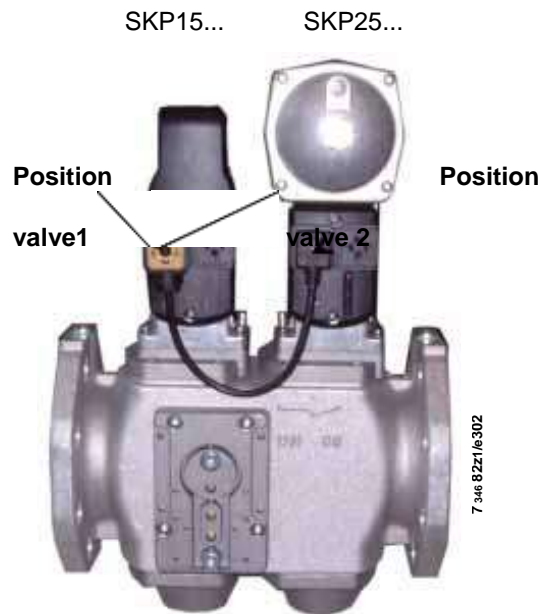

VGD40...

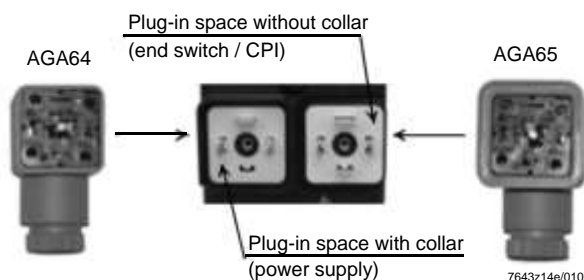

For connection of end switch, a connector with collar should be used (protection against electric shock hazard), refer to "Accessories"!

## Engineering notes

Design of the gas train	If the available gas pressure exceeds the maximum permissible operating pressure of the valve / actuator (refer to the Data Sheet of the relevant valve), it must be lowered by an upstream pressure controller. The pressure switch for lack of gas must always be fitted upstream of the gas valve when used in connection with the actuator. The inside diameter of the impulse pipes must be a minimum of 6 mm.
SKP25..., SKL25..., SKP55..., SKP75...	The impulse pipes must be installed such that the differential pressure can be acquired with no disturbance (unfavorable flow conditions). Pressure test points must not protrude and be flush with the inside diameter of the pipe or duct wall. The impulse lines to the governor / controller should be as short as possible, enabling the governor / controller to respond quickly should sudden load changes occur.
SKP75...	<ul style="list-style-type: none"> <li>Installation of impulse pipes                      In the case of unsafe combustion chamber pressure pipes (e.g. resulting from potential leaks); the setting must also be checked during operation without having the combustion chamber pipe connected, especially with respect to maximum burner capacity. The impulse pipes must be fitted such that the differential pressure can be acquired with no disturbance. With gas / air ratios &gt; 3, the impulse pipes for the combustion air and the combustion chamber pressure must have an inside diameter of at least 8 mm. The impulse pipe for the combustion chamber pressure must be fitted such that the gases will cool down in the vicinity of the impulse pipe and condensing gases cannot enter the controller but will return to the combustion chamber.</li> </ul> <p>Recommendations:</p> <ul style="list-style-type: none"> <li>The gas pressure should be acquired at a distance of 5 times the nominal pipe size downstream from the valve</li> <li>Do not use the lateral test points on the valve body for picking up the pressure</li> </ul> <ul style="list-style-type: none"> <li>Considering the combustion chamber pressure                      If the resistance value of the combustion chamber / heat exchanger / stack system is constant, the combustion chamber pressure changes in proportion to the gas and combustion air pressure as the burner's output changes. In that case, the combustion chamber pressure need not be fed to the SKP75... as a disturbance variable. However, if the combustion chamber pressure does not change to the same extent as the gas and air pressure – as this is the case in plants with flue gas fan or modulating flue gas damper – the combustion chamber pressure must be fed to the SKP75... as a disturbance variable, enabling the controller to counteract.</li> </ul>

## Mounting notes

- Ensure that the relevant national safety regulations are complied with
- The quadratic arrangement of the fixing holes allows the actuator to be fitted in 4 different positions, each step being 90°
- The actuator can be mounted or replaced while the system is under pressure; seal-ing materials are not required
- Follow the Mounting Instructions included with the actuators:
  - For SKP15...: M7643
  - For SKP25...: M7643.1
  - For SKL25...: M7643
  - For SKP25.7...: M7644
  - For SKP55...: M7643.2
  - For SKP75...: M7643.3

**Installation and commissioning notes**

Actuators in general

- Electrical commissioning may only be performed when the actuator is fitted to the valve; otherwise, the actuator can be damaged
- Power is supplied and connection of the end switch is made directly via a connecting cable (conforming to DIN EN 175301-803-A)
- The end switch is factory-set

Functioning principle of 1-stage actuator with safety shutoff feature

When power is applied, the pump will be activated and the control valve closed. Oil is now pumped from the chamber below the piston to the pressure chamber above the piston. The oil pressure causes the piston to move downward, thereby opening the valve – against the pressure of the closing spring. The pump remains energized until the closing command is given. When power is removed, or in the event of a power failure, the pump will be deactivated and the control valve opened so that the closing spring pushes the piston back. The return flow system is sized such that the counter-stroke required for reaching the fully closed position is completed within about 0.6 seconds.



For 2-stage actuators, refer to Data Sheet N7641.  
 (Schematic drawing)

SKP15... complete with valve

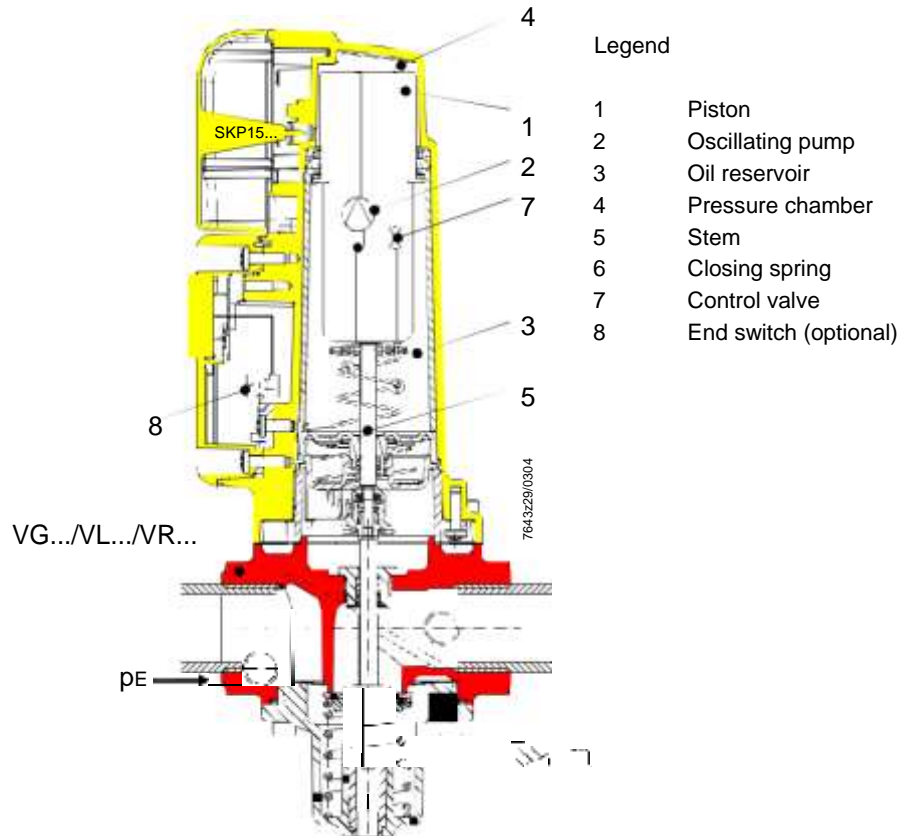

**Installation and commissioning notes (cont'd)**

SKP2... , SKP5... and SKP7... control a bypass valve via their pneumatic controller, thereby opening the gas valve.

SKP25... complete with valve

(Schematic drawing)

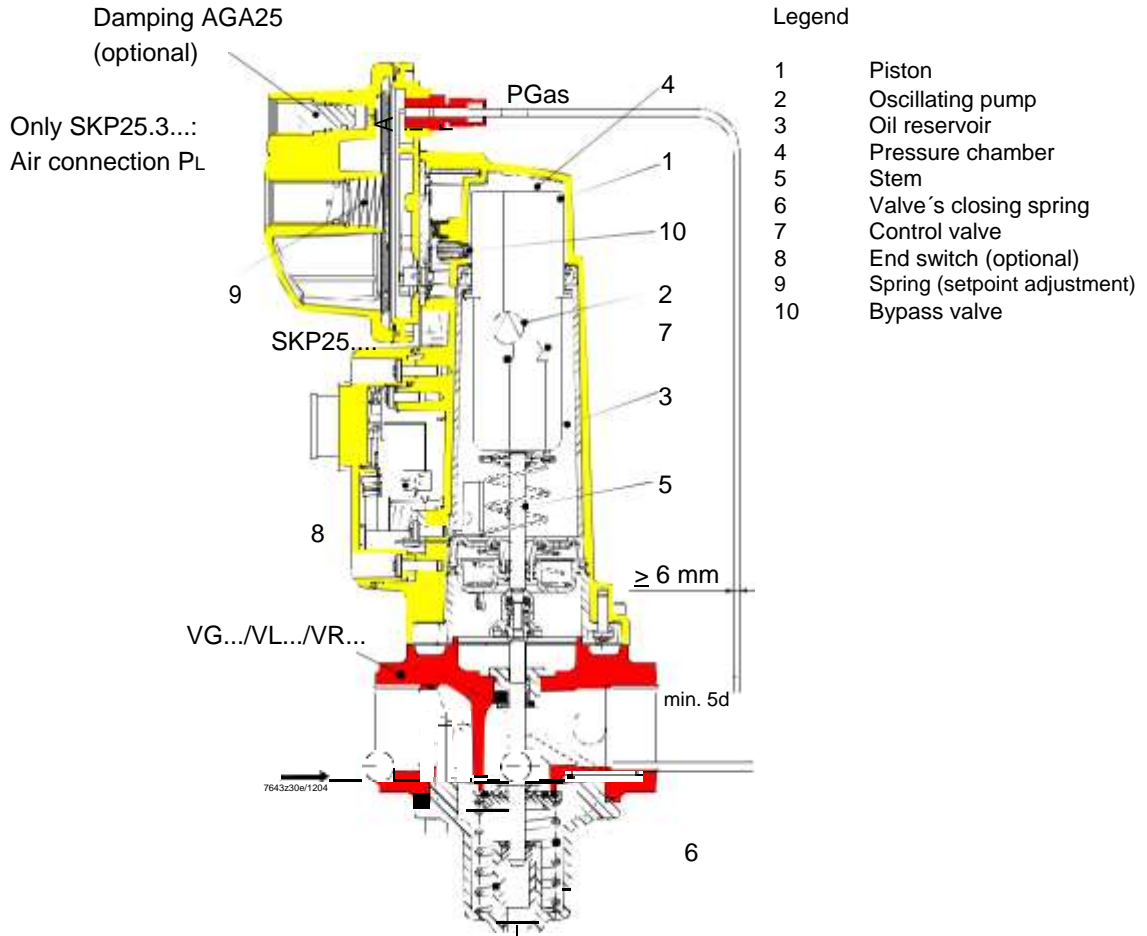

SKP25...

The setpoint adjustment «PGas» must be made manually by turning the adjusting screw, which acts on the setpoint spring (for setpoint springs, refer to «Accessories»).

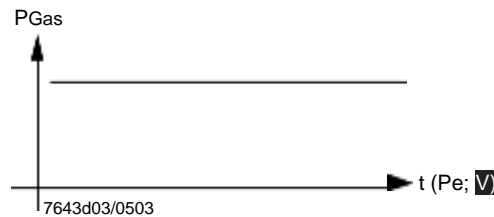

- Legend
- $P_e$  Inlet pressure
  - $V$  Volumetric flow
  - PGas 0...22 mbar (with AGA29 standard spring), presetting 15 mbar

SKP25.3...

The SKP25.3... operates based on the zero governor principle (PL : PG = 1:1). By feeding fan pressure «PL» to the air inlet, the gas pressure «PGas» follows with a fixed 1-to-1 ratio.

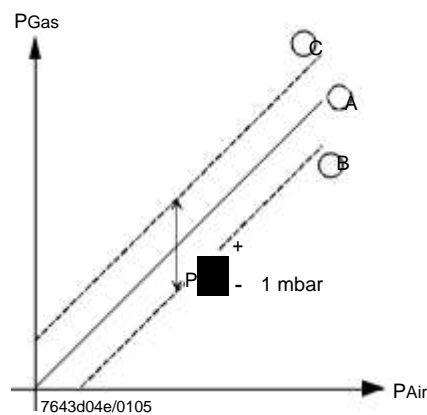

- A** Gas / air ratio for stoichiometric combustion
- B** At low-fire, the parallel displacement of the working characteristic produces a larger amount of excess air in percent. The zero governor makes possible a parallel displacement in both directions, towards «Excess air» **C** and «Lack of air» **A**

**Installation and commissioning notes (cont'd)**

SKP25.4... The SKP25.4... is suited for the control of higher pressures.  
 Standard spring 0...1,500 mbar.

SKP25.4... (Schematic drawing)  
 complete with valve

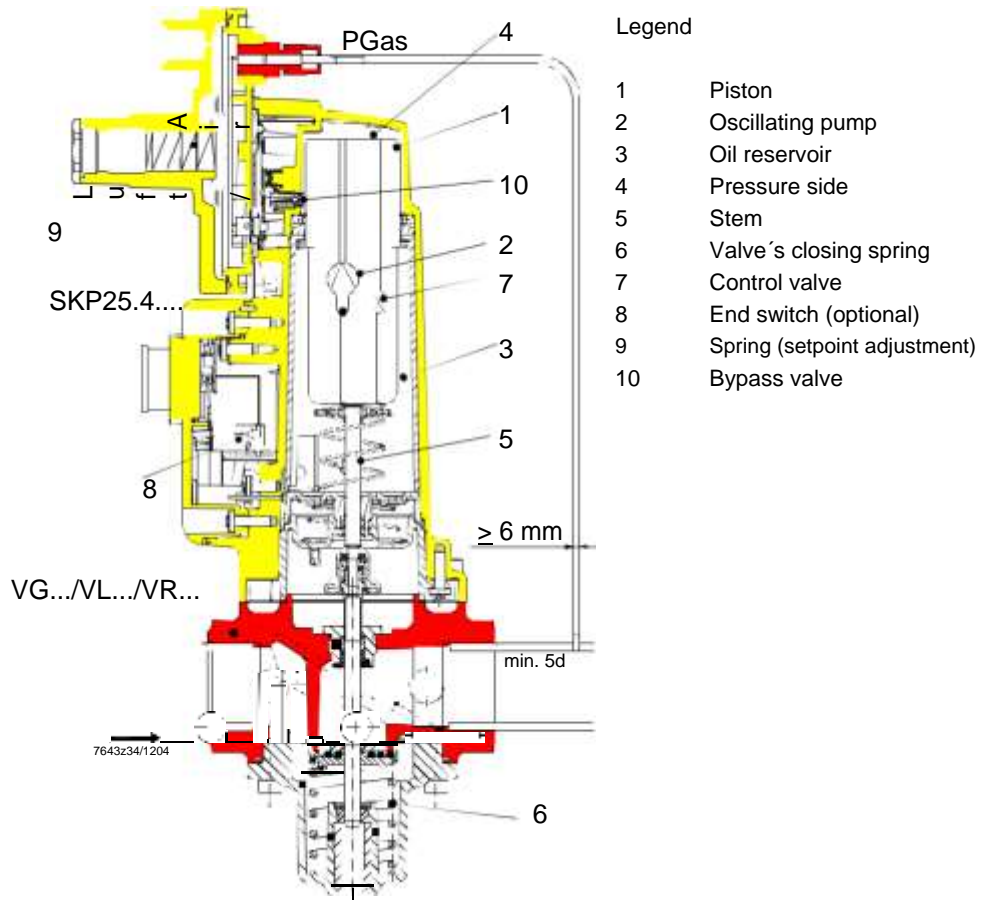

SKP25.4... Setpoint adjustment «PGas» is made manually by turning the adjusting screw, which acts on the setpoint spring (for setpoint springs, also refer to «Accessories»).

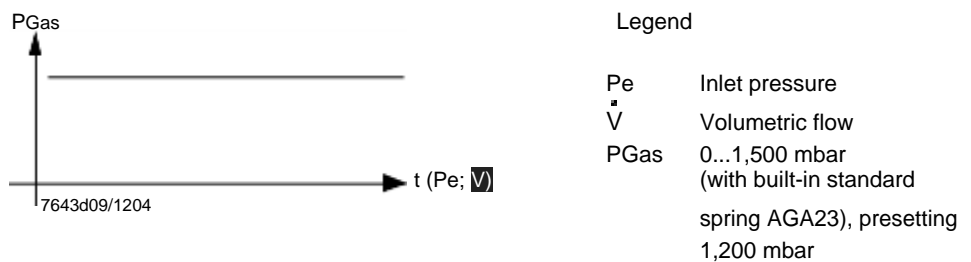

SKL25... Setpoint adjustment «PGas» is made manually by turning the adjusting screw, which acts on the setpoint spring (for setpoint springs, also refer to «Accessories»).

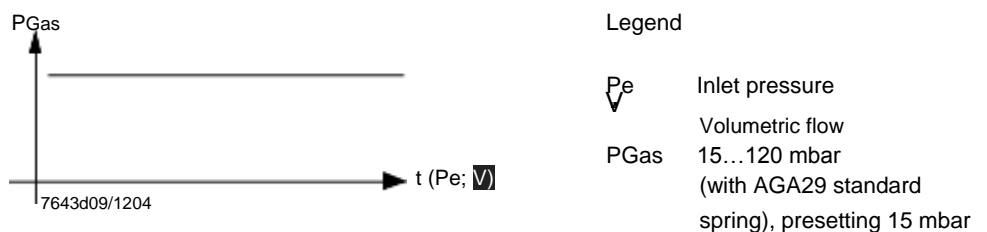

**Installation and commissioning notes (cont'd)**

SKP25.7...

Functioning principle of gas pressure governor with SQS37 motorized setpoint adjuster:

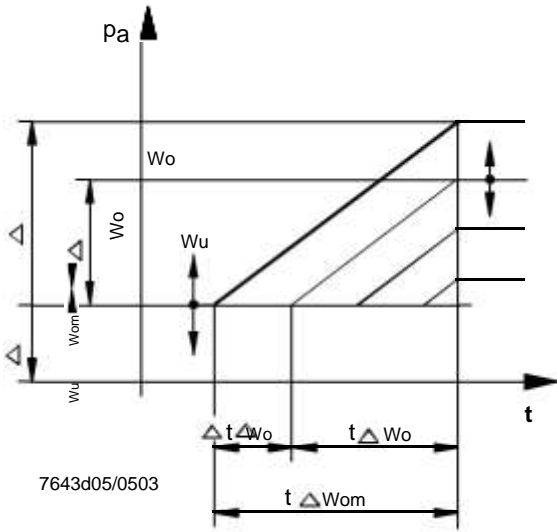

On the gas outlet side, the gas pressure governor maintains the pressure at the required setpoint. The electrical signal fed to the SQS37 motorized setpoint adjuster changes the preadjusted setpoint in proportion to the length of the electrical pulse, either increasing or decreasing, depending on the direction of the pulse signal. When the preset maximum or minimum setpoint is reached, the outlet pressure will remain at a constant level. The time required to traverse the upper setpoint range « $\Delta w_o$ » is the same in both directions. The running time « $t_{\Delta w_o}$ » changes in proportion to the change of the upper setpoint range « $\Delta w_o$ ». At the lower setpoint limitation « $\Delta w_u$ », the SQS37 runs idle during the period of time « $t_{\Delta w_u}$ », which means that a certain part of it can occur as dead time.

SKP25.7... complete with valve (Schematic drawing)

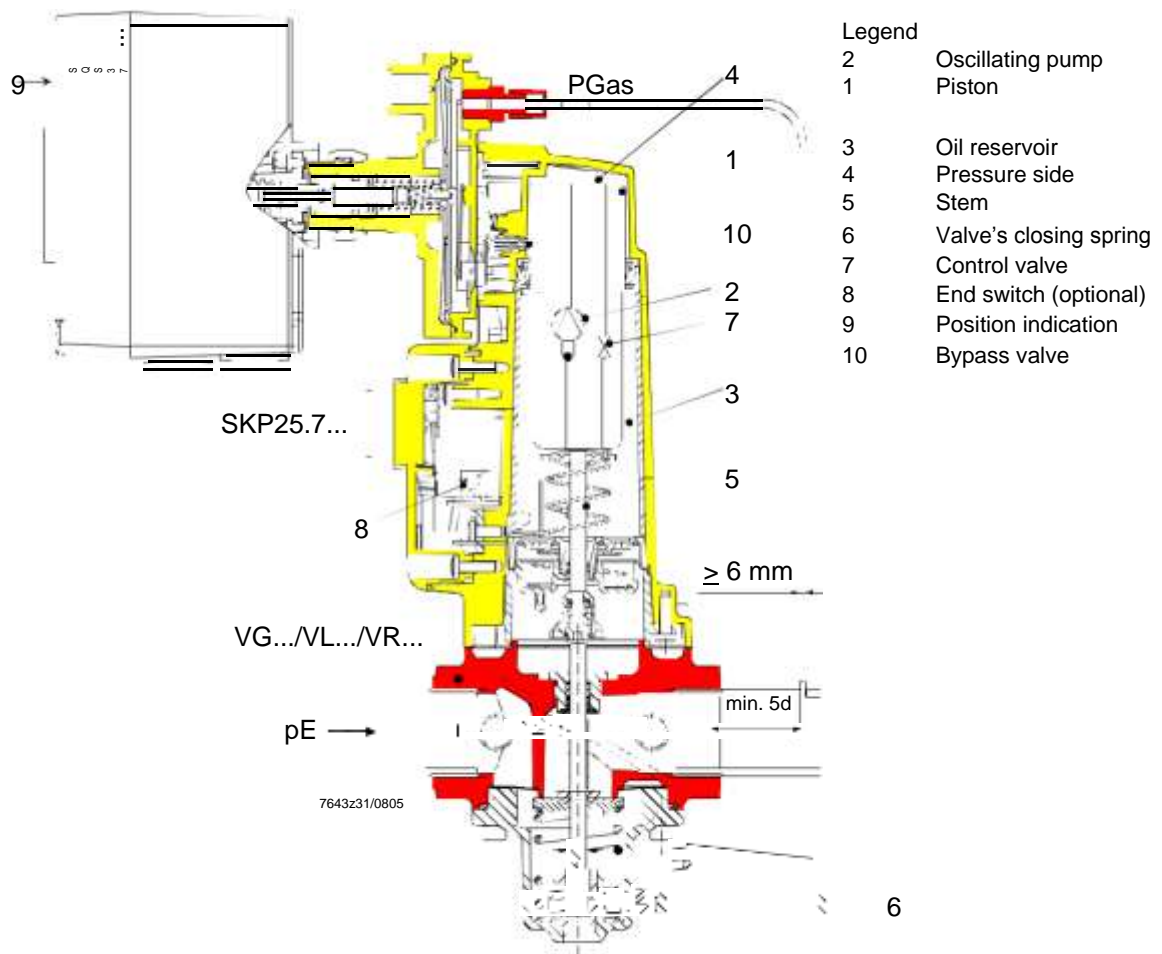



### Installation and commissioning notes (cont'd)

Setpoint springs for SKP25.7... Delivery ex works for the following setpoint ranges:  
 $\Delta wu$  0.5...4 mbar  $\pm 15\%$   
 $\Delta wo$  0...18 mbar  $\pm 15\%$

For springs required for other pressure ranges, please refer to the following table.

Setpoint ranges other than the standard range can be selected by changing the springs. Each SKP25.7... is supplied with 7 additional springs in a plastic bag, which can be fitted on site, if required.

Spring		$\Delta wo$ mbar $\pm 15\%$	Spring		$\Delta wu$ mbar $\pm 15\%$
Color	dia. [mm]		Color	dia. [mm]	
White	7	0... 10	Steel-colored *	12	0.5... 4
Steel-colored *	7	0... 18	Green	12	2 15...
Red	7.5	0... 45	Yellow	12.5	15... 120
Green	8	0... 90	Red	12.5	100... 250
			Blue	13	10... 30

\* The steel-colored springs are fitted in the SKP25.7...

Setpoint springs for  $\Delta wo$  cannot be used for  $\Delta wu$ , and vice versa (refer to spring dia. in the table). All combinations of  $\Delta wo$  and  $\Delta wu$  are possible.

**Installation and commissioning notes (cont'd)**

SKP55... complete with valve

(Schematic drawing)

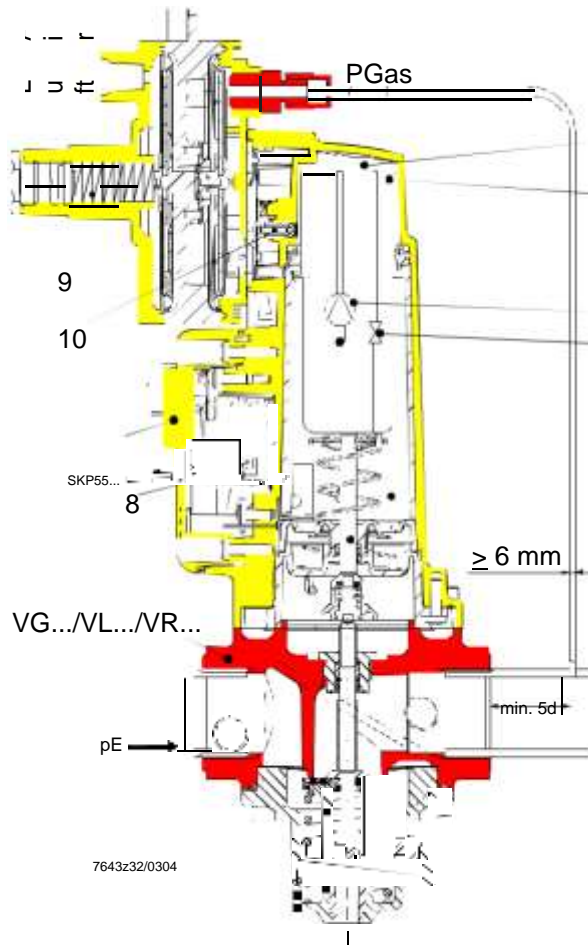

**Legend**

- 1 Piston
- 4 2 Oscillating pump
- 3 Oil reservoir
- 1 4 Pressure chamber
- 5 Stem
- 6 Valve's closing spring
- 7 Control valve
- 2 8 End switch (optional)
- 7 9 Spring (setpoint adjustment)
- 10 Bypass valve

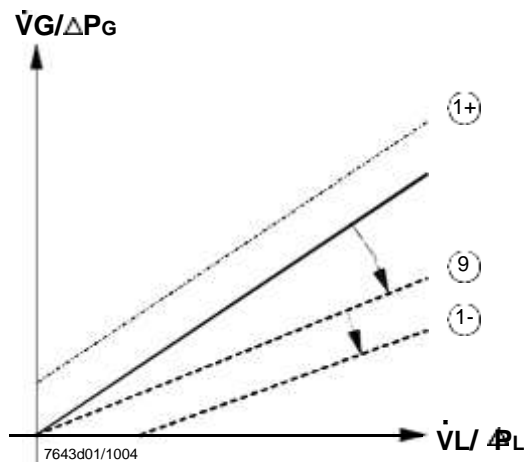

**Example:**

Adjusted gas / air ratio for burner operation with excess gas  $1+$ . The percentage of excess air is constant across the entire load range. Gas / air ratio adjustment with the adjustable orifice on the gas side (see position  $\&$ ).

**Legend**

- $\dot{V}_L$  Volumetric air flow
- $\dot{V}_G$  Volumetric gas flow

Installation and commissioning notes (cont'd)

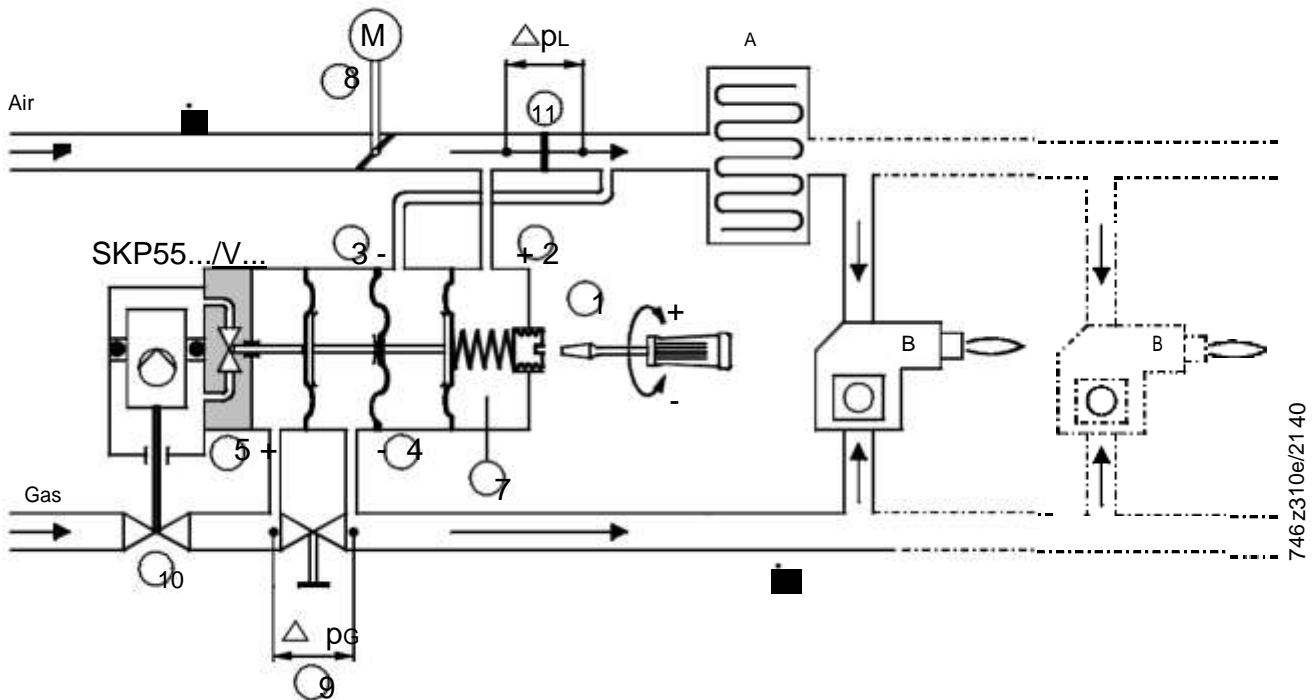

**Safety notes:**

Air damper  $\mathcal{E}$  / orifice  $\bigcirc$  must always be located as shown, that is, orifice  $\bigcirc$  must be installed downstream from the air damper  $\mathcal{E}$ .

Gas valve  $\bigcirc$  (VG...)/ orifice  $\&$  must always be located as shown, that is, orifice  $\&$  must be installed downstream from the gas valve  $\bigcirc$ .



- $\mathcal{M}$  Adjustment of parallel displacement of working characteristic  
\* Check combustion values with cap fitted
- $\mathcal{P}$  Test point for air pressure (+)
- $\mathcal{M}$  Test point for air pressure (-)
- $\mathcal{X}$  Test point for gas pressure (-)
- $\mathcal{V}$  Test point for gas pressure (+)
- $\mathcal{Z}$  Stroke indication
- $\mathcal{H}$  Spring (parallel displacement)
- $\mathcal{E}$  Actuating device (air)
- $\&$  Orifice (gas)
- $\bigcirc$  Gas valve
- $\bigcirc$  Orifice (air)
- $\bigcirc$  Indication of operating state (LED)

Legend

- $\Delta pG$  Differential pressure across orifice on the gas side
- $\Delta pL$  Differential pressure across orifice on the air side
- A Air heating coil (recuperator)
- B Burner
- M Actuator

## Installation and commissioning notes (cont'd)

- Adjustment of governor on modulating burners prior to startup:
  - The adjusting screw  $M$  on the SKP55... should be set to a gas / air ratio curve which passes through the neutral point. The SKP55... is supplied with that factory setting.  
Adjustment in the field can be made as follows: Note:  
Fit cap again before measuring the combustion value and after the setting is made.  
Turn adjusting screw  $M$  in counterclockwise direction until spring  $X$  is completely loose. Shut off the gas supply upstream of the SKP55... Switch on the SKP55... Turn adjusting screw  $M$  in clockwise direction until valve opens
  - Bring the adjustable orifice  $E$  to the precalculated value. That value with the same pressure differential on the air and gas side must lead to practically stoichiometric combustion
  - Start the burner and run it to about 90 % of the nominal load
  - Measure the combustion quality and make adjustments of the flow rate with the adjustable orifice  $E$  until optimum measured values are reached (fine adjustment)
  - Return to low-fire operation. Check the combustion and readjust if necessary the position of the working characteristic with the setting screw  $M$  on the SKP55... until optimum measured values are reached. Clockwise rotation → more gas. Counterclockwise rotation → less gas, that is, parallel displacement of the working characteristic towards lack of air or excess air
  - Limit the air damper  $e$  for low-fire operation
  - If a significant parallel displacement of the working characteristic was required, the setting must be checked again at 90 % of the nominal load and then readjusted, if required
  - Run the burner to the predefined nominal load with the help of the air damper  $e$  and limit the actuator position for that load
  - Check the flue gas values at a few positions of the load range. Make readjustments in the nominal load range with the adjustable orifice  $E$ , and in the low-fire range with screw  $M$  on the governor of the SKP55...

**Installation and commissioning notes (cont'd)**

SKP75... complete  
 with valve

(Schematic drawing)

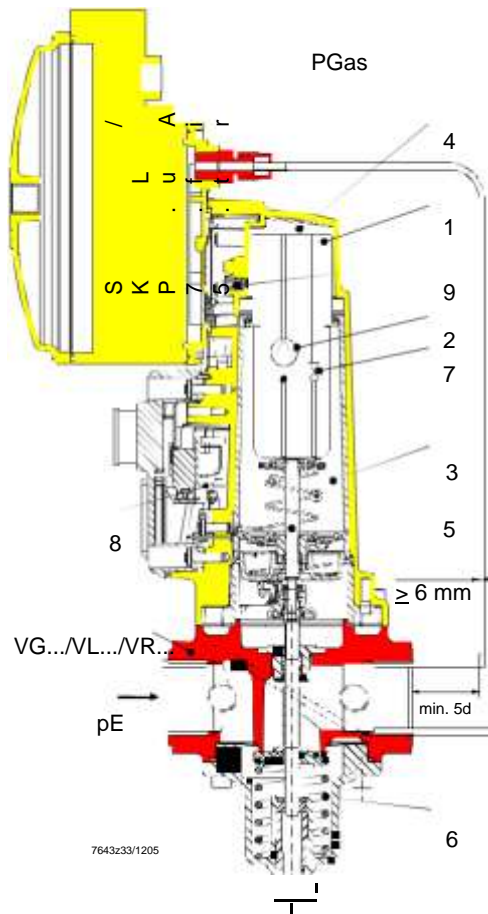

**Legend**

- 1 Piston
- 2 Oscillating pump
- 3 Oil reservoir
- 4 Pressure chamber
- 5 Stem
- 6 Valve's closing spring
- 7 Control valve
- 8 End switch (optional)
- 9 Bypass valve

Adjustment of governor  
 on modulating burners

- Use setting screw  $\eta$  / «PGAS» / «PAIR» to set the gas / air ratio to the required value (coarse setting) and the scale  $\zeta$  with setting screw  $\alpha$  to zero (refer to Fig. 7643z03)
- Start the burner and run it to about 90 % of the nominal load
- Measure the CO<sub>2</sub> or O<sub>2</sub> content of the flue gases and optimize the adjustment with setting screw  $\eta$  / «PGAS» / «PAIR»  $\zeta$  (refer to Fig. 7643z03)
- Return to low-fire operation, check the CO<sub>2</sub> or O<sub>2</sub> content of the flue gases. If necessary, readjust position of the working characteristic with setting screw  $\alpha$  /  $\zeta$
- Limit the air damper position for low-fire operation

Meaning of setting screw markings:

- + more gas
- less gas

**Installation and commissioning notes (cont'd)**

If a significant parallel displacement of the working characteristic was required to obtain optimum CO<sub>2</sub> or O<sub>2</sub> values in low-fire operation, the adjustment of the pressure ratio at nominal load or 90 % of the nominal load must be checked again and readjusted, if required.

- Run the burner to the required output and limit the nominal load air damper position
- Check the flue gas values at various positions of the load range

If readjustments are required:

- Use setting screw  $\mathcal{M}$  / «PGAS» / «PAIR»  $\triangleleft$   $\rightarrow$  in the nominal load range
- Use setting screw  $\Omega$  /  $\triangleleft$   $\rightarrow$  to make parallel displacements of the characteristic in the flow-fire range

If the gas / air pressure ratio lies outside the setting range, an orifice in the gas or air flow can be used to adjust the pressure at the test points on the burner side. Prerequisite is that there is a sufficient gas or air pressure reserve on the inlet side.

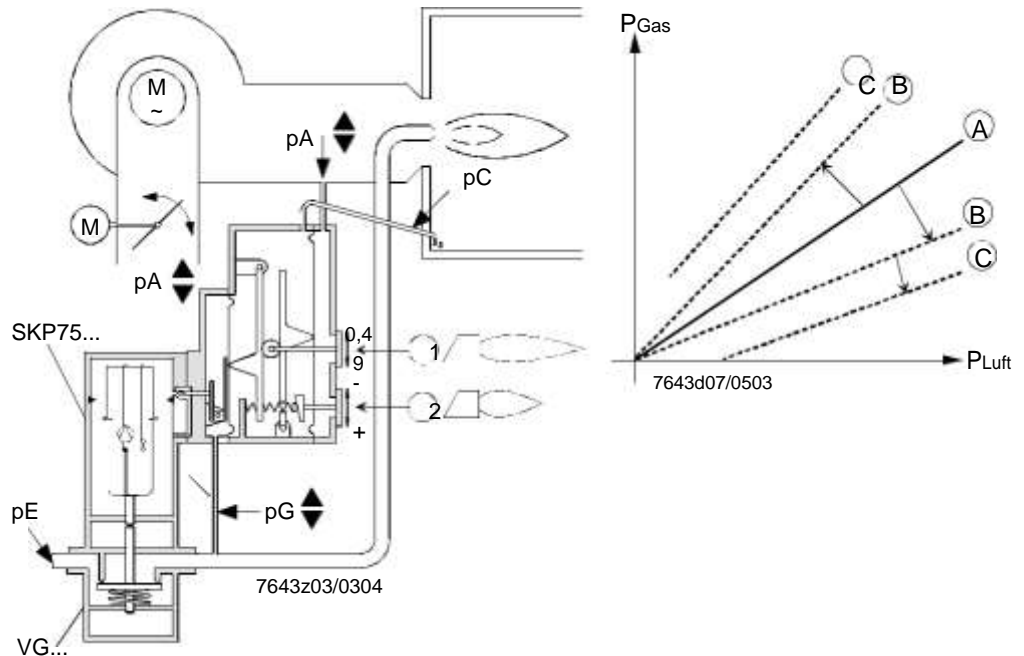

- $\mathcal{M}$  Setting and display of the gas / air ratio
- $\Omega$  Setting and display of parallel displacement of the working characteristic
- $\triangleleft$   $\rightarrow$  Test point for air pressure / Test point for combustion chamber pressure
- $\times$  Test point for gas pressure
- $\text{---}$  Stroke indication
- $\text{---}$  Operation indicator (LED)
- $\text{---}$  Gas valve

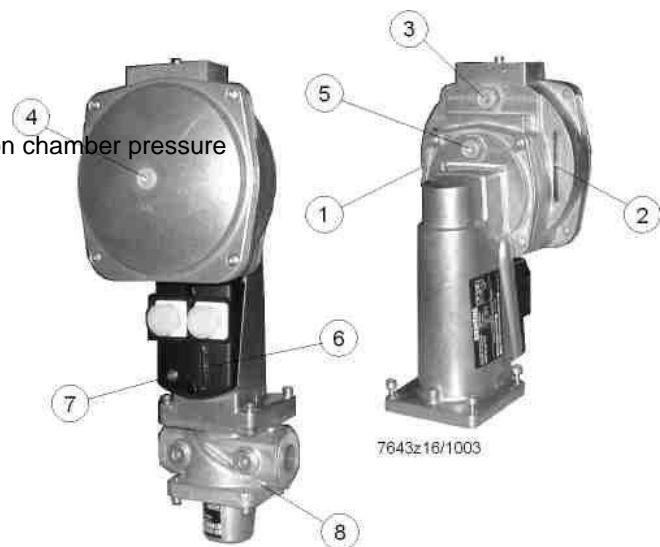

**Installation and commissioning notes (cont'd)**

Function If the air pressure exceeds the maximum value of

- 30 mbar with a P<sub>Gas</sub> / P<sub>Air</sub> ratio of  $\geq 2$
- 50 mbar with a P<sub>Gas</sub> / P<sub>Air</sub> ratio of  $\leq 2$

permitted for the governor, the pressure must be lowered with a reducing T-piece AGA78 (also refer to «Technical data»).

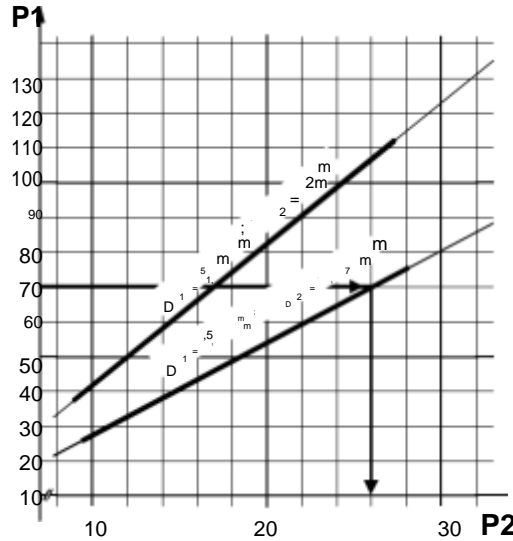

Example:  
 p<sub>1</sub> = 70 mbar  
 D<sub>1</sub> = 1.5 mm  
 D<sub>2</sub> = 1.7 mm

Wanted: Air pressure signal «p<sub>2</sub>» for the SKP75...  
 p<sub>2</sub> = 26 mbar

7643z02/0  
 50/2

Air is continuously vented to atmosphere via orifice «D2». The pressure of the following medium will be reduced via throttle «D1». The illustration below shows the correlations.

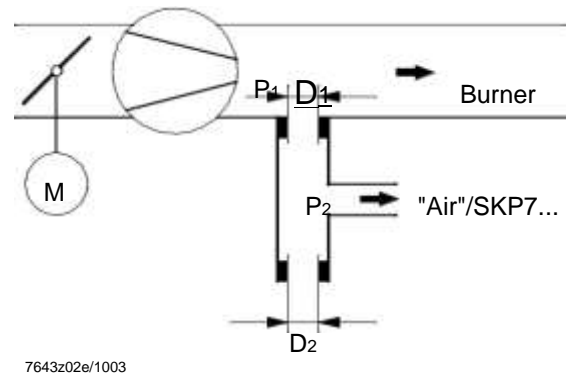
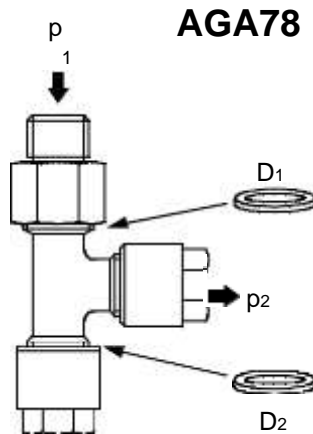

The reducing T-piece AGA78 is supplied ready for mounting, with D<sub>1</sub> = 1.5 mm and D<sub>2</sub> = 1.7 mm.  
 D<sub>2</sub> with a diameter of 2 mm is included as a loose item.

**Standards and certificates**



ISO 9001: 2000  
 Cert. 00739



ISO 14001: 2004  
 Cert. 38233



For use in the U.S. / Canada, the valves carry type suffix «U» (see example) and are -listed.

Example: SKP25.003U1

In connection with  
 valves

Conformity to EEC directives  
 – Electromagnetic compatibility EMC (immunity) 89 / 336 / EEC  
 – Directive for gas appliances 90 / 396 / EEC  
 – Directive for pressure devices 93 /23/EC

**Disposal notes**



The actuator contains electrical and electronic components and hydraulic oil and must not be disposed of together with domestic waste. Local and currently valid legislation must be observed.



**Type summary** (other types of actuators on request)

The complete gas shutoff assembly or pressure governor / controller assembly consists of actuator and valve.

SKP15...	<b>Mains voltage</b>	<b>AC 100...110 V</b>	<b>AC 220...240 V</b>
	1-stage opening and closing, without end switch	<b>SKP15.000E1</b>	<b>SKP15.000E2</b>
	1-stage opening and closing, with end switch	<b>SKP15.001E1</b>	<b>SKP15.001E2</b>
SKP25...	1-stage opening and closing, without end switch, with pressure governor up to 22 mbar	<b>SKP25.003E1</b>	<b>SKP25.003E2</b>
	1-stage opening and closing, with end switch, with pressure governor up to 22 mbar	<b>SKP25.001E1</b>	<b>SKP25.001E2</b>
	1-stage opening and closing, without end switch, zero governor version	<b>SKP25.303E1</b>	<b>SKP25.303E2</b>
	1-stage opening and closing, without end switch, with pressure governor up to 1,500 mbar, high-pressure version	<b>SKP25.403E1</b>	<b>SKP25.403E2</b>
	1-stage opening and closing, with end switch, with pressure governor up to 1,500 mbar, high-pressure version	<b>SKP25.401E1</b> <sup>1)</sup>	<b>SKP25.401E2</b> <sup>1)</sup>
	1-stage opening and closing, without end switch, for electric setpoint adjustment	---	<b>SKP25.703E2</b> <sup>1)</sup>
	1-stage opening and closing, with end switch, for electric setpoint adjustment	---	<b>SKP25.701E2</b> <sup>1)</sup>
1) On request			
SKL25...	1-stage opening and closing, without end switch, with pressure governor up to 22 mbar	---	<b>SKL25.003E2</b>
	1-stage opening and closing, with end switch, with pressure governor up to 22 mbar	<b>SKL25.001E1</b>	<b>SKL25.001E2</b>
SKP55...	1-stage opening and closing, without end switch, with differential pressure governor	<b>SKP55.003E1</b>	<b>SKP55.003E2</b>
	1-stage opening and closing, with end switch, with differential pressure governor	<b>SKP55.001E1</b>	<b>SKP55.001E2</b>
SKP75...	1-stage opening and closing, without end switch, with pressure ratio controller	<b>SKP75.003E1</b>	<b>SKP75.003E2</b>
	1-stage opening and closing, with end switch, with pressure ratio controller	<b>SKP75.001E1</b>	<b>SKP75.001E2</b>
	1-stage opening and closing, without end switch, with pressure ratio controller, with greater parallel displacement	<b>SKP75.503E1</b>	<b>SKP75.503E2</b>
	1-stage opening and closing, with end switch, with pressure ratio controller, with greater parallel displacement	<b>SKP75.501E1</b>	---

**Ordering examples**

When ordering, please give the complete type reference of the actuator (refer to «Type summary»). All products must be ordered as separate items.

Example of SKP15...

- Actuator
- On / off
- With end switch
- For AC 230 V / 50 Hz **SKP15.001E2**
- Connector valve actuator (plug) **AGA64**
- Connector end switch (plug) **AGA65**

The complete gas valve shutoff pressure governor assembly consists of actuator and valve. Please order the required valves as separate items (refer to the relevant Data Sheets). Actuator and valve are supplied unassembled. Assembly is very straightforward and preferably made on the burner.

Complete combination of actuator / valve consisting of:

- Gas valve
- SKP15.001E2 actuator
- Accessories

Example of SKP25...

- Gas pressure governor with safety shutoff feature:
- Without end switch **SKP25.003E2**
- For AC 230 V / 50 Hz
- Connector valve actuator (plug) **AGA64**

Combination of gas pressure governor / valve consisting of:

- Gas valve (refer to Data Sheets N7636 and N7631)
- SKP25.003E2 actuator
- Accessories, e.g. AGA25 (damping throttle)

**Accessories** (not supplied as standard, to be ordered as separate items)



**Heating element AGA63.5A27** refer to Data Sheet N7923  
 - For use at low ambient temperatures (< -10 °C)



**Connecting cable with plugs** **AGA62.000A000**  
 - For powering both actuators on the double valve (VGD...) with connector (AGA64)



**Connector for valve actuator** (power supply) **AGA64**  
 - Plug-in connector conforming to DIN EN 175301-803-A  
 - Triple pole +   
 - 6...9 mm dia. / max. 1.5 mm<sup>2</sup>











**Connector for end switch** **AGA65**  
 - Plug-in connector conforming to DIN EN 175301-803-A  
 - Triple pole +   
 - 4.5...11 mm dia. / max. 1.5 mm<sup>2</sup>



**Motorized setpoint adjuster** for use with SKP25.7... **SQS37**  
 - 35 s  
 - For 5.5 mm stroke  
 - Refer to Mounting Instructions M7643.3  
 - Refer to Data Sheet SQS35... N4573

**Accessories** (not supplied as standard, to be ordered as separate items)

	<b>Setpoint spring</b> (yellow) for SKP25... - Optional to standard spring AGA29 - 15...120 mbar - Standard spring in SKP25.4... (0...700 mbar)	<b>AGA22</b>
	<b>Setpoint spring</b> (red) for SKP25... - Optional to standard spring AGA29 - 100...250 mbar - 0...1,500 mbar with SKP25.4... (optional to AGA22)	<b>AGA23</b>
	<b>Setpoint spring</b> (unpainted) for SKP25.3... and SKP55... - Optional to standard spring AGA29 - ±1.5 mbar	<b>AGA28</b>
	<b>Setpoint spring</b> (unpainted) for SKP25... - 0...22 mbar	<b>AGA29</b>
	<b>Damping throttle</b> for SKP25... - Optional	<b>AGA25</b>
	<b>Damping throttle</b> for SKP55... - Optional, pipe connection for 8 mm dia. - Refer to Mounting Instructions 4 319 2078 0	<b>AGA75</b>
	<b>Damping throttle</b> for SKP55... - Optional (Same as AGA75 but with ¼" threaded connection on both sides)	<b>AGA75E</b>
	<b>Pressure reducing-T-piece</b> for SKP75... - Optional	<b>AGA78</b>
	<b>Set of gaskets</b> - For use between actuator and valve - Increases degree of protection from IP 54 to IP 65 - When using VGG...single valves, also observe Data Sheet N7636 - Refer to Mounting Instructions M7643.2 - On request	<b>AGA66</b>

**Technical data**

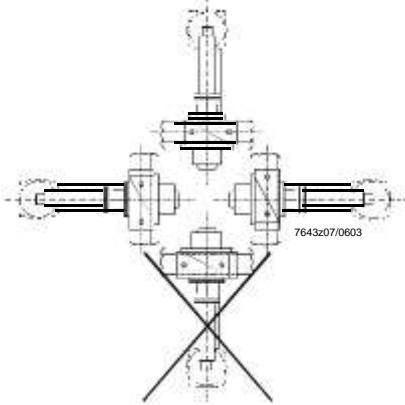
General device data	Mains voltage	AC 220 V –15 %...AC 240 V +10 % AC 100 V –15 %...AC 110 V +10 %	
	Mains frequency	50...60 Hz ±6 %	
	Power consumption	max. 13.5 VA	
	End switch (if fitted)	factory set as closed position switch valve fully closed	
	- Switching capacity	4 (2 A, cosφ = 0.3)	
	On time	100 %	
	Opening time for full stroke	6...10 s (depending on nominal valve size) (longer opening times below 0 °C)	
	Opening speed (approx. 2 mm / s)	lower opening speeds due to low ambient temperatures can be compensated by fitting an AGA63.5A27 heating element	
	Closing time		
	- SKP...	< 0.8 s (in the event of power failure)	
	- SKL25...	3...6 s (depending on the type of valve)	
	Perm. mounting positions		
			
		always with the diaphragms in the vertical position	
Degree of protection	IP 54 → only ensured when central screw at the connector is tightened		
Stroke	max. 26 mm (valve limits max. stroke)		
Weight			
- SKP15...	approx. 1.1 kg		
- SKP25...	approx. 1.6 kg		
- SKP25.7...	approx. 1.6 kg (without SQS37)		
- SKL25...	approx. 1.6 kg (without SQS37)		
- SKP55...	approx. 1.9 kg		
- SKP75...	approx. 2.3 kg		
Perm. media	depending on the type of valve		
Medium inlet pressure «PE»	depending on the type of valve		
Perm. medium temperature	depending on the type of valve		
Flow rate	depending on the type of valve		
Perm. test pressure «PG»	1,000 mbar		
Perm. underpressure «PG»	200 mbar		

**Technical data (cont'd)**

Environmental conditions	<b>Storage</b>	DIN EN 60 721-3-1
	Climatic conditions	class 1K3
	Mechanical conditions	class 1M2
	Temperature range	-10...+60 °C
	Humidity	< 95 % r.h.
	<b>Transport</b>	DIN EN 60 721-3-2
	Climatic conditions	class 2K2
	Mechanical conditions	class 2M2
	Temperature range	-10...+60 °C
	Humidity	< 95 % r.h.
	<b>Operation</b>	DIN EN 60 721-3-3
	Climatic conditions	class 3K3
	Mechanical conditions	class 3M3
Temperature range	-10...+60 °C (longer opening times below 0 °C) -20...+60 °C (with heating element AGA63...)	
Humidity	< 95 % r.h.	
 <b>Condensation, formation of ice and ingress of water are not permitted!</b>		
SKP25...	Setpoint range of outlet pressure	0.5...250 mbar (3 setpoint springs, refer to «Accessories»)
	Control class	A to DIN EN 88
	Setting range (setpoint)	max. 250 mbar (gas pressure)
	Control group	III to DIN 3392
SKP25.3...	Combustion air pressure	max. 50 mbar
	Zero governor	to EN 12067-1
	Compensating variable	differential pressure of combustion air ≥ 0.5 mbar
	Differential pressure ratio (gas / air)	1:1
	Parallel displacement	P <sub>Gas</sub> ±1 mbar
SKP25.7...	Setpoint ranges $\Delta w_o / \Delta w_u$	refer to «Function diagram»
	Temperature range in operation	-5...+50 °C (limited by SQS37)
SKP55...	Differential pressure ratio (gas / air)	1:1
	Perm. differential pressure the controller may be subjected to during operation	$\Delta$ 0.3...200 mbar
	Control accuracy	< 10 % at « $\Delta p_{min}$ » < 1 % at « $\Delta p_{max}$ »
	Parallel displacement of working characteristic	
	- Excess gas	1 mbar
	- Excess air	1 mbar
	Compensating variable	differential pressure of combustion air ≥ 0.3 mbar
	Interval required for load change via air damper, from high-fire to low-fire	min. 5 s (depending on valve stroke)

**Technical data (cont'd)**

SKP75...	Control accuracy	< 10 % at « $\Delta p_{min}$ » < 2 % at « $\Delta p_{max}$ »
	Control group	III to DIN 3392
	Control variable «Gas pressure»	differential pressure «PG-PF» or «PG-PAir» min. 0.8 mbar max. 120 mbar
	Control class	A to DIN EN 88
	Compensating variable	combustion air; when connecting combustion chamber pressure, differential pressure of «Pair – Pcombustion chamber» > 0.5 mbar
	Air pressure at «PGas/PAir»	
	- $\geq 2$	max. 30 mbar
	- $\leq 2$	max. 50 mbar
	- for higher pressures, see AGA78 (accessory)	max. 150 mbar
	Setting range pressure ratio	refer to «Type summary»
	- «P <sub>gas</sub> / P <sub>Air</sub> »	0.4...9
	Parallel displacement of working characteristic	
	- Excess gas	1 mbar
	- Excess air	1 mbar
	- Excess with SKP75.5...	4.5 mbar
	Perm. combustion chamber pressure	depending on the controlled variable gas pressure «PG»
	Recommended distance impulse pipe connection from valve	min. 5 x nominal valve size at a location where there is no turbulence
	Inlet pressure	same as valve
	Perm. test pressure «PG»	1 bar
	Perm. underpressure «PG»	200 mbar
Interval required for load change via air damper, from high-fire to low-fire	min. 5 s (depending on valve stroke)	
<b>Motorized setpoint adjuster SQS27...</b>	Mains voltage (control voltage)	AC230V+10%/-15%
	Mains frequency	50...60 Hz $\pm 6$ %
	Power consumption	2.5 VA
	Running time $\Delta t_{\Delta w_{om}}$	5.5 mm / 35 s
	Degree of protection	IP 54
	Safety class	III to VDE 0631
Environmental conditions	<b>Storage</b>	DIN EN 60 721-3-1
	Climatic conditions	class 1K3
	Mechanical conditions	class 1M2
	Temperature range	-5...+50 °C
	Humidity	< 95 % r.F.
	<b>Transport</b>	DIN EN 60 721-3-2
	Climatic conditions	class 2K3
	Mechanical conditions	class 2M2
	Temperature range	-25...+70 °C
	Humidity	< 95 % r.F.
	<b>Operation</b>	DIN EN 60 721-3-3
	Climatic conditions	class 3K5
	Mechanical conditions	class 3M3
	Temperature range	-5...+50 °C
	Humidity	< 95 % r.F.

**Condensation, formation of ice and ingress of water are not permitted!**

**Contact assignment device connector**



Valve actuator  
 Connector AGA64  
 DIN EN 175301-803-A  
 double pole +

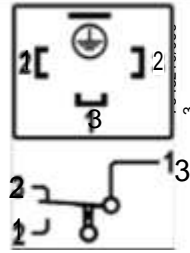

End switch  
 Connector AGA65  
 DIN EN 175301-803-A  
 triple pole +

← Valve closed

**Dimensions**

Dimensions in mm

SKP15.000... actuators

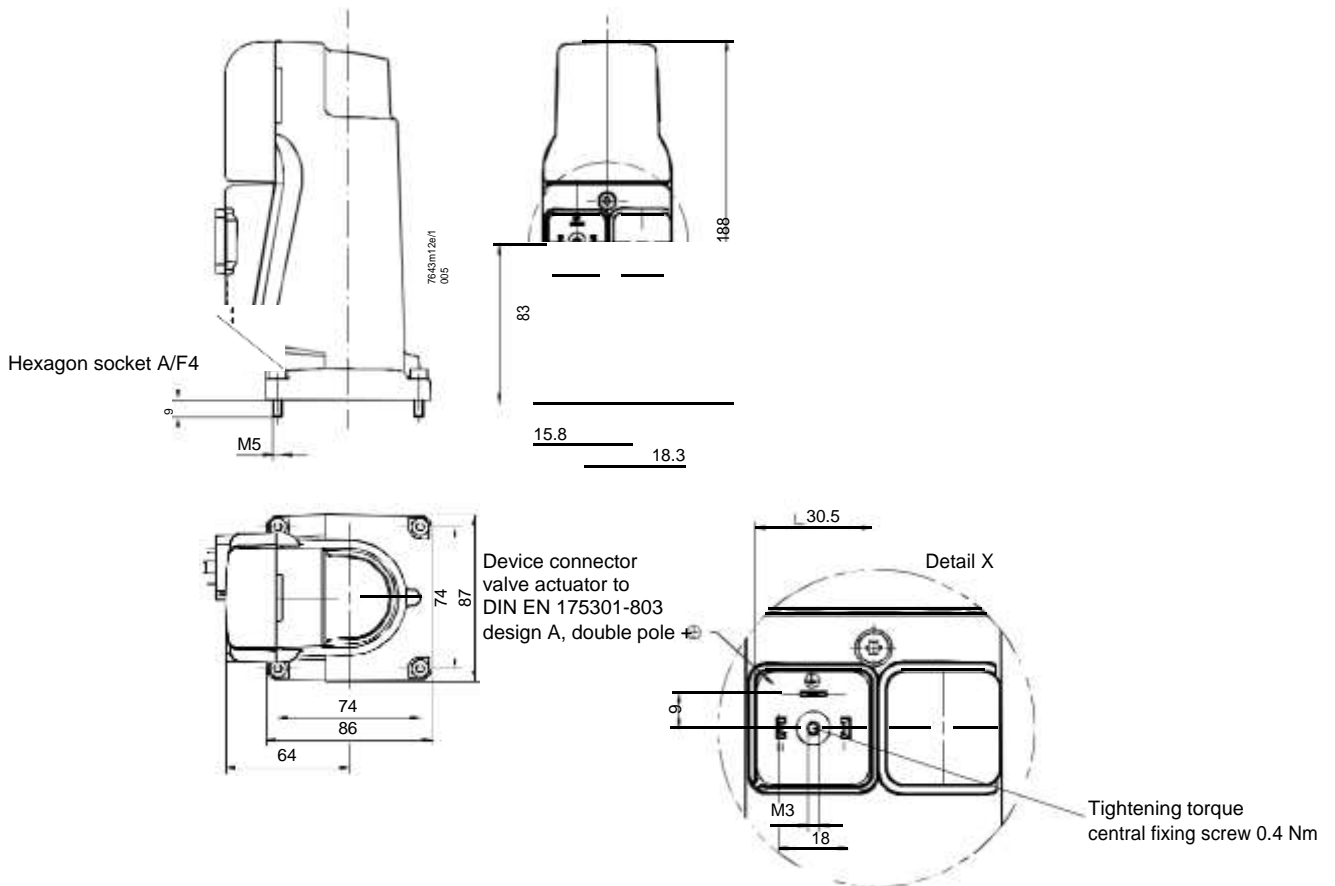

**Dimensions (cont'd)**

Dimensions in mm

Actuator SKP15.001...

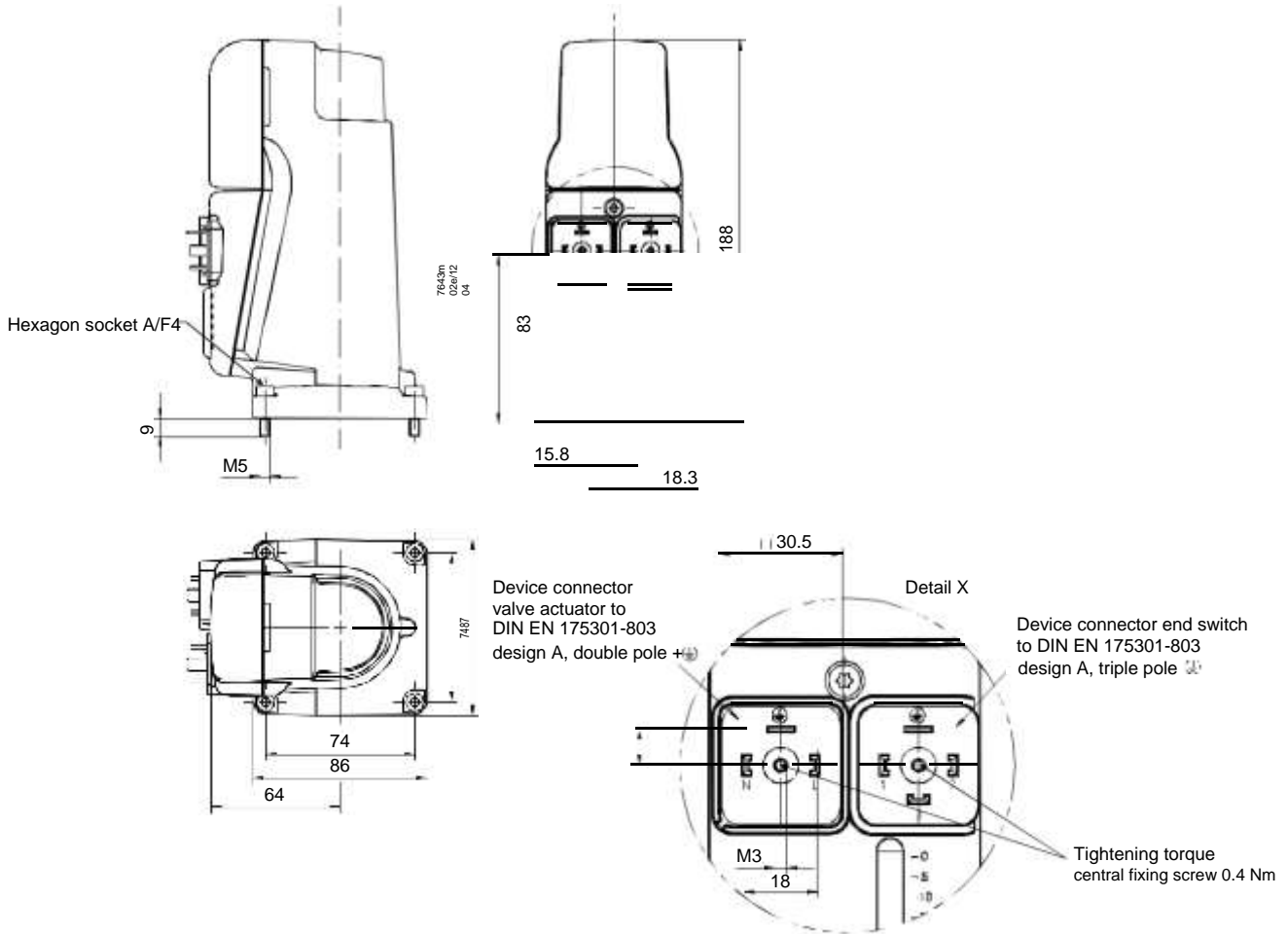



**Dimensions (cont'd)**

Dimensions in mm

Actuators SKP25.0... /  
 SKP25.3... / SKL25...

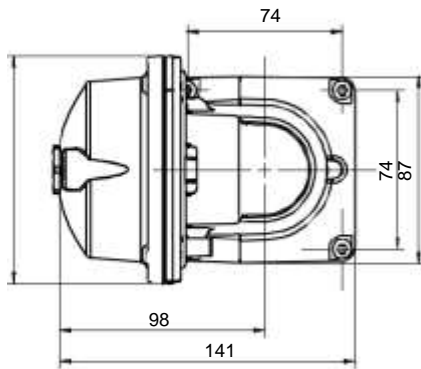
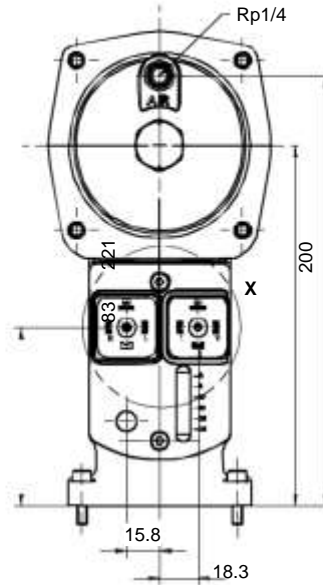
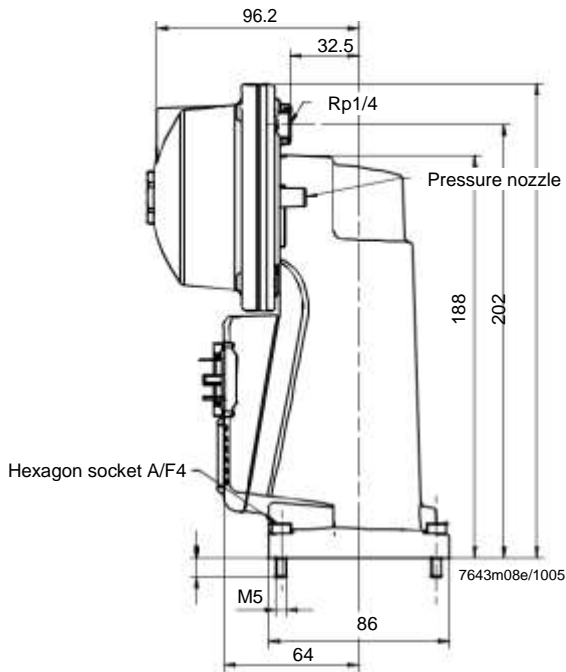

Device connector  
 valve actuator to  
 DIN EN 175301-803  
 design A, double pole +

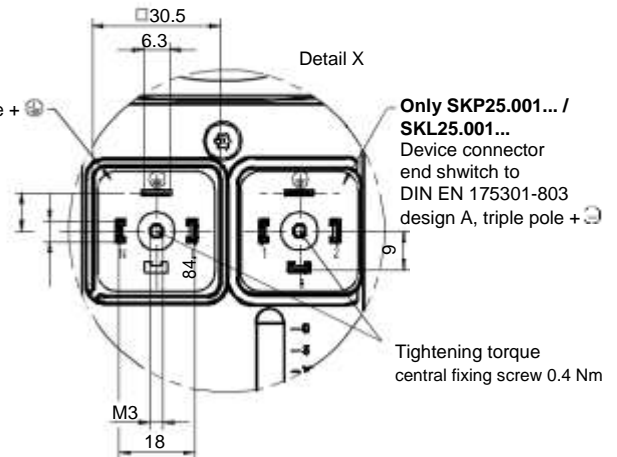

**Dimensions** (cont'd)

Dimensions in mm

Actuators SKP25.4...

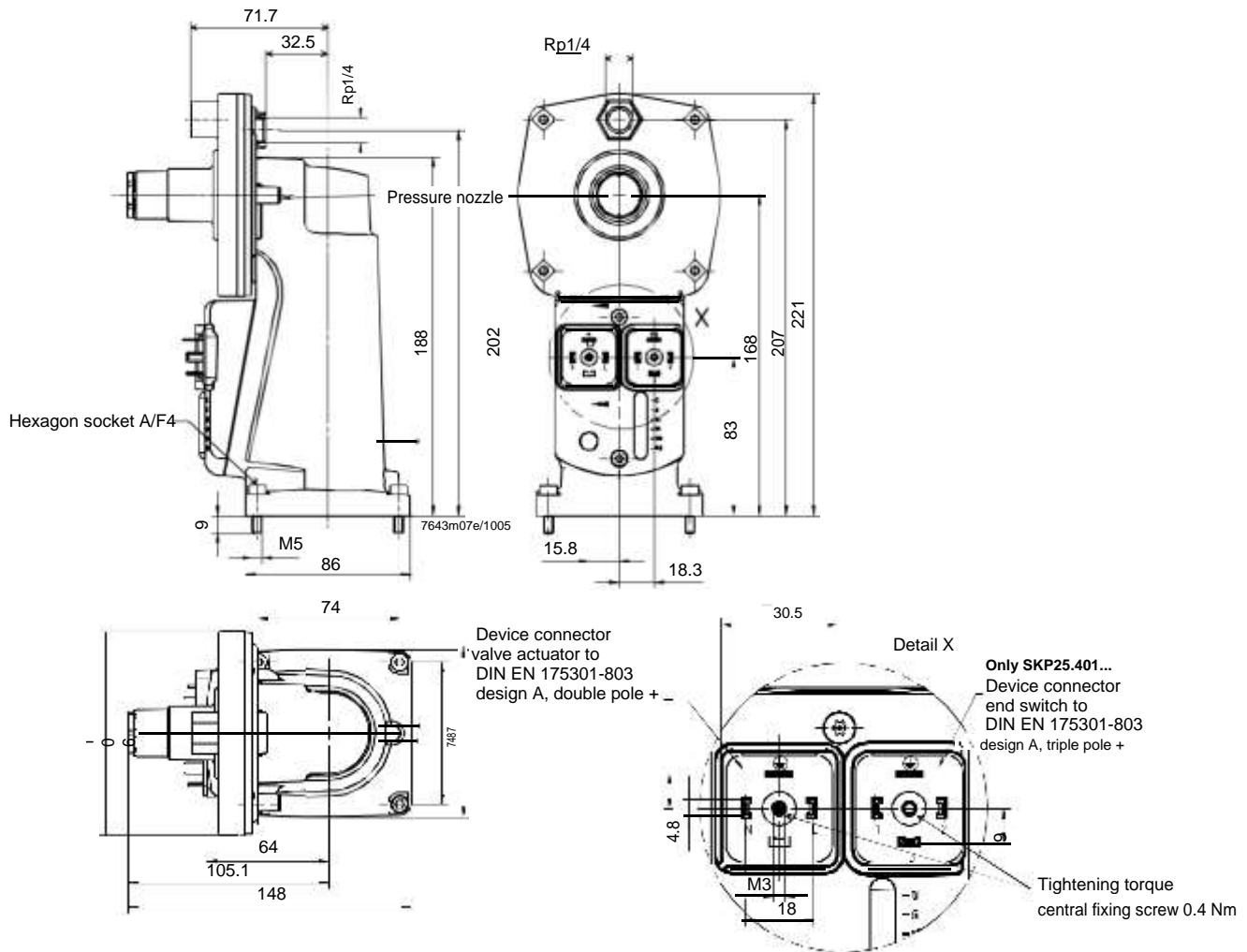

**Dimensions (cont'd)**

Dimensions in mm

Actuator SKP25.7...  
 without SQS37  
 motorized setpoint  
 adjuster

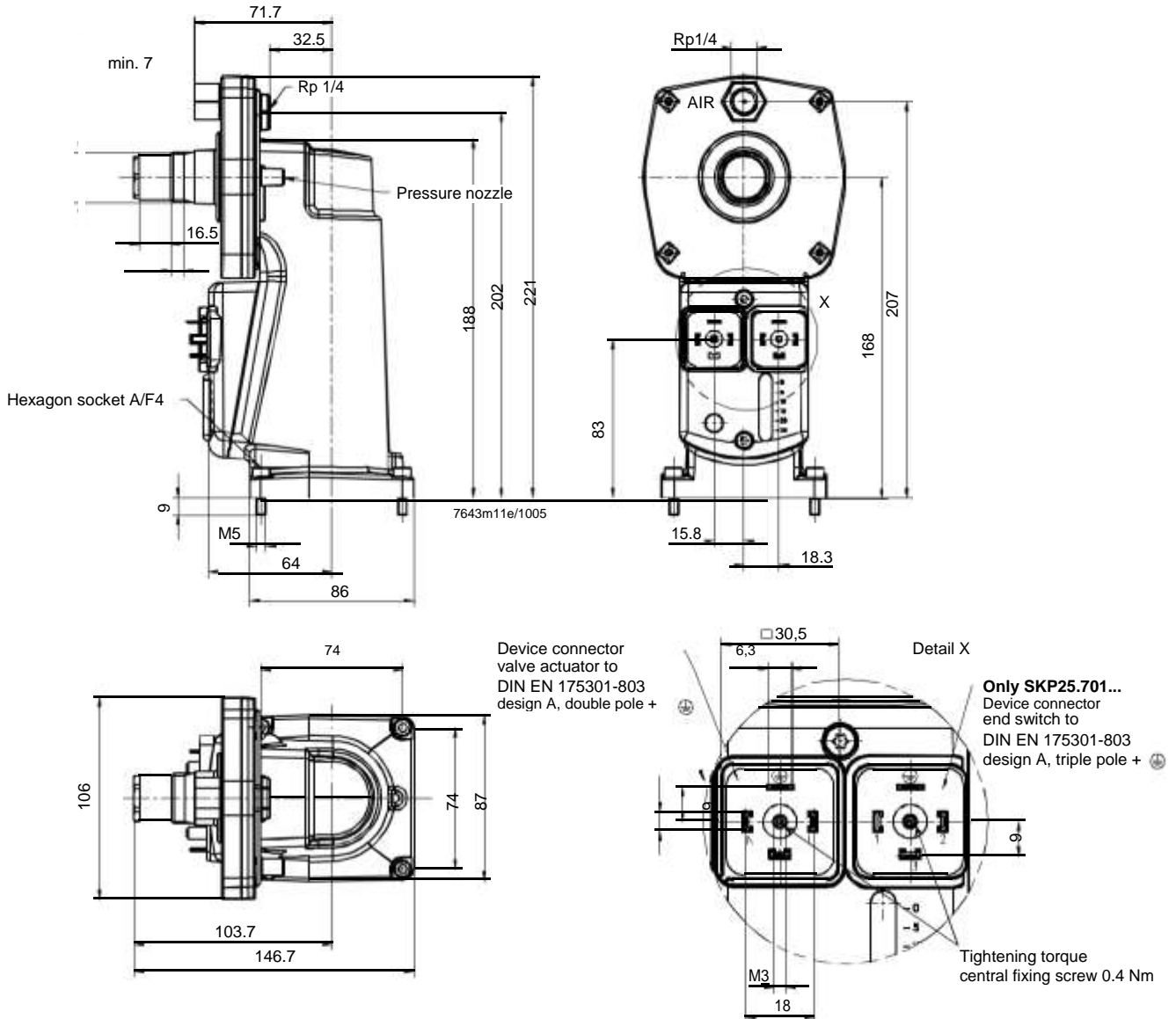

**Dimensions (cont'd)**

Dimensions in mm

Actuators SKP55...

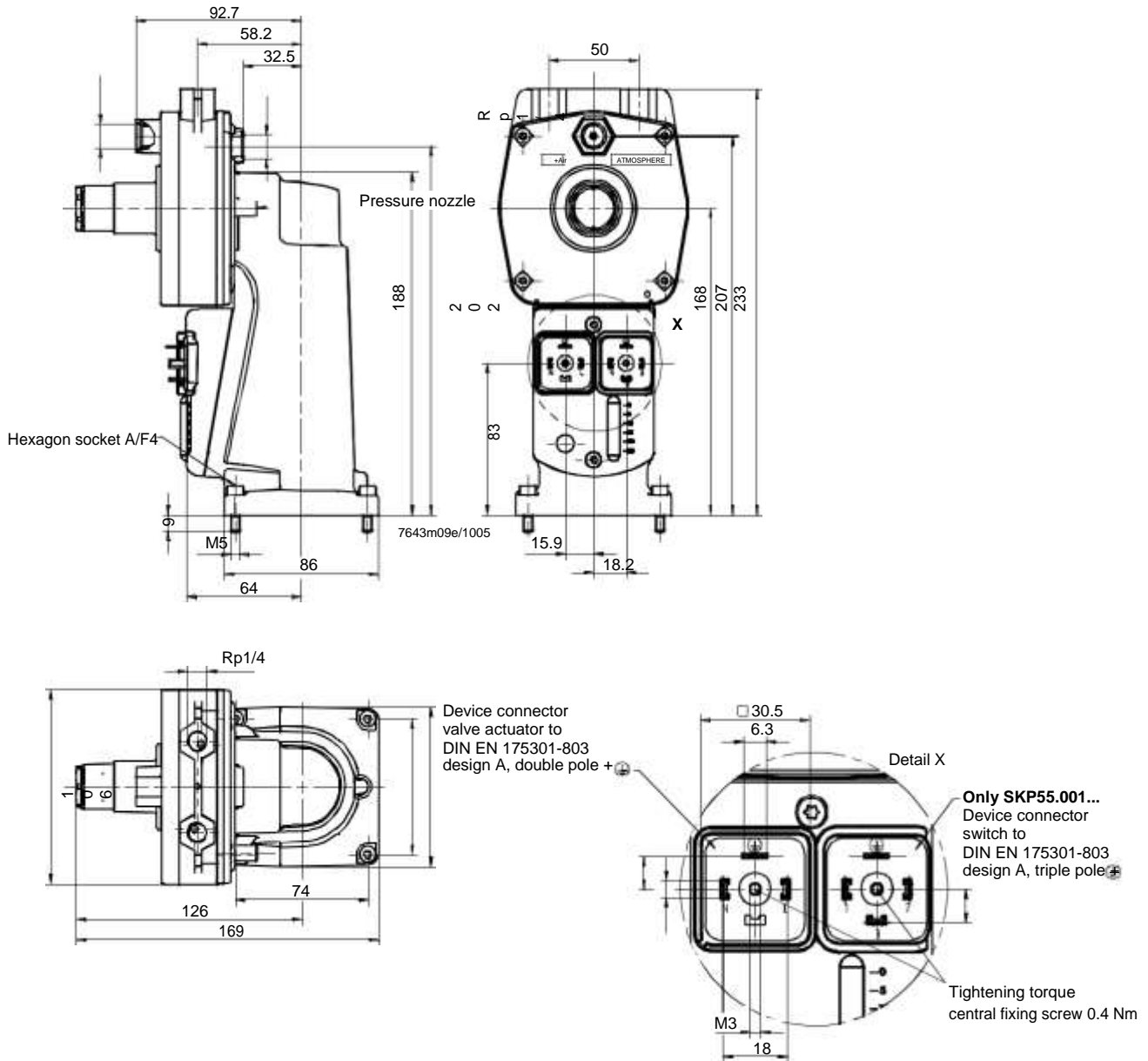

**Dimensions (cont'd)**

Dimensions in mm

Actuators SKP75...

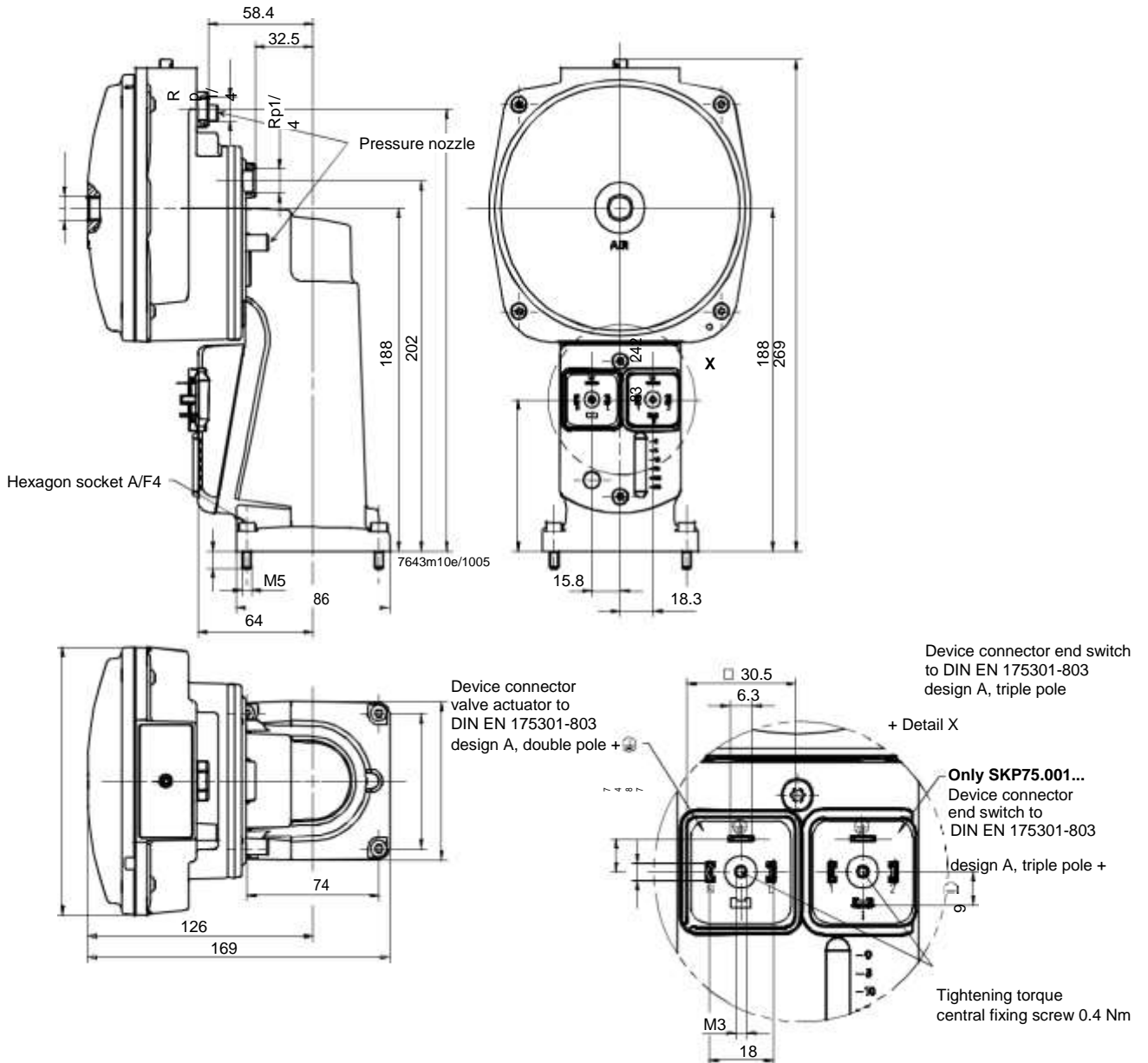

**Dimensions (cont'd)**

Dimensions in mm

Connecting cable  
 AGA62.000A000

- For 2 actuators mounted on a valve

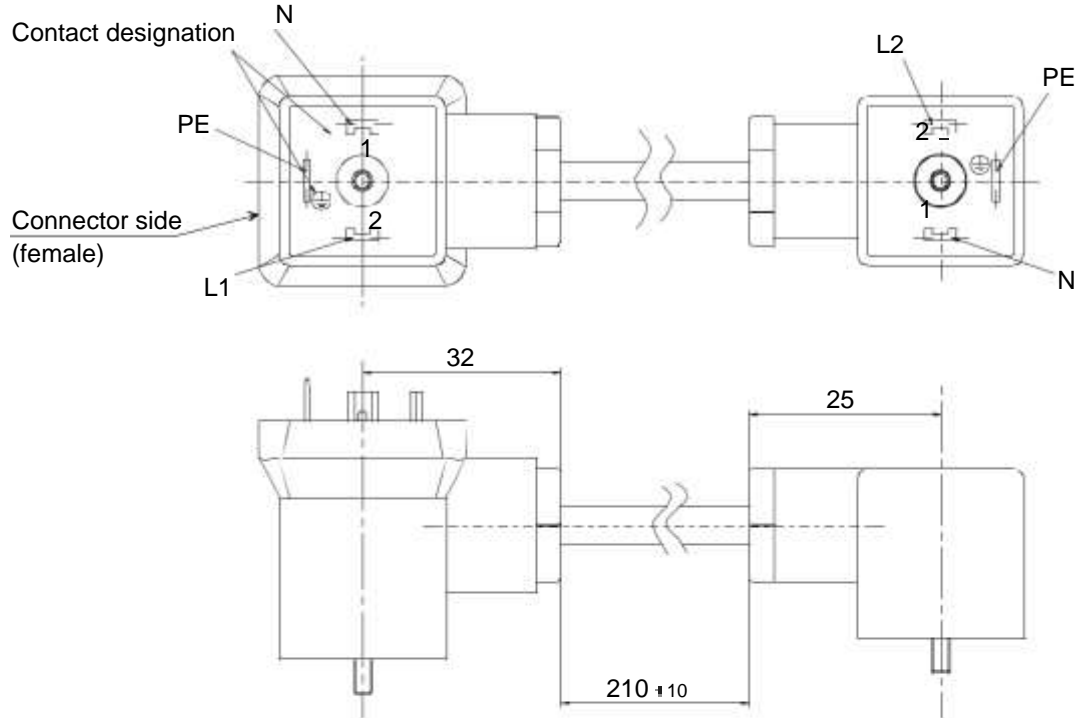

Tightening torque  
 central fixing screw 0.4 Nm

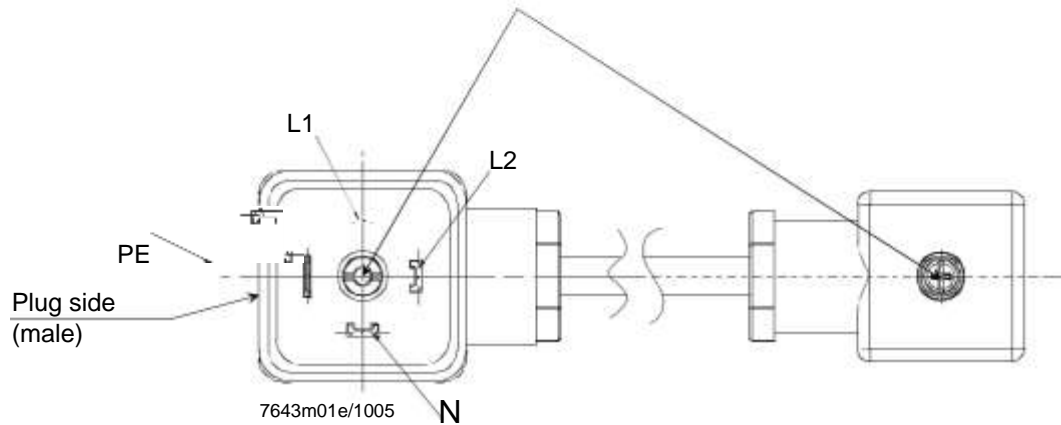

Connection diagram

