



SIEMENS

7<sup>813</sup>



## Actuators for air dampers and gas dampers

SQM33...

### Electromotoric actuators

- **Torques:**
  - SQM33.4... up to 1.2 Nm nominal output torque
  - SQM33.5... up to 3 Nm nominal output torque
  - SQM33.7... up to 10 Nm nominal output torque  
self-holding torque  
(refer to «Type summary»)
- **Running times for 90°:**
  - SQM33.4... 5 seconds
  - SQM33.5... 5 seconds
  - SQM33.7... 17 seconds
- **Versions:** Choice of cables (refer to «Type summary»)

The SQM33... and this Data Sheet are intended for use by OEMs which integrate the actuators in their products!

### Use

The actuators SQM33 are suited for driving oil pressure controllers, butterfly valves, dampers or for use on other applications that require rotary motion.  
Areas of application are oil and gas burners of medium to larger capacity.

The actuators are used primarily for the load-dependent control of the flow of gas, oil volume, and combustion air volume in connection with the electronic ratio control LMV27 / LMV37.



## Supplementary documentation

Product type	Type of documentation	Documentation number
LMV27.100x2	Basic Documentation	P7541
LMV37.400x2	Basic Documentation	P7546
AZL2...	Data Sheet	N7542

## Warning notes



To avoid injury to persons, damage to property or the environment, the following warning notes must be observed!

**Do not open, interfere with or modify the actuators!**

Read the documentation on the actuators carefully and fully. If not observed, dangerous situations can occur

The user must ensure that the actuators meet the requirements of the relevant application standards

All product-related activities (mounting, settings and maintenance) must be performed by qualified and authorized personnel

**Notice!**

- **Risk of electric shock hazard – to disconnect the equipment from the power, it may be necessary to open more than one switch. Before performing maintenance work, the equipment must be disconnected from power**
- **The electrical connection between the conduit fittings is not made automatically. It must be established on installation site**
- **The connecting plate is made of plastic and does not provide earthing of the conduit fittings. Earthing must be ensured with adequate washers and wire links**

- Ensure protection against electric shock hazard by providing adequate protection for the connection terminals and by securing the housing cover
- To ensure protection against electric shock, the connection terminals must have adequate protection. Make certain that noninsulated connections or wires cannot be touched
- Each time work has been carried out (mounting, installation, service work, etc.), check to ensure that wiring is in an orderly state
- Fall or shock can adversely affect the safety functions. Such units must not be put into operation, even if they do not exhibit any damage
- The notes in chapter *Section of actuator version, Positive connection and Unambiguous assignment* must be observed, for safeguarding of correct fuel / air ratio
- Static charges must be avoided since they can damage the electronic components on contact.

**Recommended:** Use ESD equipment

Housing cover

**Caution!**

**The actuator's housing must not be opened. The actuator contains an optical feedback system.**

## Notes on use in North America

Only flexible conduits with relevant accessories may be used.



### Selection of actuator version

- Select the type of actuator depending on the torque required for driving the controlling element
- Ensure that any other torque acting on the controlling element (e.g. torque due to the airflow produced by the burner's fan) is smaller than the actuator's self-holding torque when power not applied
- The mechanical design of the burner must be such that any inadmissibly high torque from outside acting on the controlling element will not lead to critical burner operation.

**Example:**

The airflow in the burner's air duct exerts a torque on the air damper's asymmetrical bearing so that the air damper will slightly travel towards the fully open position. This leads to a certain amount of excess air in the combustion process, which is less critical than lack of air



## Mounting notes

Ensure that the relevant national safety regulations are complied with and standard notes

- In the geographical areas where DIN regulations are in use, the requirements of VDE must be satisfied, especially DIN/VDE 0100, 0550 and DIN/VDE 0722
- Make certain that the actuator is not exposed to direct solar radiation
- The connection between actuator drive shaft and controlling element must be form-fitted (no mechanical play permitted)
- When mounting the actuator, ensure that the permissible axial and radial load acting on the bearing will not be exceeded
- When fitting the actuator to the controlling element, proceed as follows:
  1. Fit and secure the actuator.
  2. Connect the actuator's drive shaft to the controlling element by means of a coupling pin.

### Positive connection

#### Caution!

##### Possible connection with drive shaft or hub:

- Drive shaft with flat edge and matching counter piece

To avoid inadmissible loads on the bearing caused by rigid coupling hubs, Siemens recommends using compensating coupling without mechanical play (e.g. metal bellows coupling).



- When sizing a drive shaft connection, consider that – during operation – the effective torque can exceed the actuator's rated torque:
  - Under optimum operating conditions, the actuator may deliver a higher torque
  - Mass moments of inertia (produced by rotating motor components and on the controlling element) can lead to sudden peak loads
- Siemens AG recommends to adequately oversize the drive shaft connection in relation to the actuator's rated torque
- The connection between actuator and burner or controlling element must be very rigid (no bending). This is of particular importance when using structures incorporating columns

### Unambiguous assignment



#### Caution!

To prevent mix-up of actuators connected to the LMV2... / LMV3..., these types of burner controls carry various reference marks.

The burner must be designed such that, in the event of false connections, the relevant reference mark cannot be approached.

For that purpose, mechanical stops are to be provided in the range «Stop open» and «Stop closed».

### Cable

#### SQM33.41... / SQM33.51... / SQM33.71...:

The actuators are supplied complete with attached connecting cable and plug

#### SQM33.550A9 / SQM33.750A9:

The actuators are supplied with cable ready connected, complete with ferrules

The 6-poles RAST2.5 / RAST3,5 connecting plug (included in scope of delivery)

One-time bend when laying the cable: 2 x cable diameter



**Mounting notes (cont'd)**

IP54

To ensure degree of protection IP54 over the actuator's entire service life, the bearing of the drive shaft must be located such that it will not be directly exposed to water or dust.

Mounting example

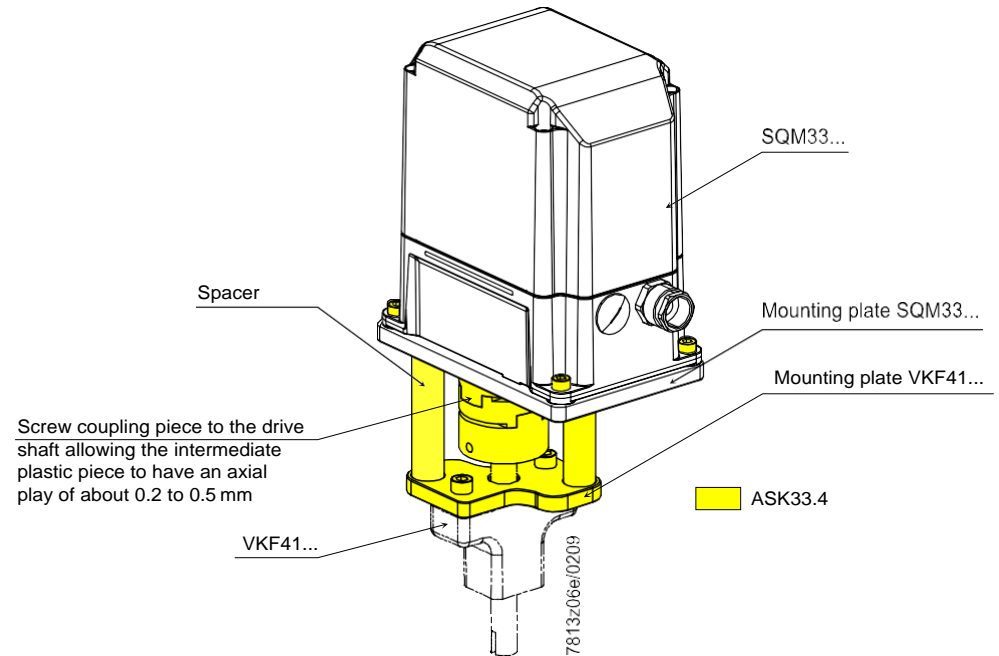



Mounting notes (cont'd)

Working range of actuator

The actuator's working range consists of usable range and reference range. The usable range is specified on the type field. When mounting the actuator, the connected controlling element (e.g. air damper) must allow travel both in the reference range and the adjusted usable range. Reference ranges «Open» and «Close» differ. In the case of an actuator with **counterclockwise** direction of rotation, reference range «Close» lies between 0° and -7.7°, and reference range «Open» between 90° and 110.6°. To ensure precise positioning of the actuator on the burner, a positioning pin of 6 mm dia. must be fitted to the mounting surface (refer to detail A under «Dimensions»).

Direction of rotation: **Counterclockwise**

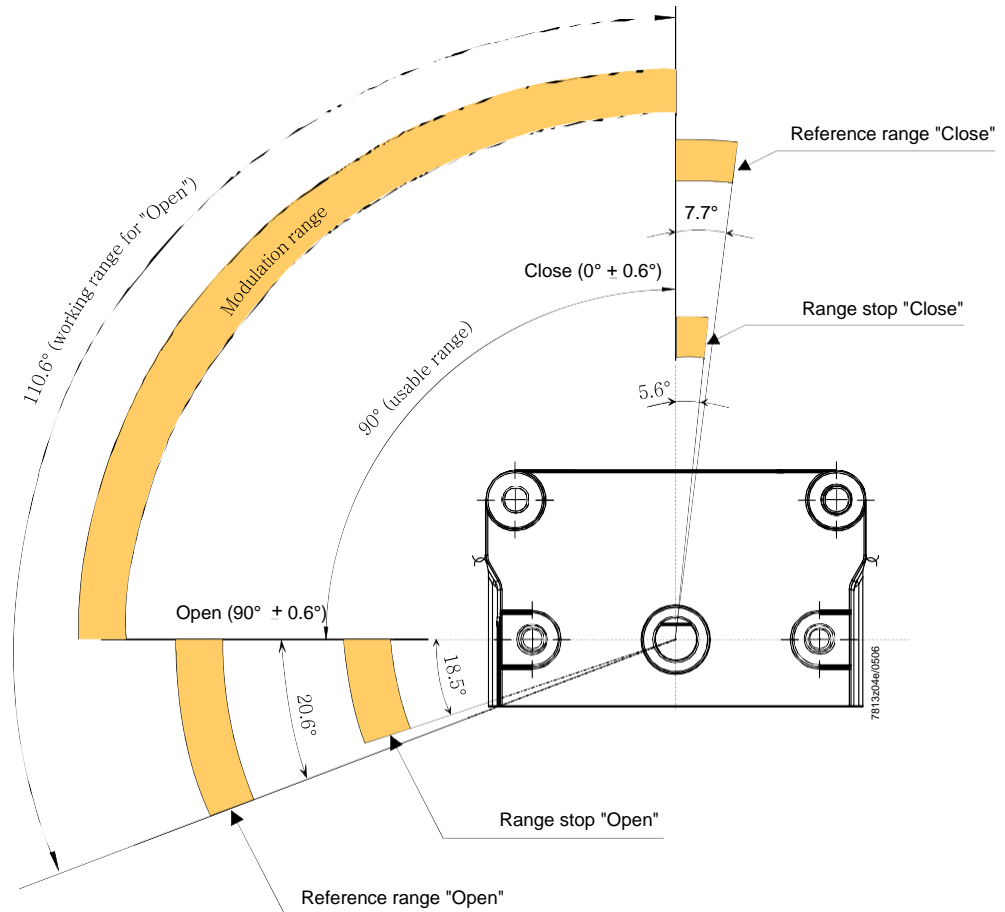

## Mounting notes (cont'd)

Direction of rotation:  
**Clockwise**

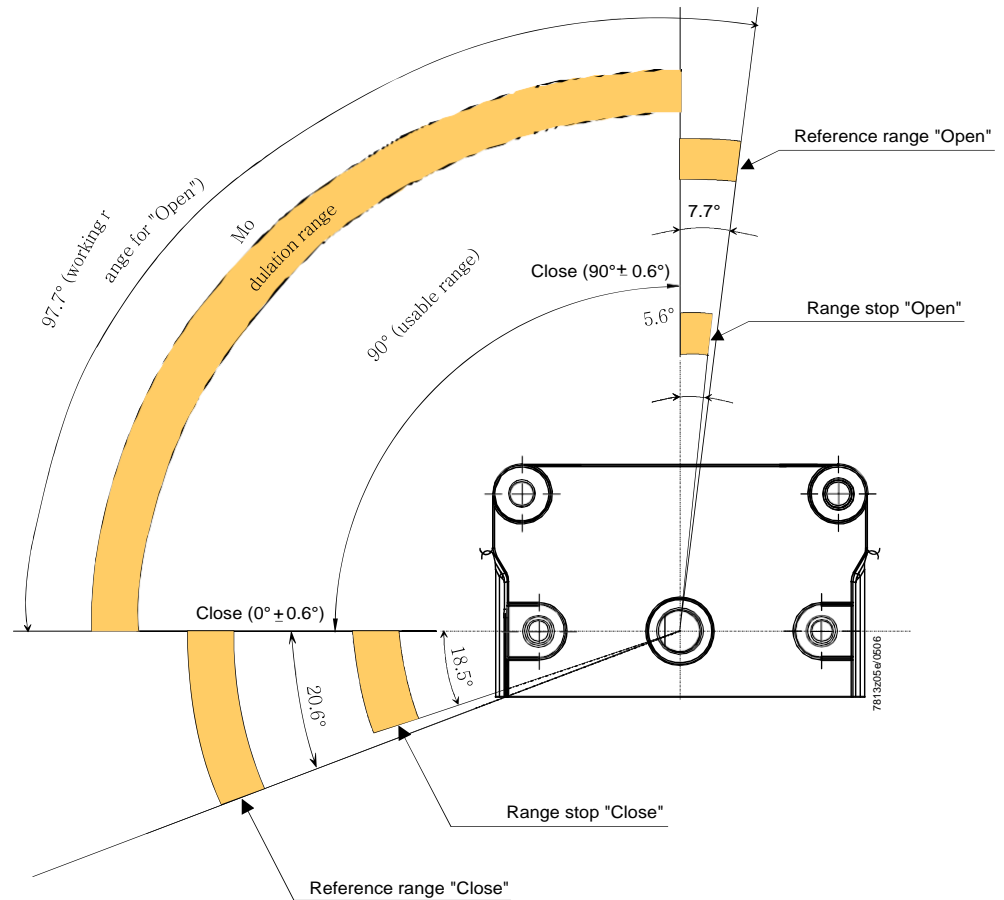

## Installation notes

- Make certain that strain relief of the connected cables is in compliance with the relevant standards (e.g. in accordance with DIN EN 60730 and DIN EN 60335)
- The connection between the actuator drive shaft and the relevant controlling element must be form-fitted
- Always run the high-voltage ignition cables separate from the unit and other cables while observing the greatest possible distance
- The holding torque is reduced when the actuator is disconnected from power



บริษัท เอดีดี เฟอร์เนส จำกัด

ADD FURNACE CO.,LTD.

44 ซอยบรมราชชนนี 70 ถนนบรมราชชนนี แขวงศาลาธรรมสพน์ เขตทวีวัฒนา กรุงเทพฯ 10170

โทร: 02-888-3472 โทร: ออกแบบ:08-08-170-170 แฟกซ์: 02-888-3258

https://www.add-furnace.com E-mail: sales@add-furnace.com

## Standards and certificates



Note!

Only in conjunction with the basic unit LMV2... / LMV3... (see Basic Documentation LMV2... → P7541 / LMV3... → P7546).



EAC Conformity mark (Eurasian Conformity mark)



ISO 9001:2008  
ISO 14001:2004  
OHSAS 18001:2007

1)



1) The CSA approval does not apply for SQM33.7



China RoHS

Hazardous substances table:

<http://www.siemens.com/download?A6V10883536>

## Service notes

### Replacement

When replacing an actuator, the following points must be checked and, if necessary, corrected:

Correct connection of the basic unit

Assignment of functions

Adjustment of curve points of electronic fuel / air ratio control (e.g. with the LMV27.100x2)

## Lifetime

The actuator has a designed lifetime\* of 250,000 start cycles (OFF ⇒ ON ⇒ OFF) under load with the rated torque in the entire rotation angle range, which under normal operating conditions in heating mode corresponds to approx. 10 years of service (starting from the production date given on the type field). This is based on the endurance tests specified in the standard EN 298.

A summary of the conditions has been published by the European Control Manufacturers Association (Afecon) ([www.afecor.org](http://www.afecor.org)).

The lifetime is based on use of the actuator according to the manufacturer's data sheet. After reaching the designed lifetime in terms of the number of burner startup cycles, or after the corresponding usage time, the actuator is to be replaced by authorized personnel.

\* The designed lifetime is not the warranty time specified in the Terms of Delivery.

## Disposal notes



The actuator contains electrical and electronic components and must not be disposed of together with domestic waste.

Local and currently valid legislation must be observed.





## Mechanical design

---

Housing	<p>Die-cast aluminum lower housing. Housing cover made of impact-proof and heat-resistant plastic.</p> <p>SQM33.550A9 / SQM33.750A9 has a flange for the connection of a Conduit connecting thread (NPSM 1/2"-14).</p> <p>Color of cover: Black</p>
Drive motor	Stepper motor
Adjustment of switching points / position indication	In connection with the basic unit (e.g. LMV27.100x2): Via the AZL2... display and operating unit (refer to the Basic Documentation of the LMV27.100x2 (P7541)).
Cable / electrical connections	<p>SQM33.41xA9 and SQM33.51xA9 / SQM33.71xA9 only: RAST2.5 connectors complete with cable.</p> <p>SQM33.550A9 / SQM33.750A9 only: Cable with ferrules, RAST2.5 / RAST3.5 connector (included in scope of delivery).</p>
Gear train	Spur gears made of steel and plastic, with little backlash and permanent lubrication.
Drive shaft	Made of black-finished steel, ready fitted to the front of the gear train.
Mounting and fixing	The front of the gear train is used as the mounting surface. The actuator has 4 fixing holes and an elongated hole for the positioning pin. Alternatively, the actuator can be secured with 3 self-tapping screws from the side of the controlling element.

**Type summary**

## Actuators SQM33...

Article no.	Type	Rated output torque (max.) Nm	Holding torque when power applied (max.) Nm	Holding torque when power not applied (max.) Nm	Cable length m	Radial load on bearing middle of driveshaft (max.)	Axial load <sup>1)</sup> on bearing middle of drive shaft (max.) N
BPZ:SQM33.410A9	SQM33.410A9	1.2	1.2	0.8	1.5	100	10
BPZ:SQM33.411A9	SQM33.411A9	1.2	1.2	0.8	3	100	10
BPZ:SQM33.510A9	SQM33.510A9	3	3	2.6	1.5	100	10
BPZ:SQM33.511A9	SQM33.511A9	3	3	2.6	3	100	10
BPZ:SQM33.550A9	SQM33.550A9	3	3	2.6	3.6	100	10
BPZ:SQM33.711A9	SQM33.711A9	10 <sup>1)</sup>	10	6	3	100	10
BPZ:SQM33.750A9	SQM33.750A9	10 <sup>1)</sup>	10	6	3.6	100	10

<sup>1)</sup> For ambient temperatures below 0°: Approx 10 % torque reduction

**Accessories**

Accessories must be ordered as separate items:

**Mounting plate**

For assembly of SQM33... and VKP... proportional controlling element  
See Mounting instruction 74 319 0843 0 (M7646)

**ASK33.1****Mounting kit**

For assembly of SQM33 and VKF41.xxC butterfly valve  
See Mounting instruction 74 319 0916 0 (M7813/7814)

**ASK33.4**

**Technical data**

Actuator	Operating voltage	AC / DC 24 V $\pm$ 20 % (load on interface)
	Power consumption	
	- SQM33.4...	Max. 7.5 W
	- SQM33.5... / SQM33.7...	Max. 10 W
	Perm. on time	50%, max. 3 minutes continuously
	Angular adjustment, usable range	Between 0° and max. 90°
	Mounting position	Optional
	Load on bearing	Refer to «Type summary»
	Degree of protection	
	- SQM33.41... / SQM33.51...	IP54 to EN 60 529-1
	- SQM33.550A9 / SQM33.750A9	IP40 (at the cable outlet, with no conduit connected) IP54 can be achieved with conduit connected
	 <b>Caution!</b>	
	<b>The bearing of the driven shaft must be protected against direct hazard of water and dust via corresponding mounting. If not, IP54 cannot be ensured over the full life cycle.</b>	
	Safety class	II to EN 60 730 part 1 and parts 2-14
	Direction of rotation	Can be selected on the basic unit
	Nominal output torque	Refer to «Type summary»
	Holding torque (when power applied)	Refer to «Type summary»
	Holding torque (when power not applied)	Refer to «Type summary»
	Reproducibility (typically when new)	$\pm$ 0.2° (when used with the basic units of the LMV27.100x2 / LMV37.400x2)
	Nominal resolution encoder supervision	0.7°
	Running times	Is determined by the basic unit
	Weight	Approx. 1.4 kg
	Direction of rotation (when facing the shaft)	
	- Standard	Counterclockwise
	- Reverse	Clockwise
	0-position of actuator drive shaft	Supply state 0 $\pm$ 0.6°
	Temperature of the mounting surface	Max. 60 °C
	Conduit connecting thread	
	- SQM33.550A9	NPSM ½"-14 Usable depth of thread: Min. 10 mm
	Life cycle	250,000 start cycles (CLOSE $\Rightarrow$ OPEN $\Rightarrow$ CLOSE) under load with the rated torque in the entire rotation angle range. 2,000,000 control cycles under load with 75% of rated torque in rotation angle range of 10°



## Technical data (cont'd)

## Cable connection

**SQM33.41... / SQM33.51... / SQM33.71...**

Connector

Duomodule RAST2.5  
6-poles  
Supplied by Lumberg  
Part no. 3521 06 K00**SQM33.55... / SQM33.75...**Free from halogen  
UL-listed

Color

Black

Number of conductors

6

Outside dia. of jacket

5.5...6.5 mm

- Cross-sectional area

AWG22 / 0.34 mm<sup>2</sup> / 7 wires

Insulation dia. single conductor

1.45...1.6 mm

Shore hardness of outer jacket

Defined by UL (88A)

- Temperature range
- Conductor resistance
- Insulation resistance
- Operating voltage  
conductor-conductor
- Test voltage  
conductor-conductor
- Test voltage  
conductor-outer jacket
- Degree of protection

-20...+70 °C

&lt;100 Ω / km

&gt;20 MΩ x km

&lt;50 V

50 Hz effective / 1 min

&gt;300 V

&gt;3.75 kV to DIN EN 60730, chapter 13

IP40 at cable exit without connected  
conduit

- Connector

With screw terminal RAST3.5  
6-poles  
Supplied by PTR  
Part no. AK 1550

as well as

Duomodul plug connector RAST2.5  
6-pole  
Supplier Lumberg  
Order number: 3521 06 K00Environmental  
conditions**Storage**

DIN EN 60 721-3-1

Climatic conditions

Class 1K3

Mechanical conditions

Class 1M2

Temperature range

-20...+70 °C

Humidity

&lt;95% r.h.

**Transport**

DIN EN 60 721-3-2

Climatic conditions

Class 2K3

Mechanical conditions

Class 2M2

Temperature range

-20...+70 °C

Humidity

&lt;95% r.h.

**Operation**

DIN EN 60 721-3-3

Climatic conditions

Class 3K5

Mechanical conditions

Class 3M4

Temperature range

-20...+60 °C

Humidity

&lt;95% r.h.

Installation altitude

Max. 2,000 m above sea level

**Caution!****Condensation, formation of ice and ingress of water are not permitted!****If this is not observed, there is a risk of loss of safety functions and a risk of electric shock.**



## Function

The SQM33... actuators are of robust design and have a gear train with only little backlash.

Control and position feedback take place via a common cable.

The same cable is used for powering the actuator.

The actuators are driven by stepper motors and can be positioned with a resolution of 0.1°.

The characteristics and settings (running time, direction of rotation, end positions) of the SQM33... are determined by the controlling basic unit (e.g. LMV27.100x2; for details, refer to the Basic Documentation of the LMV27.100x2 (P7541)).

The running times of the controlling elements are varied by the basic unit depending on the burner's control phase (e.g. startup phase: short running time; operation: long running time).



### Application note!

Single-sided load torque is recommended due to the type of gear train for the SQM33.6 / SQM33.7 actuators. In the event of load on both sides, a backlash of  $\pm 0.3^\circ$  must also be considered in addition to plant design or setting.



Dimensions

Dimensions in mm

SQM33.41... / SQM33.51... / SQM33.71...

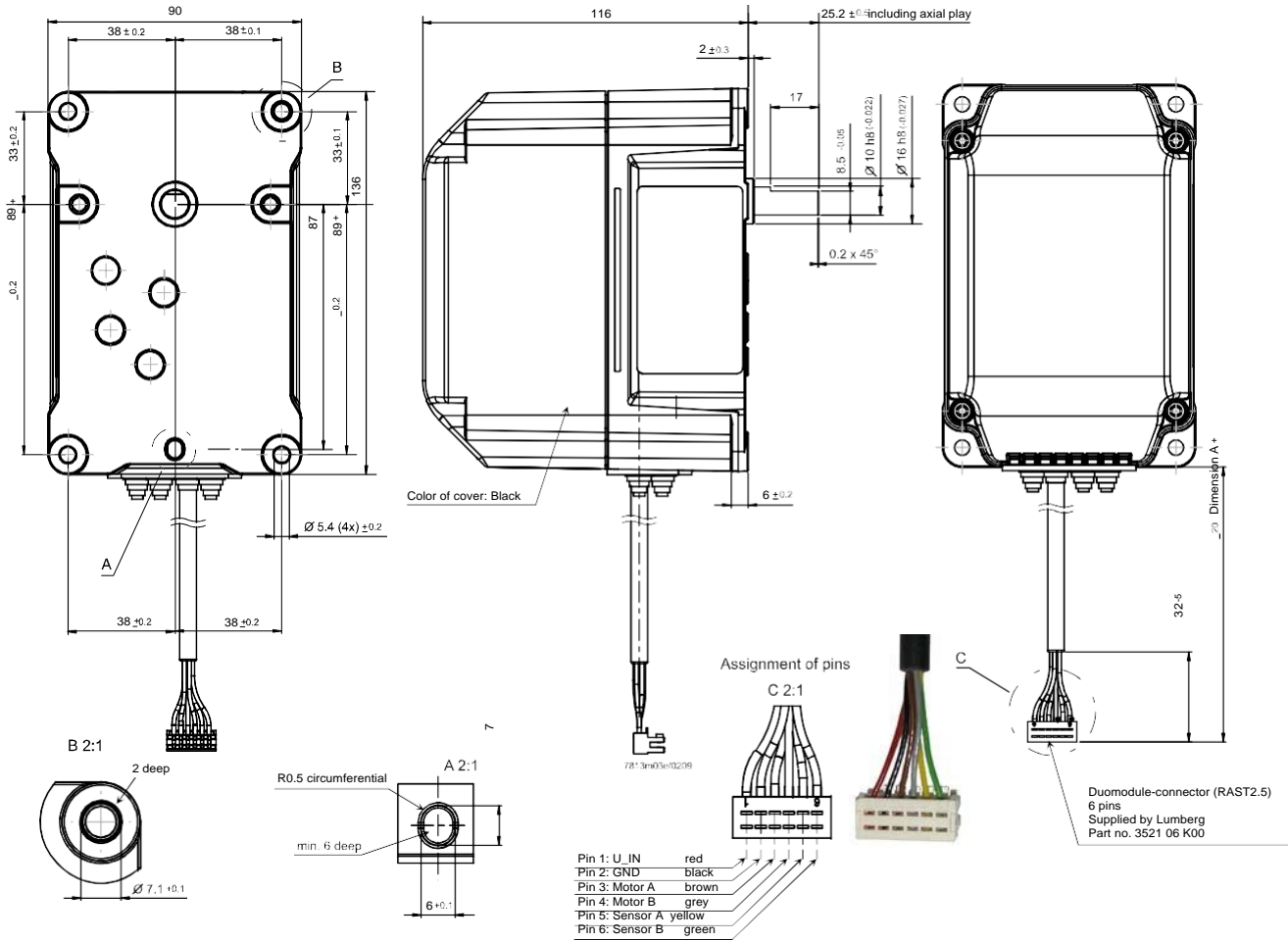

Product No.	Dimension A
SQM33.410A9	1500
SQM33.411A9	3000
SQM33.510A9	1500
SQM33.511A9	3000
SQM33.711A9	3000



Dimensions (cont'd)

Dimensions in mm

SQM33.550A9 / SQM33.750A9

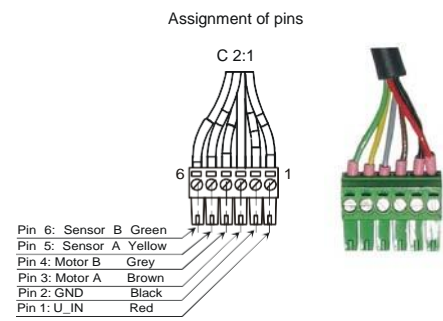
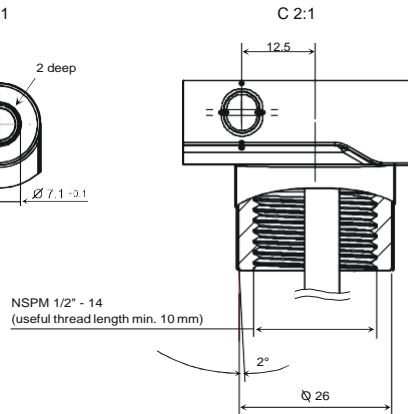
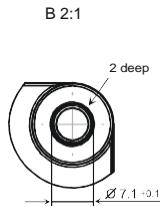
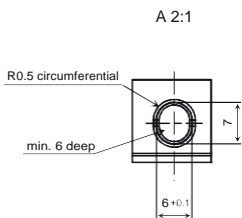
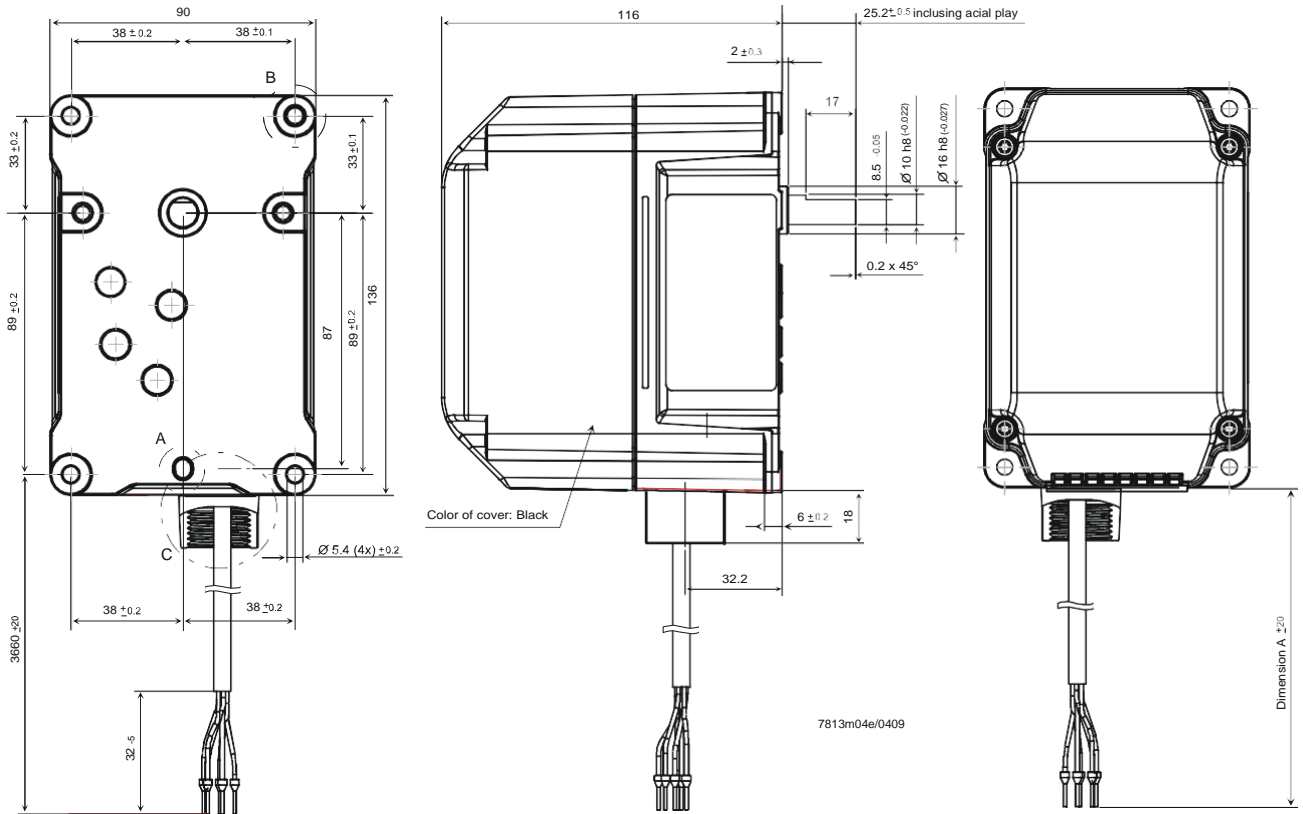

**Note!**  
The connector assignment with the RAST2.5 connector is the same as with the RAST3.5 connector.

Product No.	Dimension A
SQM33.550A9	3600
SQM33.750A9	3600