



บริษัท เอดีดี เฟอร์เนส จำกัด

ADD FURNACE CO.,LTD.

44 ซอยบรมราชชนนี 70 ถนนบรมราชชนนี แขวงศาลาธรรมสพน์ เขตทวีวัฒนา กรุงเทพฯ 10170

โทร: 02-888-3472 โทร: ออกแบบ:08-08-170-170 แฟกซ์: 02-888-3258

https://www.add-furnace.com E-mail: [sales@add-furnace.com](mailto:sales@add-furnace.com)

## General Specifications

GS 05P01D31-01EN

UT35A, UT32A  
Digital Indicating Controller  
(Panel Mounting Type)

UTAdvanced®

Functional Enhancement

### Overview

The UT35A and UT32A digital indicating controllers employ an easy-to-read, 14-segment large color LCD display, along with navigation keys, thus greatly increasing the monitoring and operating capabilities. A ladder sequence function is included as standard. The short depth of the controller helps save instrument panel space. The UT35A and UT32A also support open networks such as Ethernet communication.

The UT35A and UT32A have a DIN rail mounting type (with option code /MDL). For more details, please see General Specification GS 05P01D81-01EN.

### Features

- A 14-segment, active (PV display color changing function) color LCD display is employed. Two five-digit, high-resolution displays are possible. Alphabet letters can be displayed in an easy-to-read manner. The guide display shows parameter names.
- Easy to operate  
Navigation keys (SET/ENTER and Up/Down/Left/Right arrow keys) are employed to facilitate making settings.
- 65 mm depth  
The small depth enables the mounting in a thin and small instrumented panel.
- Ladder sequence function is included as standard. This function allows for creating a simple sequence control. Dedicated LL50A Parameter Setting Software (sold separately) allows for performing programming using a ladder language.
- Various built-in open network functions such as Ethernet are available.  
Easy connection with various vendors' PLCs is possible. (UT32A support CC-Link and RS485 communication only.)
- Quick setting function  
Setting only the minimum necessary parameters for operation is possible.
- Equipped with a multitude of functions  
Universal I/O and retransmission output are included as standard. PID control, heating/cooling control, etc. are available.
- LL50A Parameter Setting Software (sold separately)  
The parameters and ladder programs of UTAdvanced digital indicating controller can be built from a PC using this software. It makes data management even easier.
- Dust-proof and drip-proof  
IP66 (for front panel) (Not applicable to side-by-side close mounting.)  
NEMA4 (Hose-down test only)



### Functional Specifications

#### Control Specifications

##### (1) Control Mode

Single-loop control

##### (2) Control period

200 ms

Table of Number of Inputs and Outputs

Model and (See the model code)	Number of analog input points	Number of analog output points <sup>(1)</sup>	Number of contact input points	Number of contact output points <sup>(3)</sup>
UT35A				
-x0x	1	1	2	3
-x1x	1	1	4	5
-x2x	1	1 <sup>(2)</sup>	7	8
UT32A				
-x0x	1	1	2	3
-x1x	1	1	2	3
-x2x	1	1 <sup>(2)</sup>	4	5

\*1: Excluding control output

\*2: In the case cooling control output is analog output, it cannot be used for transmission output.

\*3: Excluding control output relays



## ■ Control Computation Function

### (1) Types of control

- PID control
  - ON/OFF control (\*4)
  - Two-position two-level control (\*5)
  - Heating and cooling control (\*5)
- \*4: Not selectable for Position proportional type  
\*5: Selectable for heating and cooling control

### (2) Control Computation Function

- (a) Target setting point and the number of PID parameter groups  
Respectively, four sets of target setpoints, alarm setpoints, and PID parameters can be set.
- (b) Selecting the PID parameter group  
The following PID parameter groups can be selected.
- Target setpoint number (SPNO) (The PID number can be set arbitrarily.)
  - Measured input zone PID
  - Target setpoint zone PID
  - Reached target setpoint zone PID
- (c) Auto-tuning
- Tuning results can be selected from two options, Normal or Stable.
  - Tuning output limit can be set. (It cannot be used in heating/cooling control.)
- (d) "Super" function: Overshoot-suppressing function  
(e) "Super 2" function: Hunting-suppressing function  
(f) STOP preset output function  
(g) Input ERROR preset output function  
(h) MANUAL preset output function

### (3) Operation Mode Switching

<b>Operation mode switching</b>	AUTO/MANUAL and RUN/STOP switching REMOTE/LOCAL switching (only model with communication option)
---------------------------------	---

### (4) Control Parameter Setting Range

<b>Proportional band</b>	0.1 to 999.9%
<b>Integral time</b>	1 to 6000 sec. or OFF (using manual reset)
<b>Derivative time</b>	1 to 6000 sec. or OFF
<b>ON/OFF control hysteresis (one or two hysteresis points)</b>	0.0 to 100.0% of measured input range width
<b>Preset output value</b>	-5.0 to 105.0% (however, 0 mA or less cannot be output)
<b>High/low output limiter</b>	-5.0 to 105.0% Low limit setpoint < high limit setpoint
<b>Tight shut function</b>	When manual control is carried out with 4 to 20 mA output, control output can be reduced to about 0 mA.
<b>Rate-of-change limiter of output</b>	0.1 to 100.0%/sec., OFF
<b>Output deadband</b>	For heating and cooling control: -100.0 to 50.0% For position proportional control: 1.0 to 10.0%

## Alarm Functions

### • Types of Alarm

<b>Measured value alarm</b>	PV (measured value) high/low limit alarm Deviation high/low limit alarm Deviation high and low limits alarm
<b>Deviation alarm</b>	Deviation within high and low limits alarm
<b>Rate-of-change alarm</b>	Analog input PV high/low limit alarm Feedback input high/low limit alarm PV rate-of-change alarm
<b>Setpoint alarm</b>	SP (setpoint) high/low limit alarm Target SP high/low limit alarm Target SP deviation high/low limit alarm Target SP deviation high and low limits alarm Target SP deviation within high and low limits alarm
<b>Output alarm</b>	Control output high/low limit alarm Cooling control output high/low limit alarm
<b>Other alarms</b>	Heater disconnection alarm (for /HA option) Self-diagnosis alarm FAIL

### • Alarm Functions

<b>Alarm output action</b>	Alarm stand-by action Alarm latch (forced reset) function Alarm hysteresis Alarm ON/OFF delay timer
<b>Number of alarm settings</b>	4
<b>Number of alarm output points</b>	Up to 8 (differs by model code)

## Contact I/O Function

This function allows for allocating the input error condition, operation condition, alarm condition or other conditions to the contact input and contact output.

<b>Contact input</b>	AUTO/MANUAL switching
	REMOTE/LOCAL switching (only model with communication option)
	STOP/START switching
	Switching to AUTO
	Switching to MANUAL
	Switching to REMOTE (only model with communication option)
	Switching to LOCAL (only model with communication option)
	AUTO-TUNING START/STOP switching
	LCD backlight ON/OFF switching
	Message interrupt displays 1 through 4 SP number specification PID number specification Manual preset output number specification
<b>Contact output</b>	Alarms 1 through 4 Status output

## Ladder Sequence Function

### (1) Number of I/O Points

	UT35A	UT32A
<b>Number of digital input points</b>	Up to 7	Up to 4
<b>Number of digital output points</b>	Up to 8	Up to 5

This is limited by the number of contact I/O signal points. (See the model code.)

### (2) Types of Command

	Number of commands	Remark
<b>Number of basic command types</b>	13	Load, AND, OR, Timer, Counter, etc.
<b>Number of application command types</b>	73	Comparison, reverse, addition/subtraction/multiplication/division, logic operation, high/low limiter, etc.



**(3) Sequence Device**

	Types of device	Number of points
Digital I/O	Input relay	7 (max)
	Output relay	8 (max)
Internal device	M relay (bit data)	256
	DAT register (data)	28
	P register (parameter)	10
	K register (constant)	30
Special device	Special relay (bit data)	12

Process data and process relay can be used besides the above-mentioned.

**Communication Function**

	Function	Method	Interface	Targets	Max connection	Communication Data
Modbus/TCP	A standard industry protocol allowing communications between the controller and devices such as PCs, PLCs, and DCSS.	Server	Ethernet	PLC and others	2 connections	PV, SP, OUT, ALM etc
		Gateway	Ethernet +RS-485	RS-485: UT75A, UT55A, UT52A, UT35A, UT32A, UP55A, UP35A, UM33A <sup>(1)</sup>	31 units	
Slave		RS-485	PLC and others, UT75A, UT55A, UT52A, UT35A, UT32A, UP55A, UP35A, UM33A <sup>(2)</sup>	31 units		
PROFIBUS-DP	Used for communication between PLCs and remote I/O, enabling high-speed data transmission.	Slave	RS-485	PLC and others	Number of nodes: 126	
		Modbus master function	RS-485	UT75A, UT55A, UT52A, UT35A, UT32A, UP55A, UP35A	31 Units (Main Controller is included.)	
CC-Link		Slave	RS-485	PLC and others	Number of nodes: 42 (Remote device)	
		Modbus master function	RS-485	UT75A, UT55A, UT52A, UT35A, UT32A, UP55A, UP35A, UM33A	31 Units (Main Controller is included.)	
DeviceNet		Slave	RS-485	PLC and others	Number of nodes: 64	
		Modbus master function	RS-485	UT75A, UT55A, UT52A, UT35A, UT32A, UP55A, UP35A	31 Units (Main Controller is included.)	
Peer to peer	A protocol allowing multiple controllers to send and receive data between one another. The Ladder Program is used.	Multi-drop	RS-485 (2 wire only)	UT75A, UT55A, UT52A, UT35A, UT32A, UP55A, UP35A, UP32A	Read/Write: 4 units Read only : 28 units	
Coordinated Communication	A protocol to coordinate the operation of two or more instruments controlling the same process.	Master/Slave	RS-485	UT75A, UT55A, UT52A, UT35A, UT32A, UP55A, UP35A, UP32A, UM33A <sup>(2)</sup>	Master : 1 unit Slave : 31 units	
PC link	The proprietary Yokogawa protocol allowing communications to PCs, PLCs and touch panels.	Slave	RS-485	PC and others, UT75A, UT55A, UT52A, UT35A, UT32A, UP55A, UP35A, UP32A, UM33A <sup>(2)</sup>	31units	
Ladder	A protocol to communicate to PLCs.					

\*1: UT digital indicating controller, Signal conditioner JUXTA, Power monitor POWERCERT can be connected.

\*2: UT digital indication controllers can be connected.

**(4) Program capacity**

Max Program capacity: 300 steps \*

\*: Available number of steps differs according to the parameters and using command.

**(5) Ladder computation period**

Ladder computation period is the same as control period.





## Hardware Specifications

### Display Specifications

- PV display  
5-digit, 14-segment active color LCD (white/red)  
Character height: 21.5 mm for UT35A and 13.0 mm for UT32A
- Data display  
5-digit, 11-segment color LCD (orange)
- Bar graph display  
12-segment color LCD (orange)

### Universal Input Specifications

- Number of input points: 1
- Types of input, instrument range, and measurement accuracy (see the table below)

Types of input	Instrument range		Accuracy	
	°C	°F		
Thermocouple	K	-270.0 to 1370.0°C	-450.0 to 2500.0°F	±0.1% of instrument range ±1 digit for 0°C or more
		-270.0 to 1000.0°C	-450.0 to 2300.0°F	
		-200.0 to 500.0°C	-200.0 to 1000.0°F	
	J	-200.0 to 1200.0°C	-300.0 to 2300.0°F	±0.2% of instrument range ±1 digit for less than 0°C
		-270.0 to 400.0°C	-450.0 to 750.0°F	
	T	0.0 to 400.0°C	-200.0 to 750.0°F	However, ±2% of instrument range ±1 digit for less than -200°C of thermocouple K ±1% of instrument range ±1 digit for less than -200°C of thermocouple T
	B	0.0 to 1800.0°C	32 to 3300°F	±0.15% of instrument range ±1 digit for 400°C or more ±5% of instrument range ±1 digit for less than 400°C
	S	0.0 to 1700.0°C	32 to 3100°F	±0.15% of instrument range ±1 digit
	R	0.0 to 1700.0°C	32 to 3100°F	
	N	-200.0 to 1300.0°C	-300.0 to 2400.0°F	±0.1% of instrument range ±1 digit ±0.25% of instrument range ±1 digit for less than 0°C
	E	-270.0 to 1000.0°C	-450.0 to 1800.0°F	±0.1% of instrument range ±1 digit for 0°C or more
	L	-200.0 to 900.0°C	-300.0 to 1600.0°F	
	U	-200.0 to 400.0°C	-300.0 to 750.0°F	
		0.0 to 400.0°C	-200.0 to 1000.0°F	±0.2% of instrument range ±1 digit for less than 0°C However, ±1.5% of instrument range ±1 digit for less than -200.0°C of thermocouple E
	W (*)	0.0 to 2300.0°C	32 to 4200°F	±0.2% of instrument range ±1 digit
Platinum 2	0.0 to 1390.0°C	32.0 to 2500.0°F	±0.1% of instrument range ±1 digit	
PR20-40	0.0 to 1900.0°C	32 to 3400°F	±0.5% of instrument range ±1 digit for 800°C or more Accuracy not guaranteed for less than 800°C	
W97 Re3-W75 Re25	0.0 to 2000.0°C	32 to 3600°F	±0.2% of instrument range ±1 digit	
Resistance-temperature detector (RTD) 3-wire	JPt100	-200.0 to 500.0°C	-300.0 to 1000.0°F	±0.1% of instrument range ±1 digit (*)
		-150.00 to 150.00°C	-200.0 to 300.0°F	
	Pt100	-200.0 to 850.0°C	-300.0 to 1560.0°F	±0.1% of instrument range ±1 digit (*)
		-200.0 to 500.0°C	-300.0 to 1000.0°F	
		-150.00 to 150.00°C	-200.0 to 300.0°F	
Standard signal	0.400 to 2.0000 V	-	±0.1% of instrument range ±1 digit	
	1.000 to 5.000 V	-		
	4.00 to 20.00 mA	-		
DC voltage	0.000 to 2.000 V	-	±0.1% of instrument range ±1 digit	
	0.00 to 10.00 V	-		
DC current	-10.00 to 20.00 mV	-	±0.1% of instrument range ±1 digit	
	0.00 to 20.00 mA	-		

The accuracy is that in the standard operating conditions: 23 ±2°C, 55 ±10%RH, and power frequency at 50/60 Hz.

\*1: ±0.3°C and ±1 digit in the range between 0 and 100°C  
±0.5°C ±1 digit in the range between -100 and 200°C

\*2: W-5% Re/W-26% Re (Hoskins Mfg.Co.), ASTM E988

- Applicable standards: JIS, IEC and DIN (ITS-90) for thermocouples and resistance-temperature detectors (RTD)
- Input sampling period: Synchronized to control period
- Burnout detection

Upscale and downscale of function, and OFF can be specified for the standard signal of thermocouple and resistance-temperature detector (RTD).  
For integrated signal input, 0.1 V or 0.4 mA or less is judged as a burnout.

- Input bias current: 0.05 µA (for thermocouple and resistance-temperature detector (RTD))
- Resistance-temperature detector (RTD) measured current: About 0.16 mA
- Input resistance  
1 MΩ or more for thermocouple/mV input  
About 1 MΩ for voltage input  
About 250 Ω for current input (with built-in shunt resistance)
- Allowable signal source resistance  
250 Ω or less for thermocouple/mV input  
Effect of signal source resistance: 0.1 µV/Ω or less  
2 kΩ or less for DC voltage input  
Effect of signal source resistance: about 0.01%/100 Ω
- Allowable wiring resistance  
Up to 150 Ω per line for resistance-temperature detector (RTD) input (conductor resistance between the three lines shall be equal)  
Effect of wiring resistance: ±0.1°C/10 Ω
- Allowable input voltage/current  
±10 V DC for thermocouple/mV/mA or resistance-temperature detector (RTD) input  
±20 V DC for V input  
±40 mA DC for mA input
- Noise reduction ratio  
40 dB or more (at 50/60 Hz) in normal mode  
120 dB or more (at 50/60 Hz) in common mode
- Reference junction compensation error  
±1.0°C (15 to 35°C)  
±1.5°C (-10 to 5°C and 35 to 50°C)

### Contact Input Specifications

- Number of points: 2 points (standard)  
For the maximum number of points, see the model and suffix code table.
- Input type: no-voltage contact input or transistor contact input
- Input contact capacity: 12 V DC, 10 mA or more  
Be sure to use a contact with a minimum ON current of 1 mA or less
- ON/OFF detection  
For no-voltage contact input:  
Contact resistance 1 kΩ or less in ON state  
Contact resistance 50 kΩ or more in OFF state  
Transistor contact input:  
2 V or less in ON state  
Leak current 100 µA or less in OFF state
- Status detection minimum hold time: control period + 50 ms
- Application: SP switching, operation mode switching, event input



### Analog Output Specifications

- Number of points  
Control output (heating-side output): 1 point (standard), which is shared with transmission output  
Cooling-side output: 1 point, which is shared with transmission output
- Output functions  
Current output or voltage pulse output
- Current output  
4 to 20 mA DC or 0 to 20 mA DC/load resistance 600 Ω or less
- Current output accuracy  
±0.1% of span (however, ±5% of span for 1 mA or less)  
The accuracy is that in the standard operating conditions: 23 ±2°C, 55 ±10%RH, and power frequency at 50/60 Hz
- Voltage pulse output  
Application: time proportional output ON voltage: 12V or more/load resistance of 600 Ω or more  
OFF voltage: 0.1 V DC or less  
Time resolution: 10 ms or 0.1% of output value, whichever is larger

### Retransmission Output Specifications

- Number of points: 1 point (standard), which is shared with 15 V DC loop power supply  
Additional 1 points when analog control output are not used
- Output function: current output  
4 to 20 mA DC or 0 to 20 mA DC/load resistance 600 Ω or less
- Current output accuracy (conversion accuracy from PV display on the set scale): ±0.1% of span (however, ±5% of span for 1 mA or less)  
The accuracy is that in the basic operating conditions: 23 ±2°C, 55 ±10%RH, and power frequency at 50/60 Hz  
This is not conversion accuracy through input and output but the performance of transmission output itself.

### 15V DC Loop Power Supply Specifications

- Number of points: 1 point (standard), which is shared with retransmission output  
Control output (1 point) can also be used.
- Supply voltage: 14.5 to 18.0 V DC
- Maximum supply current: about 21 mA (with short-circuit current limiting circuit)

### Step Response Time Specifications

Within 1 s

(Response time at 63% of transmission output when a change is made stepwise in the range between 10 and 90% of input span)

### Relay Contact Output Specifications

- Types of contact and number of points  
Control relay output: one 1c-contact point  
Control output of heating and cooling control: 2 1a-contact points  
Alarm output: 3 1a-contact points (Common is separated)

- Contact rating  
1c-contact: 3 A at 250 V AC or 3 A at 30 V DC (resistance load)  
1a-contact:  
For alarm output: 1 A at 240 V AC or 1 A at 30 V DC (resistance load)  
For output of heating and cooling control relay output: 3 A at 240 V AC or 3 A at 30 V DC (resistance load)  
\*: The control output should always be used with a load of 10 mA or more. of  
The alarm output should always be used with a load 1 mA or more.
- Application: time proportional output, alarm output, FAIL output, etc.
- Time resolution for control output: 10 ms or 0.1% of output value, whichever is larger

### Transistor Contact Output Specifications

- Number of points: see the model and suffix code table
- Output form: open collector (sink current)
- Output contact capacity: Up to 24 V DC, 50 mA
- Output time resolution: min 200 ms
- Application: alarm output, FAIL output, etc.

### Position Proportional Output Specifications

- Position signal input  
Slide resistance: 100 Ω to 2.5 kΩ of total resistance  
100% side and slide line: with disconnection detection  
0% side: without disconnection detection  
Current input: 4 to 20 mA DC (with disconnection detection)  
Input resistance: about 330 Ω
- Sampling period: 50 ms
- Measurement resolution: 0.1% of input span
- Position proportional relay output  
UT35A: Two 1a-contact points, 3 A at 250 V AC or 3A at 30 V DC (resistance load)  
UT32A: Two 1a-contact points, 3 A at 240 V AC or 3A at 30 V DC (resistance load)  
\*: This should always be used with a load of 10 mA or more.

### Heater Break Alarm Specifications (for /HA Option)

- Function: Measures the heater current using an external current transformer (CT) and generates a heater break alarm when the measured value is less than the disconnection detection value.
- Number of input points: 2 points
- Number of output points: 2 points (transistor contract output)
- CT input resistance: about 9.4 Ω
- CT input range: 0.0 to 0.1 Arms (0.12 Arms or more cannot be applied)
- Heater current alarm setting range: OFF, 0.1 to 300.0 Arms  
Heater current measured value display range: 0.0 to 360.0 Arms  
\*: The CT ratio can be set. CT ratio setting range: 1 to 3300
- Recommended CT: CT from URD Co. Ltd.  
CTL-6-S-H: CT ratio 800, measurable current range: 0.1 to 80.0 Arms  
CTL-12L-30: CT ratio 3000, measurable current range: 0.1 to 180.0 Arms
- Heater current measurement period: 200 ms
- Heater current measurement accuracy: ±5% of CT input range span ±1 digit (CT error is not included)
- Heater current detection resolution: Within 1/250 of CT input range span
- Disconnection detection ON time: Minimum 200ms. (for time proportional output)



### 24 V DC Loop Power Supply Specifications (for /LP Option)

- Application: Power is supplied to the 2-wire transmitter.
- Supply voltage: 21.6 to 28.0 V DC
- Rated current: 4 to 20 mA DC
- Maximum supply current: About 30 mA (with short-circuit current limiting circuit)

### Safety and EMC Standards

- Safety: Compliant with IEC/EN 61010-1 (CE), IEC/EN 61010-2-201 (CE), IEC/EN 61010-2-030 (CE), approved by CAN/CSA C22.2 No. 61010-1 (CSA), approved by UL 61010-1.

Installation category: II

Pollution degree: 2

Measurement category: I (CAT I) (UL, CSA)  
O (Other) (CE)

Rated measurement input voltage: Max. 10 V DC

Rated transient overvoltage: 1500 V (\*)

\*: This is a reference safety standard value for measurement category I of CSA/UL 61010-1, and for measurement category O of IEC/EN 61010-2-030. This value is not necessarily a guarantee of instrument performance.

- EMC standards: Compliant with CE marking EN 61326-1 Class A, Table 2 (For use in industrial locations), EN 61326-2-3 \*: The instrument continues to operate at a measurement accuracy of within ±20% of the range during testing. EN 55011 Class A, Group 1 EN 61000-3-2 Class A EN 61000-3-3 EMC Regulatory Arrangement in Australia and New Zealand EN 55011 Class A, Group 1
- KC marking: Electromagnetic wave interference prevention standard, electromagnetic wave protection standard compliance

### Power Supply Specifications and Isolation

- Power supply Rated voltage: 100 to 240 V AC (+10%/-15%), 50/60 Hz 24 V AC/DC (+10%/-15%) (When the /DC option is specified)
- Power consumption: UT35A: 18 VA (For the /DC option. DC: 9 VA, AC: 14 VA) UT32A: 15 VA (For the /DC option. DC: 7 VA, AC: 11 VA)
- Storage: Nonvolatile memory
- Allowable power interruption time: 20 ms (at 100 V AC)
- Withstanding voltage 2300 V AC for 1 minute between primary and secondary terminals (UL, CSA) 3000 V AC for 1 minute between primary and secondary terminals (CE) 1500 V AC for 1 minute between primary terminals 500 V AC for 1 minute between secondary terminals (Primary terminals = Power (\*) and relay output terminals, Secondary terminals = Analog I/O signal terminals, contact input terminals, communication terminals, and functional grounding terminals.) \*: Power terminals for 24 V AC/DC models are the secondary terminals.
- Insulation resistance Between power supply terminals and a grounding terminal: 20 MΩ or more at 500 V DC

### Isolation specifications

PV (universal) input terminal	Internal circuits	Power supply
Control and transmission (analog) output terminal (not isolated between the analog output terminals) Valve position (feedback) input terminal		
Control relay (c-contact or 2 a-contact) output terminal		
Alarm-1 relay (a-contact) output terminal		
Alarm-2 relay (a-contact) output terminal		
Alarm-3 relay (a-contact) output terminal		
Position proportional relay output terminal		
Contact input terminal (All) RS485 communication terminal (2 ports)		
24 V DC loop power supply terminal		
Contact output (transistor) terminal		
Ethernet/PROFIBUS-DP/CC-Link/DeviceNet communication terminal		
Current transformer input terminal		

The circuits divided by lines are insulated mutually.

### Environmental Conditions

#### Normal operating conditions

- Ambient temperature: -10 to 50°C (side-by-side mounting: -10 to 40 °C)  
If the CC-Link option is specified, 0 to 50 °C for UT35A; 0 to 40 °C for UT32A. (side-by-side mounting: 0 to 40 °C for UT35A and UT32A with CC-Link option)
- Ambient humidity: 20 to 90% RH (no condensation)
- Magnetic field: 400 A/m or less
- Continuous vibration (at 5 to 9 Hz) Half amplitude of 1.5 mm or less (at 9 to 150 Hz) 4.9 m/s<sup>2</sup> or less, 1 oct/min for 90 minutes each in the three axis directions
- Rapid vibration: 14.7 m/s<sup>2</sup>, 15 s or less
- Impact: 98 m/s<sup>2</sup> or less, 11 msec.
- Installation altitude: 2,000 m or less above sea level
- Warm-up time: 30 minutes or more after the power is turned on
- Start-up time within 10 s

#### Transportation and Storage Conditions

- Temperature: -25 to 70°C
- Temperature change rate: 20°C per hour or less
- Humidity: 5 to 95%RH (no condensation)

#### Effects of Operating Conditions

- Effect of ambient temperature  
For voltage or TC input: ±1 μV/°C or ±0.01% of F.S. (instrument range)/°C, whichever is greater  
For RTD input: ±0.05°C/°C (ambient temperature) or less  
For current input: ±0.01% of F.S. (instrument range)/°C  
For analog output: ±0.02% of F.S./°C or less
- Effect of power supply fluctuation:  
For analog input: ±0.05% of F.S. (instrument range) or less  
For analog output: ±0.05% of F.S. or less (Each within rated voltage range)



■ Block Diagram

Single Loop Control

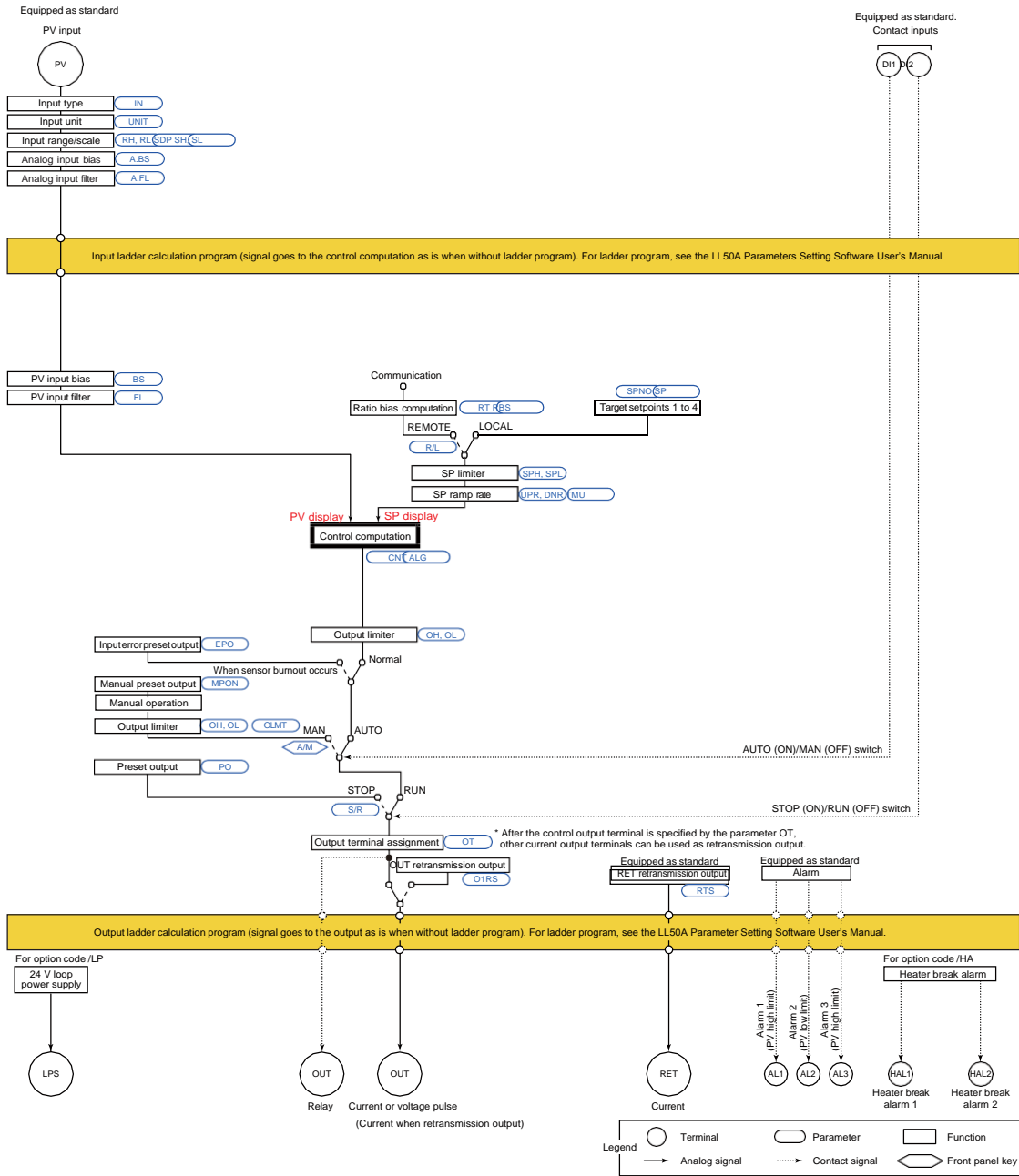





### Terminal Arrangement

#### Terminal Arrangement for UT35A Single Loop Control

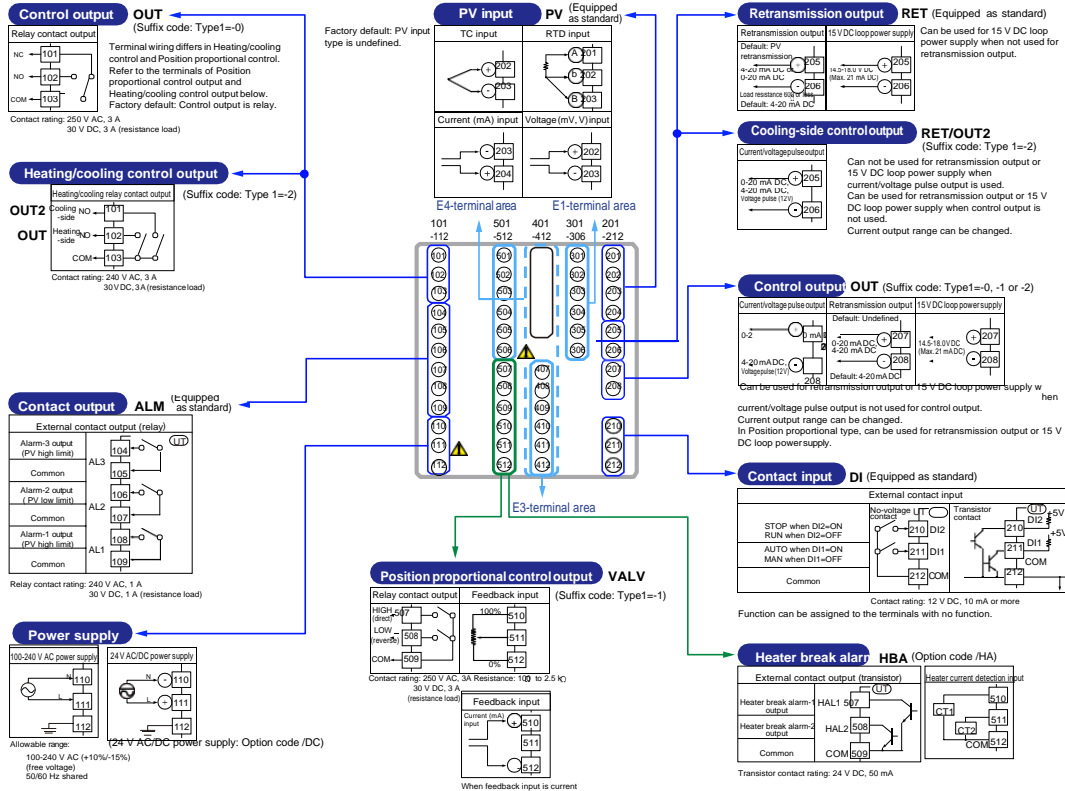



บริษัท เอดีดี เฟอร์เนซ จำกัด

**ADD FURNACE CO.,LTD.**

44 ซอยบรมราชชนนี 70 ถนนบรมราชชนนี แขวงศาลาธรรมสพน์ เขตทวีวัฒนา กรุงเทพฯ 10170

โทร: 02-888-3472 โทร: ออกรเบบ:08-08-170-170 แฟกซ์: 02-888-3258

https://www.add-furnace.com E-mail: [sales@add-furnace.com](mailto:sales@add-furnace.com)

E4-terminal area E1-terminal area

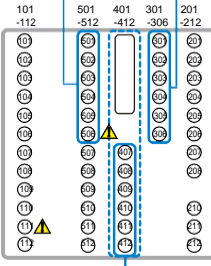

E3-terminal area

301-306 E1-Terminal Area

**Contact input DI** (Suffix code: Type 2=2)

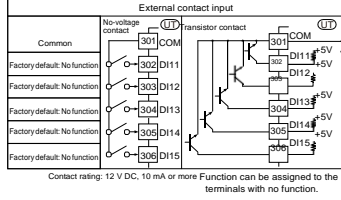

**Contact input / Contact output DI/DO** (Suffix code: Type 2=1)

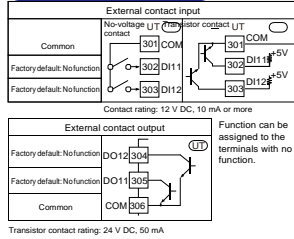

501-506 E4-Terminal Area

**Contact output DO** (Suffix code: Type 2=2)

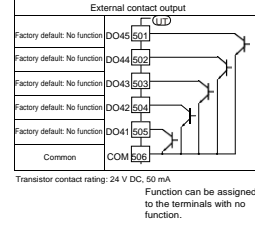

**24 V DC loop power supply**

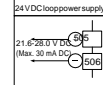

401-412 E3-Terminal Area

**RS-485 communication RS485**

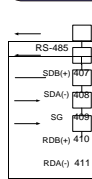

**Ethernet communication (with gateway function) ETHR**

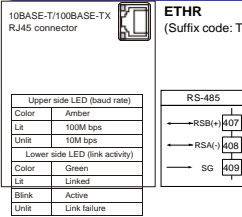

**PROFIBUS-DP communication (with Modbus master) PROF**

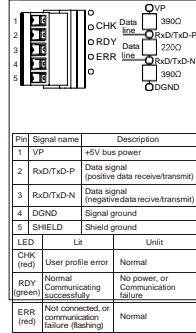

**CC-Link communication (with Modbus master) CC-L**

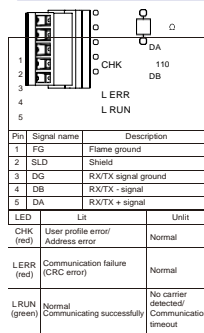

**DeviceNet communication (with Modbus master) DNET**

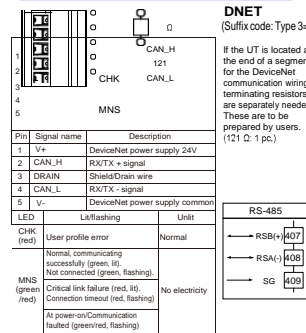



บริษัท เอดีดี เฟอร์เนส จำกัด

ADD FURNACE CO.,LTD.

44 ซอยบรมราชชนนี 70 ถนนบรมราชชนนี แขวงศาลาธรรมสพน์ เขตทวีวัฒนา กรุงเทพฯ 10170

โทร: 02-888-3472 โทร: ออกรับ: 08-08-170-170 แฟกซ์: 02-888-3258

https://www.add-furnace.com E-mail: sales@add-furnace.com

Terminal Arrangement for UT32A Single Loop Control

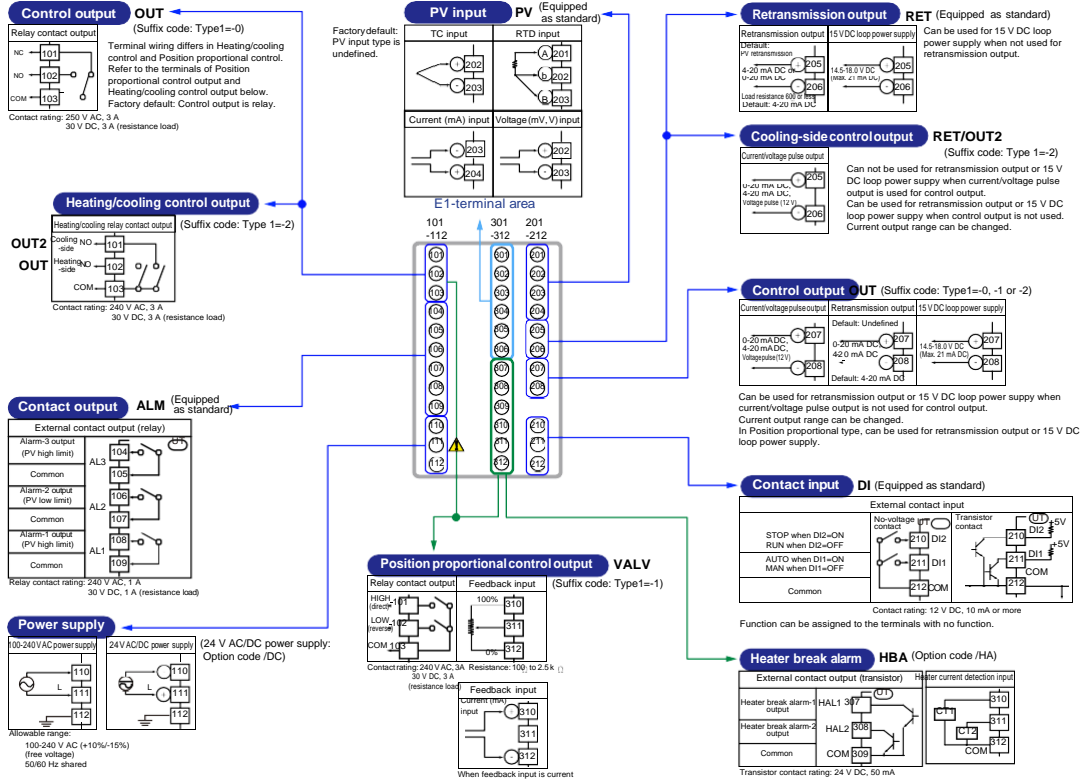

301-306 E1-Terminal Area

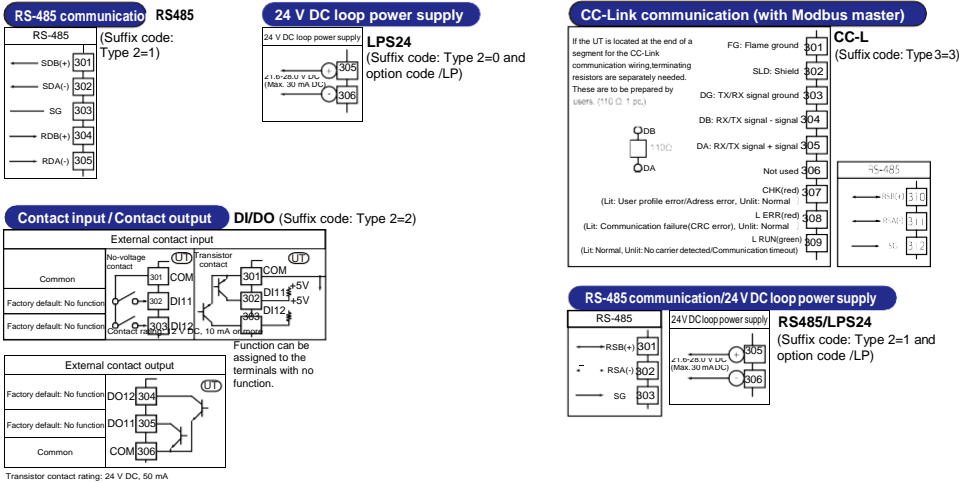



### External Dimensions and Panel Cutout Dimensions

#### UT35A

Unit: mm

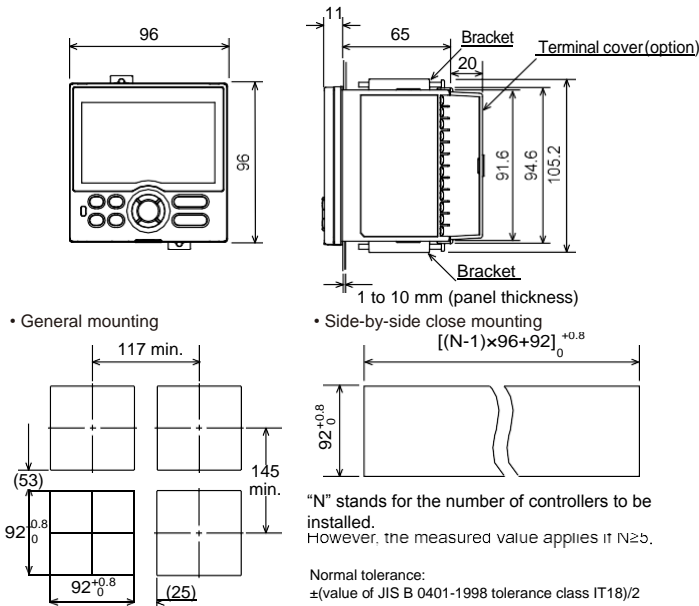

#### UT32A

Unit: mm

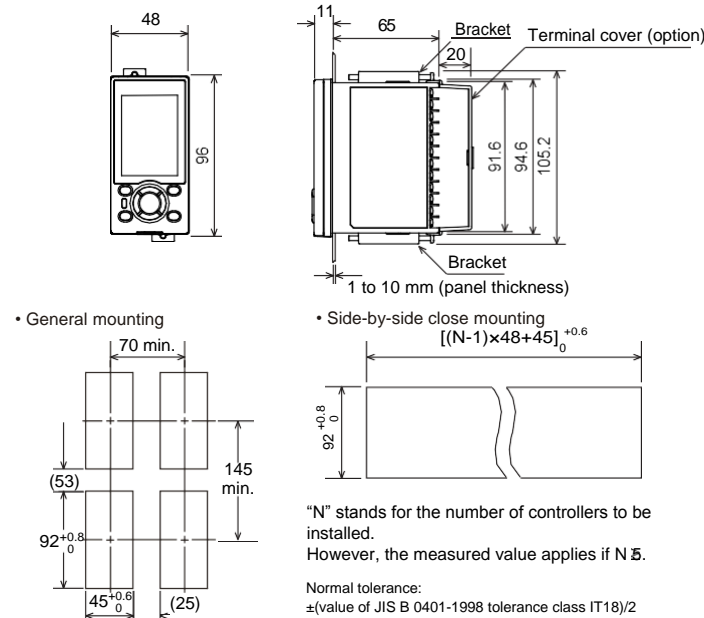

### Construction, Mounting, and Wiring

- Dust-proof and drip-proof: IP66 (Front panel) (Not applicable to side-by-side close mounting)/NEMA4 \*  
\*: Hose-down test only
- Material: Polycarbonate resin (Flame retardancy: UL94 V-0)
- Case color: White (Light gray) or Black (Light Charcoal gray)
- Weight: 0.5 kg or less
- External dimensions (mm):  
UT35A: 96 (width) x 96 (height) x 65 (depth from the panel surface)

UT32A: 48 (width) x 96 (height) x 65 (depth from the panel surface)

- Mounting: Direct panel mounting; mounting bracket, one each for upper and lower mounting
- Panel cutout dimensions (mm):  
UT35A: 92<sup>+0.8/0</sup> (width) x 92<sup>+0.8/0</sup> (height)  
UT32A: 45<sup>+0.6/0</sup> (width) x 92<sup>+0.8/0</sup> (height)
- Mounting position: Up to 30 degrees above the horizontal. No downward tilting allowed.
- Wiring: M3 screw terminal with square washer (signal wiring and power)



บริษัท เอดีดี เฟอร์เนส จำกัด

**ADD FURNACE CO.,LTD.**

44 ซอยบรมราชชนนี 70 ถนนบรมราชชนนี แขวงศาลาธรรมสพน์ เขตทวีวัฒนา กรุงเทพฯ 10170

โทร: 02-888-3472 โทร: ออกรับ: 08-08-170-170 แฟกซ์: 02-888-3258

https://www.add-furnace.com E-mail: [sales@add-furnace.com](mailto:sales@add-furnace.com)

■ Model and Suffix Code

Model	Suffix code	Option code	Description
<b>UT35A</b>			Digital Indicating Controller (Power supply: 100-240 V AC) (provided with retransmission output or 15 V DC loop power supply, 2 DIs, and 3 DOs)
Type 1: Basic control	-0		Standard type
	-1		Position proportional type
	-2		Heating/cooling type
Type 2: Functions	0		None
	1		2 additional DIs, 2 additional DOs
	2		5 additional DIs, 5 additional DOs
Type 3: Open networks	0		None
	1		RS-485 communication (Max.38.4 kbps, 2-wire/4-wire)
	2		<del>Ethernet communication (with serial gateway function)</del>
	3		PROFIBUS-DP communication (with Modbus master function)
	4		DeviceNet communication (with Modbus master function)
Display language <sup>(*)1</sup>	-1		English (Default. Can be switched to other language by the setting.)
	-2		German (Default. Can be switched to other language by the setting.)
	-3		French (Default. Can be switched to other language by the setting.)
	-4		Spanish (Default. Can be switched to other language by the setting.)
Case color	0		White (Light gray)
	1		Black (Light charcoal gray)
Fixed code		-00	Always "-00" (for Standard Code Model)
Option codes		/LP	24 V DC loop power supply <sup>(*)2</sup>
		/HA	Heater break alarm <sup>(*)3</sup>
		/DC	Power supply 24 V AC/DC
		/CT	Coating <sup>(*)4</sup>
		/CV	Terminal cover
		/MDL	Mount on DIN rail (without the display parts and keys) (please see the General Specifications GS 05P01D81-01EN.)
		/RSP	Non-isolated remote input (please see the General Specifications GS 05P01D31-81EN.)

- \*1: English, German, French, and Spanish are available for the guide display.
- \*2: The /LP option can be specified in the combination of Type 2 code (any of "0" or "1") and Type 3 code (any of "0" or "1".)
- \*3: The /HA option can be specified only when the Type 1 code is "-0" or "-2."
- \*4: When the /CT option is specified, the UT35A does not conform to the safety standards (UL and CSA) and CE marking (Products with /CT option are not intended for EEA-market).

Model	Suffix code	Option code	Description
<b>UT32A</b>			Digital Indicating Controller (Power supply: 100-240 V AC) (provided with retransmission output or 15 V DC loop power supply, 2 DIs, and 3 DOs)
Type 1: Basic control	-0		Standard type
	-1		Position proportional type
	-2		Heating/cooling type
	-D		Dual-loop type (please see the General Specifications GS 05P08D31-01EN.)
	-V		UT32A Digital Indicating Controller (Entry model) (please see the General Specification GS 05P01F31-01EN.)
	-C		
Type 2: Functions	0		None
	1		RS-485 communication (Max. 38.4 kbps, 2-wire/4-wire) <sup>(*)1</sup>
Type 3: Open networks	0		None
	3		Ethernet communication (with Modbus master function)
Display language <sup>(*)3</sup>	-1		English (Default. Can be switched to other language by the setting.)
	-2		German (Default. Can be switched to other language by the setting.)
	-3		French (Default. Can be switched to other language by the setting.)
	-4		Spanish (Default. Can be switched to other language by the setting.)
Case color	0		White (Light gray)
	1		Black (Light charcoal gray)
Fixed code		-00	Always "-00" (for Standard Code Model)
Option codes		/LP	24 V DC loop power supply <sup>(*)4</sup>
		/HA	Heater break alarm <sup>(*)5</sup>
		/DC	Power supply 24 V AC/DC
		/CT	Coating <sup>(*)6</sup>
		/CV	Terminal cover
		/MDL	Mount on DIN rail (without the display parts and keys) (In case of the Standard type, the Position proportional type, or the Heating/cooling type, please see the General Specifications GS 05P01D81-01EN. In case of the Dual-loop type, please see the General Specifications GS 05P08D81-01EN.)
		/RSP	Non-isolated remote input (please see the General Specifications GS 05P01D31-81EN.)

- \*1: When the /LP option is specified, the RS-485 communication of the Type 2 code "1" is 2-wire system.
- \*2: The type 3 code "3" can be specified only when the Type 1 code is "-0" and the Type 2 code is "0."
- \*3: English, German, French, and Spanish are available for the guide display.
- \*4: The /LP option can be specified in the combination of Type 1 code (any of "-0" or "-1"), Type 2 code (any of "0" or "1") and Type 3 code "0."
- \*5: The /HA option can be specified in the combination of Type 1 code "-0" or "-2." and Type 3 code "0."
- \*6: When the /CT option is specified, the UT32A does not conform to the safety standards (UL and CSA) and CE marking (Products with /CT option are not intended for EEA-market).



บริษัท เอดีดี เฟอร์เนส จำกัด

**ADD FURNACE CO.,LTD.**

44 ซอยบรมราชชนนี 70 ถนนบรมราชชนนี แขวงศาลาธรรมสพน์ เขตทวีวัฒนา กรุงเทพฯ 10170

โทร: 02-888-3472 โทร: ออกแบบ:08-08-170-170 แฟกซ์: 02-888-3258

<https://www.add-furnace.com> E-mail: [sales@add-furnace.com](mailto:sales@add-furnace.com)

### ■ Items to be specified when ordering

Model and suffix codes, whether User's Manual and QIC required.

### ■ Standard accessories

Brackets (mounting hardware), Unit label, Operation Guide

### ■ Special Order Items

Model code	Suffix code	Description
LL50A	-00	Parameter Setting Software
X010	See the General Specifications (*)	Resistance Module

\*: Necessary to input the current signal to the voltage input terminal.

Name	Model
Terminal cover (for UT35A)	UTAP001
Terminal cover (for UT32A)	UTAP002
User's Manual (CD)	UTAP003

### User's Manual

Product user's manuals can be downloaded or viewed at the following URL. To view the user's manual, you need to use Adobe Reader 7 or later by Adobe Systems.

URL: <http://www.yokogawa.com/ns/ut/im/>