



azbil

Specification

FRS100

Multiburner Controller

Overview

The FRS100 Multiburner Controller is a Flame Safeguard control with a self-checking circuit to ensure safe start-up operation. In the case where abnormal conditions exist, the ignition start is prevented and the system is secured by the shut down of combustion at main flame failure during operation.

This compact controller is used with a flame rod or an AUD100C Series Advanced Ultraviolet Flame Detector for batch operation of combustion equipment, and can be mounted on a DIN-specification rail.



Specifications

Applications	Batch operation of oil-fired, gas-fired and oil-gas combination combustion equipment					
Flame Detector To be Used	FRS100B Series	Flame rod: C7007A, C7008A (wiring distance: 30 m min., high frequency coaxial cable: 5C2V or 7C2V) Ultraviolet Flame Detector: C7012A, C *2 (wiring distance: 50 m max., high frequency coaxial cable: 5C2V or 7C2V)				
	FRS100C Series	AUD100C Series Advanced Ultraviolet Flame Detector, C7035A *1, C7027A *1 (wiring distance: 200 m max., Class 1 V 2 mm ² 600 Vac vinyl chloride insulated cable)				
Flame Relay	Standard model	Model No.	Rated Power	Power Consumption	Flame Response	Flame Detector Used
		FRS100B100	100 Vac 50/60 Hz			
	FRS100B200	200 Vac 50/60 Hz				
	FRS100B104	100 Vac 50/60 Hz				
	FRS100B204	200 Vac 50/60 Hz				
	Standard model	FRS100C100	100 Vac 50/60 Hz	7 W max.	3 ± 1 s (at 2 V flame voltage)	Flame Rod C7007A, C7008A , Ultraviolet Flame Detector C7012A , C *2
		FRS100C200	200 Vac 50/60 Hz			
		FRS100C104	100 Vac 50/60 Hz			
		FRS100C204	200 Vac 50/60 Hz			
	High sensitivity model	FRS100C150	100 Vac 50/60 Hz	7 W max.	3 ± 1 s (at 4.2 V flame voltage)	Advanced Ultraviolet Flame Detector AUD100C+AUD15C , AUD110C+AUD15C Minipeeper Ultraviolet Flame Detector C7035A *1, C7027A *1
		FRS100C250	200 Vac 50/60 Hz			
		FRS100C154	100 Vac 50/60 Hz			
FRS100C254		200 Vac 50/60 Hz				
Contact Rating	250 VA (terminals ③ - ④, ③ - ⑧)					
Flame Sensitivity	Ignition detection level: Flame voltage 1 V max. Flame-out detection level: FRS100B Series (flame voltage 0.2 V min.) FRS100C Series (flame voltage 0.4 V min.)					
Flame Signal Output	0 to 5 Vdc, wiring distance 10 m max. (use a shielded cable), output terminals: A(-) and B(+) on body. Input impedance of externally connected equipment: 100 KΩ min.					
Ambient Temperature	-20 to +60 °C (Only 1 unit mounted), -20 to +45 °C (Gang-mounted over 2 units)					
Ambient Humidity	90%RH, 40 °C (no condensation allowed)					
Vibration Resistance	4.9 m/s ² max., 10 to 60 Hz for 2 hours each in X, Y and Z directions (when screw mounted)					
Insulation Resistance	50 MΩ min. between each terminal and ground terminal by 500 Vdc megger					
Dielectric Strength	1500 Vac for 1 min between each terminal and ground terminal, or no failure after applying 1800 Vac for 1 sec (excluding flame detector input terminals ⑤ and ⑥)					
Induction Lightning Surge	10 kV, 1.2 × 50 μs (JEC-187, surge impedance 75 Ω min.) when surge absorber listed below is mounted between terminal ② and ground: * Recommended surge absorber: Specification Sheet No. 10013 (Part No. 83968019-001)					
Life	100,000 operations (at room temperature/humidity and rated voltage)					
Body Color	Gray					
Mounting	Mounted on DIN rail or screw mounted					
Mass	FRS100B, C: approx. 270 g, mounting subbase FRS50A: approx. 70 g					
Accessories (Order separately)	FRS50A100	Mounting subbase				
	FRS60A	Flame meter				
	FSP300C100	Flame simulator for AUD100C Series, C7035A *1, C7027A *1				
	123514A	Flame simulator for flame rod, C7012A, C				
	83968019-001	Lighting surge absorber				

*1 Discontinuation date: Dec. 2011.

*2 Discontinuation date: March 2012.

This flame relay is equipped with extremely important functions for ensuring flame safeguard. When planning the flame safeguard control systems, please consult an Azbil Corporation sales representative for the explanation of detail specifications.



Burner Flame Monitoring Terminal Connections

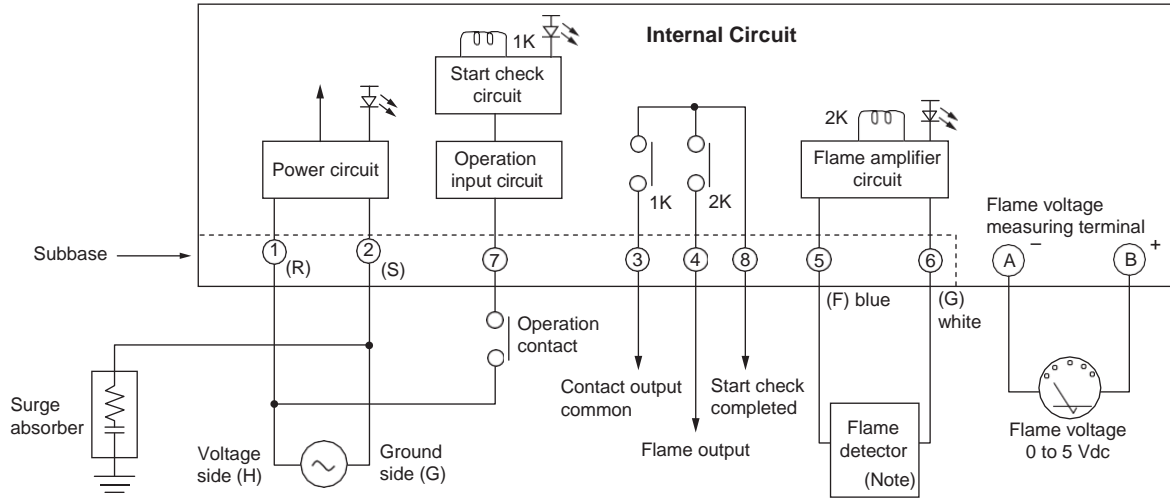

Note) • Flame rod

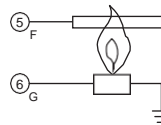

• AUD100C Series Advanced Ultraviolet Flame Detector

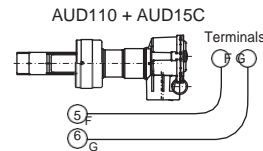

Operation Chart

• Normal Operation

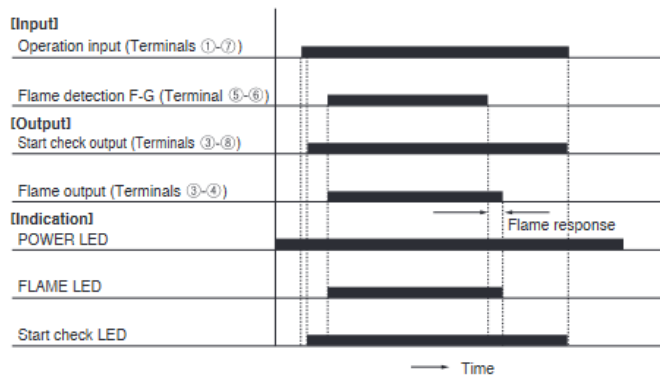

• False Flame Operation

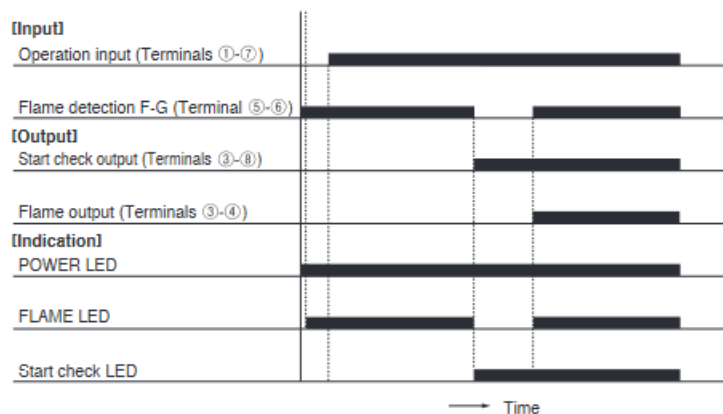



Manual Ignition (Intermittent Pilot)

Terminal Connections

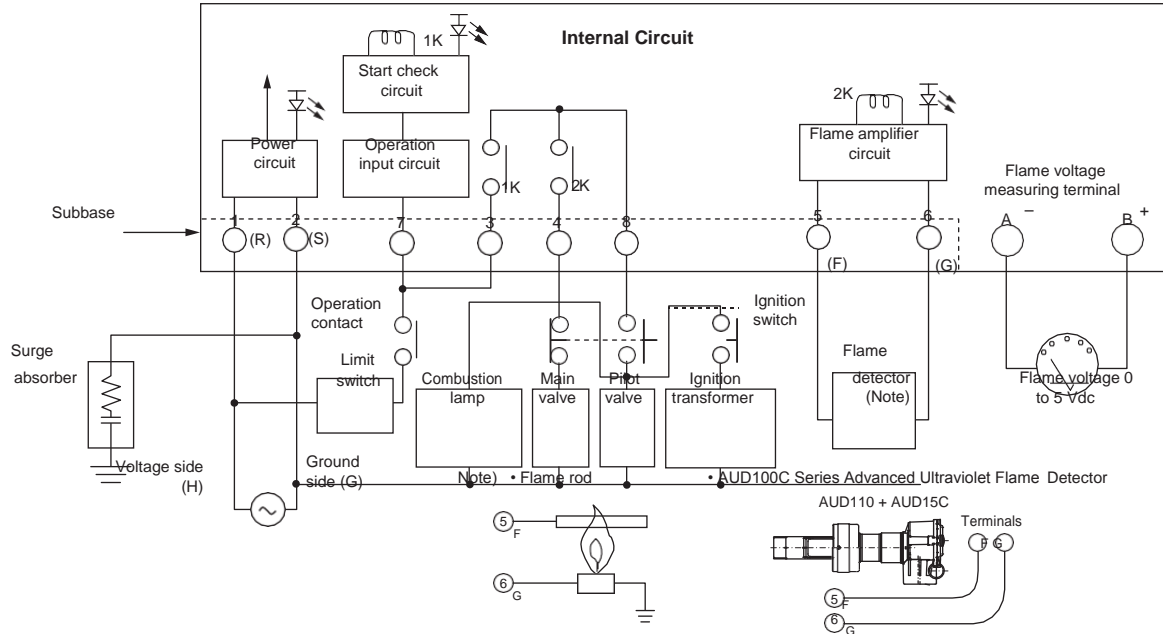

Operation Chart

• Normal Operation



• False Flame Operation

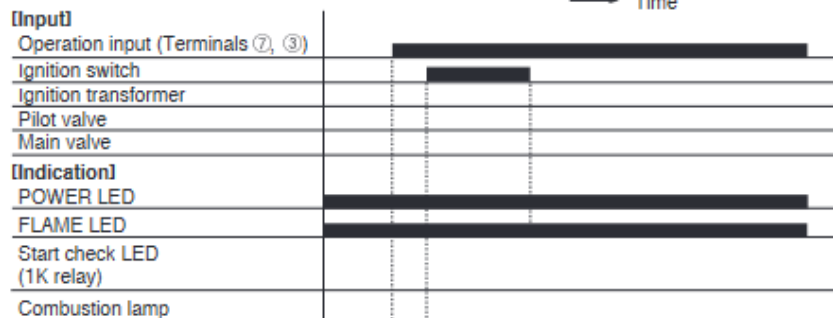

• Flame Failure Operation

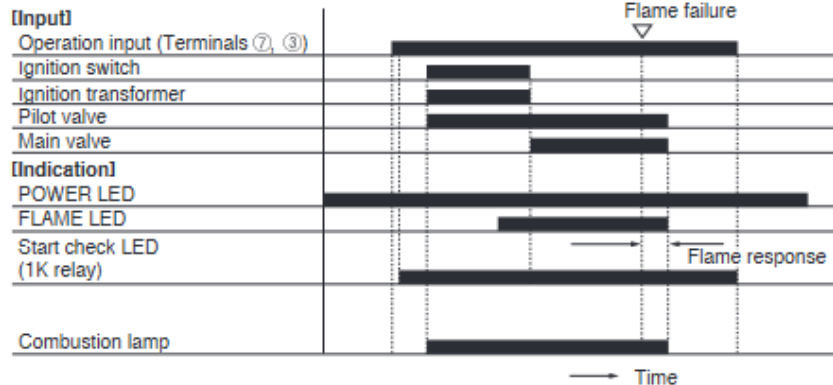



External Dimensions

(Unit: mm)

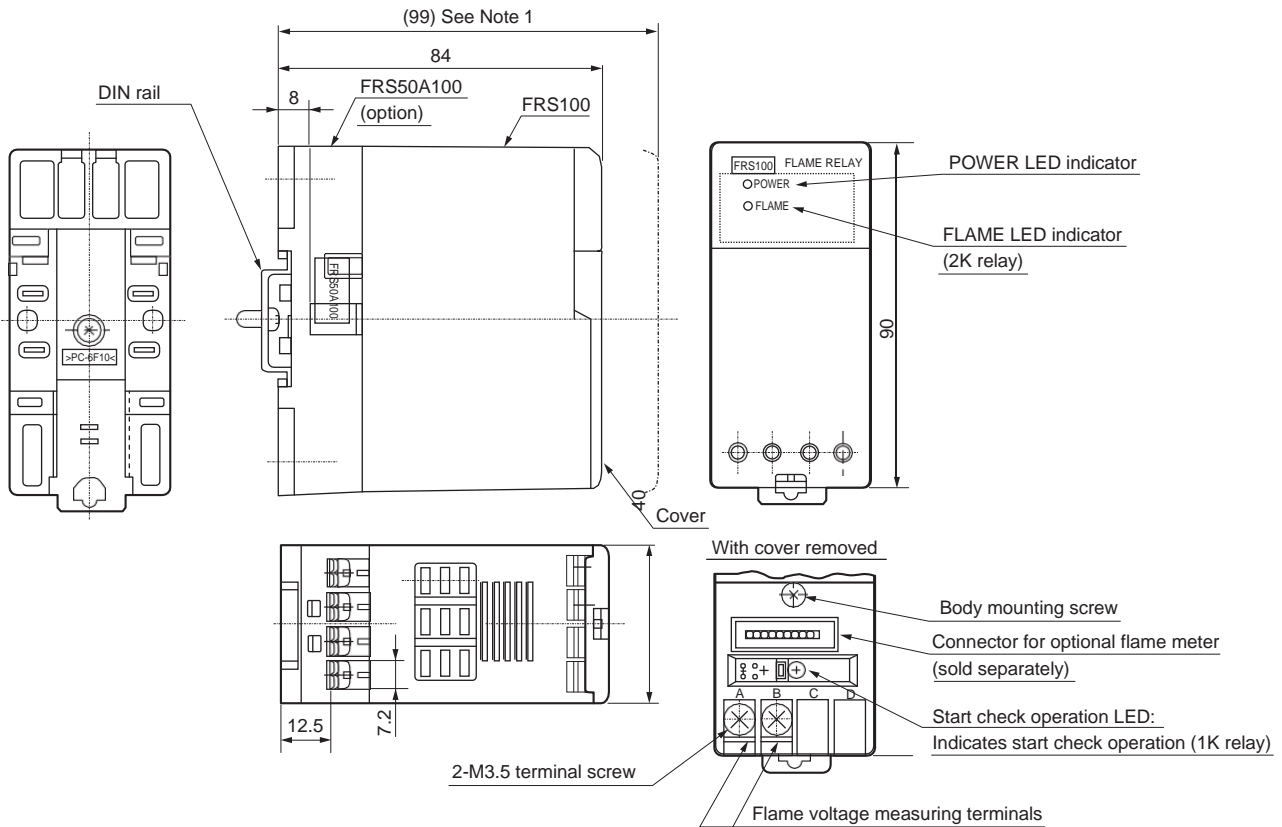

Mounting Subbase (separate order)

Model No.: FRS50A100

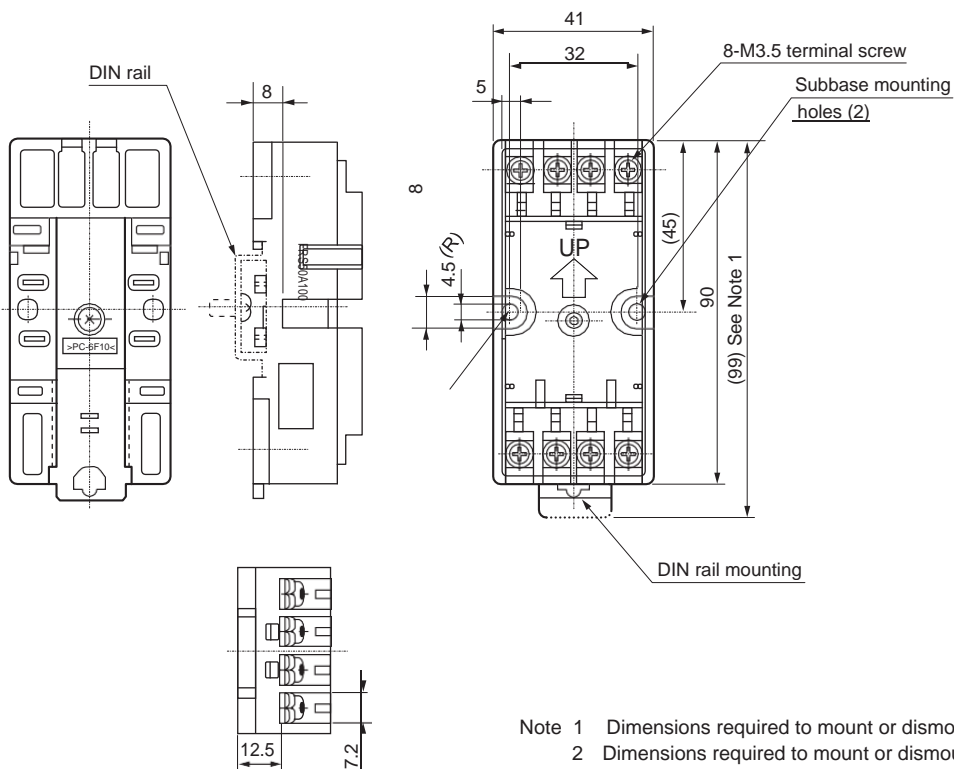

- Note 1 Dimensions required to mount or dismount the main body.
- 2 Dimensions required to mount or dismount on the DIN rail.
- 3 The above external drawing shows the FRS100 flame relay mounted on the FRS50A100 subbase.



บริษัท เอดีดี เฟอร์เนส จำกัด

ADD FURNACE CO.,LTD.

44 ซอยบรมราชชนนี 70 ถนนบรมราชชนนี แขวงศาลาธรรมสพน์ เขตทวีวัฒนา กรุงเทพฯ 10170

โทร: 02-888-3472 โทร: ออกแบบ:08-08-170-170 แฟกซ์: 02-888-3258

<https://www.add-furnace.com> E-mail: sales@add-furnace.com

Troubleshooting

Troubleshooting can be performed in combination with the following LED lighting indications:

○ LED OFF
● LED ON

	POWER LED	Start check LED	FLAME LED	Results	Check Items
Before Start-up	○	○	○	Power is not ON.	Check panel power switch and wiring
After Start-up	●	●	●	Flame is being detected. (normal operation)	—
	●	●	○	Flame is not detected.	Check flame detector, burner, valve, ignition transformer and flame relay
	●	○	●	False flame	Check burner flame, flame sensor and flame relay
	●	○	○	1K relay is not ON.	Check power supply at start-up input terminal ⑦ and flame relay



บริษัท เอดีดี เฟอร์เนส จำกัด

ADD FURNACE CO.,LTD.

44 ซอยบรมราชชนนี 70 ถนนบรมราชชนนี แขวงศาลาธรรมสพน์ เขตทวีวัฒนา กรุงเทพฯ 10170

โทร: 02-888-3472 โทร: ออกแบบ:08-08-170-170 แฟกซ์: 02-888-3258

<https://www.add-furnace.com> E-mail: sales@add-furnace.com

Cautions

- (1) Before wiring, be sure to turn the power OFF. Touching terminals by mistake with the power ON might cause an electric shock or malfunction.
- (2) After wiring, be sure to check the wiring connections. Incorrect wiring may cause damage or malfunction.
- (3) Make sure that ignition transformer high-voltage cables are properly connected in order to prevent faulty contacts. Faulty contacts may cause high-frequency noise, resulting in malfunction.
- (4) Do not bundle the power leads and ignition transformer high-voltage cables together with the flame detector lead wires, nor place them in the same conduit. In particular, keep ignition transformer high-voltage cables at least 10 cm away from the flame relay and wire separately.
- (5) Do not mount the flame relay at the following locations:
 - Locations near special chemicals or surrounding atmospheres (ammonia, sulfur, chlorine, ethylene compounds, acid, etc.)
 - Locations subject to water spray
 - Locations subject to high temperatures
 - Locations subject to continuous vibration
- (6) Wire external leads between the power supply terminals (100 V or 200 V and 0 V) of the flame relay so that power is applied at all times from the moment when the power switch is turned ON. This wiring is necessary to ensure operation of the self-start checking circuit at start-up.
- (7) Connect terminals F and G of the AUD110C Advanced Ultraviolet Flame Detector to terminals ⑤ and ⑥ respectively. In the case of the AUD100C, connect the blue signal lead and white signal lead to terminals ⑤ and ⑥, respectively. Turning on the power when the flame detector is incorrectly wired can damage the AUD15C tube unit.
- (8) Do not transport the flame relay mounted on the DIN rail. Before transporting, remove it from the subbase and pack in a dedicated packing case.
If the flame relay is transported when mounted on the DIN rail, it may detach and become damaged.
- (9) The flame relay is not provided with pre-purge timer and sequence functions necessary for burner ignition. Therefore, take the timer and sequence functions into consideration when designing your control system.
- (10) Do not connect the solenoid valve to the voltage side. When a ground fault occurs, ground current flows to the solenoid valve to open the valve and cause the fuel to flow, regardless of the flame relay operation.
- (11) In the case of the high sensitivity models, flame voltage should be less than 4.5 V.