

Flansch-Kugelhähne aus Sphäroguß

Flange-ball valves in spheroidal graphite cast iron

Baureihe
KSN 75

voller Durchgang DN 25 - DN 150
full port design DN 25 - DN 150

PN 16



Konstruktions-Merkmale

Bauart:

- zweiteiliges Gehäuse, verschraubt
- voller Durchgang
- Fire - Safe Design
- TA-Luft
- HTB geprüft nach DIN EN 1775 bis DN100 PN16
DN125 - DN150 PN5
- schwimmende Kugel
- silikonfrei

Aufbauten:

- Montageflansch nach DIN ISO 5211
- lieferbar mit elektrischem oder pneumatischem Drehantrieb
- Direktaufbau möglich

Baulänge:

DIN EN 558-1 Reihe 14

Kugeldichtung:

- 3 - seitige Kammerung

Schaltwelle:

- ausblassicher

Dichtflächen:

DIN EN 1092-2 B1

andere Dichtflächen auf Anfrage

Flanschanschlußmaße:

DIN EN 1092-2 PN 16

Korrosionsschutz Standard:

Grundierung aus 1 K Wasserbasislack
Sonderlackierungen siehe Preisliste S. 32 oder auf Anfrage

Verwendung:

Gas: Brenngase der 1., 2. und 3. Gasfamilie

Druckgeräterichtlinie:

- Gas-Zulassung nach DIN EN 13774
DIN DVGW NG-4313AT0309
- GAR (EU/2016/426) CE 0085 AT0437
- PED (2014/68/EU) CE 0035

Hinweis:

Kugelhahn DN 150 kann nur bei geöffneter Kugel ein- bzw. ausgebaut werden

Design features

design:

- 2-piece ball valve „screwed design“
- full port design
- fire - safe design
- TA-Luft
- HTB certified acc. to DIN EN 1775 up to DN100 PN16
DN125-DN150 PN5
- floating ball
- free of silicone

mounting:

- mounting flange acc. to DIN ISO 5211
- available with electrical or pneumatic actuators

- direct mounting possible

length face to face:

DIN EN 558-1 line 14

ball seal:

- triple side covered

stem:

- blow out proof stem design

faces:

DIN EN 1092-2 B1

other face types on request

flange dimensions:

DIN EN 1092-2 PN 16

corrosion protection standard version:

grounding 1 K water-based varnish
other paintings see price list page 32 or on request

suitable for:

gas: 1., 2. and 3. gas category

pressure equipment directive:

- Gas-Zulassung nach DIN EN 13774
DIN DVGW NG-4313AT0309
- GAR (EU/2016/426) CE 0085 AT0437
- PED (2014/68/EU) CE 0035

remarks:

ball valve DN 150 can only be installed or removed with ball in open position

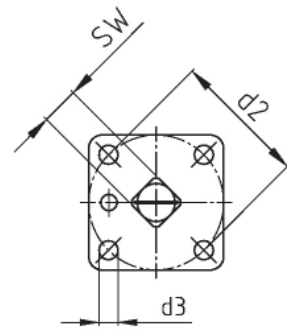
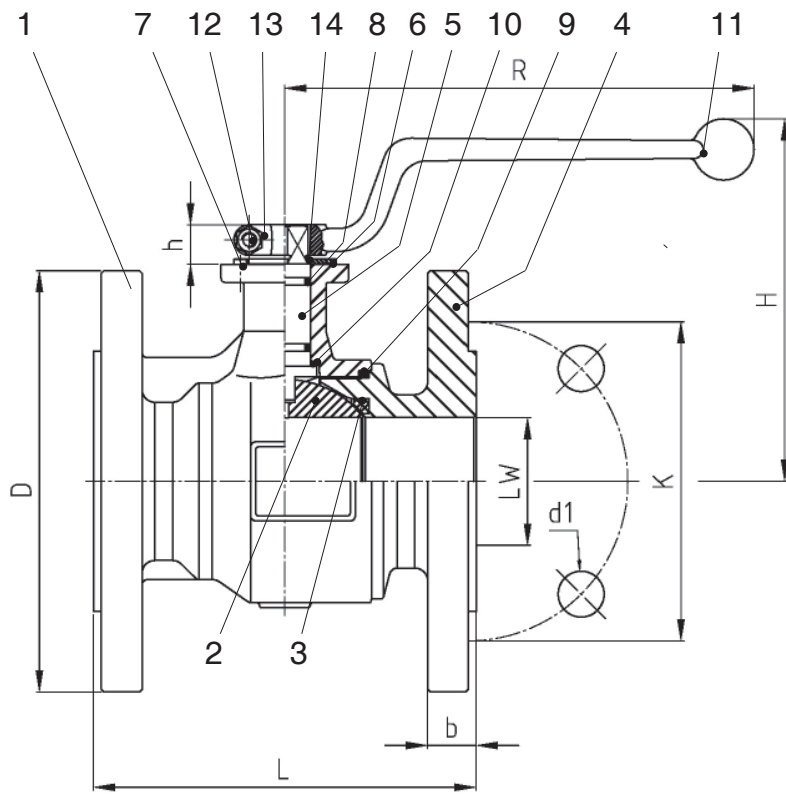

**Montageflansch
mounting flange**

Temperaturbereich
Gas -20°C bis + 60°C

working temperature
Gas -20°C to + 60°C

Nr./no	Bezeichnung	description	Werkstoff	material	Material Bezeichnung	
1	Gehäuse	body	Sphäroguß	spheroidal graphite cast iron	GJS 400-18-LT	
2	Kugel (hohl) (voll)	ball (hollow) (solid)	B	Stahl verchromt	steel chrome plated	C 45
			E	Edelstahl	stainless steel	1.4301
			F	Edelstahl	stainless steel	1.4408
3	Kugeldichtung	ball seal	Teflon	Teflon	PTFE	
4	Flansch	flange	Sphäroguß	spheroidal graphite cast iron	GJS 400-18-LT	
5	Schaltwelle	stem	Edelstahl	stainless steel	1.4104	
6	Anschlagscheibe	stop washer	Stahl verzinkt	steel zinc plated	-	
7	Kerbstift	stop pin	Stahl verzinkt	steel zinc plated	-	
8	O-Ring	O-Ring seal	Viton	Viton	FKM	
9	O-Ring	O-Ring seal	Viton	Viton	FKM	
10	Anlaufring	bearing ring	Polyamid	polyamid	-	
11	Griff	handle	Alu (gelb)	Alu yellow anod.	-	
12	Zyl. Schraube	bolt	Stahl verzinkt	steel zinc plated	-	
13	Skt. Mutter	nut	Stahl verzinkt	steel zinc plated	-	
14	Sprengring	snap ring	Edelstahl	stainless steel	1.4310	

**Bestellangaben
Baureihe - DN - PN - Bauart**



**Bestellbeispiel:
KSN 75 - 50 - 16 - B**

**ordering dates
series - DN - PN - type**

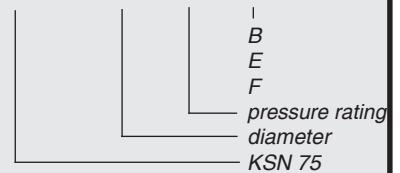

**ordering data:
KSN 75 - 50 - 16 - B**

z = Anzahl der Flanschlöcher, number of flange holes

Maße in mm, dimensions in mm

DN	LW	L	D	K	h	b	z	d1	H ~	R ~	Montageflansch mounting flange DIN ISO 5211	SW	d2	d3	Gewicht - weight ~ kg		
															B	E	F
25	25	125	115	85	14,5	16	4	14	111,5	165	F 05	11	50	6,6	3,300	3,300	3,300
32	32	130	140	100	14,5	16	4	18	122,5	165	F 05	11	50	6,6	4,700	4,700	4,700
40	40	140	150	110	16,5	19	4	18	134,0	185	F 05	14	50	6,6	5,700	5,700	5,700
50	50	150	165	125	16,5	19	4	18	142,0	185	F 05	14	50	6,6	7,600	7,200	7,600
65	65	170	185	145	18,0	19	4	18	154,5	230	F 07	17	70	9	12,000	10,800	12,000
80	80	180	200	160	22,5	19	8	18	180,5	360	F 07	22	70	9	15,500	13,400	15,500
100	100	190	220	180	22,5	19	8	18	197,0	360	F 10	22	102	11	22,600	18,000	22,600
125	125	200	250	210	25,0	22	8	18	216,0	360	F 10	22	102	11	30,400	22,000	30,400
150	142	210	285	240	28,0	22	8	22	236,0	556	F 10	27	102	11	42,000	32,000	42,000