

Pressure regulator FRNG

Zero pressure regulator Proportional pressure regulator Compressed air-control- led pressure regulator

DUNGS[®]
Combustion Controls

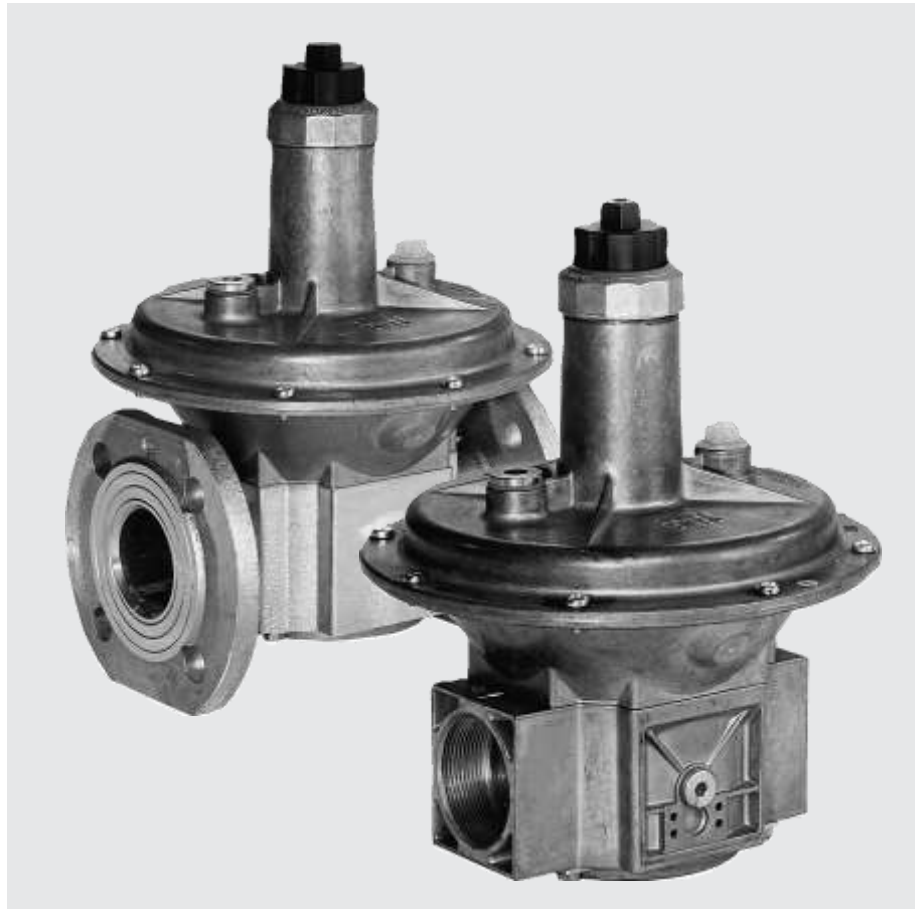

Technical description

The DUNGS pressure regulator, type FRNG, has an adjustable setpoint spring and defined counterspring. The pressure regulator complies with EN 88-1 and DIN 3380:

- **Input pressures up to 200 mbar (20 kPa) for zero pressure applications**
- **Input pressures up to 200 mbar (20 kPa) for proportional pressure applications**
- Bypass prepared, Rp 3/8 to Rp 2
- Sturdy, precise and sensitive regulation of regulator output pressure
- Inlet pressure compensation diaphragms
- Safety diaphragms
- Internal pulse for regulator output pressure as standard, external pulse connection prepared

- Connection for blower pressure as standard

Application

The DUNGS pressure regulator, type FRNG, is suitable for gases of families 1, 2, 3 and other neutral gaseous media. Does not contain any non-ferrous metals, suitable for gases of up to max. 0.1 vol.% H₂S, dry.

Approval

EC type testing certificate as per:
• EC-Gas Appliances Regulation
Approvals in other important gas consuming countries.

FRNG Spring-loaded pressure regulator with adjustable setpoint spring and defined counterspring. Internal tap of regulator output pressure, external pulse and blower pressure connections prepared. Suitable for controlling regulator output pressure via a pneumatic command variable.

Specifications

Nominal diameters	DN	40 50 65 80 100 125 150
Pipe thread as per ISO 7/1	Rp	3/8 1/2 3/4 1 1 1/2 2
Flange	Connection flange (PN 16) per DIN EN 1092-1	
Max. operating pressure	up to 500 mbar (50 kPa)	
Pressure regulator	Pressure regulator as per EN 88-1, Class A, Group 2, DIN 3380 RG 10, EN 12078	
Input pressure range		
Zero pressure regulator	5 to 200 mbar (0.5 to 20 kPa)	
Proportional pressure regulator	5 to 200 mbar (0.5 to 20 kPa)	
Compressed air-controlled pressure regulator	to 500 mbar (50 kPa)	
Output pressure range	Zero pressure regulator -3 to 5 mbar (-0.3 to 0.5 kPa) Proportional pressure regulator -10 to 200 mbar (-1 to 20 kPa) Pressure with compressed air up to max. 350 mbar (35 kPa).	
Materials of gas-conveying parts	Housing: aluminium, steel, no non-ferrous metals Seals and diaphragms: NBR	
Ambient temperature	-15 °C to +70 °C	
Installation position	<ul style="list-style-type: none"> Regulator dome from vertically upright to lying horizontally Rp 3/4 - DN 100 Regulator dome in vertical position DN 125, DN 150 Regulator dome overhead Rp 3/4 - DN 150 (Zero pressure regulator) 	
Measuring/ignition gas connections	G 1/4 ISO 228 on both sides in inlet section	
Measurement opening	G 1/4 ISO 228 in the baseplate (option DN 125, DN 150) Reclosable opening for setting system-specific values when the system is put into operation, e. g. gas motor	
Bypass	Bypass prepared: Rp 3/4 to Rp 2 on right of housing	
Pulse connection	Internal in outlet section, externally prepared on housing: Rp 3/4 to Rp 1 left, G 1/4; on both sides from Rp 1 1/2, DN 40 G 1/4; internal pulse lockable	
Ventilation line / pressure connection for blower pressure	Ventilation line needs no routing, use existing connection as pressure connection for command variable (blower pressure). Connection: G 1/4 to Rp 1; from Rp 1 1/2, DN 40: G 1/2	
Blower pressure command variable	For proportional pressure applications and gas-air ratio applications at pressure ratio of approx. 1:1 and in compressed-air controlled operation: $p_{max} = 150$ mbar (15 kPa)	

Spring selection

The output pressure is provided by the force of the installed adjustable spring, the counterspring and the the blower pressure applied. The pressure

regulator is equipped with the brown spring No. 1 as standard. By exchanging the adjustable spring, it is possible to achieve larger positive zero point

shifts (offsets) of the output pressure (refer to Fig. Compressed air-controlled pressure regulator).

Installation position	over-head	Vertically upright to lying horizontally								
		0-pres-sure	0-pres-sure	5...13	5...20	10...30	25...55	30...70	60...110	100...150
Setpoint spring range [mbar]	0-pres-sure	0-pres-sure	5...13	5...20	10...30	25...55	30...70	60...110	100...150	140...200
Numbering of the springs	spring 3	spring 1	spring 2	spring 3	spring 4	spring 5	spring 6	spring 7	spring 8	spring 9
Spring colour	orange	brown	white	orange	blue	red	yellow	black	pink	grey
Nominal diameter Rp/DN	Standard		Spring 2...9 for compressed applications only							
	Rp ,Rp1/2	229 820	229 817	229 818	229 820	229 821	229 822	229 823	229 824	229 825
Rp 3/4	229 835	229 833	229 834	229 835	229 836	229 837	229 838	229 839	229 840	229 841
Rp 1	229 844	229 842	229 843	229 844	229 845	229 846	229 847	229 848	229 849	229 850
Rp 1 1/2, DN 40	229 853	229 851	229 852	229 853	229 854	229 869	229 870	229 871	229 872	229 873
Rp 2, DN 50	229 876	229 874	229 875	229 876	229 877	229 878	229 879	229 880	229 881	229 882
DN 65, DN 80	229 885	229 883	229 884	229 885	229 886	229 887	229 888	229 889	229 890	229 891
DN 100	229 894	229 892	229 893	229 894	229 895	229 896	229 897	229 898	229 899	229 900
DN 125	229 903	229 901	229 902	229 903	229 904	229 905	229 906	229 907	229 908	243 416
DN 150	229 911	229 909	229 910	229 911	229 912	229 913	229 914	229 915	229 916	243 417

Standard Offset ≤ 5 mbar (Closing force of counterspring in closed position)

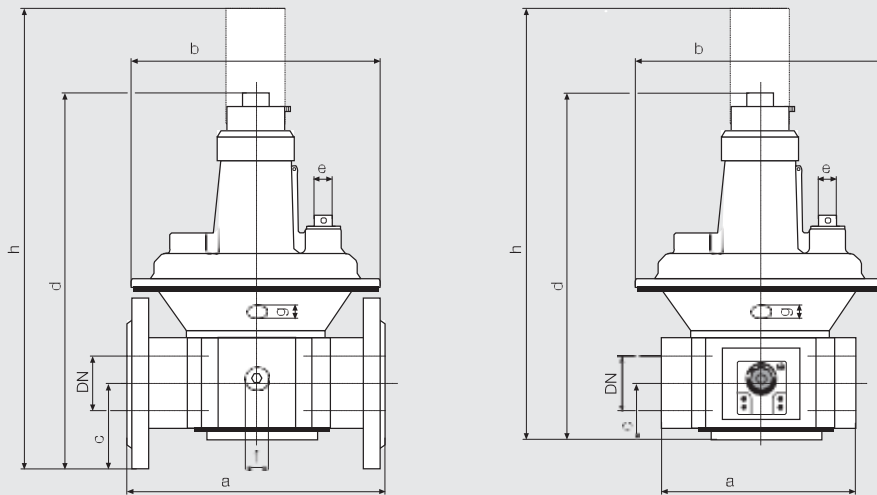
Dimensions

Type	Order No.*	Order No.**	p _{max.}	Rp / DN							Weight		
FRNG 503	220 967	290 044	500	Rp 3/8	77	115	24	143	G 1/4	G 1/4	G 1/8	225	0,60
FRNG 505	220 968	290 045	500	Rp 1/2	77	115	24	143	G 1/4	G 1/4	G 1/8	225	0,60
FRNG 507	220 969	290 046	500	Rp 3/4	100	130	28	165	G 1/4	G 1/4	G 1/8	245	1,00
FRNG 510	220 970	290 047	500	Rp 1	110	145	33	190	G 1/4	G 1/4	G 1/8	310	1,20
FRNG 515	209 064	290 048	500	Rp 1 1/2	150	195	40	250	G 1/2	G 1/4	G 1/4	365	2,50
FRNG 520	209 065	290060	500	Rp 2	170	250	47	310	G 1/2	G 1/4	G 1/4	450	3,50
FRNG 5040	159 350	290 061	500	DN 40	200	195	75	280	G 1/2	G 1/4	G 1/4	395	3,50
FRNG 5050	209 067	290 062	500	DN 50	230	250	82,5	340	G 1/2	G 1/4	G 1/4	480	5,00
FRNG 5065	209 068	290 063	500	DN 65	290	285	92,5	405	G 1/2	G 1/4	G 1/4	590	7,50
FRNG 5080	209 069	290 064	500	DN 80	310	285	100	405	G 1/2	G 1/4	G 1/4	590	10,00
FRNG 5100	214 422	290 065	500	DN 100	350	350	110	495	G 1/2	G 1/4	G 1/4	760	16,00
FRNG 5125	220 758	290 066	500	DN 125	400	400	125	635	G 1/2	G 1/4	G 1/4	1000	28,00
FRNG 5150	224 212	290 067	500	DN 150	480	480	142,5	780	G 1/2	G 1/4	G 1/4		
Bypass restrictor	225 256			Rp3/8-Rp2									

* Installation position vertically upright to lying horizontally

3 ... 8 ** Installation position overhead (atmospheric pressure regulator)

Functional description

Functions according to the force comparison principle between the force of:

- the adjustable setpoint spring
- the defined counterspring
- the differential pressure at the working diaphragm and
- the force due to weight of the moving parts

The counterspring acts against the adjustable spring and the weight due to force of the moving parts. Depending on the pretension of the adjustable spring and the installation position, the force of

the counterspring is compensated. Overcompensation leads to positive regulator output pressures, partial compensation leads to negative regulator output pressures.

Instructions

Gas-conveying lines, pulse and connection lines must be made of steel and at least PN 1, DN 6. The lines must be resistant to thermal, chemical and mechanical loads. The lines must be durable and deformation- and crack-proof.

⚠ Do not route condensate from lines into the pressure regulator.

⚠ Do not apply burning gas or combustion gas air mixtures to the installation chamber of the adjustable spring.

**FRNG 515 sectional drawing
 Pressure regulator in closed position**

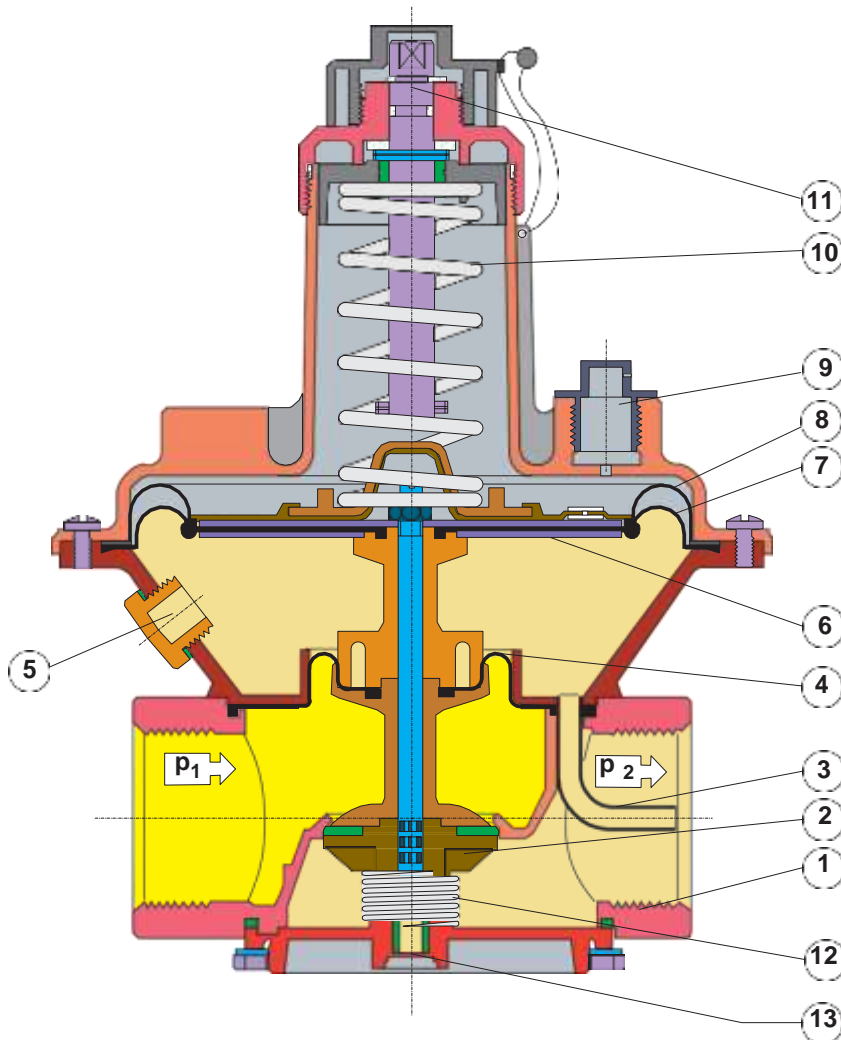

1	Housing	6	Diaphragm disk	11	Adjustment device
2	Regulating cup	7	Working diaphragm	12	Counterspring
3	Pulse tap, internal	8	Safety diaphragm	13	Option DN 125, DN 150 Measurement opening with screw plug G 1/8
4	Compensation diaphragm	9	Breathing plug		
5	External pulse	10	Setpoint spring		

Application of zero pressure regulator (standard design)

The FRNG regulates a gas flow proportional to the consumer vacuum for gas motors and self-intaking gas equipment.

The regulator is adjusted within the setting range at the setpoint spring.

$$\dot{V}_{min.} = \dot{V}_{max.} \times 0.1$$

For $\dot{V}_{max.}$, see volumetric flow pressure drop characteristic.

Installation position vertically upright to lying horizontally:

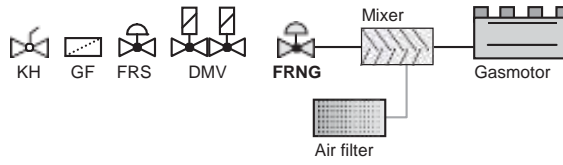

Installation position overhead:

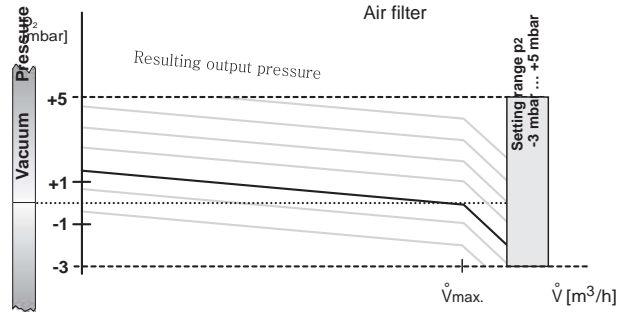
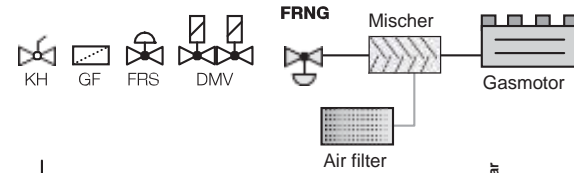

Application with compressed air-controlled pressure regulator (standard design)

For externally controlled gas equipment.

In connection with a selected setpoint spring, the regulator output pressure can be controlled depending on the blower pressure (compressed air). The command variable can be up to +150 mbar.

$$\dot{V}_{min.} = \dot{V}_{max.} \times 0.05$$

For $\dot{V}_{max.}$, see volumetric flow pressure drop characteristic.

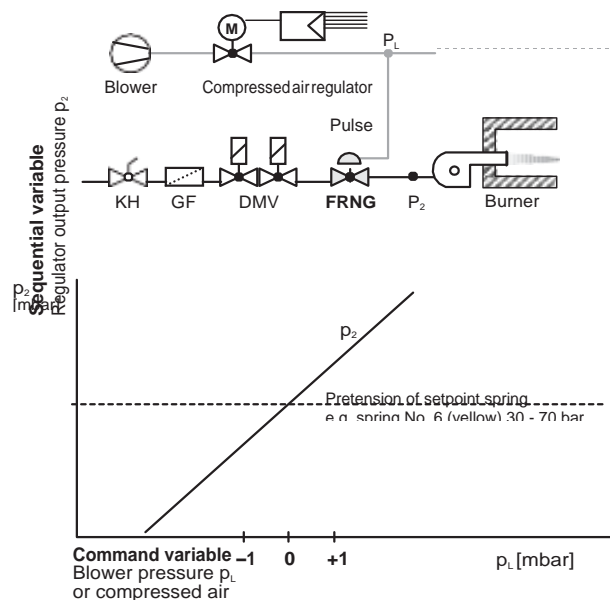

Pressure taps Pulse and blower connection

- 1 Breathing plug or connection for ventilation line. Only route ventilation line in special cases or connection for air pulse line
- 2 Connection for external gas pulse. Internal pulse must be closed.
- 3 Pressure connection in inlet section G 1/4 ISO 228 screw plug, Rp 3/8 to Rp 2 with bypass cover prepared for mounting adjustable bypass restriction.

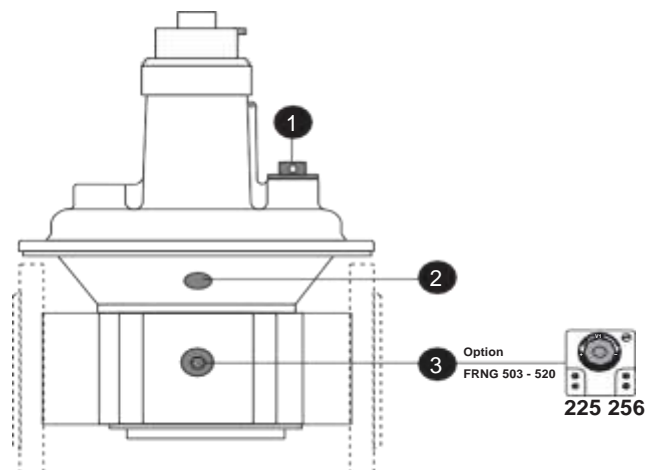

Application of proportional pressure regulator (standard design)

Asproportional pressure regulator for gas-air ratio regulators with fixed efficiency pressure ratio $V = 1:1$ on gas equipment operated with differential pressure.

The offset range of the counterspring can be set by the setpoint spring. The moving parts are compensated by the force due to weight.

Gas supply or air supply are adjustable at full load and partial load.

Basic load is adjustable via bypass restrictor.

The command variable can be up to +150 mbar.

 $\dot{V}_{min.} = \dot{V}_{max.} \times 0,05$

For $\dot{V}_{max.}$ see volumetric flow pressure drop characteristic.

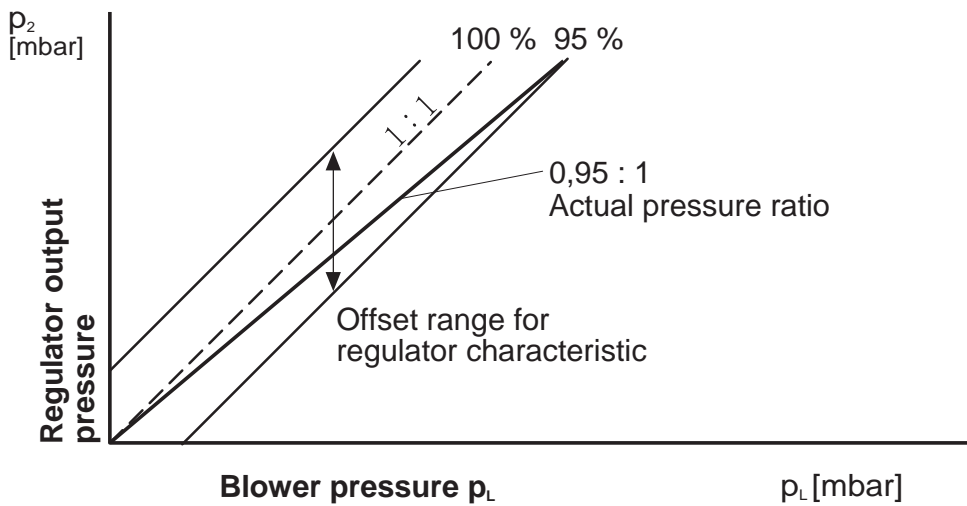
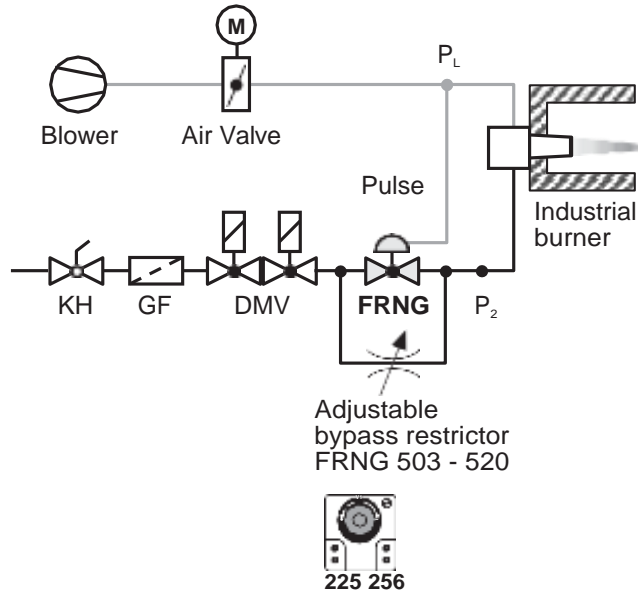

Volumetric flow pressure difference characteristic
Bypass restrictor

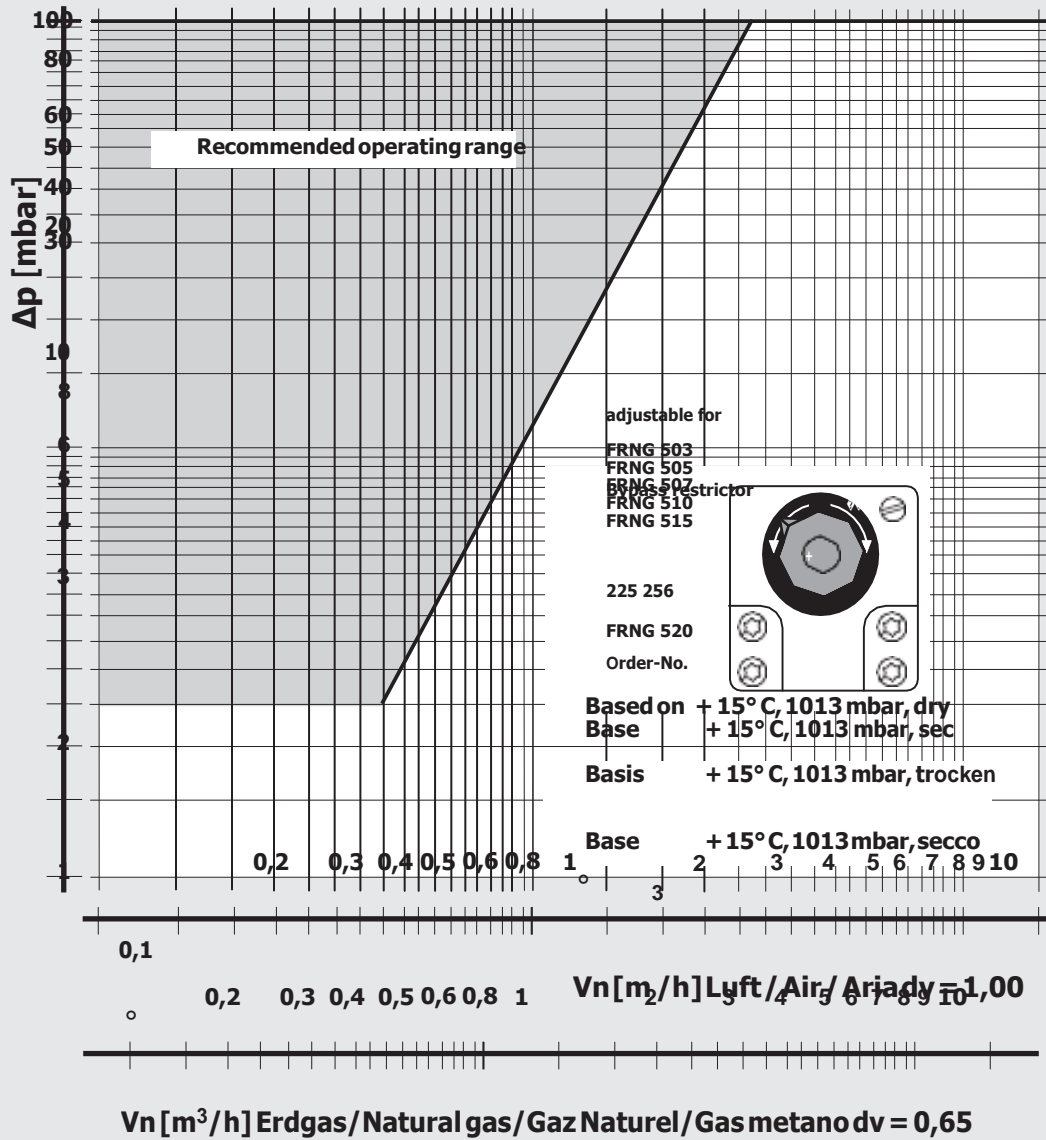

**Pressure regulator
 FRNG**

**Zero pressure regulator
 Proportional pressure regulator
 Compressed air-controlled
 pressure regulator**



Volumetric flow pressure loss characteristic

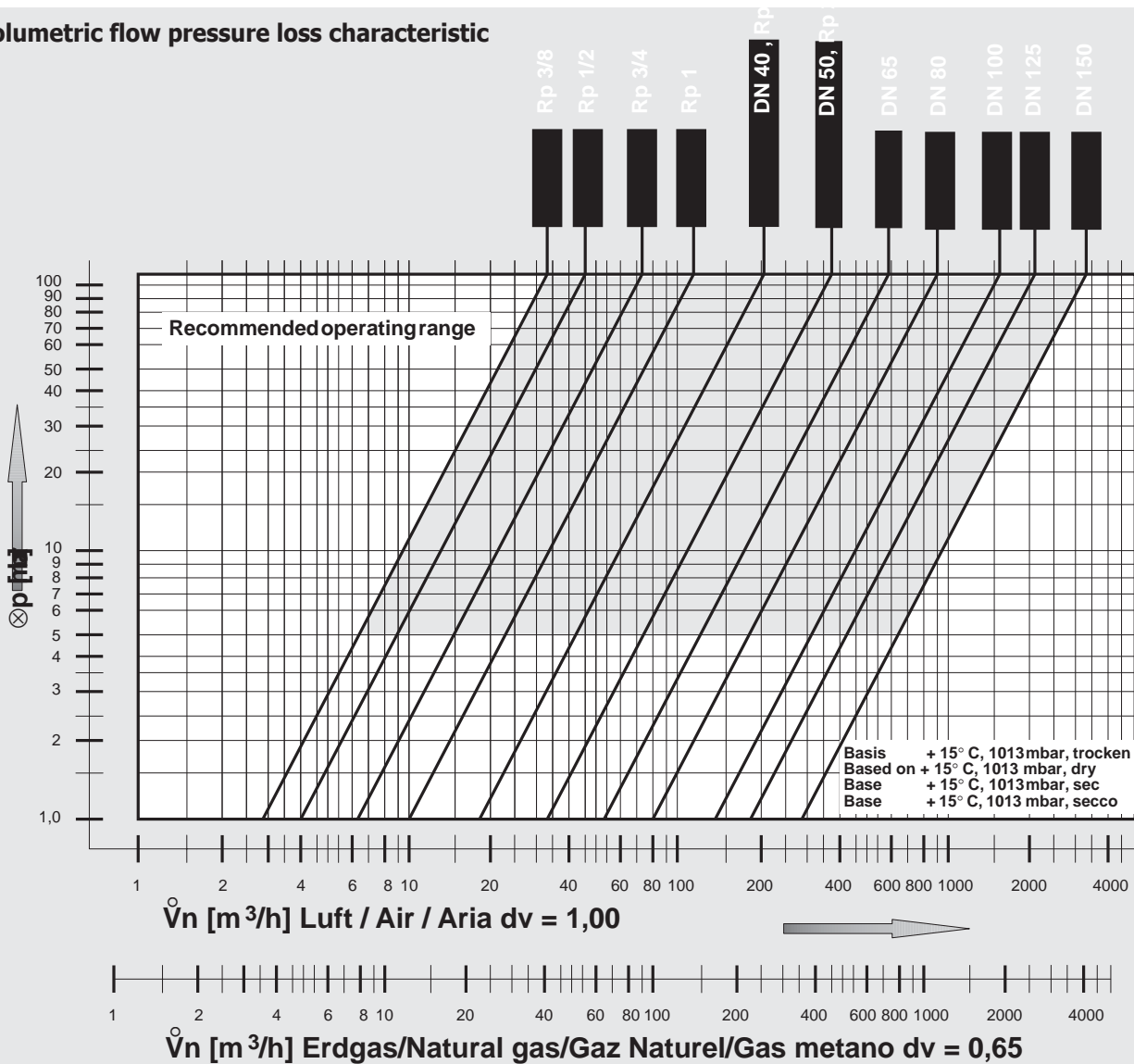

We reserve the right to make any changes in the interest of technical progress.