

## GasMultiBloc® Combined regulator and **safety shut-off** valves Two-stage function

**MB-ZRD(LE)405-412B01**

**DUNGS®**  
Combustion Controls

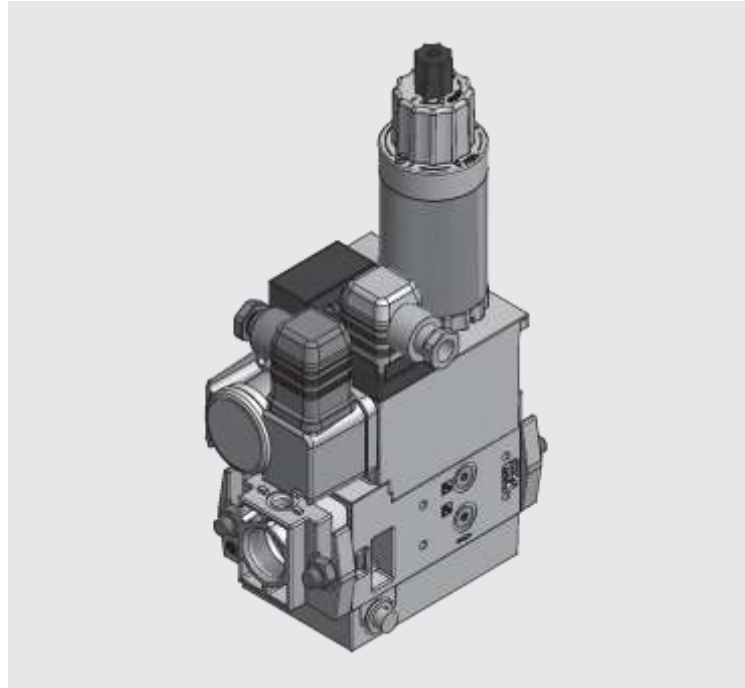

### Technical description

The DUNGS GasMultiBloc® integrates filter, regulator, valves and pressure switches in one compact fitting.

- Dirt trap: Fine-mesh sieve
- One regulator and two main valves: B01
- One one-stage valve and one two-stage valve
- One valve is fast opening, one valve is slow or fast opening
- Solenoid valves up to 360 mbar (36 kPa) as per DIN EN 161 Class A Group 2
- Sensitive setting of output pressure by proportional regulator as per DIN EN 88 Class A Group 2
- High flow rates with low pressure drop
- DC solenoid drive interference degree N
- Main volume restrictor and partial volume restrictor at valve V2
- Hydraulic opening delay
- Flange connections with pipe threads as per ISO 7/1
- Simple mounting, compact, light-weight

The modular system permits individual solutions by using external ignition gas tap in connection with separately controlled valves, by adding a valve proving system, mini/maxi pressure switches, pressure limiters, limit switch and closing stroke limiter at valve V2, regulator blocking for liquid gas applications.

### Application

The modular system permits individual solutions in gas safety and regulator engineering. Suitable for gases of families 1, 2, 3 and other neutral gaseous media.

### Approvals

EC type test approval as per EC Gas Appliance Directive:  
MB-ZR...405-412 B01 CE-0085 AP 3156  
EC type test approval as per EC Pressure Equipment Directive:  
MB-ZR...405-412 B01 CE0036  
Approvals in other important gas consuming countries.

**Specifications**

Nominal diameters Flange with pipe threads as per ISO 7/1 (DIN2999)	MB-ZR...405/407 B01 Rp 1/2, 3/4 and their combinations	MB-ZR...410/412 B01 Rp 3/4, 1, 1 1/4 and their combinations																				
<b>Max. operating pressure</b>	<b>360 mbar (36 kPa)</b>																					
<b>Output pressure ranges</b>	<b>MB-... S20/S22 p<sub>a</sub>: 4 mbar (0.4 kPa) to 20 mbar (2 kPa)</b> <b>MB-... S50/S52 p<sub>a</sub>: 4 mbar (0.4 kPa) to 50 mbar (5 kPa)</b>																					
Media	Gases of families 1, 2, 3 and other neutral gaseous media																					
Ambient temperature	-15 °C to +70 °C (Do not operate MB-D below 0 °C in liquid gas systems. Only suitable for gaseous liquid gas, liquid hydrocarbons destroy sealing materials.)																					
Dirt trap	Fine-mesh sieve. Replacement only possible by dismantling the fitting.																					
Pressure switches	Types GW...A5, ÜB...A2 / NB...A2 to DIN EN 1854 may be attached. For further information, refer to Datasheets 5.02 and 5.07 "Pressure Switches for DUNGS Multiple Actuators"																					
Pressure regulator	Pressure regulator compensated for residual pressure, leakproof seal when switched off by means of valve V1 as per DIN EN 88 Class A. Setpoint spring permanently installed (no spring exchange possible). A vent line above roof is not required. Internal pulse tap provided.																					
Solenoid valve V1	Valve as per DIN EN 161 Class A Group 2, fast closing, fast opening																					
Solenoid valve V2	Valve as per DIN EN 161 Class A Group 2, fast closing																					
	<table border="1"> <thead> <tr> <th></th> <th>Valve V2 design</th> <th>Partial volume restrictor</th> <th>Main volume restrictor</th> </tr> </thead> <tbody> <tr> <td>MB-ZR</td> <td>fast opening</td> <td>with</td> <td>without</td> </tr> <tr> <td>MB-ZRD</td> <td>fast opening</td> <td>with</td> <td>with</td> </tr> <tr> <td>MB-ZRDLE</td> <td>slow opening</td> <td>with</td> <td>with</td> </tr> <tr> <td>MB-ZRLE</td> <td>slow opening</td> <td>with</td> <td>without</td> </tr> </tbody> </table>			Valve V2 design	Partial volume restrictor	Main volume restrictor	MB-ZR	fast opening	with	without	MB-ZRD	fast opening	with	with	MB-ZRDLE	slow opening	with	with	MB-ZRLE	slow opening	with	without
	Valve V2 design	Partial volume restrictor	Main volume restrictor																			
MB-ZR	fast opening	with	without																			
MB-ZRD	fast opening	with	with																			
MB-ZRDLE	slow opening	with	with																			
MB-ZRLE	slow opening	with	without																			
Measuring / Ignition gas connection	For G 1/8 as per DIN ISO 228, refer to Pressure taps on page 2																					
Burner pressure monitor p <sub>Br</sub>	Connection downstream of valve V2, pressure switch A2 mountable on adapter laterally																					
Voltage / Frequency	50-60 Hz 220-230 V AC -15 % +10 % Other preferred voltages: 240 V AC, 110-120 V AC, 48 VDC, 24-28 VDC																					
Electrical connection	Plug connection as per DIN EN 175301-803 for valves and pressure switches																					
Rating / Power consumption Switch-on duration Degree of protection Radio interference	Refer to Dimensions on page 5 100 % IP 54 as per IEC 529 (EN 60529) Interference degree N																					
Materials of gas conveying parts	Housing Diaphragms, seals Solenoid drive	aluminium die casting NBR basis, Silopren (silicone rubber) steel, brass, aluminium																				
Installation position	Solenoid vertically upright or lying horizontally as well as its intermediate positions.																					
Closed position signal contact	Closed position signal contact, type K01/1 (DIN-tested), mountable on V2																					

Equipment variants GasMultiBloc®...B01 Two-stage function	405 B01	407 B01	410 B01	412 B01	
MB-ZR	•	•	•	•	
MB-ZRD	•	•	•	•	
MB-ZRDLE	•	•	•	•	
MB-ZRLE	•	•	•	•	
Microfilter with sieve	•	•	•	•	
Gas pressure switch downstream of filter	•	•	•	•	
downstream of valve V2 on adapter laterally	•	•	•	•	
Pressure regulator	•	•	•	•	
Valve V1, double seat	•	•	•	•	
Valve V2, single seat	•	–	•	–	
Valve V2, double seat	–	•	–	•	
Valves opening together	•	•	•	•	S 20, S 50
Valves opening separately	•	•	•	•	S 22, S 52
Flange Rp 1/2	•	•	–	–	• = possible (•) = on request - = not possible
Rp 3/4	•	•	•	•	
Rp 1	–	–	•	•	
Rp 1 1/4	–	–	•	•	

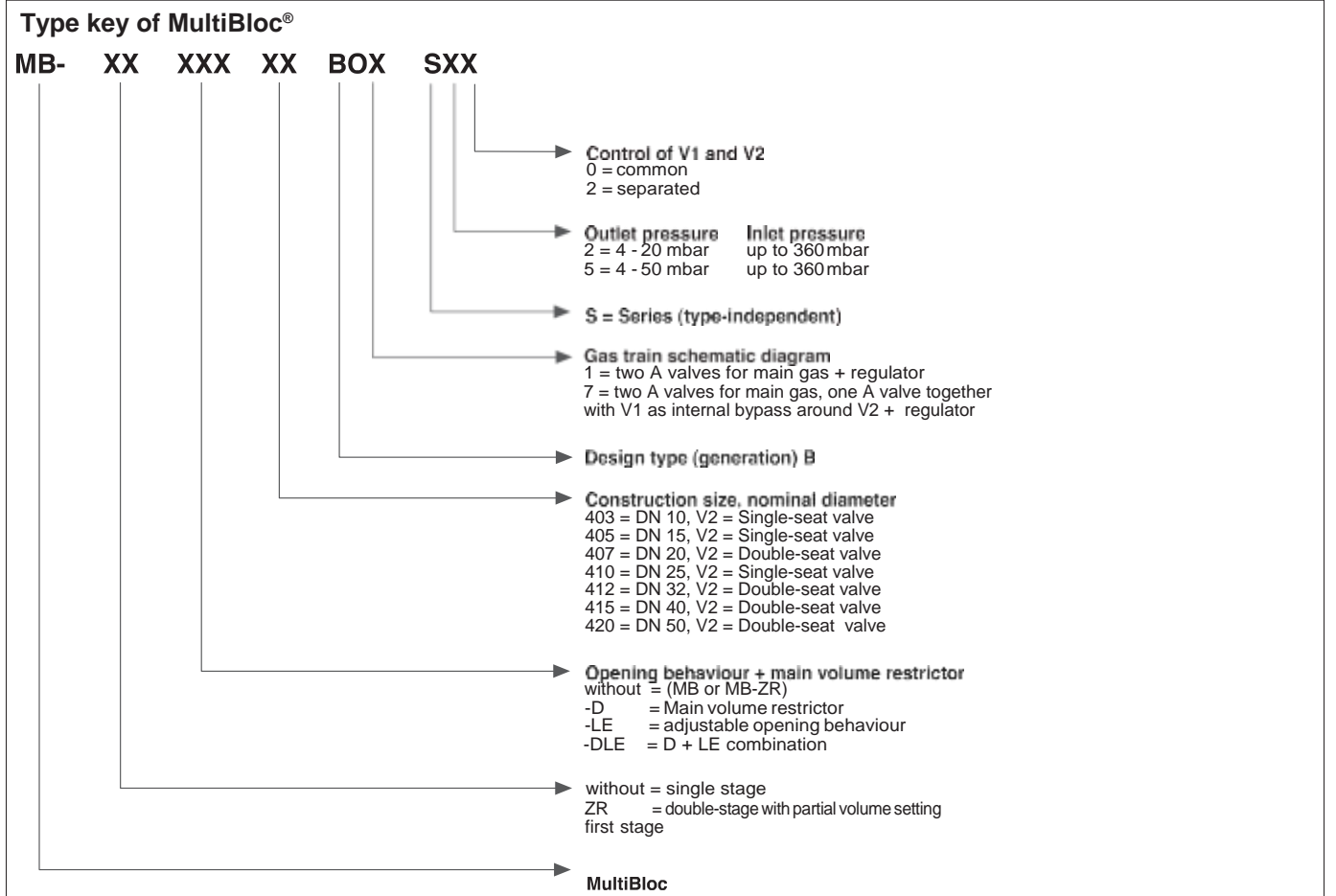
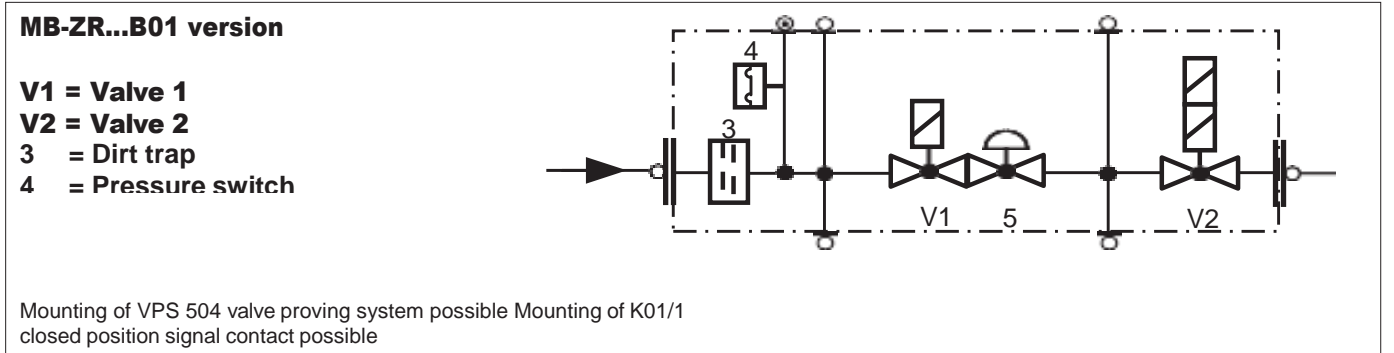

**Dimensions [mm]**

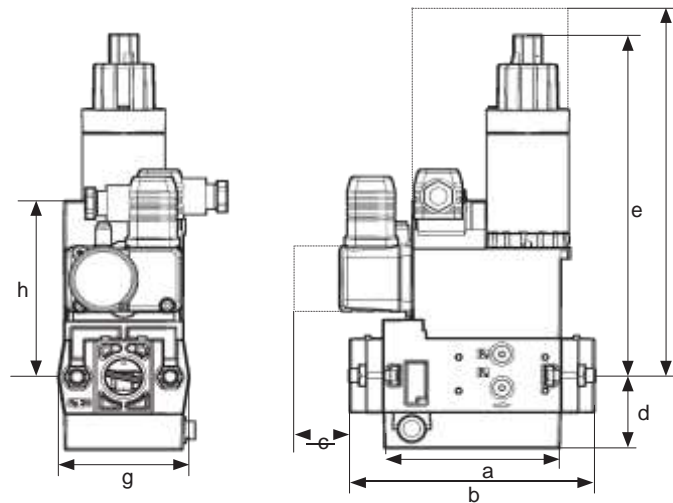

c = Space requirement for cover of pressure switch  
 f = Space requirement for exchanging the solenoid

Typ	Rp	Opening time	Dimensions [mm]								Weight [kg]
			a	b	c	d	e	f	g	h	
MB-ZRD 405 B.../407	Rp 1/2	< 1 s	110	151	40	46	180	250	74	115	3,3
ZRDLE 405 B.../407	Rp 3/4	< 20 s	110	151	40	46	220	250	74	115	3,4
410 B.../412	Rp 1	< 1 s	140	185	40	55	220	300	90	135	6,3
MB-ZRDLE 410 B.../412	Rp 1 1/4	< 20 s	140	185	40	55	260	300	90	135	6,4

**Electrical connection**

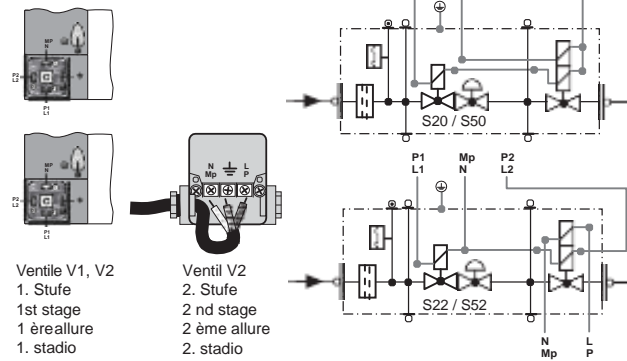

**Rating/power consumption**

[VA] ~(AC) 230 V; +20 °C:

MB 405/407 S 20	65
MB 405/407 S 50	65
MB 405/407 S 22	70
MB 405/407 S 52	70
MB 410/412 S 20	80
MB 410/412 S 50	80
MB 410/412 S 22	120
MB 410/412 S 52	120

**Pressure taps**

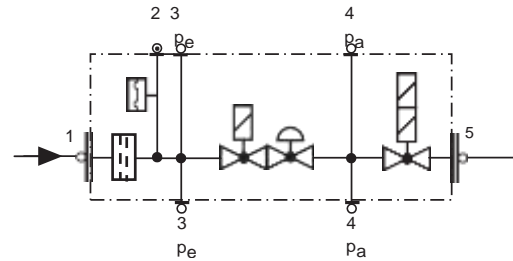
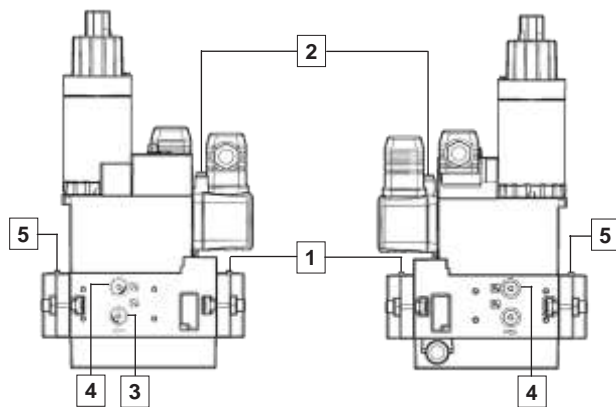

1, 3, 4, 5 G 1/8 screw plug  
 2 Test nipple

GasMultiBloc® Combined regulator and **safety shut-off valves**  
 Two-stage function

MB-ZRD(LE) 405 - 412 B01



**Volumetric flow pressure loss characteristics in regulated state with fine-mesh sieve**

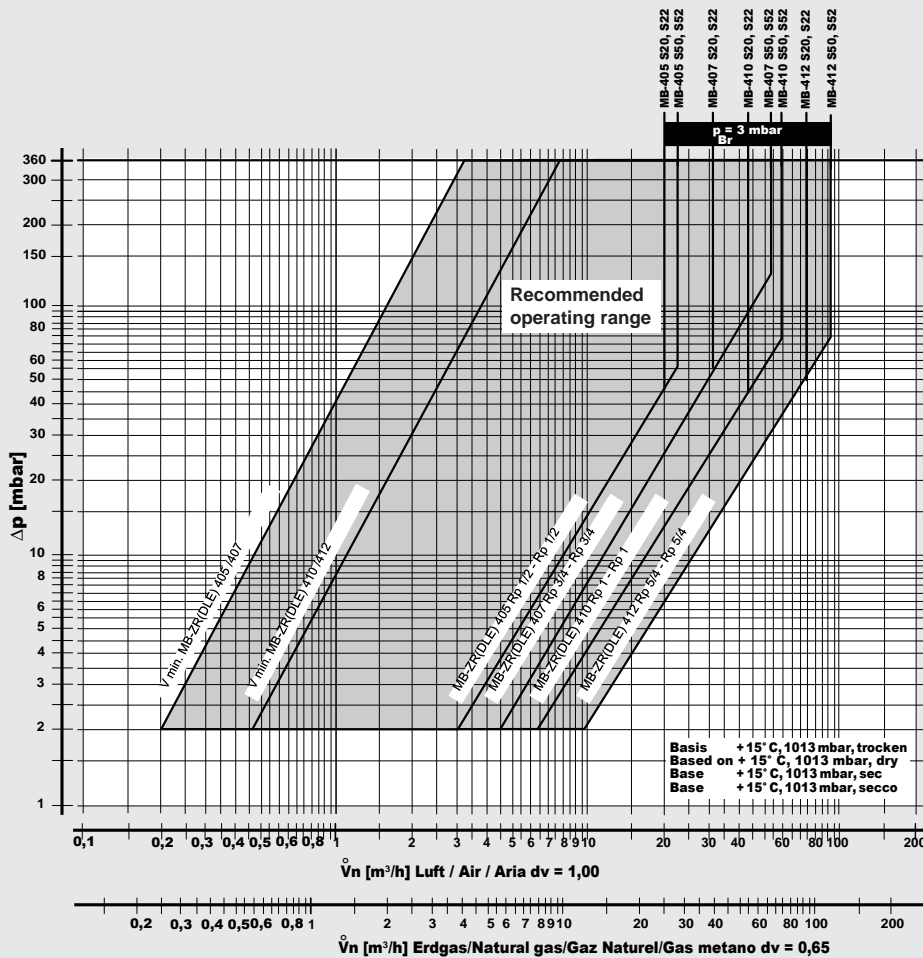

$f = \sqrt{\frac{\text{Dichte Luft}}{\text{Dichte des verwendeten Gases}}}$   
 Spec. weight air / Spec. weight of gas used  
 peso specifico aria / peso specifico del gas utilizzato  
 Dichte des verwendeten Gases / Spec. weight of gas used  
 poids spécifique du gaz utilisé / peso específico del gas utilizado

Gas type	Density	dv	f
Nat. gas	0.81	0.65	1.24
City gas	0.58	0.47	1.46
LPG	2.08	1.67	0.77
Air	1.24	1.00	1.00

$\dot{V}_{\text{verwendetes Gas/gas used/ gaz utilisé/gas utilizzato}} = \dot{V}_{\text{Luft/air/air/aria}} \times f$

We reserve the right to make any changes in the interest of technical progress.