



บริษัท เอดีดี เฟอร์เนส จำกัด

ADD FURNACE CO.,LTD.

44 ซอยบรมราชชนนี 70 ถนนบรมราชชนนี แขวงศาลาธรรมสพน์ เขตทวีวัฒนา กรุงเทพฯ 10170

โทร: 02-888-3472 โทร: ออกแบบ:08-08-170-170 แฟกซ์: 02-888-3258

<https://www.add-furnace.com> E-mail: sales@add-furnace.com

DUNGS®
Combustion Controls

Manual MPA 41xx PF

Edition: 04.18

GB





บริษัท เอดีดี เฟอร์เนส จำกัด

ADD FURNACE CO.,LTD.

44 ซอยบรมราชชนนี 70 ถนนบรมราชชนนี แขวงศาลาธรรมสพน์ เขตทวีวัฒนา กรุงเทพฯ 10170

โทร: 02-888-3472 โทร: ออกแบบ:08-08-170-170 แฟกซ์: 02-888-3258

https://www.add-furnace.com E-mail: sales@add-furnace.com



DUNGS®
Combustion Controls

EU-Konformitäts- erklärung Gebrauchs- anleitung	EU-Declaration of conformity Instructions	Déclaration de conformité EU Notice d'utilisation	Dichiarazione di conformità EU Istruzioni di esercizio e di montaggio
MPA 41xx PF			
Feuerungs- automat	Automatic Burner	Système de com- mande automatique des brûleurs	Sistema automa- tico per bruciatori



MPA 41xx PF
257 539



บริษัท เอดีดี เฟอร์เนส จำกัด

ADD FURNACE CO.,LTD.

44 ซอยบรมราชชนนี 70 ถนนบรมราชชนนี แขวงศาลาธรรมสพน์ เขตทวีวัฒนา กรุงเทพฯ 10170

โทร: 02-888-3472 โทร: ออกแบบ:08-08-170-170 แฟกซ์: 02-888-3258

https://www.add-furnace.com E-mail: sales@add-furnace.com**DUNGS®**
Combustion Controls**EU-Konformitäts-
erklärung****EU Declaration of
conformity****Déclaration de
conformité EU****Dichiarazione di
conformità EU**

Produkt / Product Produit / Prodotto	MPA 41xx PF		Feuerungsautomat Automatic Burner Système de commande automatique des brûleurs Sistema automatico per bruciatori
Hersteller / Manufacturer Fabricant / Produttore	Karl Dungs GmbH & Co. KG Karl-Dungs-Platz 1 D-73660 Urbach, Germany		
bescheinigt hiermit, dass die in dieser Übersicht genannten Produkte einer EU-Baumusterprüfung unterzogen wurden und die wesentlichen Sicherheitsanforderungen der:	certifies herewith that the products named in this overview were subjected to an EU Prototype Test and meet the essential safety requirements:	certifie par la présente que le produit mentionné dans cette vue d'ensemble a été soumis à un examen de type de l'UE et qu'il est conforme aux exigences en matières de sécurité des dernières versions en vigueur de :	Con la presente si certifica che i prodotti citati in questa panoramica sono stati sottoposti a una prova di omologazione UE e che i requisiti di sicurezza essenziali:
EU-Gasgeräteverordnung 2016/426	EU Gas Appliances Regulation 2016/426	l'ordonnance de l'UE relative aux appareils au gaz 2016/426	regolamento UE sugli apparecchi a gas 2016/426
EU-Druckgeräterichtlinie 2014/68	EU Pressure Equipment Directive 2014/68	à la directive UE « Équipements sous pression » 2014/68	direttiva UE sulle attrezzature a pressione 2014/68
in der gültigen Fassung erfüllen. Bei einer von uns nicht freigegebenen Änderung des Gerätes verliert diese Erklärung ihre Gültigkeit.	as amended. In the event of an alteration of the equipment not approved by us this declaration loses its validity.	Ce communiqué n'est plus valable si nous effectuons une modification libre de l'appareil.	sono soddisfatti nella versione valida. In caso di modifica dell'apparecchio non ammessa, questa dichiarazione perde di validità.
Prüfgrundlage der EU-Baumusterprüfung Specified requirements of the EU Prototype Test Base d'essai de l'examen de type de l'UE	EN 298 EN 13611 EN 61508		
Criteri di prova dell'omologazione UE			
Gültigkeitsdauer/Bescheinigung Term of validity/attestation Validité/certificat	2021-05-22	2028-04-08	
Durata della validità/Attestazione	CE0036	CE-0123CT1090	
Notifizierte Stelle Notified Body Organisme notifié Organismo notificato	2014/68/EU TÜV SÜD Industrie Service GmbH Westendstraße 199 D-80686 München Germany Notified Body number: 0036	(EU) 2016/426 TÜV SÜD Product Service GmbH Zertifizierstellen Ridlerstraße 65 D-80339 München Germany Notified Body number: 0123	
Überwachung des QS-Systems Monitoring of the QA system Contrôle du système d'assurance qualité Monitoraggio del sistema QS	Gewähltes Konformitätsverfahren Modul B+D Conformity process adopted: Module B+D Procédure de conformité sélectionnée : module B+D Procedura di conformità selezionata: modulo B+D		

Dr.-Ing. Karl-Günther Dalsäß,
Geschäftsführer / Chief Operating Officer
Directeur / Amministratore
Urbach, 2018-04-21



บริษัท เอดีดี เฟอร์เนส จำกัด

ADD FURNACE CO.,LTD.

44 ซอยบรมราชชนนี 70 ถนนบรมราชชนนี แขวงศาลาธรรมสพน์ เขตทวีวัฒนา กรุงเทพฯ 10170

โทร: 02-888-3472 โทร: ออกแบบ:08-08-170-170 แฟกซ์: 02-888-3258

https://www.add-furnace.com E-mail: sales@add-furnace.com



Product Service

EU-Type Examination Certificate

No. C5A 18 04 22629 014

Holder of Certificate: Karl Dungs GmbH & Co. KG

Karl-Dungs-Platz 1
73660 Urbach
GERMANY

Product: Fittings (Gas)
Burner control system

Model(s): MPA 41xx

Parameters: Valid from 2018-04-21
PIN CE-0123CT1090

for further information see annex

Tested according to: DIN EN 298:2012
DIN EN 13611:2011
DIN EN 61508-1:2011
DIN EN 61508-2:2011
DIN EN 61508-3:2011

The Certification Body of TÜV SÜD Product Service GmbH confirms according to Annex III (Module B) that the listed product complies with the relevant provisions according to Annex I of Regulation (EU) 2016/426 on appliances burning gaseous fuels. It refers only to the sample submitted for testing and certification and on its technical documentation. See also notes overleaf.

Printed in Germany • Edition 04.18 • Nr. 271 958

Test report no.: C-F 1426-07/18

Valid until: 2028-04-08



Date, 2018-04-09

(Norbert Hörmann)

TÜV SÜD Product Service GmbH is Notified Body according to Regulation (EU) 2016/426 on appliances burning gaseous fuels with identification No. 0123.

Page 1 of 3



บริษัท เอดีดี เฟอร์เนส จำกัด

ADD FURNACE CO.,LTD.

44 ซอยบรมราชชนนี 70 ถนนบรมราชชนนี แขวงศาลาธรรมสพน์ เขตทวีวัฒนา กรุงเทพฯ 10170

โทร: 02-888-3472 โทร: ออกแบบ:08-08-170-170 แฟกซ์: 02-888-3258

https://www.add-furnace.com E-mail: sales@add-furnace.com



Product Service

ZERTIFIKAT ◆ CERTIFICATE ◆ CERTIFICADO ◆ CERTIFICAT ◆ СЕРТИФИКАТ ◆ 認證證書

EU-Baumusterprüfbescheinigung

Nr. C5A 18 04 22629 014

Zertifikatsinhaber: Karl Dungs GmbH & Co. KG

Karl-Dungs-Platz 1
73660 Urbach
DEUTSCHLAND

Produkt: Ausrüstungen (Gas)
Feuerungsautomat

Modell(e): MPA 41xx

Kenndaten: Gültig ab 21.04.2018
PIN CE-0123CT1090

alle weiteren Kenndaten siehe Anhang

Geprüft nach: DIN EN 298:2012
DIN EN 13611:2011
DIN EN 61508-1:2011
DIN EN 61508-2:2011
DIN EN 61508-3:2011

Die Zertifizierstelle von TÜV SÜD Product Service GmbH bestätigt gemäß Anhang III (Modul B) die Übereinstimmung des bezeichneten Produktes mit den wesentlichen Anforderungen gemäß Anhang I der Verordnung (EU) 2016/426 über Geräte zur Verbrennung gasförmiger Brennstoffe. Prüfgrundlage ist ausschließlich das zur Prüfung und Zertifizierung vorgestellte Prüfmuster sowie dessen technische Dokumentation. Umseitige Hinweise sind zu beachten.

Prüfbericht Nr.: C-F 1426-07/18

Gültig bis: 2028-04-08



Datum, 2018-04-09 (Norbert Hörmann)

TÜV SÜD Product Service GmbH ist notifizierte Stelle gemäß der Verordnung (EU) 2016/426 über Geräte zur Verbrennung gasförmiger Brennstoffe mit der Kennnummer 0123.

Seite 1 von 3



Table of contents

Target group/warnings	7-8
Data sheet	9-12
Approval overview	13
System description/Variants/Accessories	14
General technical data	15
Connection diagram	16
Technical data outputs/inputs	17-19
Flame detection/Flame detector connection	20
Installation/Dimensions MPA 412x	21-23
Description of the functions	
Unlocking function	
Extended unlocking	
Access level	24
Description of the functions	
Gas valves	
Flame detector	
Air pressure switch	
HT signal, gas pressure switch or proof-of-closure contact	
Parameterisation mode (manual operation)	
Automatic/Parameterisation mode function switch	25
Flow Chart	26-27
Description of the states	28-31
Parameters/Parameter change	32
Parameters/Parameter description	33-41
Parameters/Factory setting	42-43
Status information	44-45
MPA 41x2/Version with display	46
MPA 41x2/Overview of the display modes	47
MPA 41x2/On-screen display	48
MPA 41x2/Operation display	49
MPA 41x2/Operation display additional information	50
MPA 41x2/Operation display parameterisation and service box	51
MPA 41x2/Info display	52
MPA 41x2/Error display	53
MPA 41x2/Error memory display	54
MPA 41x2/Parameterisation display	55-61
MPA 41x2/Reset display	62-63
MPA 41xx errors without error ID	64
MPA 41xx errors from the basic system	65-66
MPA 41xx errors from the extension system	67
Errors from the application	68
Annex	69
Setting the bus address, bus termination	70-71
Profibus	72-76
Modbus	77-84
Profibus/Modbus Line lengths, baud rates, bus termination, pin assignment	85
Flame detector	86-87
UV 41 (HE)	88-89
Ignition transformers	90-92
VisionBox	93



Instruction manual

MPA 41xx PF

1. Target group

The target group of this manual is **qualified personnel of the gas safety and regulating technology, skilled personnel or the persons instructed by them.**

Due to their specialist training, knowledge and experience and knowledge of standard regulations, they are capable of evaluating the work assigned to them and recognising possible dangers. Only they are permitted to carry out as-sembly, commissioning, settings and maintenance on the devices in compliance with the recognised rules for occupa-tional safety.



Hang this instruction manual in a readily visible place inside the installation room! Do not carry out any work until you have read the safety instructions of this instruction manual.

2. Warnings

2.1 General warnings



The recognised occupational safety rules and accident prevention regulations must be observed and, if necessary, personal protective measures must be taken.



All adjustments and settings should only be performed in accordance with the instruction manuals of the connect-ed machines.



Never carry out work as long as gas pressure or voltage is applied. Avoid open fire. Please observe public regula-tions.



Prior to assembly, the device must be inspected for transport damage.



The device must not be exposed to open fire. Protection against lightning strikes must be guaranteed.



from dirt and contamination. Connected line systems must be free



Protection from environmental impacts and weather conditions (corrosion, rain, snow, icing, humidity (e.g. by conden-sation), mould, UV radiation, harmful insects, poisonous, corrosive solutions/ liquids (e.g. cutting and cooling fluids), must be guaranteed. Depending on the installation site, it may be necessary to take protective measures.



The device may only be operated in compliance with the operating condi-tions stated on the type plate.



The device must be protected from vibrations and mechanical impacts.



The device must not be used in areas with increased seismic risk.

Explanation of the symbols

- 1, 2, 3,... = Order of action
- = Instruction



2.2 Designated use

The device is used in accordance with its designated use if the following instructions are observed:

- Use only in compliance with the operating conditions stated on the type plate.
- Use in perfect condition only.

- Malfunctions and faults must be eliminated immediately.
- Use only in observance of the instructions given in this instruction manual and of national regulations.

2.3 Risks in case of misuse

- If used in accordance with their designated use, the devices are safe to operate.
- Non-observance of the regulations may result in personal injury or material damage, financial damage or environmental damage.

- Operator errors or misuse present risks to life and limb of the operators and also to the device and other material property.



บริษัท เอดีดี เฟอร์เนส จำกัด

ADD FURNACE CO.,LTD.

44 ซอยบรมราชชนนี 70 ถนนบรมราชชนนี แขวงศาลาธรรมสพน์ เขตทวีวัฒนา กรุงเทพฯ 10170

โทร: 02-888-3472 โทร: ออกแบบ:08-08-170-170 แฟกซ์: 02-888-3258

<https://www.add-furnace.com> E-mail: sales@add-furnace.com

µP Automatic burner control system MPA 41xx PF

Automatic burner control system for
high-speed burners with fast On/Off
switching (pulse firing)

DUNGS[®]
Combustion Controls

neuinovità
nouveaunew

- Automatic burner control system for pulse firing applications
- Fast On/Off switching
- High number of switching cycles possible
- High temperature operation possible
- Configurable



Description

Microprocessor-controlled automatic burner control system for the intermittent operation of high-speed burners with fast On/Off switching (pulse firing).

The program sequence and times can be customised by setting software parameters.

Versions

- MPA 4112 PF with integrated display
- MPA 4122 PF with metal

housing and integrated display

Application

For high-speed burners with fast On/Off switching (pulse firing). In particular for industrial thermoprocessing equipment to EN 746-2.

Approvals

EC type-examination certificate according to the EC gas appliances directive:

MPA 41xx CE-0085BU 0487

EC type-examination certificate according to the EC Pressure Equipment Directive:

MPA 41xx CE0036

Suitable for applications up to SIL 3. Meets the requirement according to IEC 61508 (2nd Ed. 2011) Certified by TÜV Süd

CSA certified product according to CSA 22.2 (MPA 4112 PF)

UL Recognized Component per UL 372, UL 1998 (MPA 4112 PF).



The MPA 41xx PF is suitable for use with high-speed burners with fast On/Off switching (pulse firing). Flame monitoring is carried out by means of an ionisation input.

- MPA 41xx PF can be configured via display without laptop/PC
- High temperature operation can be activated using an external switching signal
- Extension module for Profibus and Modbus communication
- Air purge function (via bus)

Connection diagram MPA 4112 PF

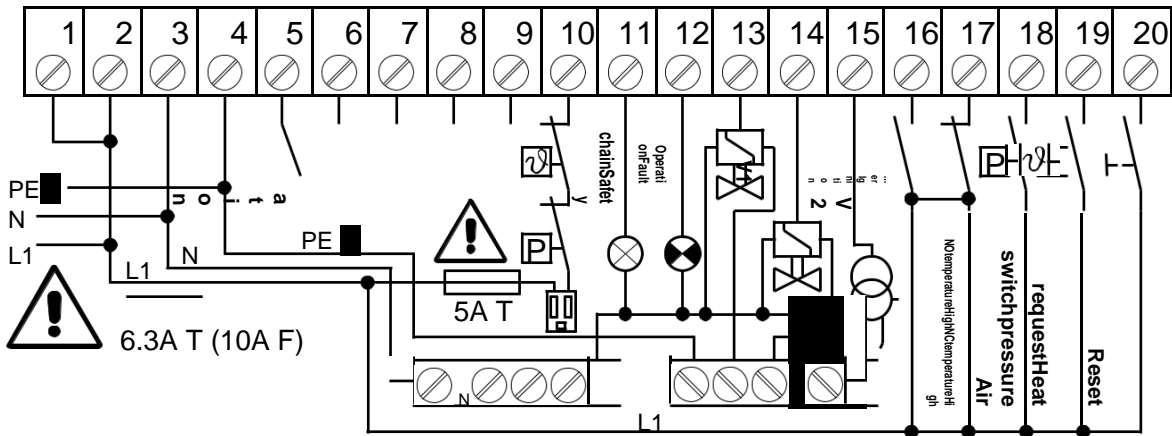

* The connection cables used must be suitable for an ambient temperature of at least 75 °C (167 °F).

Connection diagram MPA 4122 PF

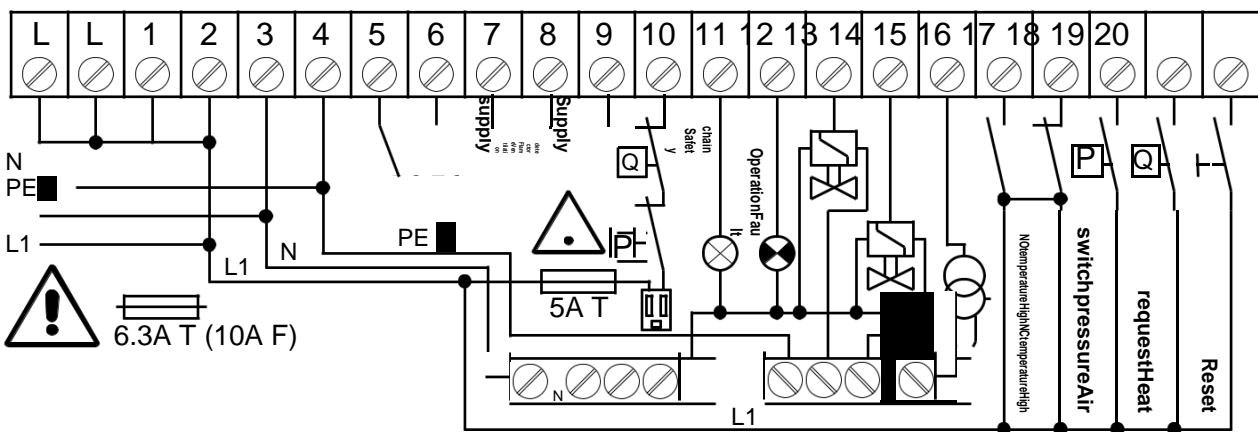

* The connection cables used must be suitable for an ambient temperature of at least 75 °C (167 °F).



The program sequence and times can be modified on the mounted display to match each application.

A laptop or PC is not required for the modification.

The automatic systems are protected by passwords against unauthorised access. All settings for the MPA 41xx PF auto-matic burner control system can also be made by means of a laptop/PC via MPA Vision Box.



Display modes

Operation display

- Display of the current operating state
- Display of the program state
- Display of bus address

Info display

- Display of flame quality
- Display of resettable counters for start-up, operating hours and switching cycles

Error display

Display of the error memory

- Automatic activation of error messages
- Additional information about faults
- Query of the ten last errors

Parameterisation display

- Password-protected functional levels for service and OEM parameter settings
- Setting important parameters such as: **Pre-venting time**
Safety time for start-up
Post-venting time
Behaviour after flame failure

Communication

MPA 41xx extension module EM2/4 Additional circuit board and connector set for Profibus DP and Modbus communication.

Parameter setting and service MPA 41xx parameterisation and service box

Universal support for device checking in the field; for producing small and medium series.

MPA Vision Box

As addition to MPA41xx parameterisation and service box for setting parameters via a PC/laptop.

Accessories

UV 41 (HE)

UV flame detector for high mechanical load; metallic version. Suitable for intermittent operation.

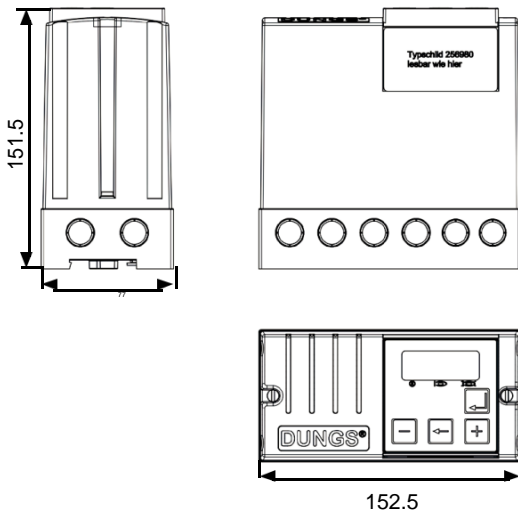
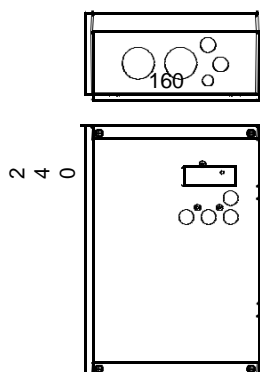

**µP-Automatic burner control system
MPA 41xx PF****Automatic burner control system for
one-stage and modulating gas burn-
ers****DUNGS®**
Combustion Controls**Dimensions [mm]****MPA 4112 PF****MPA 4122 PF****Technical data**

Rated voltage	115 VAC -15 % ... +10 %
(depending on the model)	230 VAC -15 % ... +10 %
Frequency	50 Hz...60 Hz
Power consumption	max. 10 VA
Fuse	max. 6.3 A slow-blow or 10 A fast-blow max. 1 A
Operating signal	max. 1 A
Interfering signal	max. 1 A
Gas valves	max. 2 A
Fan	max. 1 A
Ignition	max. 1 A
Flame detector supply	230 VAC / 10 mA
Flame detector ionisation	10 - 20 µA
ionisation current/operation	1.2 µA
Shutdown sensitivity	approx. 280 µA
Short circuit current limiting	Pushbuttons and remote unlocking
Unlocking due to fault	MPA 4112 / IP 54
Protection type	MPA 4122 / IP 65
Ambient temperature	-40 °C - +70 °C
	-20 °C - +60 °C (UL approval)

Ordering data

MPA 4112 PF/230 VAC	Article no. 270 520
MPA 4112 PF/115 VAC	Article no. 270 528
MPA 4122 PF/230 VAC	Article no. 273 323
MPA 4122 PF/115 VAC	Article no. 273 324

Extension module on request

EM2/4 MPA 41x

Profibus DP,

Modbus

Flame detector

UV 41







Article no. 256 692

UV 41 HE

Article no. 260 575



Overview of approvals

Overview of approvals	Article number	CE 	FM 	UL recognized 	UL listed 	CSA C22.2 	EAC 	AGA 
MPA 4112 PF / AC 230 V	270520	x				x	x	x
MPA 4112 PF / AC 115 V	270528	x		x		x	x	x
MPA 4122 PF / AC 230 V	273323	x						
MPA 4122 PF / AC 115 V	273324	x						
Extension module								
EM2/4 MPA 411x	257960	x	x	x		x	x	(x)*
EM2/4 MPA 412x	257961	x						
Flame detector								
UV41	256692	x	x	x		x	x	x
UV41 HE	260575	x	x	x		x	x	(x)*
Ignition transformers								
DEZ 1xx	all	x		(x)*			x	
DEZ 2xx	all	x		(x)*			x	

* on request

Safety Integrity Level (SIL)

MPA41xx PF	UV41 (HE)	Components	SIL	SFF	PFH
X		Ionisation input	3	99.48 %	1,80E-09
X		Input HT	3	99.39 %	1,80E-09
X	X	UV41 + ionisation input	2	96.91 %	1,50E-07



1 MPA 41xx PF system description

The MPA 41xx PF is suitable for use with high-speed burners with fast On/Off switching (pulse firing).

Flame monitoring is carried out by means of an ionisation input. High temperature operation can be activated using an external switching signal.

The MPA 41xx parameterisation and service box is available for the production of small series and for checking the system when service is required.

For operation in burner networks, a Profibus/Modbus communication over the extension module EM2/4 is possible.

System variants

Designation	Article no.	Voltage	Display
MPA 4112 PF	270520	230 VAC	3-digit 7-segment display
MPA 4112 PF	270528	115 VAC	3-digit 7-segment display
MPA 4122 PF	273323	230 VAC	3-digit 7-segment display
MPA 4122 PF	273324	115 VAC	3-digit 7-segment display

Accessories

Ignition transformers:

- DEZ xxx
- Mains connection line
- Ignition line

Flame detector:

- UV: UV 41, UV 41 HE

Extension module EM

- EM 2/4: Profibus DP, Modbus



Technical data

General MPA 41xx PF	
Protection type	
MPA 4112 PF	IP 54 / NEMA 12
Schutzart Metallgehäuse	
MPA 4122 PF	IP 65 (Attention: use suitable cable screw connections only!)
Ambient temperature	-40 °C ... +70 °C
MPA 41xx PF	
Storage and transport	-40 °C ... +80 °C
Humidity	DIN 60730-1, no dewing admissible
Altitude	Suitable for use up to 2000 m above the base height level
Lifetime	At least 2.5 million switching operations depending on the contact load
Switching outputs	
Mounting position	as desired
Dimensions	MPA 4112 (L x H x D): approx. 152.5 x 151.5 x 77 mm
MPA 4112 PF	
in mm	
Dimensions	MPA 4122 (L x H x D): approx. 160 x 240 x 80 mm
MPA 4122 PF	(excluding cable screw connection)
in mm	
Weight MPA 4112 PF	0,82 kg
Weight MPA 4122 PF	2,2 kg

Electrical data	
Rated voltage	230 VAC -15 % ... +10 % or 115 VAC -15 % ... +10 %, depending on the version
Frequency	50 Hz / 60 Hz
Fuse	6.3 A slow-blow or 10 A fast-blow, integrated, 5 A slow-blow in the fuse holder, replaceable
Isolation	No galvanic isolation between mains and 24 VDC or 5 VDC
Electrical connection	Correct (!) phase connection and protective earth conductor according to the wiring diagram The contact protection for the UV sensor must be guaranteed by mounting it in the operating equipment
Power consumption (own consumption)	Maximum 10 W Typically 115 V 230 V Standby 2.7 W 3.6 W Operation 3.4 W 6.1 W With extension card EM2/4: Standby 4.0 W ... 4.7 W Operation 4.6 W ... 7.4 W
Short-circuit current ION against N	280 µA



Connection diagram
MPA 4112 PF

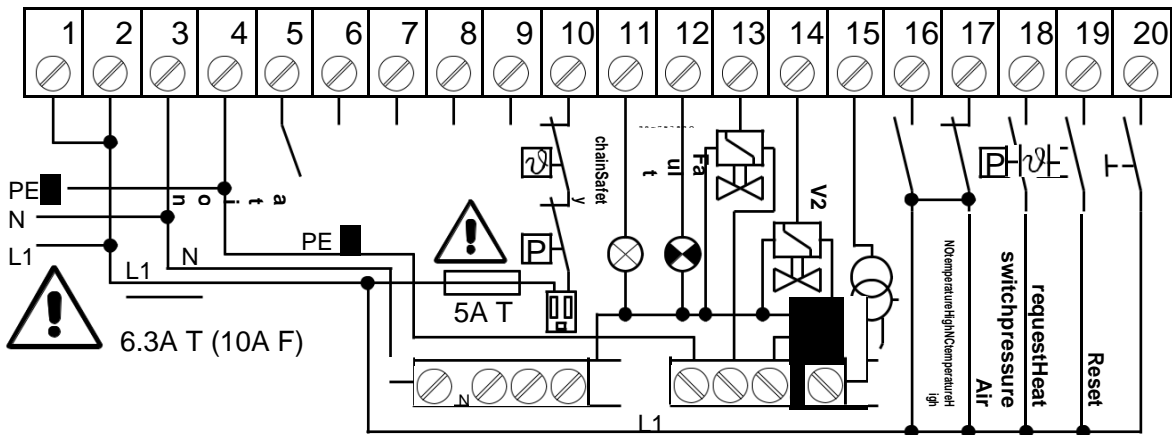

* The connection cables used must be suitable for an ambient temperature of at least 75 °C (167 °F)

Connection diagram MPA 4122 PF

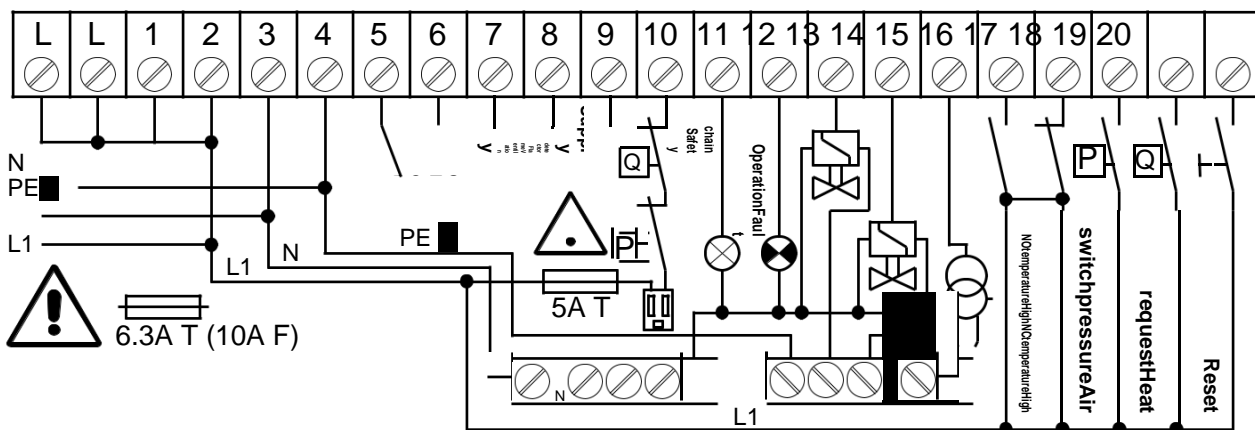

* The connection cables used must be suitable for an ambient temperature of at least 75 °C (167 °F).

Attention:

After having removed the hood, you might get in contact with the electrical connections in the terminal socket. Risk of fatal electric shocks! Therefore, you must interrupt the power supply before removing the hood.

Do not remove the jumper between terminals 1 and 2, which was mounted in the factory. It is required for the intended use of the automatic burner control system.

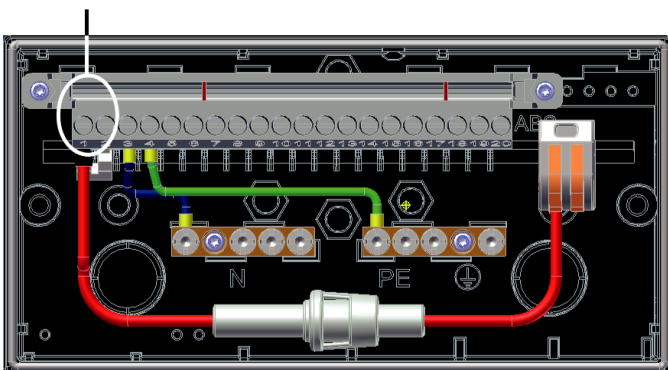



Technical data

Outputs					
Designation	Connec- tion X	Safety- related	Type of output	Line length	Electrical data
V1 Safety valve	13	x	Relay contact	Max. 100 m	For 250000 switching cycles: 115/230 VAC / 2 A $\cos \phi = 1$ For 2.5 million switching cycles: 115/230 VAC / 1 A $\cos \phi = 1$ Minimum load 0.5 W
V2 configurable	14	x	Relay contact	Max. 100 m	For 250000 switching cycles: 115/230 VAC / 2 A $\cos \phi = 1$ For 2.5 million switching cycles: 115/230 VAC / 1 A $\cos \phi = 1$ Minimum load 0.5 W
Ignition	15	x	Relay contact	Max. 100 m	For 250000 switching cycles: 115/230 VAC / 1 A $\cos \phi = 0,4$ corresp. 115/230 VAC / 2.5 A $\cos \phi = 1$ For 2.5 million switching cycles: 115/230 VAC / 1 A $\cos \phi = 1$ Minimum load 0.5 W
Ventilation	8	-	Relay contact	Max. 100 m	For 250000 switching cycles: 115/230 VAC / 1 A $\cos \phi = 0,4$ corresp. 115/230 VAC / 2.5 A $\cos \phi = 1$ For 2.5 million switching cycles: 115/230 VAC / 1 A $\cos \phi = 1$
HT function or AUX out Multifunction out- put configurable	11	-	Relay contact	Max. 100 m	115/230 VAC / 1 A $\cos \phi = 1$
Fault Alarm	12	-	Relay contact	Max. 100 m	115/230 VAC / 1 A $\cos \phi = 1$
FLW power	7	-	For UV41 (HE)	Max. 100 m	230 VAC / 10 mA *1

*1: The flame detector is always supplied with 230 VAC, even the 115 VAC version, via the "Flame detector supply" connection 7.

The sum of the currents of all safety-related consumers must not exceed 5 A (observe the value of the fuse) The sum of the currents of all consumers must not exceed 6.3 A (10 A).



บริษัท เอดีดี เฟอร์เนส จำกัด

ADD FURNACE CO.,LTD.

44 ซอยบรมราชชนนี 70 ถนนบรมราชชนนี แขวงศาลาธรรมสพน์ เขตทวีวัฒนา กรุงเทพฯ 10170

โทร: 02-888-3472 โทร: ออกแบบ:08-08-170-170 แฟกซ์: 02-888-3258

<https://www.add-furnace.com> E-mail: sales@add-furnace.com

Inputs					
Designation	Connec-tion X	Safety-related	Type of output	Line length	Electrical data
L1	1		Contact		
N	3		Contact		
PE/Earth	4		Contact		
Input safety chain (from L1, se-cured via fuse in fuse holder)	10	x	Contact	Max. 100 m	115/230 VAC / max. 5 A
Flame detector Ionisation*1	5	x	Ionisation for one or two-probe operation	Max. 10 m*2	Threshold value: approx. 1.2 µA
Temperature signal NO	16	x	Switching contact	Max. 100 m	115/230 VAC "normally open"
Temperature signal NC or Proof of closure or gas pressure switch min.	17	x	Switching contact	Max. 100 m	115/230 VAC "normally closed"
Heat request	19		Switching contact	Max. 100m	115/230 VAC
Air pressure switch	18	X	Switching contact	Max. 100m	115/230 VAC
Remote unlock-ing*3	20		Switching contact	Max. 100m	115/230 VAC

*1 Safety-relevant in the flame operation, not safety-relevant in the HT mode (flame detection off).

*2 For special applications, ionisation cable lengths of up to 50m are possible upon request.

*3 The Remote unlock function is safety-relevant.



บริษัท เอดีดี เฟอร์เนส จำกัด

ADD FURNACE CO.,LTD.

44 ซอยบรมราชชนนี 70 ถนนบรมราชชนนี แขวงศาลาธรรมสพน์ เขตทวีวัฒนา กรุงเทพฯ 10170

โทร: 02-888-3472 โทร: ออกแบบ:08-08-170-170 แฟกซ์: 02-888-3258

<https://www.add-furnace.com> E-mail: sales@add-furnace.com

Technical data

General information		
Designation	Type of input	Electrical data
L1 connection over exchangeable backup fuse		6.3 A slow-blow or 10 A fast-blow
Safety chain connection via exchangeable backup fuse in the fuse holder		5 A slow-blow
TWI interface	TWI	Connection only for VisionBox and parameter setting box NOT galvanically isolated!
Switch for parameterisation mode	Bistable switch	Selector switch inside the MPA (may only be switched after having removed MPA from the base)
"Display" unit	Inside the housing for integrated display	3x7 segment + 4 keys

Spark generator connection

The MPA 41xx PF does not have a built-in ignition transformer.

For suitable ignition transformers,

see accessory list.

Attention: A special spark generator is required depending on the electrode arrangement (e.g. operation with one electrode)



Flame monitoring and ignition
Flame detector connection

One-electrode operation ionisation

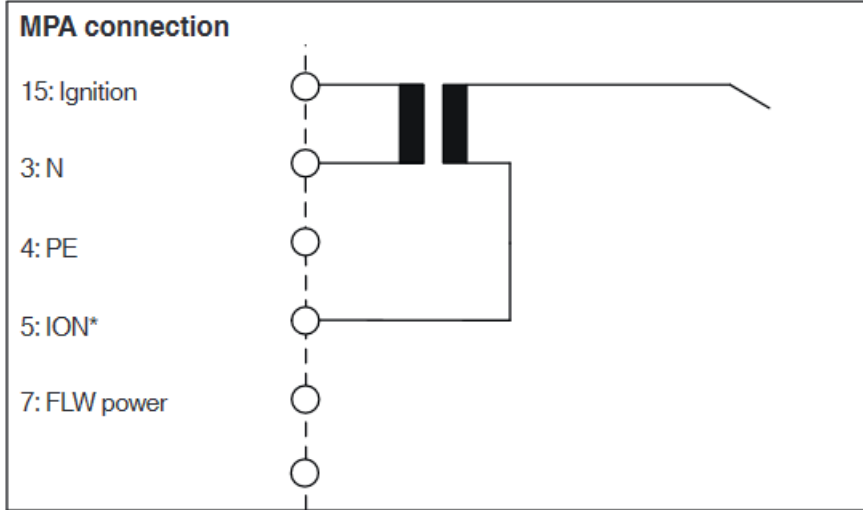

*When using a DUNGS DEZ 1xx SEO ignition transformer for single-electrode operation, the green/yellow cable must be connected to terminal 5.

Two-electrode operation ionisation

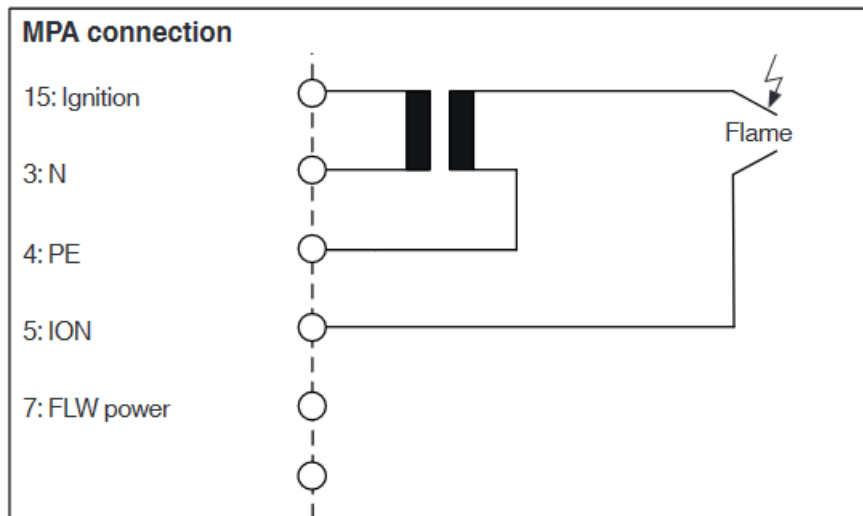

Flame detector UV41 (HE)

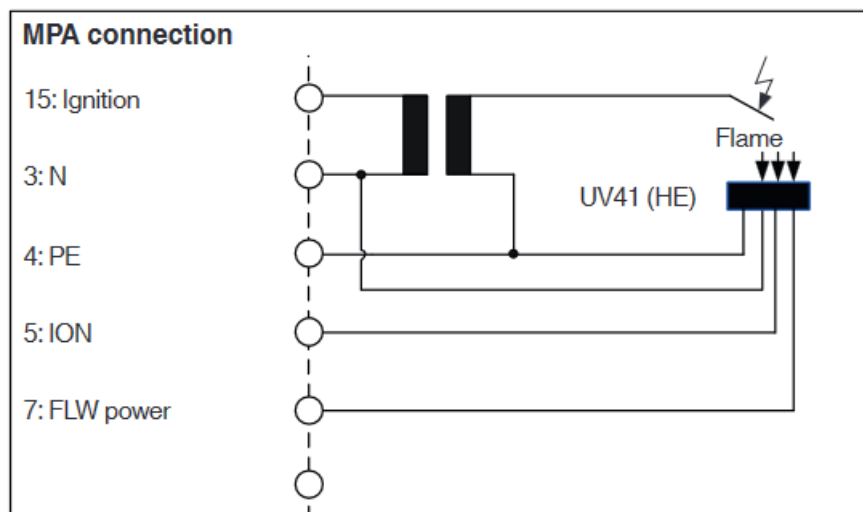



MPA 41xx PF installation

MPA 4112 PF installation options:

- Direct screw connection of the base to the installation surface
Break off installation holes using, for example, a suitable screwdriver or bore them using a drill 4.2 mm (M4) or 5.5 mm (M5).
- Hat rail mounting (locking the base into place on a hat rail)

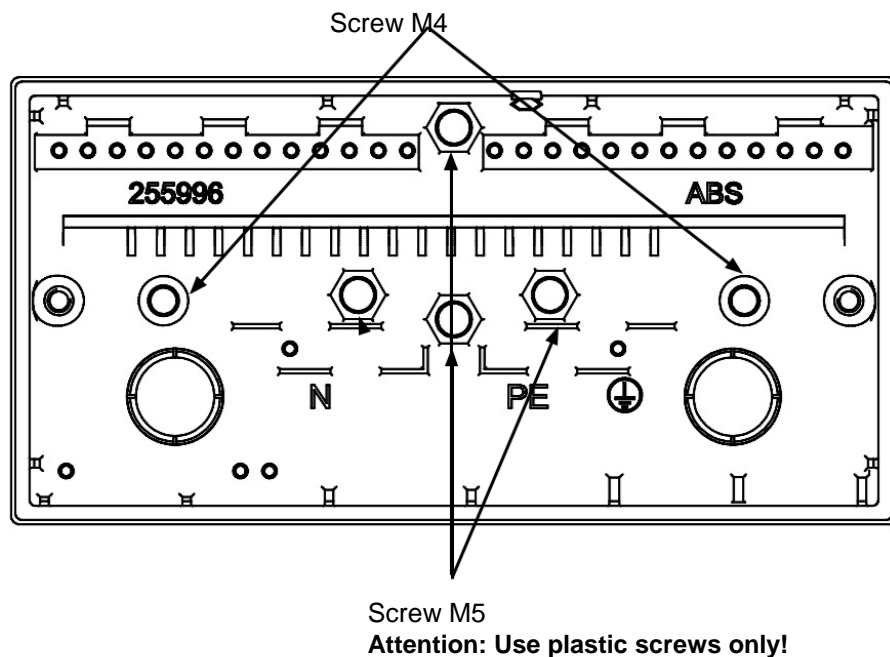
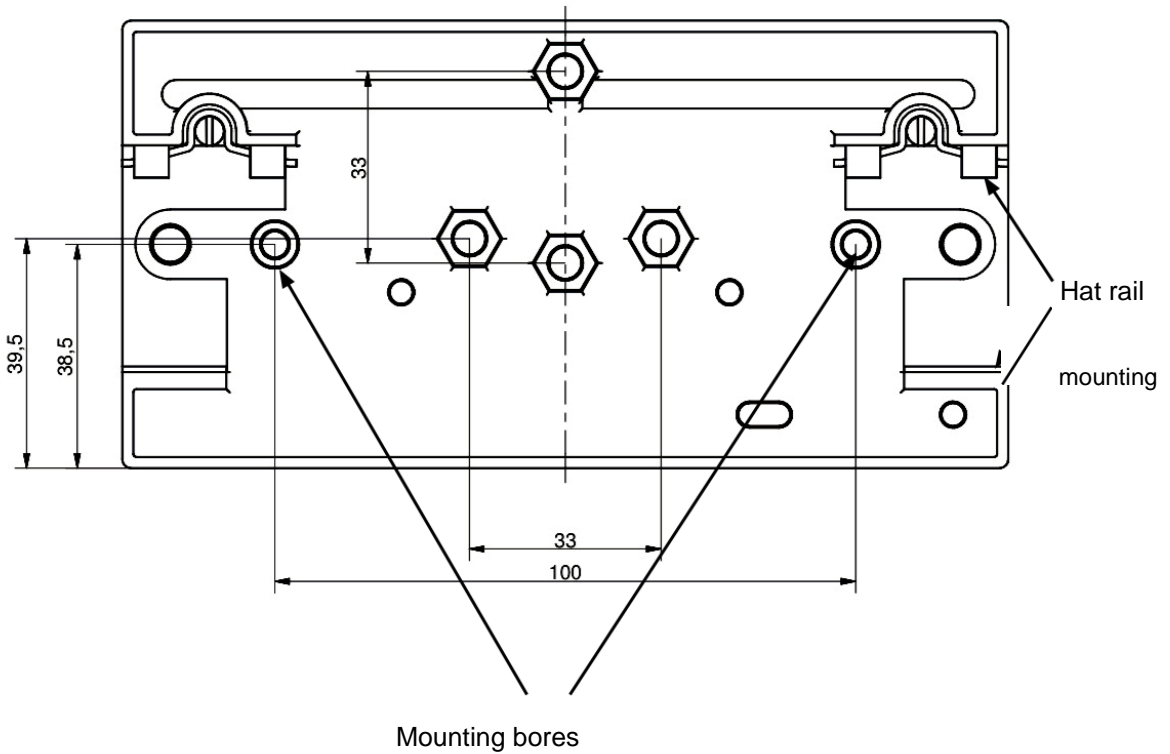



บริษัท เอดีดี เฟอร์เนส จำกัด

ADD FURNACE CO.,LTD.

44 ซอยบรมราชชนนี 70 ถนนบรมราชชนนี แขวงศาลาธรรมสพน์ เขตทวีวัฒนา กรุงเทพฯ 10170

โทร: 02-888-3472 โทร: ออกแบบ:08-08-170-170 แฟกซ์: 02-888-3258

<https://www.add-furnace.com> E-mail: sales@add-furnace.com

Dimensions
MPA 4112 PF

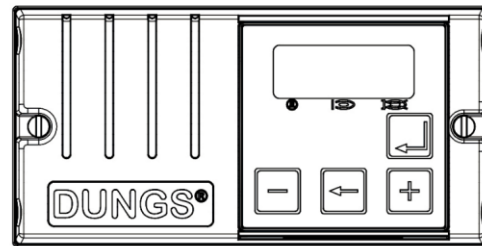
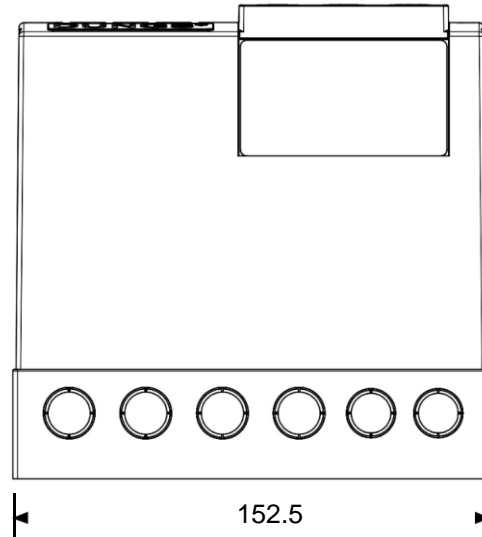
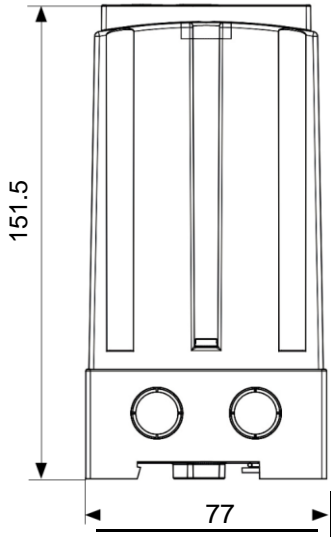



Installation of the MPA 41xx

Installation options for the MPA 4122 PF:

- direct screw connection of the housing on the installation surface using M4 screws, length min. 20 mm

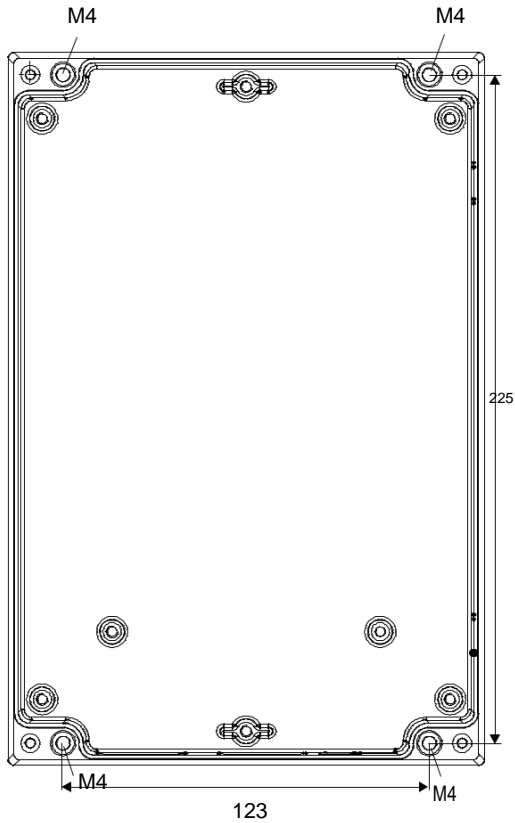

Dimensions of the MPA 4122 PF

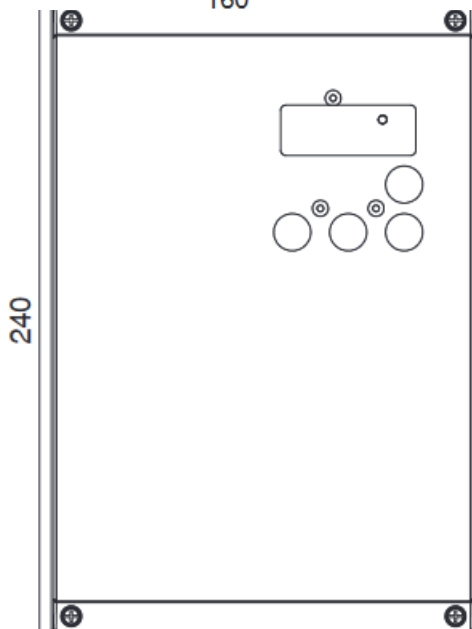
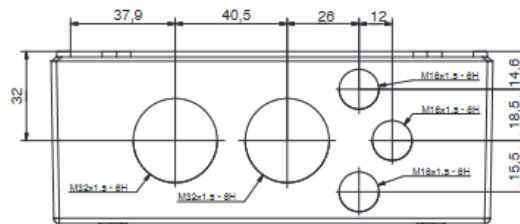
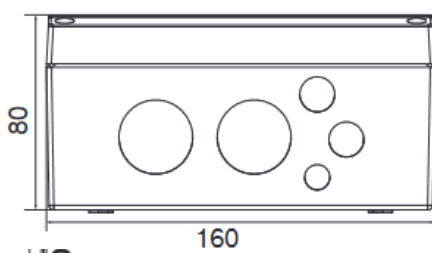



Description of the functions

Unlocking function

When the MPA is locked (state 0), it can be unlocked by pressing the unlock key. In order to distinguish the function from possible EMC interfering impulses, the key must be kept depressed for at least 0.5 s (max. 5 s).

The same applies to the unlocking via 230 V and to the unlocking via fieldbus modules.

According to DIN EN 14459 (annex J), the number of possible unlocking processes is limited to 5 in 15 minutes, that means the automatic system denies further unlocking if the MPA has been unlocked more than 5 times within a short time period. Only after a waiting time during which the MPA is provided with energy is it possible to unlock the MPA again.

The waiting time is 15 minutes or 3 minutes for each unlocking.

Extended unlocking

The described limitation to 5 unlocking operations in 15 minutes can be reset by means of "Extended unlocking". To do this, the unlock key must be pressed for at least 5 s (max. 10 s) (after 5 sec-onds, the display will start flashing).

The "Extended unlocking" is active in all operational states of the MPA, that means that a safety shutdown with restart of the MPA in operation can be carried out via the "Extended unlock-ing" also in the presence of a flame.

The "Extended unlocking" function is not possible via the 230V unlocking input or the fieldbus modules!

Access level

Write access to MPA is defined on different access levels.

Each parameter is assigned an access level. In order to modify a parameter, the MPA must be at the assigned or higher level.

If the access level is not sufficient to modify a parameter, the VisionBox indicates it, or a message is output on the MPA display prompting the user to enter the valid password. At higher levels, the users must press a key to confirm that they are "on site". The display is flashing for 30 s until a key is pressed; otherwise, the MPA remains in the previous level.

To change the access level, the correct password must be entered via the display or VisionBox → MPA settings →

Access level. The access level is automatically reset after 5 hours or after power failure. Exception: If the automatic system performs a restart during these 5 hours, for example due to an error, these 5 hours for the current access level are counted again from the beginning.

NOTICE

We recommend resetting the access level after having configured the automatic system.

Level	Designation	Key confirmation required
1	Dungs	yes
2	OEM Expert	yes
3	OEM	yes
4	Service	yes
5	Operator	no



Gas valve V1 X13

The gas valve V1 switches depend-ing on the state, see line V1 in the flow chart.

V2 boost, energy interrupt X14 The output can be used as V2 boost function, as energy interrupt function or as "HT active".

Configurable via parameter P80: Depending on the parameter value, another line in the flow chart is valid.

Flame detector

See Annex Flame detector.

Air pressure switch X18

The input can be used for the connec-tion of an air pressure switch. Configur-able via param-eters P84 and P16.

HT signal, gas pressure switch or POC X17

The input can be configured via param-eter P18. The high temperature NC signal can be connected to the input. If this function is used, the X16 must be assigned to the respective inverse signal (NO).

As an option, the input can be used for the connection of a gas pressure switch or as POC function.

Parameterisation mode (manual operation)

A switch in the connection chamber is used for switching between param-eterisation and automatic mode. The MPA registers a switching opera-tion not before a restart.

After connecting the mains supply, a messages is prompted on the display in the parameterisation mode request-ing you to enter the code. Enter the password for service or OEM level.

After having changed the level, the se-lected parameters are activated one af-ter the other. An overview of the param-eters and their order can be found in section Parameterisation display. The parameter values may be modified by pressing the keys + and -. The unlock key is used for saving the displayed value. Press the ← key to return to the previous position or parameter.

As the display has two positions only, some values are represented in an optimised resolution. If the set value cannot be displayed in this resolution, the display shows "— —". The value may be changed in a resolution that can be displayed.

Once all parameters are set, all values must be confirmed once again. This completes setting the parameters (H5 is displayed) and the parameter switch can be reset to "Auto" position.

If you do not press any key for 30 minutes in parameterisation mode, the program tries a restart.

Switch to "Auto"

With this switch position, the MPA is working in normal operation. If moni-tored parameters were changed and not released, the MPA switches to fault mode with 0x60 error.

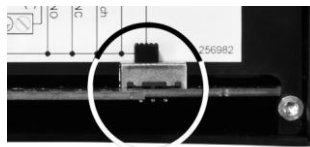

Parameter switch
Left "Auto" position
Right "Para" position



Flow Chart

State Number:	State Display Info:	Mode:	Parameter:	Maximum time:	Safety Chain	Heat Request	Flame 1	Flame mode	Proof-of-closure (on V1)	Gas pressure	Air Sw In	V1 Out	V2 Boost	Energy interrupt	HT active	Op0: heat request wait	Op5: pre-purging	Op3: flame on	Op1: flame op stable	Op2: HT op stable	Op4: operate (any mode)	Air Boost	Reaction on ABO, Bit 3	Ignition Out	Air Out	Alarm Out	Internal signals	Watchdog	Ionisation input active
0	Menu	*A		0..																									
1	Manual operation - Pause 1 (H5)			30m																									
2	Main switch-on delay			10m																									
3	Activate standard position			300s																									
4	Internal state			3s																									
5	Watchdog loading phase			3s																									
6	Idle state control air pressure sw.			60s																									
7	Waiting for heat request			24h																									
8	External light monitoring			60s																									
9	Waiting for air pressure			60s																									
10	Pre-purge			68m																									
11	Pre-ignition			10m																									
12	First safety time of flame detection			14.5s																									
13	Flame A stabilisation			0.5s																									
14	Stabilisation			10m																									
15	Operation			24h																									
16	Post-purge			68m																									
17	Extraneous light			68m																									
18	Restart protection			68m																									
19	Activate checking operation			10s																									
20	Activate operation HT			300s																									
21	Internal state			10s																									
22	Activate operation HT			300s																									
23	Activate checking start			10s																									
24	HT idle state control			300s																									
25	HT idle state control air press. sw.			60s																									
26	HT waiting for heat request			24h																									
27	HT external light check			60s																									
28	HT waiting for air pressure			60s																									
29	HT pre-purge			300s																									
30	HT stabilisation			300s																									
31	HT mode			24h																									
32	HT post-purge			68m																									
33	HT restart protection			68m																									
34	Lack of gas pressure switch mfn.			0..																									
35	Safety chain open			68m																									

Caption see page 23

**Legend:**

	Off		Must be off by end of state
	On		Must be on by end of state
	Don't care		Wait until input off, Fail > t_{max}
	Inexistent		Wait until input on, Fail > t_{max}
	Output depends on flag in bus signal		

- *A) Failure / Lock-out mode
*B) Jump from flame to HT mode
- *1) Operation mode High-temp. is detected by both terminals X16 and X17 as an EXOR signal and mode transition is after a tolerance time of 1 s. High-temp mode is selected or disabled by parameter P86.
*2) If the system changes to HT mode (>1 s) while operating in flame mode, the sequence jumps to the 4 states marked with "Ab", then jumps directly to state "HT stabilize".
*3) If the system changes to flame mode (>1 s) while operating in High-temp mode, the sequence jumps to state "Standard position" and the burner starts in flame mode.
*4) Parameter P84 (with respect to P19, P80) determines the function of input terminal X18 and P16 determines the states for supervision of the air switch.
*5) If flame signal appears during state-"HT operate", the sequence jumps, if air boost or V2 boost is active to the four states marked with "Ab" and then jumps directly to state "HT stabilize".
The number of HT recycle attempts per start/stop sequence for air boost, or V2 boost due to flame appearance is limited by parameter P81.
After the last possible recycle attempt (P81) the burner stays in operation and a warning message via bus and display is generated.
Flame appearance at type energy interrupt will generate also a warning message via bus and display. The burner stays in operation.
The warning message and display information will disappear while HT startup sequence (end of state "b1"), and after a switch to flame operation.
A tolerance time of P42 is accepted. If the flame appears and disappears for a period shorter than the time specified in P42 no action will follow
- *6) The action of the output at terminal X11 is selected by parameter P19.
*7) The action of the output at terminal X14 is selected by parameter P80.
*8) The flame signal must be constantly off for a minimum time of 5 s before advancing to the next state and if not achieved within 1 minute during state, then Fail.
*9) The flame (ionization) input is safety relevant for flame operation mode, non safety relevant in High temp operation mode.
*10) The states marked with "Ob" are necessary after a system restart (i.e. after power on, 24-hour self-check, ...).
*11) After the initialization states and with the system still in HT operation mode, the sequence jumps to the 2 states marked with "Ob".
*12) When the heat request comes back ON after a normal shut down, the sequence skips the 2 states marked with "Ob"-and goes to "HT Check improper flame".
*13) If the time since the last self check exceeds the time in parameter P82, the sequence will jump to do all self checks when the "heat request" is off.
*14) This action resets the automatic 24 hour self check operation time (see note *15). For self checks, the sequence jumps to the state "Standard position".
The "Power on start delay" state is executed for the duration specified in parameter P83 only after power on.
*15) When the start sequence is initiated from a safety shut down, the duration of this state is <0.5 s.
*16) If the elapsed time exceeds 24 hours since the last self check, the sequence forces a normal shutdown, performs the self checks, and then starts again if the heat request is still active.
*17) Terminals X17 and X18 input functions tolerates faulty signals of up to 1 s. The Proof-of-Closure signal is tolerated for 1.5 s.
*18) Terminal X14 for V2 boost can be independent of Air boost on terminal X11.
*19) If the High-temp mode is ON during the marked flame state, the sequence jumps to the HT mode states marked with "Ob"
*20) If P95 is set to 0 the flame input is ignored completely while HT operation (no check for improper flame and no check of flame appearance)
*21) The air output depends on a flag in the field bus signal. If no field bus is available the air output is off in this states.
*22) Terminal X11 depends on a flag in the field bus signal (AB0 Bit 3). If no field bus is available terminal X11 is off.
*23) No error is saved to the error history if gas pressure check fails

**State description****MPA 41xx PF**

State xx	Designation	Description
00	Error(Fxx)	If the automatic system is in this state, there is an error. The display automatically shows an error message and indicates the current error (e.g. "F 11") instead of the state number. The air valve (X 8) can be switched on and off by means of a bus command.
01	Manual operation - Pause 1(H5)	If the switch is on "Para" for the parametersation mode, the MPA stops in this state. The user must confirm the indicated parameter by pressing the "Next" key (unlock key). If you do not press any key during 30 minutes, the automatic system restarts or indicates an error. If you reset the parameter switch before reaching the H5 display and you have modified parameters, they are not yet applied, and the automatic system indicates an error.
02	Mains switch-on delay(00)	After having switched the mains on, the MPA has to wait for a defined time before going to the next state, see chapter P83: Duration of the switch-on delay after having switched the power on.
03	Activate standard position(00)	From this state on, the gas pressure is checked P18: Operating mode X17. If no pressure is active, the MPA goes into the low gas state without displaying an error message (i.e. no FM lock).
04	Internal state	
05	Watchdog loading phase(01)	A check is carried out whether the safety chain is still open. If this is the case, the state 35 "Safety chain open" is activated. If the safety chain is OK, the safety-relevant watchdog circuit is activated. When opening the safety chain after the activation of the WD relay until the restart protection HT, a safety shutdown takes place, the restart attempt depends on P15: Locking with open safety chain.
06	Idle state control air pressure switch (A4)	Depending on the operating mode of air pressure switch (P16), it is checked whether air pressure switch reports "no air pressure". The maximum state time is 60 seconds. If the idle state of the air pressure switch is not reached within this period, a safety shutdown followed by a restart attempt takes place or the automatic system displays a fault if the FM mode is active, see P22: Configuration of the FM mode. If the HT mode is allowed (P18 and P86 correctly configured), the system reacts to a HT signal and goes into the HT mode via the states "0b" (state 23 and 24).
07	Waiting for heat request(A0)	The automatic system is ready for operation, but there is no heat request. Out of this state, the MPA can start a voluntary self-test, see P82: Self-test. The air valve (X 8) can be switched on and off by means of a bus command. Until this state is reached, the MPA always goes to the low gas state without displaying an error message in case of missing gas pressure. If the HT mode is allowed (P18 and P86 correctly configured), the control reacts to a HT signal and goes into the HT mode via the states "0b" (state 23 and 24).

* In () on display



State description

MPA 41xx PF

State xx	Designation	Description
08	External light monitoring (A1)	The flame may not be detected within the state time of max. 1 min. Otherwise, the automatic system tries to restart.As of this state, the air valve is active and cannot be deacti-vated via the bus.
09	Waiting for air pressure (A1)	If the MPA is configured for the connection of an air pressure switch via X18, see operating mode X18, the air pressure must be active within a state time of max. 60 s. Otherwise a safety shutdown followed by a restart attempt depending on P22 takes place (see P22: Configuration of the FM mode).An external light control can be made for the entire duration of this state.
10	Pre-purge (A1)	This state provides sufficient pre-venting. For the duration defined in parameter pre-venting, see P30: Duration of pre-venting. An external light check can be made for the entire duration of this state.Up to this state, a jump is made to the restart protection flame in case of a missing heat request.If the HT mode is allowed (P18 and P86 correctly configured), the system reacts to a HT signal and goes into the HT mode via the states "Ob" (state 23 and 24).
11	Pre-ignition (A1)	The ignition is activated (terminal 15) for the duration speci-fied in parameter P31 without opening valve V1.If from this state on the heat request ceases to exist, the flame post-venting is activated.
12	First safety time of flame detection (A1)	The gas valve V1 is opened in this state. Gas flows and a flame can be generated. The duration of this state is P32 - 0.5 s.
13	Flame A stabilization (A1)	After deactivating the ignition, the process for flame detection is started. If an ionisation current is detected, the MPA reports a flame. The duration of this state is 0.5 s.
14	Stabilisation (A2)	The flame can stabilise in this state. The duration of this stabi-lization phase is configured via P34, (stabilisation time).If the HT mode is allowed (P18 and P86 correctly configured), the system reacts to a HT signal and goes into the HT mode via the states "Ab" (states 19 to 22).
15	Operation (A3)	The automatic system is now operating. After 24 hours in this state, a forced regular shutdown is auto-matically carried out because the MPA works in the intermittent operation.If the HT mode is allowed (P18 and P86 correctly configured), the automatic burner control reacts to a HT signal and goes into the HT mode via the states "Ab" (states 19 to 22). If the heat request ceases to exist, the MPA goes into the post-vent-ing state.
16	Post-purge (A4)	In this state, the post-venting of the combustion chamber is carried out, see P51: Post-venting time. The gas valves re-main closed from this state on. The air valve remains open in this state; it is switched off in the next one.
17	Extraneous light time (A4)	During this time (P50-P51 if > 0), a flame signal may be pre-sent from the previous mode caused by e.g. existing residual gas in the combustion chamber. The external light monitoring is only started in the following state.The after-burn time starts in the post-venting state if the post-venting is equal to or greater than the after-burn time; then the after-burn time state is skipped.



State description		
MPA 41xx PF		
State xx	Designation	Description
18	Restart protection (A4)	In this state, the system waits until parameter P52 is finished; this prevents an immediate restart of the automatic system if a heat request is active. The flame may no longer be detected in this state; otherwise, MPA reports an external light error.
19	Activate checking operation (Ab)	If the HT signal is deactivated from this state on, the MPA goes into the post-venting HT since the gas valves are open. The states 19, 20, 21 and 22 are carried out one after the other. Afterwards the state 30 Stabilisation HT becomes active.
20	Activate operation HT (Ab)	The state time is configured with P87. If the V2 boost function is active, see P80: Operating mode X14, the X14 output is activated for this state duration.
21	Internal state	
22	Activate operation HT (Ab)	After this state, a changeover to the the stabilisation of the HT mode takes place.
23	Activate checking start (Ob)	A jump to this state takes place after a power up or a restart or if the burner is not yet in the flame operation when a signal is sent by HT.If the HT signal is deactivated from this state on, the MPA goes into state 3 (activate standard position).
24	Activate start HT (Ob)	After the end of the time in parameter P87, the state Idle state control air pressure switch for HT mode is activated.
25	HT idle state control air pressure switch (b4)	Depends on the operating mode of the air pressure switch, see P16: Operating mode air pressure switch, the air pressure in different states is monitored. This parameter setting defines whether an idle state control is carried out in this state. The maximum state time is 60 s. If the idle state of the air pressure switch is not reached within this period, a safety shutdown followed by a restart attempt takes place or the automatic system displays a fault if the FM mode is active, see P22: Configuration of the FM mode.
26	HT waiting for heat request (b0)	The automatic system is in the HT mode ready for operation, but there is no heat request.Out of this state, the MPA can start a voluntary self-test, see P82: Self-test.The air valve (X 8) can be switched on and off by means of a bus command.
27	HT external light check (b1)	If activated for the HT mode, a flame must not be detected within the state time of max. 60 s, see P95: HT: External light monitoring.If a flame is detected after this time period, a safety shut-down followed by a fault lock takes place.As of this state, the air valve is active and cannot be deactivated via the bus.
28	HT waiting for air pressure (b1)	If the MPA is configured for the connection of an air pressure switch via X18, see P84 operating mode X18, the air pressure must be active within a state time of max. 60 s. Other-wise a safety shutdown followed by a restart attempt depending on P22 takes place: Configuration of the FM mode.During the entire duration of this state, an external light check is carried out if activated for the HT mode, see P95: HT: External light monitoring.
29	HT pre-purge (b1)	This state provides sufficient pre-venting. For the duration defined in parameter pre-venting, see P85: Pre-venting time HT. During the entire duration of this state, an external light check is carried out if activated, see P95:Up to this state, a jump is made to the restart protection flame in case of a missing heat request.



State description		
MPA 41xx PF		
State xx	Designation	Description
30	HT stabilisation(b2)	The HT mode can stabilise in this state. The duration of this stabilization phase is configured via P89.If from this state on the heat request ceases to exist again, the HT post-venting is activated. If the HT signal is deactivated from this state on, the MPA goes into the post-venting HT.
31	HT mode(b3)	The automatic system is now in the HT mode. After 24 hours in this state, a forced regular shutdown is automatically carried out because the MPA works in the intermittent operation.During the entire duration of this state, an external light check is carried out if activated, see P95: HT: External light monitoring. If a flame has been detected, attempts are started to blow it out according to the burner type, see chapter P81: anti-oscillation counter for flame detection during HT. If the heat request ceases to exist, the MPA goes into the post-venting HT state.
32	HT post-purge(b4)	In this state, the post-venting of the combustion chamber is carried out, see chapter P90: HT post-venting time. The gas valves remain closed from this state on. The air valve remains open in this state; it is switched off in the next one.
33	HT restart protection(b4)	In this state, the automatic system waits until parameter P91 is finished; this prevents an immediate restart of the auto-matic system if a heat request is active again.
34	Lack of gas gas pressure switch min(d2)	If the automatic system is configured for the use of a gas pressure switch (see P18: operating mode X17), a changeo-ver to this state is carried out from all states as soon as a low gas flow is detected. It leaves it in state 3 after sufficient gas pressure has been built up. After having waited for a heat request, the MPA generates an error message during the jump from all states.
35	Safety chain open(d1)	The automatic system remains in this state during the time set in parameter P20 if the system does not detect a closed safety chain. After the time has lapsed, it decides based on P15 whether it locks immediately or tries to restart. If the safety chain is closed before the time of P20 has lapsed, the MPA changes to state 3 to check the safety chain again in state 5.



Parameter

Parameter change

Parameter types

1-bit parameter (U1) - setting 0 and 1 (displayed as ON/OFF), no limits

8-bit parameter (U8) - value setting within variable limits

16-bit parameter (U16) - value setting within variable limits.

A parameter may be modified on the display of MPA or via the VisionBox software on a PC.

In order to change a parameter, you need to set the access level assigned to the parameter.

The value must be within the variable limits; a value outside these limits is not possible.

Depending on the access level, it is possible to change the variable upper and lower limits. The variable limits may only be changed by means of VisionBox, not on the MPA display. The variable limits are restricted by means of fixed limits. These fixed limits cannot be changed.

To change parameters that cannot be changed during normal operation, it is necessary to change to state "Waiting for heat request".

Most of the parameters are monitored in automatic mode (switch on the board on "Auto"). The MPA detects changes of the values and immediately changes to fault lock (error 0x60). Any value changes must be released in the parameterisation mode of a manual program run (see also parameter table).



Parameter			
Parameter description			
Parameter	Designation	Description	Setting / Examples
P11	Field bus address configuration	Setting the bus slave address of MPA. If an invalid address for the connected bus module is set and the MPA is in automatic mode, it restarts (error 0x18). If an invalid value for the connected bus module is set and the MPA is in parameter mode, an error message is generated. During operation and error messages, the current bus address may be seen by pressing the ← key.	Value range: OFF (no fieldbus available) 1 to 254 (e.g. Profibus adjustment range from 1 to 126) Note: A modified value for this parameter is not applied before a restart.
P12	Number of restart attempts or anti-oscillation counter	Number of restart attempts of the MPA. After a failed last start, the MPA locks in fault switch-off (state 0 "error"). The anti-oscillation counter is reset when returning to operating state or when unlocking the MPA.	Value range: 0-5 attempts
P13	Number of restart attempts when flame is missing after the start-gas flame proving period	The number of restart attempts after creating a flame (P12) can be limited for the case that the flame is still missing after the first safety time for start-up. The restart counter and the anti-oscillation counter are reset when changing to the operating state or after unlocking.	Value range: 0-5 attempts Example: P12 = 5, P13 = 1 Flame is still missing after the first restart → 1. Restart attempt → Error idle state control LDW → 2. Restart attempt → Error idle state control LDW → 3. Restart attempt → LDW OK after the third attempt, there is still no flame → Automatic system is locked although the number of re-start attempts (P12) has not yet been reached but the number of restart attempts after missing flame has been reached.
P14	Number of restart attempts after a flame-out or missing flame after the second safety time for start-up	The number of restart attempts (P12) can be limited for the case that there is a flame lift-off or that the flame is still missing after the safety time for start-up. The restart counter and the anti-oscillation counter are reset when changing to the operating state or after unlocking.	Value range: 0-5 attempts Example: P12 = 5, P14 = 1 Missing flame during operation → 1. Restart attempt → Error idle state control LDW → 2. Restart attempt → Error idle state control LDW → 3. Re-start attempt → After the third attempt LDW OK, there is still no flame → Automatic system is locked.
P15	Locking with open safety chain	If the safety chain is not closed, the MPA waits in state 35 (safety chain open). If the adjustable time (P20) has lapsed and the safety chain is still open, the system changes to fault lock due to an error or restarts (depending on the anti-oscillation counter).	This setting is also valid if the safety chain is opened after state 4. Setting: 0: Restart attempt depending on the anti-oscillation counter 1: Immediate fault lock



Parameter			
Parameter description			
Parameter	Designation	Description	Setting / Examples
P16	Air pressure switch: Operating mode	The air pressure monitoring can be made in eight different state ranges • Idle state control flame mode (state 6) • Flame operation (states 14 and 15) • Start flame operation (states 9 to 11). • Post-venting flame (state 16) • Idle state control HT mode (state 25) • HT mode (states 30 and 31) • Start HT mode (states 28 and 29) • Post-venting HT (state 32)Several ranges can be activated at the same time. For this, the respective values must added in the column "Value" and the total must be entered in P16.	e.g. monitoring desired for • Idle state control Flame mode = 1 • Idle state control HT mode = 16 • HT operation = 32 Value for P16 = 1 + 16 + 32 = 49 Setting 0 to 255

Value	Function
1	Monitoring of the idle state control in the flame mode
2	Monitoring in the flame mode
4	Monitoring during the start phase of flame mode
8	Monitoring during the post-venting of flame mode
16	Monitoring of the idle state control in the HT mode
32	Monitoring in the HT mode
64	Monitoring in the start phase of HT mode
128	Monitoring during the post-venting of HT mode



Parameter			
Parameter description			
Parameter	Designation	Description	Setting / Examples
P17	Temperature controller operating mode	This parameter can be used to configure the behaviour of the MPA and the way it accepts the heat request via bus or via the HW input Heat request/temperature controller (X19).	<p>Setting 0: Only the hardware input Heat request is active, the bus signal Heat request is ignored. Note: With this setting, the air purge (bus signal) cannot have priority over heat request (P241 Bit0 = 1), this will lead to error configuration, see errors from the basic system for error 0x18</p> <p>Setting 1: The bus signal Heat request is active, the burner can only be started if the HW signal is also active. If the bus connection is interrupted, the MPA is switched off in a regular way after a tolerance time of 10 s.</p> <p>Setting 2: The bus signal Heat request is active. If the bus connection is interrupted, the control system is switched to the HW signal after a tolerance time of 10 s.</p> <p>Setting 3: The bus signal Heat request is relevant. If the bus connection is interrupted, the MPA is switched off in a regular way after a tolerance time of 10 s.</p> <p>Setting 4: The bus signal Heat request is relevant. If the bus connection is interrupted, the MPA performs a safety shutdown with fault lock after a tolerance time of 10 s.</p> <p>ATTENTION: In contrast to Profibus, Modbus is not equipped with a cyclic communication. The MPA, however, waits for one Modbus request per minute, therefore an interrupted communication cannot be detected immediately. If the request is missing, the bus module reports the automatic system that there is a bus interruption and F9 flashes on the display. Only after this the parameter P17 becomes active.</p>



Parameter			
Parameter description			
Parameter	Designation	Description	Setting / Examples
P18	Operating mode X17	This parameter defines whether HT mode is used, a gas pressure switch is connected or a Proof of closure contact (POC).	<p>Setting 0: Input has no function, the HT mode is deactivated.</p> <p>Setting 1: HT NC mode, therefore the signal on X16 must be inverse. This setting enables the HT mode.</p> <p>Setting 2: The input is used for the connection of the gas pressure switch, the HT mode is deactivated.</p> <p>Setting 3: The input is used for the POC signal for valve V1, the HT mode is deactivated.</p>
P19	Configuration of the output mode	The output may be switched on in different states by means of the following parameter settings. On means 115 VAC or 230 VAC, for all others, Off, i.e. 0V.	<p>Setting 0: "Waiting for heat request": Output is on in state 7 (Waiting for heat request) and in state 26 (HT waiting for heat request).</p> <p>Setting 1: "Flame stable" output is on in state 15 (operation).</p> <p>Setting 2: "HT stable" output is on in state 31 (HT mode).</p> <p>Setting 3: "Flame on": Output is on from state 14 (stabilisation) to state 15 (operation).</p> <p>Setting 4: "Operation": Output is on in state 15 (operation) and in state 31 (HT mode).</p> <p>Setting 5: "Pre-venting": Output is on in state 10 (pre-venting) and in state 29 (HT pre-venting).</p> <p>Setting 6-9: reserved</p> <p>Setting 10: "Air boost": Output is on in state 20 (Activate operation HT).</p> <p>Setting 11: Depending on the bus: The output depends on the bus, that means if bit 3 is set to AB0, the output is switched on, independently of the state of the MPA, even if it reports a fault.</p>



บริษัท เอดีดี เฟอร์เนส จำกัด

ADD FURNACE CO.,LTD.

44 ซอยบรมราชชนนี 70 ถนนบรมราชชนนี แขวงศาลาธรรมสพน์ เขตทวีวัฒนา กรุงเทพฯ 10170

โทร: 02-888-3472 โทร: ออกแบบ:08-08-170-170 แฟกซ์: 02-888-3258

https://www.add-furnace.com E-mail: sales@add-furnace.com

Parameter			
Parameter description			
Parameter	Designation	Description	Setting / Examples
P20	Duration safety chain open	This parameter can be used to define the duration of state 25 (safety chain open). Time until the automatic system restarts or changes to lockout, depending on the anti-oscillation counter and P15 (locking with open safety chain).	Value range: 0 to 65534 (resolution in 1/16 s). 65535: Infinite state duration
P22	FM mode	Immediate fault switch-off in case of: Lack of gas, error limit switch main gas, Error of idle state control air pressure switch and error no air pressure	Setting 0: not active Setting 1: active
P30	Duration of pre-venting	This parameter can be used to define the duration of state 10 (pre-venting).	Value range: 0 to 65534 (resolution in 1/16 s).
P31	Duration of pre-ignition time	This parameter defines the duration of state 11 (pre-ignition). During this time, the ignition is already active, the gas valve is closed.	Value range: 2 to 65534 (resolution in 1/16 s).
P32	Safety time for start-up / first safety time	Defines the duration of the safety time for start-up. Maximum time from opening the gas valves to detecting a flame. NOTE: This duration is divided into states 12 and 13. State 13 is always 0.5 seconds.	Value range: 16 to 240 (resolution in 1/16 s). Attention: With FM applications, the following times must not be exceeded. Burners with direct ignition: < 2,500,000 Btu/h ≤ 15 s (set value max. 240) > 2,500,000 Btu/h ≤ 10 s (set value max. 160)
P34	Stabilisation time A	Duration of state 14 "Flame A stabilisation"	Value range: 0 to 65534 (resolution in 1/16 s).
P41	Operation safety time	Defines the duration of the safety time for MPA during operation for flame 1. Time until gas valves close when there is not any flame.	Value range: 12 to 56 (resolution in 1/16 s). ATTENTION: The entire reaction time after there is not any flame during operation is combined of P41 and possible reaction times of external flame detectors, see Annex Flame detector.
P42	HT tolerance time flame signal	If a flame is detected in the HT mode for a longer period than the tolerance time, the MPA goes to state 19 and tries to "blow out" the flame. Operating modes in which the flame is blown out (in the remaining operating modes, the MPA does not change its state): - Air boost on X11, see P19 - V2 boost on X14, see P80 If it is not successful, the process is repeated, see P81: anti-oscillation counter for flame detection during HT. The flame detection during HT can be deactivated, see P95: HT: External light monitoring.	Setting 12 to 80 (resolution in 1/16 s) NOTE: The parameter value is the minimum reaction time. Depending on the marginal conditions, the actual reaction time can be extended.



Parameter			
Parameter description			
Parameter	Designation	Description	Setting / Examples
P50	Extraneous light	Defines the duration of the after-burn time (state 17), the time metering starts already during the post-venting (state 16). That means that if the after-burn time is shorter/equal to the post-venting time, the state after-burn time is skipped.	Value range: 16 to 65534 (resolution in 1/16 s).
P51	Post-venting time	Defines the duration of the post-venting time (state 16).	Value range: 0 to 65534 (resolution in 1/16 s).
P52	Restart protection	Defines the duration of the restart protection (state 18).	Value range: 0 to 65534 (resolution in 1/16 s).
P80	Operating mode X14	This parameter defines the function of the output X14 and, therefore, the burner type.	Setting 0: reserved Setting 1: High temperature active Setting 2: V2 boost Setting 3: Energy interrupt
P81	Anti-oscillation counter with flame detection during HT (8-bit parameter)	If the flame detection is active during HT (P95: HT: external light monitoring), the attempt is made considering the tolerance time of the flame detection (HT: tolerance time flame signal) to "blow out" the flame. The number of attempts is configured via parameter P81. If the number of attempts is reached, the MPA remains in the HT mode, a warning is transmitted to the display (see Error from processor 2) and via fieldbus (see Input data of the master from the MPA). The error message is reset at the end of the state of the HT preventing, that means after the regular shutdown and a subsequent restart in the HT mode. Moreover, it is also reset after having changed to the flame mode in the watchdog loading phase state. The attempts for energy interrupt are not carried out, the MPA remains in operation and the warning is immediately emitted. The parameter has no effect for these burner types (P80: operating mode X14).	Setting 0 to 5



Parameter			
Parameter description			
Parameter	Designation	Description	Setting / Examples
P82	Self-test	Since the MPA41xxPF is an intermittent automatic system, a self-test must be carried out every 24 h (jump to state 3 and internal self-test). This parameter can define a time at which the MPA is to perform a premature, voluntary self-test if it is in the Wait for heat request state (flame or HT) in order to avoid a later interruption of the heat request. If the MPA remains in operation for a longer period than defined in the parameter, a forced shutdown followed by a self-test is carried out.	Setting 1 to 1439 (resolution in 1/16 s).
P83	Duration of the switch-on delay after power On (16-bit parameter)	After having switched on the mains, the automatic system waits for a time period defined in P83, that means that the switch-on is delayed. In case of a safety shutdown followed by a restart or an unlocking after a fault, there is no waiting time and the parameter has no effect.	Setting 0 to 9600 (resolution in 1/16 s).
P84	Operating mode X18	Defines the function type of the input X18	Setting 0: Input for the connection of an air pressure switch, the parameter P16 (P16 operating mode Air pressure switch) that defines the monitoring areas must be observed. Setting 1: reserved Setting 2: reserved Setting 3: The input is ignored / no function
P85	Pre-venting time HT	This parameter defines the duration of state 29 (HT pre-venting).	Setting 0 to 4800 (resolution in 1/16 s).
P86	Operating mode HT allowed	This parameter can be used to prohibit the HT mode.	Setting 0: HT mode not allowed. The states of the HT mode cannot be reached even if the signal HT is active on X16 and X17. Setting 1: HT mode allowed.
P87	Jump duration from flame or power On to HT	Defines the duration for state 20. That means that the length of the boost function (if used) is defined via output X14 or X11.	Setting 16 to 4800 (resolution in 1/16 s).
P89	HT: Stabilisation time	Defines the duration of the state HT stabilisation time (state 30, HT stabilisation).	Setting 8 to 4800 (resolution in 1/16 s).
P90	HT: Post-venting time	Defines the duration of the post-venting time (state 32, HT post-venting).	Setting 0 to 65534 (resolution in 1/16 s).
P91	HT: Duration restart protection	Defines the duration of the restart protection (state 33, HT restart protection).	Setting 8 to 65534 (resolution in 1/16 s).



Parameter			
Parameter description			
Parameter	Designation	Description	Setting / Examples
P92	Maintenance interval WD	A counter counts the reactions of the watchdog relay in state 5 (watchdog loading phase). If the counter reaches the value defined in parameter P92*1000, a message is output via field bus (see chapter Input data of the master from the MPA) and via the display (see chapter Errors without error ID). The MPA, however, continues working. After maintenance work, the message can be reset via the display, see reset display.	Setting 1 to 65534 (resolution 1000).
P93	Maintenance interval V1	A counter counts the number of reactions of the relay V1. If the counter reaches the value defined in parameter P93*1000, a message is output via field bus (see chapter Input data of the master from the MPA) and via the display (see chapter Errors without error ID). The MPA, however, continues working. After maintenance work, the message can be reset via the display, see reset display.	Setting 1 to 65534 (resolution 1000).
P94	Maintenance interval air output	A counter counts the number of reactions of the relay for the air output. If the counter reaches the value defined in parameter P94*1000, a message is output via field bus (see chapter Input data of the master from the MPA) and via the display (see chapter Errors without error ID). The MPA, however, continues working. After maintenance work, the message can be reset via the display, see reset display.	Setting 1 to 65534 (resolution 1000).
P95	External light monitoring	This parameter can be used to deactivate the external light monitoring in the HT mode, that means that no "blow out attempts" are started because no flame is detected. The parameters P81 anti-oscillation counter for flame detection during HT and P42, HT: Tolerance period flame signal does not have any effect.	Setting 0 to 1
P240	Extension module	If an extension module is installed, this parameter must be set to >0, otherwise the MPA will perform safety shutdown with restart attempt with error 0x18.	Setting 0: Module not required Setting > = 1: Module installed



Parameter			
Parameter description			
Parameter	Designation	Description	Setting / Examples
P241	Bit functions priority switching Cooling/heating	Bit 0: OFF = heat request overwrites ventilation request, the MPA starts operation despite the ventilation request ON = ventilation request overwrites heat request If ventilation request is set (only via bus possible) in operation, the MPA shuts down in a regular way and waits for heat request with ventilation Note: If the bit is set, the setting of the heat request via HW input (P17=0) is not possible. This will lead to error configuration, see chapter Errors from the basic system for error 0x18. Bits 1-15 = no function	
P242-P249		Reserved parameters*	
P260 ff	Internal parameters	Please do not change!	

*P244 value must be "0"



Parameter							
Factory settings							
Parameter	Designation	Factory setting	Unit	Access level	Comfort parameter setting	Min. value	Max. value
P11	Field bus address configuration	255 = OFF		OPERATOR	x	0	255
P12	Number of re-start attempts or anti-oscillation counter	0		OEM	x	0	5
P13	Number of restart attempts when flame is missing after the start-gas flame proving period	0		OEM	x	0	5
P14	Number of restart attempts after a flameout.	0		OEM	x	0	5
P15	Locking with open safety chain	ON		OEM	x		
P16	Air pressure switch operating mode	255		OEM	x	0	255
P17	Temperature controller operating mode	2		OPERATOR	x	0	4
P18	Operating mode X17(NC, POC, gas pressure)	1		OEM	x	0	3
P19	Configuration of the output operating mode	4		SERVICE	x	0	255
P20	Duration of safety chain open	65635	1/16 s	OEM		0	65535
P22	FM mode	OFF		OEM			
P30	Duration of pre-venting	0	1/16 s	OEM	x	0	65534
P31	Duration of pre-ignition time	0	1/16 s	OEM	x	0	9600
P32	Safety time for start-up	16	1/16 s	OEM	x	16	240
P34	Stabilisation time A	16	1/16 s	SERVICE	x	0	9600
P41	Operation safety time	12	1/16 s	OEM	x	12	56
P42	HT Tolerance time Flame signal	16	1/16 s	OEM		12	80
P50	After-burn time	80	1/16 s	OEM		16	65534
P51	Post-venting time	0	1/16 s	SERVICE	x	0	65534
P52	Restart protection	8	1/16 s	SERVICE	x	8	65534



Parameter							
Factory settings							
Para- meter	Designation	Factory setting	Unit	Access level	Comfort parameter setting	Min. value	Max. value
P80	Operating mode output X14	2		SERVICE		0	3
P81	Anti-oscillation counter for flame detection during HT mode	0		SERVICE		0	5
P82	Self-test	1380	min.	SERVICE		1	1439
P83	Duration of switch-on delay voltage on	0	1/16 s	SERVICE	x	0	9600
P84	Operating mode output x18	0		OEM		0	3
P85	Pre-venting time HT mode	0	1/16 s	SERVICE	x	0	4800
P86	Operating mode HT On/Off	ON		OEM			
P87	Duration of voltage on or flame operation on HT mode	16	1/16 s	SERVICE	x	16	4800
P89	HT mode stabilisation time	16	1/16 s	SERVICE		8	4800
P90	HT mode post-venting time	0	1/16 s	SERVICE		0	65534
P91	HT duration re-start protection	8	1/16 s	SERVICE		8	65534
P92	Maintenance interval watchdog (WD)	250	1000	SERVICE		1	65534
P93	Maintenance interval V1	1000	1000	SERVICE		1	65534
P94	Maintenance interval output air	1000	1000	SERVICE		1	65534
P95	HT mode external light monitoring	OFF		OEM			
P240	Extension module yes/no	0		OEM		0	65535
P241	Extension module bit functions	0		OEM		0	65535



Status information			
MPA 41xx PF			
Designation	Description	displayed via VisionBox	displayed via display
General information			
Fault switch-off	Automatic system is locked	●	LED
State number	Current state of the automatic system, key combination + and -	●	7-segment
Current access level		●	
Flame	Flame detected	●	LED
Manual mode	Automatic system in manual mode	●	7-segment
Flame quality	Value > 49 good flame (for ionisation)	●	Info
Hardware input for temperature controller	Signal for temperature controller input	●	
Bus connection present	Connection OK	●	7-segment
Heat request	Signal combination from bus setpoint input and hardware input	●	LED
Fieldbus present debounced	10 s debounced signal	●	
Temperature controller (HW + parameter/bus)	Signal combination from bus setpoint input and hardware input	●	LED
Warning flame in HT	X18	●	Fx
Inputs			
Air pressure switch	Signal from input X18	●	
Flame 1	Signal from flame 1 input	●	
Signal HT-NO	Signal from input X16	●	
Signal HT-NC / Gas pressure switch / POC	Signal from input X17	●	
Outputs			
Valve 1	Output X13	●	
Output X14	Output X14 / V2 boost (energy int./HT active)	●	
Ignition	Output X15	●	
Fan	Output X8 (air valve)	●	
Output X11	Output X11	●	
Counter			
Useful life counter	Time since switching on the automatic system	●	
Runtime meter	Operating time flame operation, not resettable	●	
Runtime meter Resettable	Flame and HT resettable via VisionBox and display	●	Info
Resettable start counter	Start counter flame mode, resettable via VB and displ.	●	Info
Start counter	Start counter flame mode, not resettable	●	
Runtime meter HT	Operating time HT mode, not resettable	●	
Start counter HT	Start counter HT, not resettable	●	
Switching cycles counter WD	Switching cycles watchdog relay, resettable via display	●	
Switching cycles counter V1	Switching cycles V1 relay, resettable via display	●	
Switching cycles air valve	Switching cycles air valve, resettable via display	●	
Internal information			
State timer in minutes	Displayed state timer runs in minutes, otherwise in 1/16 sec.	●	
Initialisation phase	The automatic system is being initialised	●	
Multi-function switch	Is "ON" when unlock key is pressed	●	
Access level change	CCC or value flashes on display, ↵ key expected	●	7-segment
Safety switch-off flag	Automatic system is locked	●	
Error index	Internal error counter	●	
Remaining state time	is 65535 if unlimited remaining time	●	



บริษัท เอดีดี เฟอร์เนส จำกัด

ADD FURNACE CO.,LTD.

44 ซอยบรมราชชนนี 70 ถนนบรมราชชนนี แขวงศาลาธรรมสพน์ เขตทวีวัฒนา กรุงเทพฯ 10170

โทร: 02-888-3472 โทร: ออกแบบ:08-08-170-170 แฟกซ์: 02-888-3258

<https://www.add-furnace.com> E-mail: sales@add-furnace.com

Status information			
MPA 41xx PF			
Designation	Description	displayed via VisionBox	displayed via display
Cycl. state counter	Counts in 1/128 s cycle	•	
Processor load		•	
Nominal modulation degree	No function	•	
Actual modulation degree	No function	•	

LED: Indicated by one of the 3 LEDs on the display

7-segment: Indicated by one or several characters of the 7-segment display

Info: Displayed in informative display mode



Display

The customer may customize the MPA 41xx PF on the integrated display to match the desired burner.

All important parameters may be set by means of the four operating keys.

The parameters of the device are either set by means of VisionBox or by means of the parameterisation and service box.



3x7 segment display

LED:

Blue: Heat request

Yellow: Flame quality (fl ashes if the flame quality is poor)

Red: Fault



Release button

RESET function and confirmation of the entry

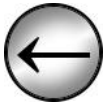

Back



Plus

Increases the displayed value











Minus

Reduces the displayed value

Depending on the operating state of the automatic burner control system, different information is displayed:



Overview of the display modes

Mode	Active
Operation display	in normal operation if no error is active.
Error display	if the automatic system is in fault lock.
Info display	From operation display by pressing a shortcut  and 
Display of the error memory	From operation display by pressing a shortcut  
Parameterisation display	From operation display by pressing a shortcut  
Reset display	From operation display by pressing a shortcut  
Flashing display	Depending on the display mode: <ol style="list-style-type: none">1. Request to confirm the access level change2. Keep the unlock key depressed for more than 5 s to restart the MPA ("Extended unlocking")3. Processor 2 error, see error list4. New password after password change5. Restart of the automatic system, all segments and LEDs are flashing



Display

▶ Displayed operating state for setting parameters and troubleshooting

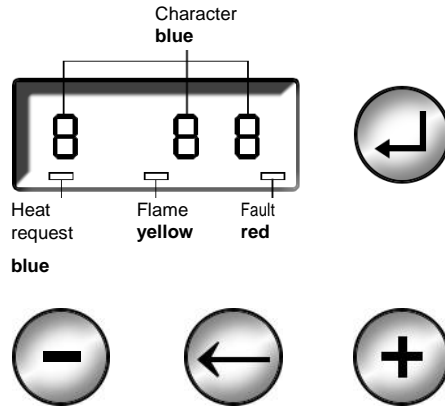

Attention

Observe indication on 7-segment display

1. Digits

6 = 6

8 = 8

0 = 0

2. Letters

B or b = b

D or d = d

O or o = o



11.7 Operating state

Operation display MPA 41xx PF

► Shows the operating state of the automatic system

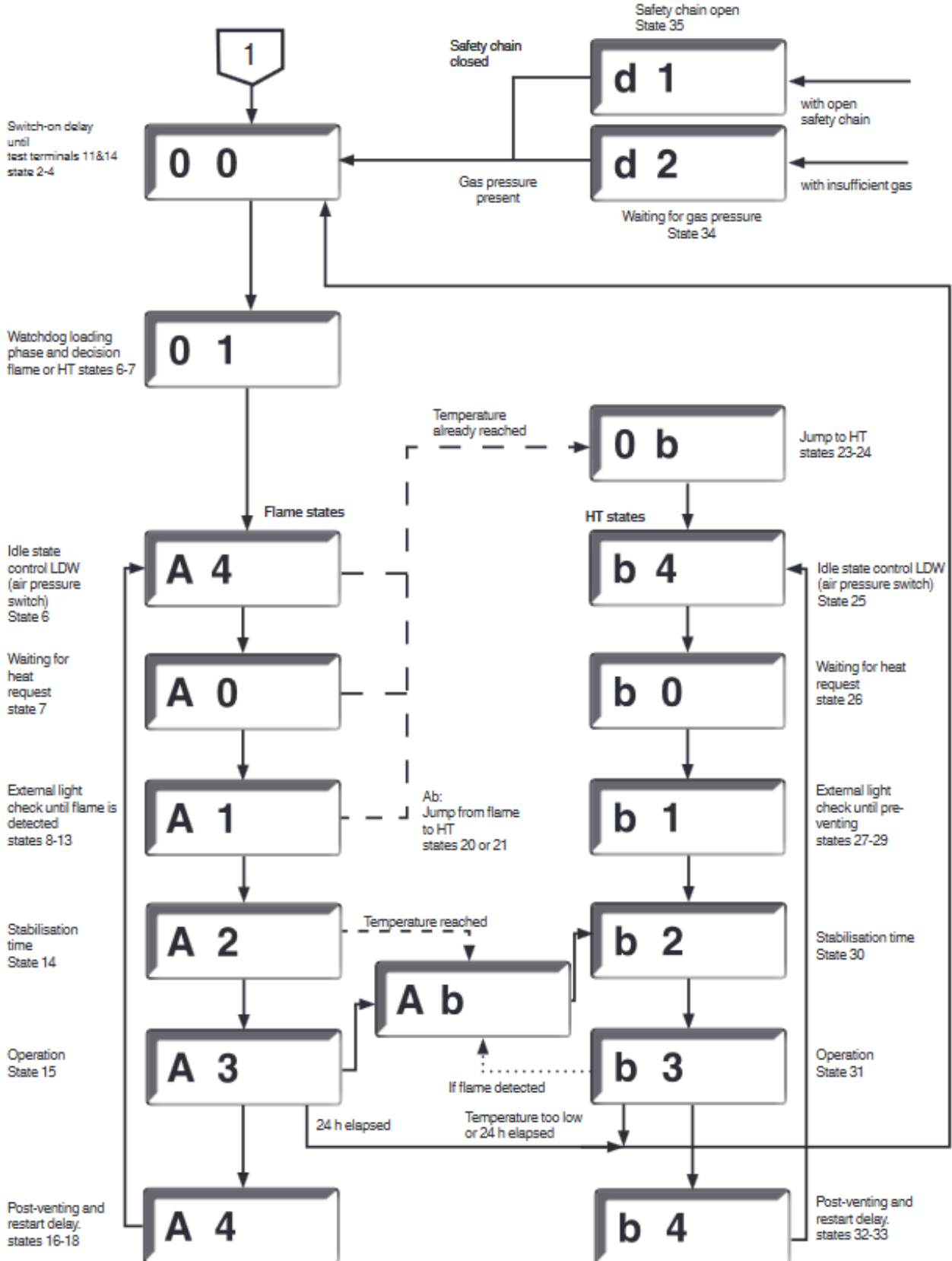



Operation display

Operation display additional information

▶ Display of state number

▶ Display and setting the bus address

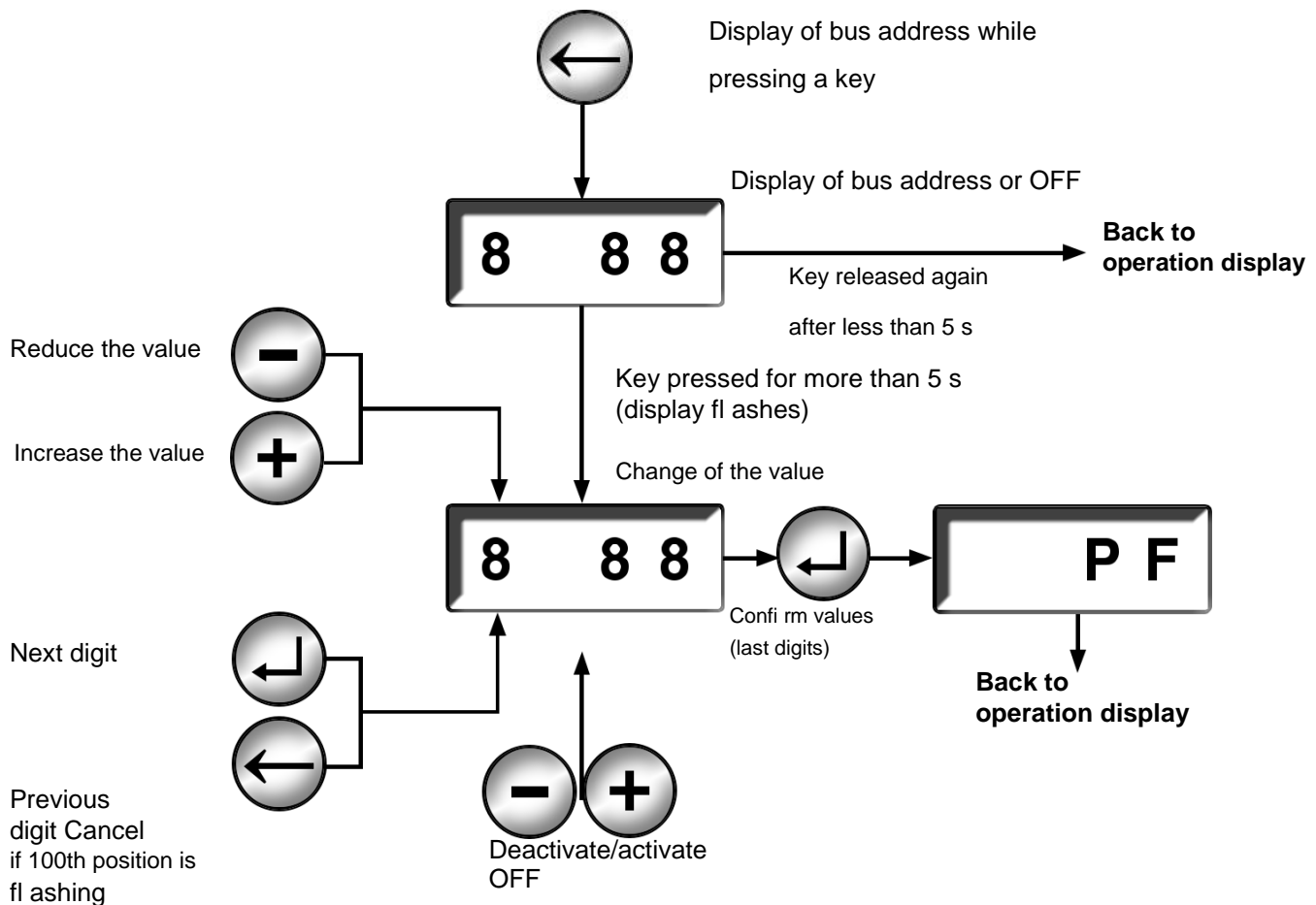
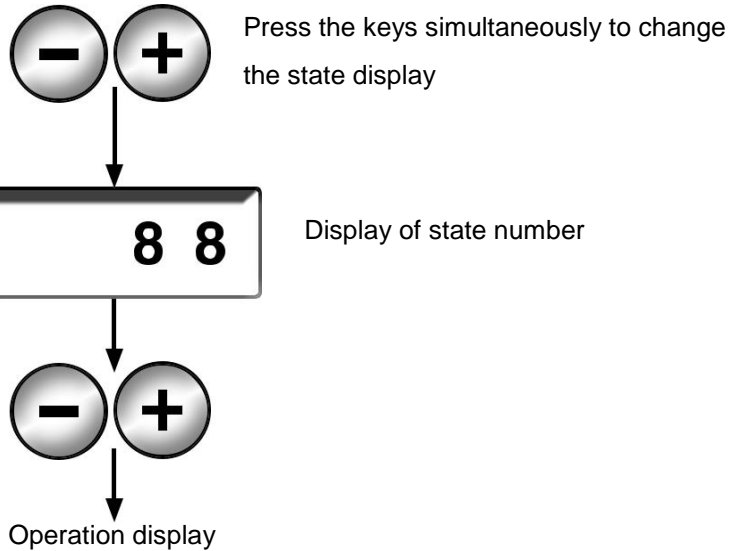



บริษัท เอดีดี เฟอร์เนส จำกัด

ADD FURNACE CO.,LTD.

44 ซอยบรมราชชนนี 70 ถนนบรมราชชนนี แขวงศาลาธรรมสพน์ เขตทวีวัฒนา กรุงเทพฯ 10170

โทร: 02-888-3472 โทร: ออกแบบ:08-08-170-170 แฟกซ์: 02-888-3258

<https://www.add-furnace.com> E-mail: sales@add-furnace.com

Operation display

Operation display / parameterisation and service box

► Display of the automatic system state during parameterisation or checking in the service box

b r n

Parameters are loaded from the parameterisation and service box into MPA

t S t

The MPA is in test mode initialised by the parameterisation and service box.
Note: The parameter and reset display is locked during the test



Info display

Info display
▶ The information display is activated out of the operation display (not during automatic parameter setting).
▶ The information display allows you to see the flame quality, the resettable runtime meter, the resettable start counter and the switching cycles counter.
▶ This mode is quit after 60 seconds due to a timeout if you do not press any key within this time period.

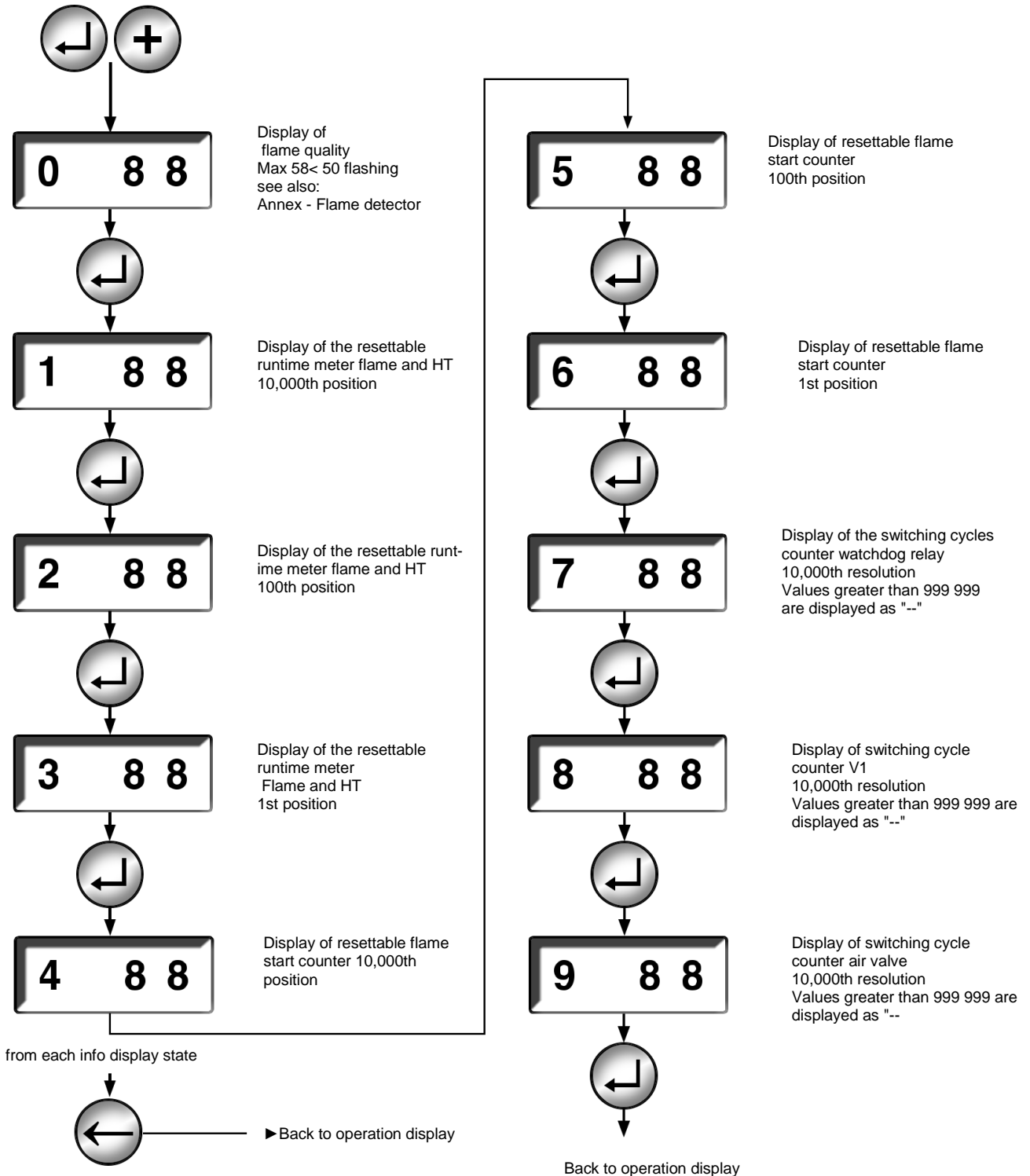



Error display

Error display
▶ An error message is automatically displayed as soon as the automatic system goes to the fault lock position.
▶ The last occurred error is displayed.
▶ F1 to F9 are also displayed in standby and operation. F5 to F9 can be acknowledged by pressing simultaneously

Automatic activation
if a fault is active

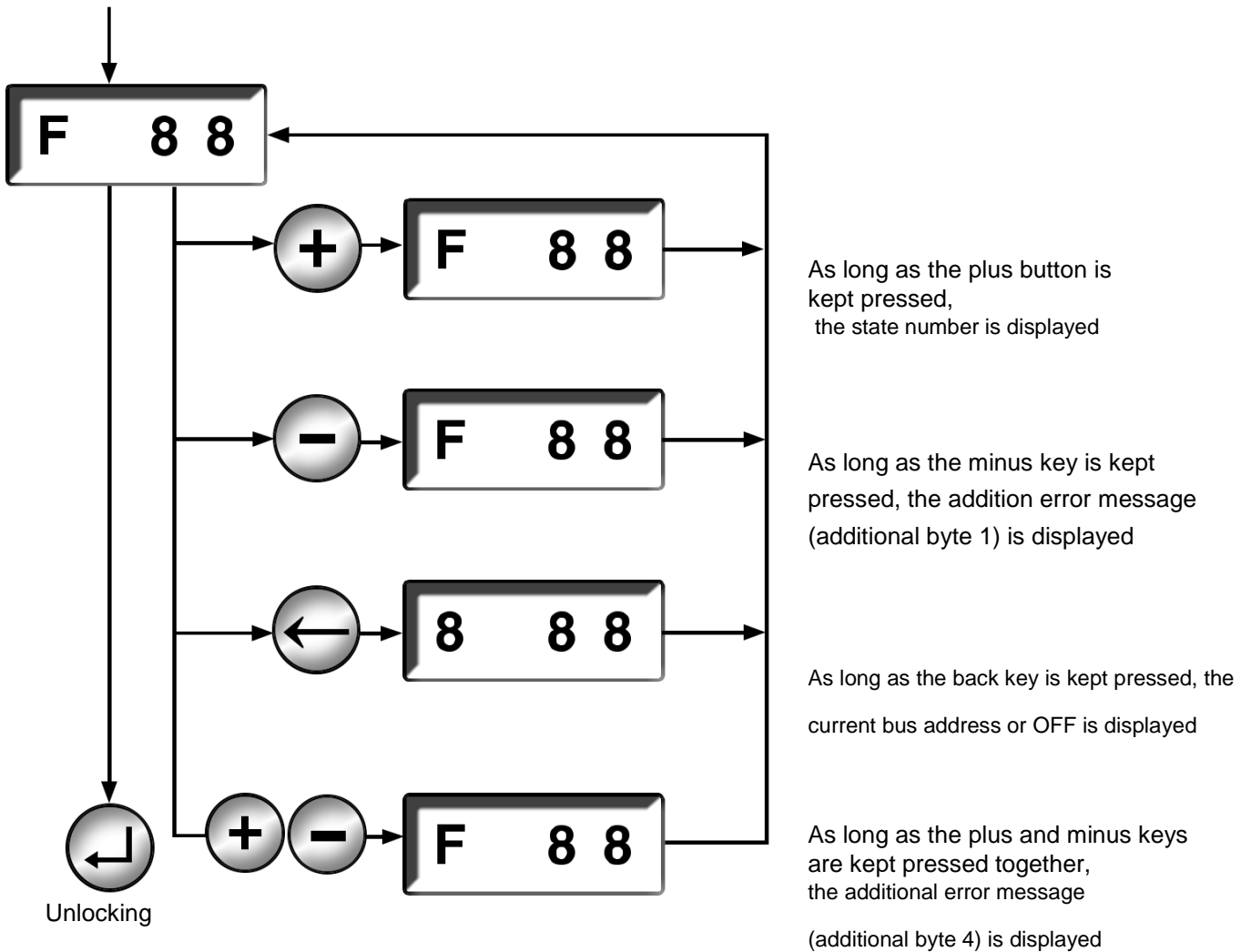



Display of the error memory

- Display of the error memory**
- ▶ The display of the error memory is used to call the last 10 errors.
 - ▶ The error that has occurred last is displayed.
 - ▶ The error memory display is activated out of the operation display (not during parameterisation display).
 - ▶ The error code is displayed on the two-digit seven-segment display.
 - ▶ This error memory display is quit after 60 s due to a timeout if you do not press any key within this time period.
 - ▶ If there is not any error for the error position, -- is displayed.

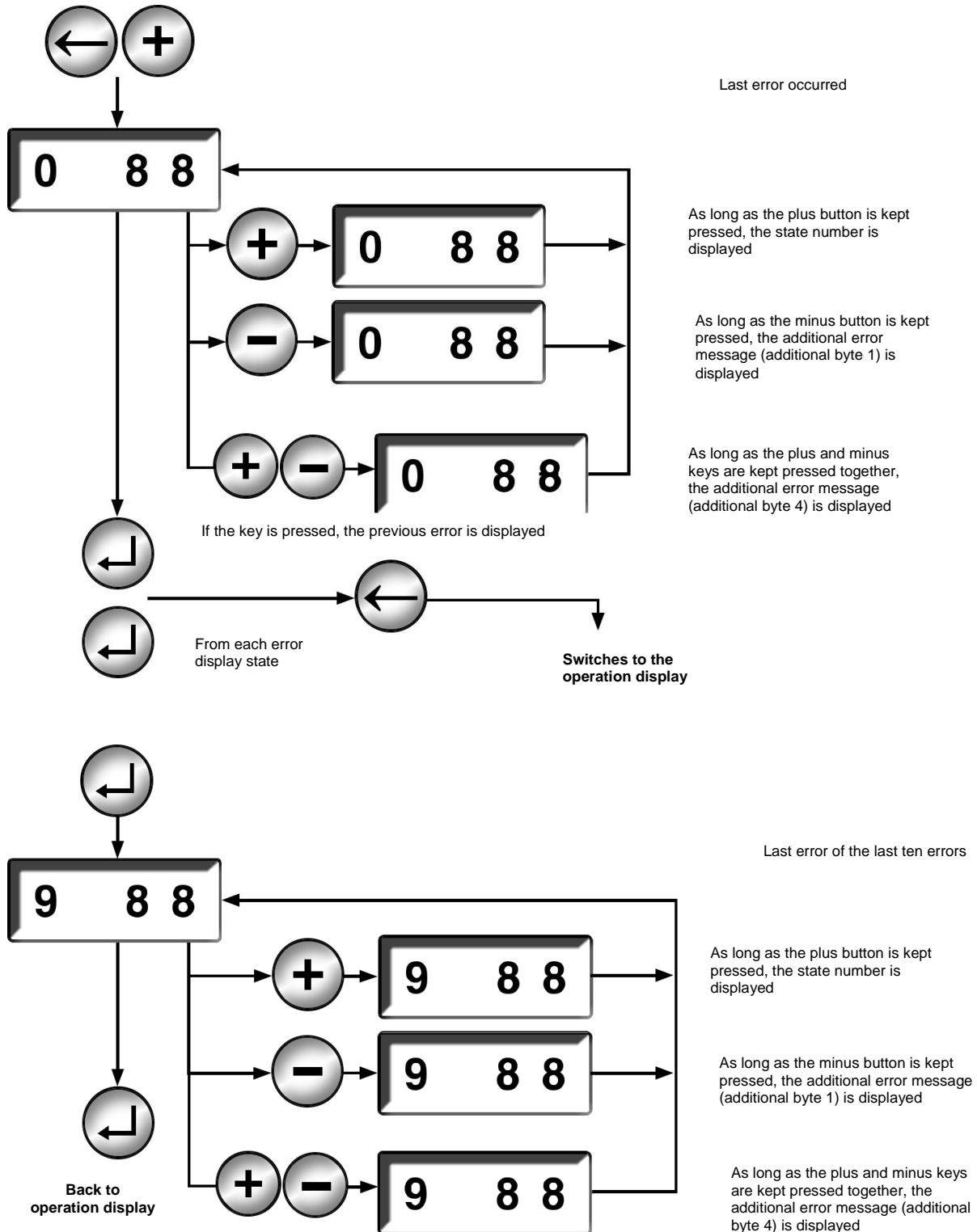

**Parameterisation display**

Parameterisation display
▶ After activating the automatic parameter setting, 19 parameter values must be defined; see parameter list
▶ This parameterisation is quit after 30 min. due to a timeout.
▶ A password is required for changing the parameters.
▶ Attention: Some parameter values are displayed in another resolution than in the parameterisation mode using VisionBox. If it is not possible to display the parameter value in the resolution, -- is displayed; nevertheless, the value may be changed in the resolution that can be displayed.
▶ To change service or OEM parameters, the required password or a higher-level password must be entered (e.g. all service parameters may also be changed using the OEM password)

Display number	Parameter	Value range	Unit
0	P30 - Duration pre-venting	0...99	1 s
1	P31 - Pre-ignition time	0...99	1 s
2	P32 - First safety time	1...15	1 s
3	P12 - Restart attempts	1...5	
4	P34 - Stabilisation time A	0...99	1 s
5	P83 - Duration of the switch-on delay after power on	0...99	1 s
6	P41 - Operation safety time FLW1	08...35 (=0.75...3.5 s)	0.1 s ^{*1}
7	P85 - Pre-venting time HT	0...99	1 s
8	P51 - Post-venting time flame	0...99	1 s
9	P14 - Restart attempts after a flameout	0...5	
A	P13 - Restart attempts after a missing flame	0...5	
b	P15 - Fault switch-off in case of opening the safety chain	0= Off / 1 = On	
C	P16 - LDW: Operating mode	0...99	
d	P18 - Operating mode X17	0...3	
E	P87 - Jump duration from flame or power On to HT	1...99	1 s
h	P17 - Temperature controller: Operating mode	0...4	
L	P19 - Operating mode output operation	0...99	
o	P52 - Off-period before restart flame	1...99	1 s
n ^{*2}	P11 - Fieldbus address	0...99 ^{*2}	

^{*1} Adjustable in increments:

08 = 0.75 s	12/16	(only possible for FLW1, smallest possible adjustment)
0P = 0.8125 s	13/16	
09 = 0.875 s	14/16	(for UV41 with 0.125 s reaction time)
10 = 1 s	16/16	
15 = 1.5 s	24/16	
18 = 1.8125 s	29/16	
19 = 1.875 s	30/16	(for UV41 with 0.125 s reaction time)
20 = 2 s	32/16	
25 = 2.5 s	40/16	
28 = 2.8125 s	45/16	
29 = 2.875 s	46/16	(for UV41 with 0.125 s reaction time)
30 = 3 s	48/16	
35 = 3.5 s	56/16	

^{*2} Use the shortcut - and + to switch between OFF (display = oF) and the address. Addresses over 99 must be set by means of VisionBox. Do not use address "0".



Parameterisation display

► Attention: Press the "Back" button to return to previous steps in the parameterisation mode.

Parameter switch to "Para", power supply "On"
Password entry

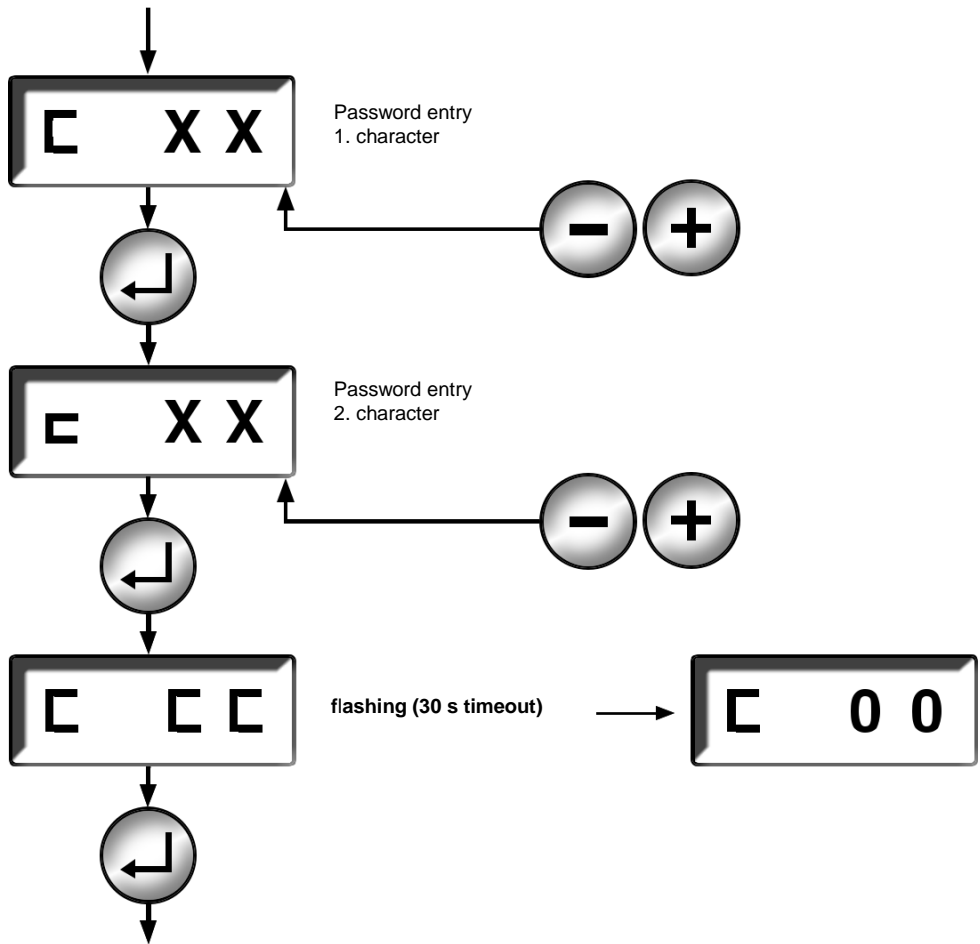

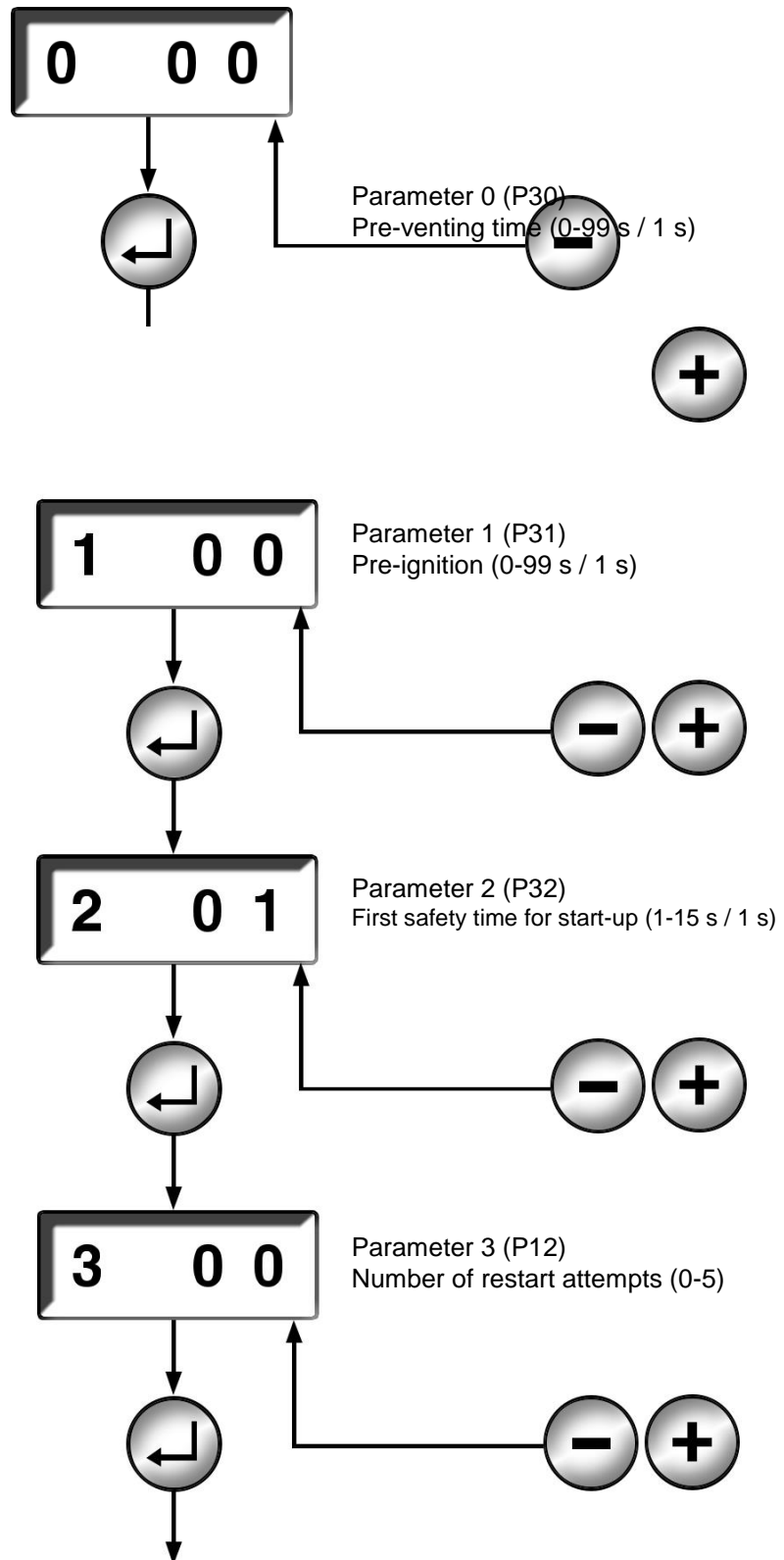

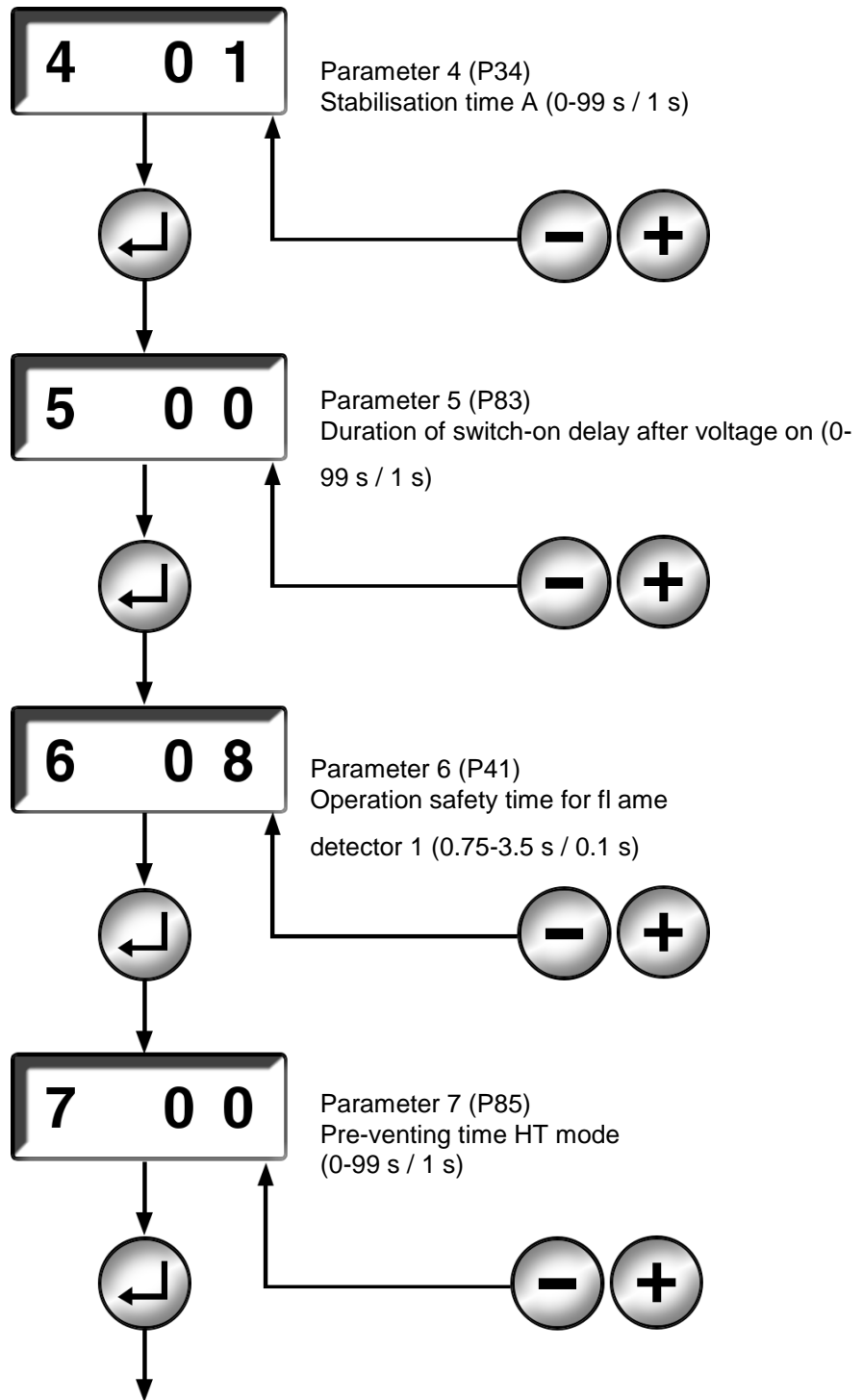

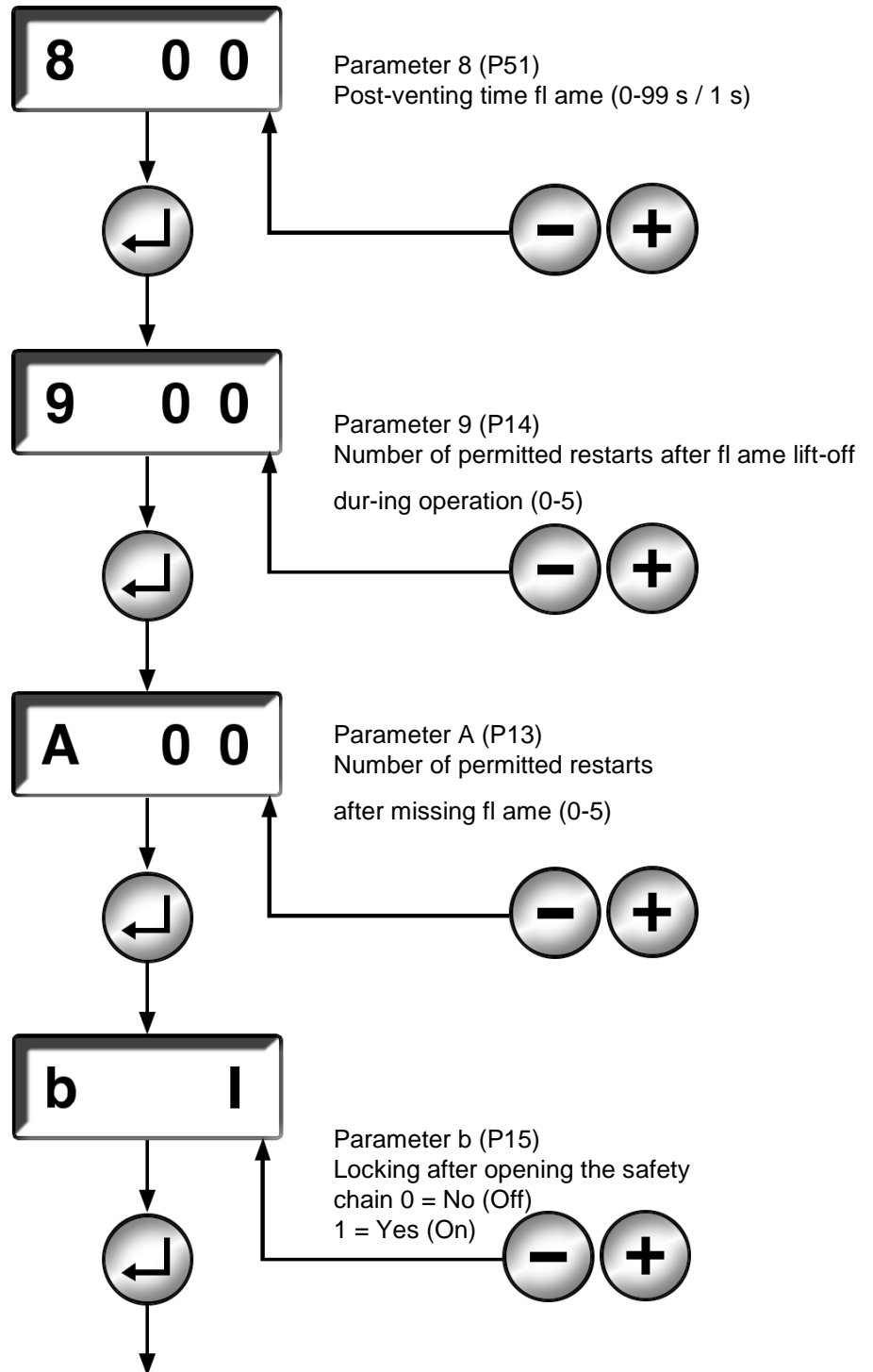

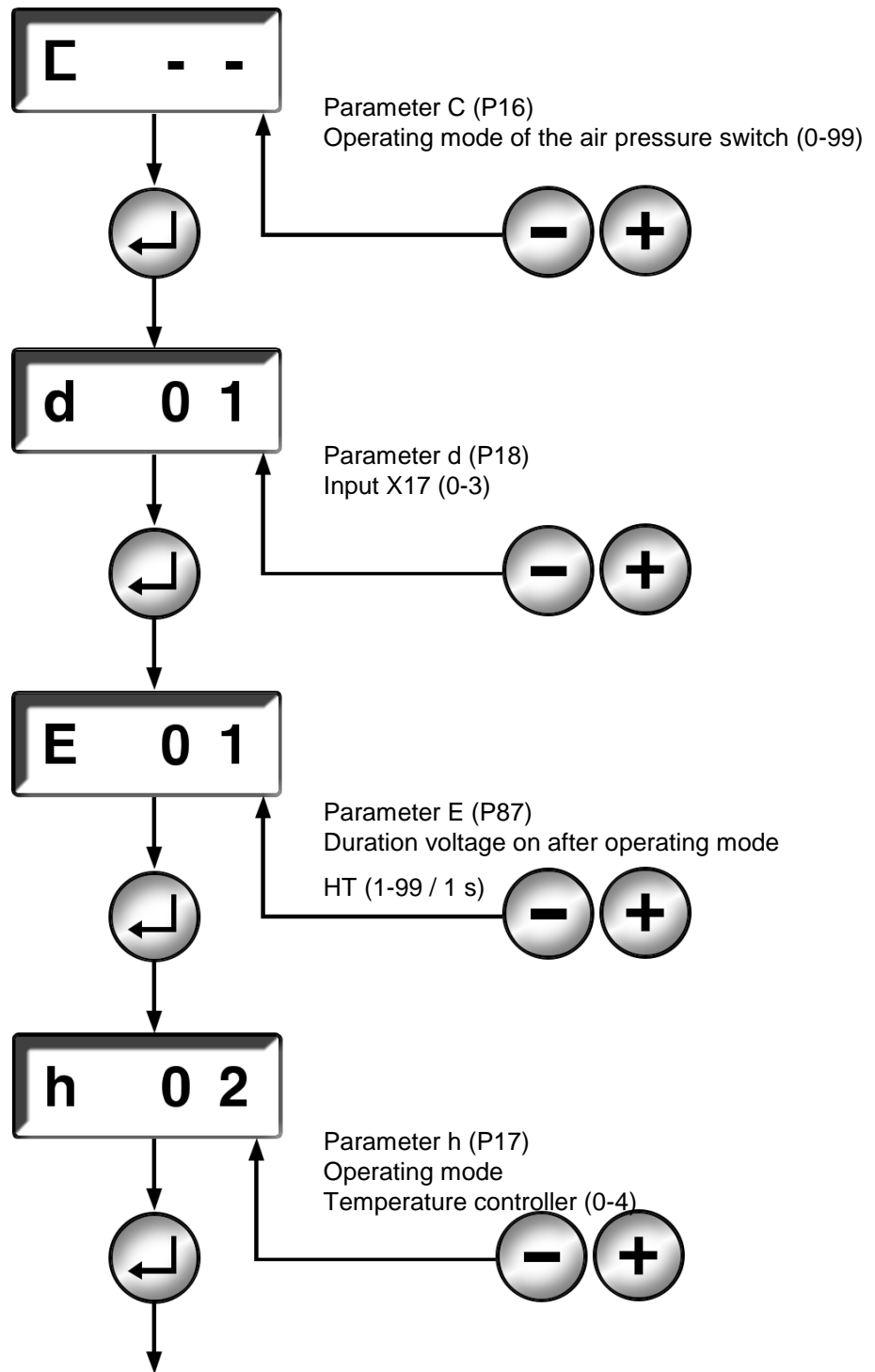

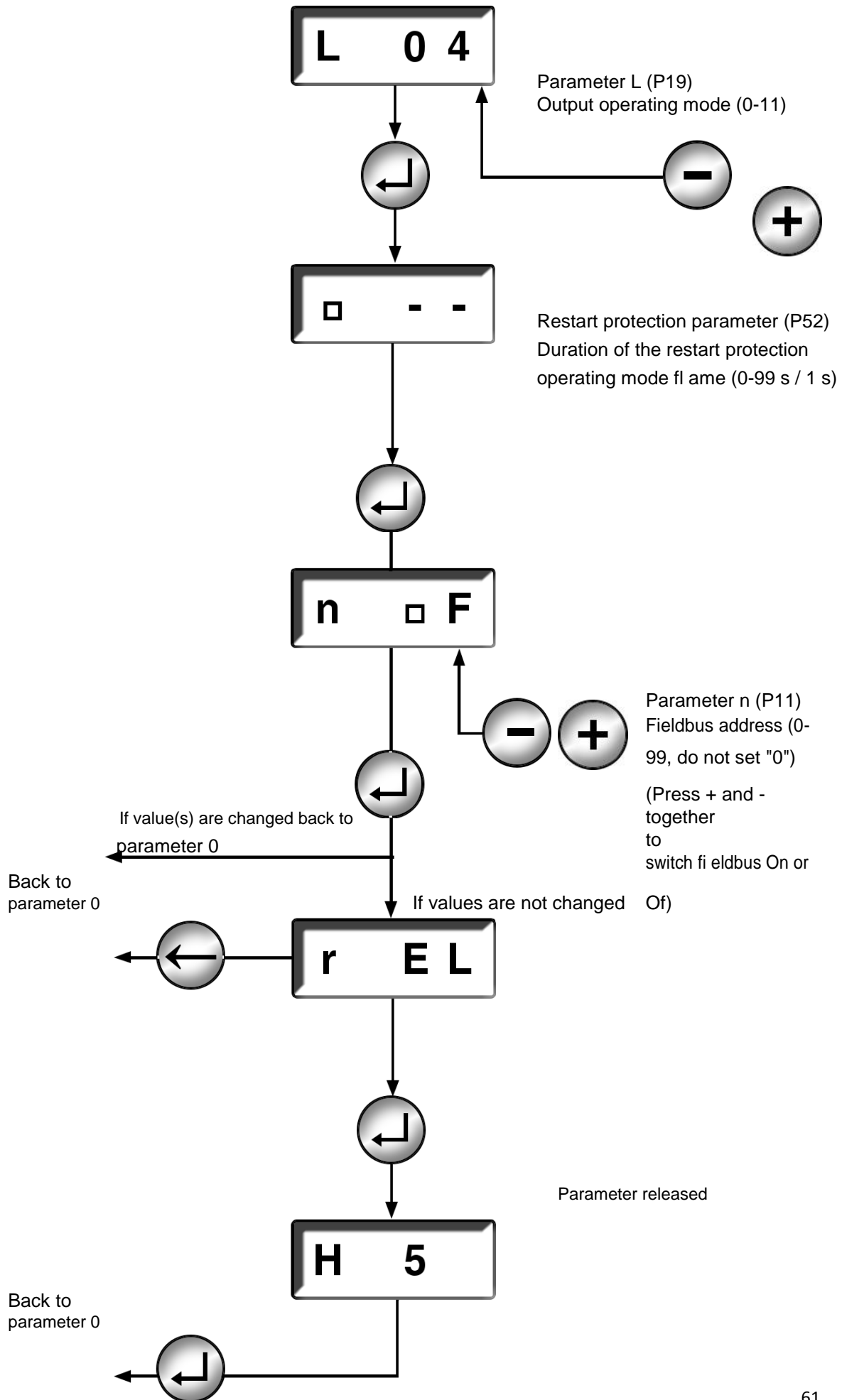



Reset display

Reset display

- ▶ The reset display is activated out of the operation display (not during automatic parameter setting).
- ▶ The reset display can be used to delete the error memory, the access level, the resettable runtime meter, the start counter or switching cycles counter and to change the passwords for the service and OEM level.
- ▶ This mode is quit after 60 seconds due to a timeout if you do not press any key within this time period.
- ▶ If the test mode of the parameter setting and service box is active, the reset display is locked.

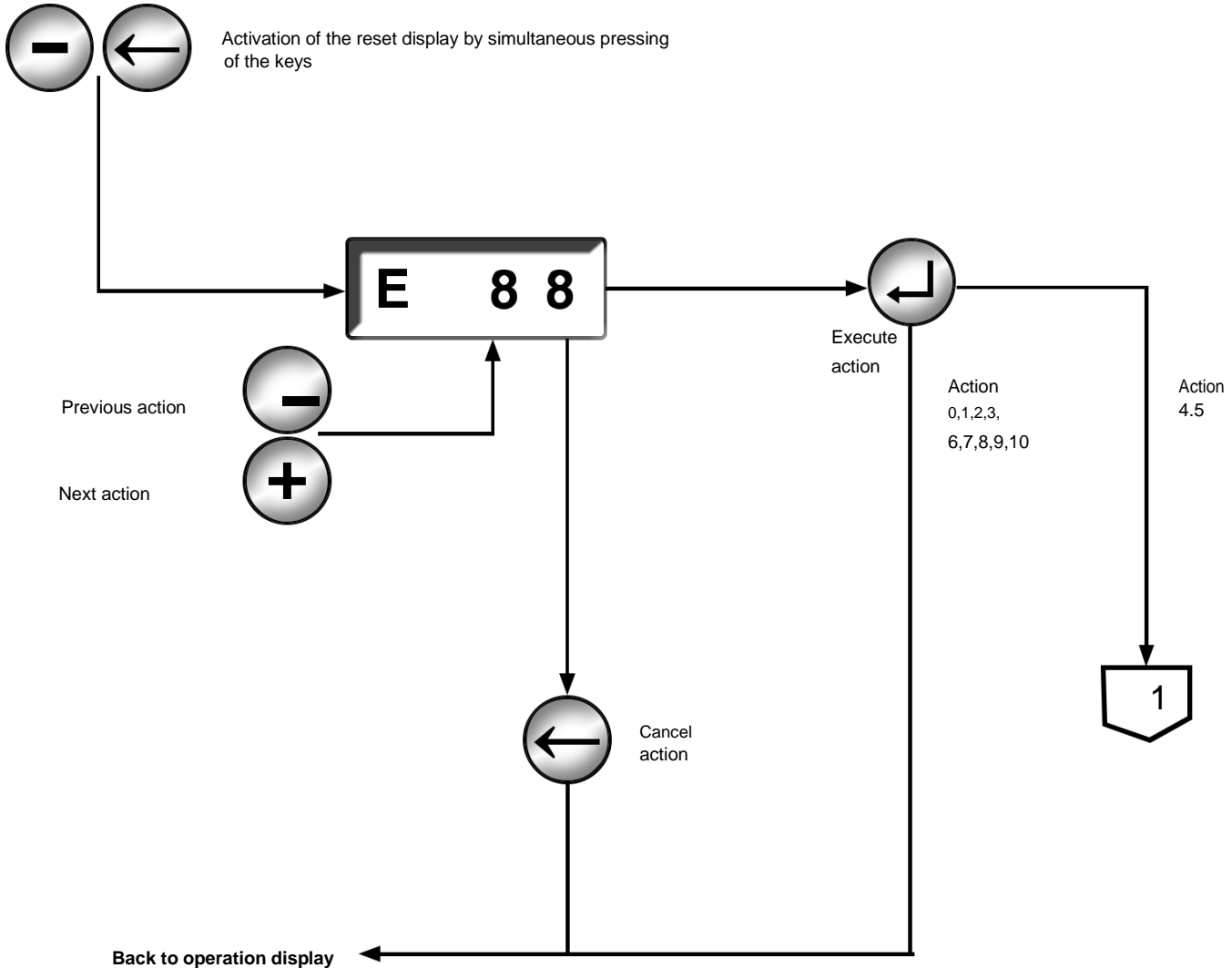

- Action to be carried out:
- 0 Delete the error memory
 - 1 Reset the access level
 - 2 Delete the resettable runtime meter flame and HT
 - 3 Delete resettable start counter
 - 4 Change password for service level
 - 5 Change password for OEM level
 - 6 Delete switching cycle counter Reset error F6
 - 7. Delete switching cycle counter V1 Reset error F7
 - 8. Delete switching cycle counter output air Reset error F8

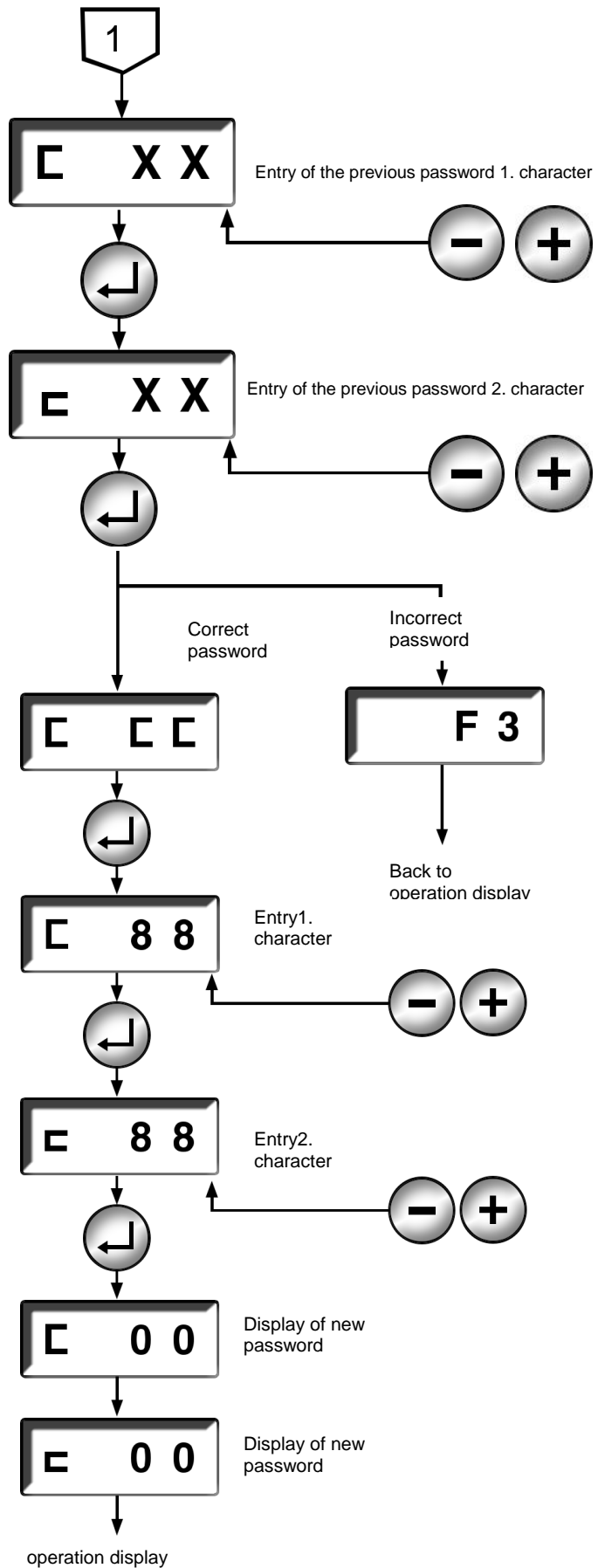



Error overview		
MPA 41xx PF errors without error ID		
Error ID	Internal error	Error description
Please see the tables above for more information about the individual errors.		
F1 flashing	x	Low voltage Internal error
F2 flashing	x	Internal error display
F3 flashing		The password has been entered incorrectly when trying to change it or has not been confirmed by means of the unlock key
F4 flashing		The signal of the remote unlocking via bus is active for too long
F5 flashing		Warning Flame has been detected in the HT mode and number of attempts to extinguish fire elapsed. The error message flashes three times every 5 s, alternatively to the state number (and possibly other error messages)
F6 flashing		Warning maintenance interval for the watchdog relay has elapsed. The error message flashes three times every 5 s, alternatively to the state number (and possibly other error messages)
F7 flashing		Warning maintenance interval for V1 elapsed. The error message flashes three times every 5 s, alternatively to the state number (and possibly other error messages)
F8 flashing		Warning maintenance interval for air valve elapsed. The error message flashes three times every 5 s, alternatively to the state number (and possibly other error messages)
F9 flashing		Connection to fieldbus missing. P11 was set to ON.



Error overview		
MPA 41xx PF		
Errors from the basic system (0x01 to 0x3F)		
Error ID	Internal error	Error description
0x01	x	
0x02	x	
0x03		INTERNAL ERROR: WATCHDOG Possible cause of the error: Too high ambient temperature Overvoltage
0x04		LOCK-OUT RELEASE DENIED Possible cause of the error: More than 5 unlocking operations in the last 15 minutes, remedy: Wait or carry out an extended unlocking
0x05	x	
0x06	x	
0x07	x	
0x08	x	
0x09	x	
0x0A	x	
0x0B	x	
0x0C	x	
0x0D	x	
0x0E	x	
0x0F	x	
0x10	x	
0x11		LOW VOLTAGE Possible cause of the error: The admissible lower voltage limit was not reached at least for a short time
0x12		POWER FAILURE Possible cause of the error: The supply voltage was interrupted during start-up, operation or regular switch-off
0x13		SAFETY CIRCUIT NOT POTENTIAL-FREE Safety chain not potential-free. Possible cause of the error: The fan continues running too long, remedy: Increase the time for the restart protection
0x14	x	
0x15	x	
0x16		COMMUNICATION TWI Possible cause of the error: VisionBox was connected to the TWI bus or separated from the bus while the MPA was not de-energised. The TWI line is subject to EMC interferences.
0x17	x	



Error overview		
MPA 41xx PF		
Error ID	Internal error	Error description
0x18		<p>ERROR FROM EXTERNAL APPLICATION</p> <p>Possible cause of the error: Timeout of parameter mode/manual mode (0.5 h without pressing a key) - detail error 4. Byte = 0xA0 An invalid fieldbus address has been entered in P11 for the connected bus module. Detail error 4. Byte = 0xA1 and 6. Byte = set address P11</p> <p>Additional byte 1: 0xB4 (error of the VisionBox) Switch-off was caused externally by selecting the "switch-off" function in the PC software of the VisionBox</p> <p>Additional byte 1: 0x90 (internal MPA error P2) Additional byte 4: 0x01 Internal error Additional byte 4: 0x08 Internal error Additional byte 4: 0x09 Internal error Additional byte 4: 0x0C Error configuration with 5. Byte=0x13: 6. Byte = parameter of allocation number, e.g. 0x13 = P19 7. Byte = parameter value of low byte 8. Byte = parameter value of high byte Error configuration with 5. Byte = 0x14: Heat request via HW input (P17=0) and air purge has priority over heat request (P241: Bit 0=1) not possible</p> <p>Additional byte 4: 0x16 Internal error Additional byte 4: 0x1D Internal error Additional byte 4: 0x1E Internal error Additional byte 4: 0xE8 Extension module not recognized Additional byte 4: 0xEE Interruption of communication to the MPA Additional byte 4: 0xEF Extension module not compatible with the MPA version Additional byte 4: 0xA0 Timeout parameterisation mode Additional byte 4: 0xA1 Invalid bus address Additional byte 4: 0xA2 Error parameter adjustment of the service box Additional byte 4: 0xA5 The extension module does not respond</p> <p>Additional byte 1 0xC2 (extension module error) Additional byte 4: 0x08 Internal error Additional byte 4: 0x09 Internal error Additional byte 4: 0x0A Internal error Additional byte 4: 0x1B Internal error</p>
0x19		reserved
0x1A	x	
0x1B		reserved
0x1C	x	
0x1D		<p>SYSTEM CRASHED</p> <p>Possible cause of the error: There is strong EMC interference on MPA</p>
0x1E	x	



Error overview		
MPA 41xx PF		
Errors from the extended functions (0x40 to 0x9F)		
Error ID	Internal error	Error description
0x40 - 0x42		reserved
0x43	x	
0x44 - 0x55		reserved
0x56	x	
0x57 - 0x58		reserved
0x59		INTERFACE P2 Possible cause of the error: The bus connection has been interrupted and the parameter P17 has been configured in a way that a bus interruption triggers a safety shutdown followed by a fault lock, see P17: Temperature controller operating mode
0x5A - 0x5F		reserved
0x60		CHANGE OF PARAMETER NOT RELEASED A monitored parameter has been changed
Errors from the application (from 0xA0)		
0xA0	x	STATE DURATION TOOLING Time in the parameterisation mode has elapsed
0xA1		reserved
0xA2		SAFETY CIRCUIT OPEN Possible cause of the error: The safety chain has been opened or is not closed The wires of the safety chain are interrupted
0xA3		reserved
0xA4	x	INTERNAL ERROR: FEEDBACK SIGNAL (V1)
0xA5	x	INTERNAL ERROR: FEEDBACK SIGNAL (V2)



Error overview		
MPA 41xx PF		
Errors from the application (from 0xA0)		
Error ID	Internal error	Error description
0xA6		EXTRANEIOUS LIGHT UPON STARTUP Possible cause of the error: Earth connection to an ionisation electrode Gas flows out and is burned for example by neighbouring burners Defective UV tube Connected flame detector (UV, ...) detects light or is defective
0xA7		NO FLAME DURING SAFETY PERIOD Additional information byte 0: Bit0=Flame on FLW1 Additional information byte 1: Flame quality for FLW1 Possible cause of the error: Ionisation electrode incorrectly set Ignition electrodes incorrectly set Insulated lines of the ignition electrodes or defective ionisation electrode Gas valves do not open the gas flow Connected flame detector (UV, ...) does not detect light or is defective Lines of mains connection on the MPA exchanged ("N" and "L1")
0xA8		FLAME FAILURE DURING OPERATION Additional information byte 0: Bit0=Flame on FLW1 Additional information byte 1: Flame quality for FLW1 Possible cause of the error: Flame body defective Connected flame detector (UV, ...) does not detect light or is defective
0xA9		FLAME FAILURE DURING STABILIZATION Additional information byte 0: Bit0=Flame on FLW1 Additional information byte 1: Flame quality for FLW1
0xAA		AIR PRESSURE SWITCH IS NOT IN "OFF" POSITION Possible cause of the error: The air pressure switch is defective There is air pressure during the idle state control, for example due to an air flow from the exhaust line,... The threshold value of the air pressure switch is set incorrectly
0xAB		AIR PRESSURE SWITCH FAILURE
0xAC	x	INTERNAL ERROR: FEEDBACK IGNITION
0xAD		LACK OF GAS PRESSURE SWITCH MIN.
0xAE- 0xAF		reserved
0xB0	x	
0xB1- 0xB5		reserved
0xB6		PROOF OF CLOSURE
0xB7-B9		reserved
0xBA		EXTRANEIOUS LIGHT UPON STARTUP External light > 1 min. after heat request
0xBB - 0xD1		reserved
0xD2		REMONTE RESET DENIED The MPA must be unlocked by means of the unlock key of the display
0xD3		HT SIGNAL OUT DI
0xD4	x	INTERNAL ERROR: FEEDBACK SR OUTPUT



บริษัท เอดีดี เฟอร์เนส จำกัด

ADD FURNACE CO.,LTD.

44 ซอยบรมราชชนนี 70 ถนนบรมราชชนนี แขวงศาลาธรรมสพน์ เขตทวีวัฒนา กรุงเทพฯ 10170

โทร: 02-888-3472 โทร: ออกแบบ:08-08-170-170 แฟกซ์: 02-888-3258

<https://www.add-furnace.com> E-mail: sales@add-furnace.com

Annex

Setting the bus address, bus termination	66-67
Profibus	68-72
Modbus	73-81
Flame detector	82-83
UV 41 (HE)	84-85
Ignition transformers	86-88
VisionBox	89



Setting the fieldbus address

If you want to connect the automatic system to the bus, a valid address must be entered in parameter P11. The display shows OFF during parameter setting if you have not set any address. Press the keys - and + to switch to the change mode. Now the desired address can be set.

If you want to change the address later on, it is possible during operation.

- Profibus 1 to 126
- Modbus 1 to 247

Attention: When changing the field address, the error F18 (0x18) may occur.

Important: Any modifications are applied after a restart or an extended unlocking of the automatic system. A bus connection is not required for operating the MPA. If a bus is not connected, the MPA can only receive a heat request via the hardware input "Temperature controller".

If there is a bus connection, which can be recognised by a flashing digit on the display, the heat request is given by means of bit 0 in AB0.

When the automatic system is disconnected from the bus again, the behaviour set in P17 is used: Temperature controller operating mode During operation and error messages, the current bus address may be seen by pressing the ← key.

If an invalid address for the connected bus module is set and the MPA is in automatic mode, it restarts (error 0x18).

If an invalid value for the connected bus module is set and the MPA is in parameter mode, an error message is generated.

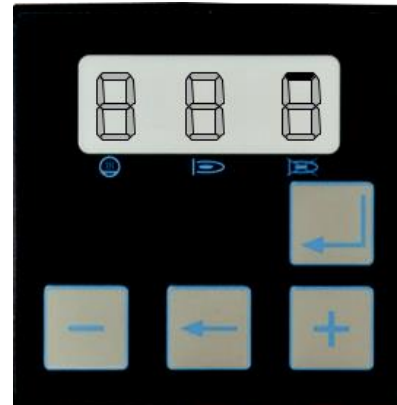

Bus termination

A terminator is required on the first and last device on the bus.

The shielding of the bus cable should be placed onto PE to avoid electromagnetic radiation.

Pin assignment MPA 4112

PF (M12-5 B-coded)

Pin assignment MPA 4122 PF

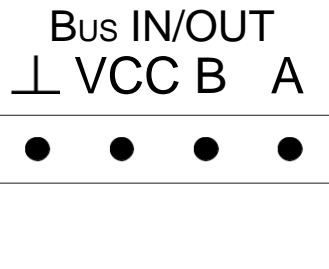
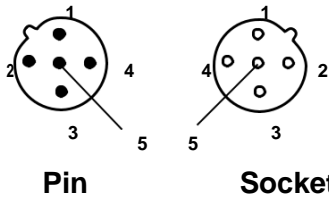

EM2/4 for MPA 41x

Pin no. MPA 4112 PF	Pin no. MPA 4122 PF	Signal
1	VCC	+5 V supply for bus termination
2	A	Data line minus (A conductor)
3		Earth
4	B	Data line plus (B conductor)
5	-	not used
Thread	-	Shielding (earth connection) recommended



**Extension module MPA 41xx EM 2/4
Profibus DP interface,
Modbus RTU / ASCII**

Universal extension module for integrating the MPA 41xx PF in fieldbus systems with up to 31 slaves (without repeater).

Integrated functions:
- Profibus DP interface
- Modbus RTU / ASCII

The bus protocol can be selected by means of the DIP switch.
Via the bus, commands can be transmitted to the MPA and status information can be queried.

BUS protocol preettings

The 4-pin DIP switch is used to select the bus protocol and to activate the respective line termination.
The bus protocol must be selected only with dead voltage. Modifications are impossible during operation.

Bus protocol selection

DIP switch No. 4:

OFF position = Profibus
ON position = Modbus

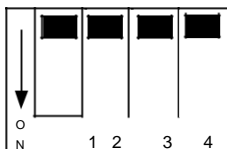

Bus termination

If the termination is activated via the DIP switch, external termination resistors must not be plugged into the output connectors.

If a termination is activated, the termination of the alternative bus protocol has to be deactivated in any case.

Modbus termination

DIP switch No. 1:

ON position = Modbus termination resistor 120 Ohm



**Profibus termination
Profibus termination**

DIP switches No. 2 and 3:

ON position = Profibus termination 220

Ohm. Important: Switch both of them

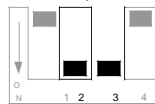

Setting the bus address

The bus address is entered in the P11 parameter (display indication "n"). OFF is displayed if no address has been entered.

An address between 1 and 99 (up to 126 via VisionBox) can be entered in the parameter mode. Any modifications will take effect only after a restart.

During operation and error messages, the current bus address may be seen by pressing the ← key.

Bus interruption

Modbus

The bus module requires at least one request per minute. If it is missing, the behaviour set in P17 is used

Profibus

If the cyclic data stream is interrupted, after a Profibus Watchdog period defined by the master (e.g. 2.5s) the behaviour set in P17 is used: Temperature controller operating mode

Profibus data

The amount of the input and output data is defined by the modules in the enclosed GSD file for Profibus.

Profibus output data master to MPA

The output data have 8 bits, see table

Bit	Output byte AB0
0	Heat request
1	Ventilation
2	Remote unlocking
3	Output X11 (P19=11)
4	Not used
5	Not used
6	Not used
7	Reserve (please set to 0)

Command contents of assigned bits:

Bit 0 (heat request) set to 1 by master = heat request.

Bit 1 If bit 1 (ventilation) is set to 1 by the master, the air valve is activated in the states 0 (error), 7 (flame: waiting for heat request) or state 26 (HT: waiting for heat request) (P241).

Bit 2 (remote unlocking) set to 1 by master (at least 0.5 s max. 5 s) = MPA is unlocked.

Bit 3 If bit 3 is set to 1 by master, the output X11 is switched on (P19=11).

Bit 4-6 not used

Bit 7 is reserved. Please set to 0

Eight modules are integrated in the delivered GSD file. Four, a module for Basic, Standard, Extended and Special Extended, do not receive an output byte but only input bytes (information about MPA, see below); however, they cannot give commands to MPA.



Profibus input data MPA to master

Input data is information about the state of the MPA. The input data contain a different number of bytes, depending on the data transfer module used. The lower bytes are always the same, i.e. Basic transfer is included in Standard transfer, Standard transfer in Extended transfer.

Basic transfer 2 bytes
EB0 and EB1

Standard transfer 4 bytes
EB0 to EB3

Extended transfer 12 bytes
EB0 to EB11

Special Extended transfer 20 bytes
EB0 to EB19

The bytes EB0 and EB1 contain bit information.

If the bit is set to 1, the condition is included in the description of the bits. Some bits are active during the fault (marked with "X"), others are 0.



Basic transfer area			
MPA 41xx PF			
Bit	Input byte EB0	Description	During fault
0	Flame input	X5	0
1	Input HT	X16	X
2	Input HT NC / Gas pressure switch / POC	X17	X
3	Warning flame in HT	Flame detected in the HT mode	X
4	Input Air pressure switch	X18	X
5	Input for temperature controller	X19	X
6	Output valve 1	X13	X
7	V2 boost / energy int. / HT active	X14	X
Bit	Input byte EB1	Description	During fault
0	Spark generator (ignition active)	X15	X
1	Warning switching cycles V1	Parameter value reached	0
2	Output air valve (air out)	X8	X
3	Output options	X11	X
4	Evaluation temperature controller (HW+bus)	Evaluation between temperature controller hardware input and bus specification	X
5	Warning switching cycles air valve	Parameter value reached	0
6	Warning switching cycles watchdog relay	Parameter value reached	0
7	Fault	X12	X



Standard transfer area			
MPA 41xx PF			
Bit	Input byte EB2	Description	During fault
0-7	State number or error code	Current state number or error code if there is a fault	X
Bit	Input byte EB3	Description	During fault
0-7	Flame quality	Quality of the flame via ionisation input	0

Extended transfer area			
MPA 41xx PF			
Bit	Input byte EB4	Description	During fault
0-7	Resettable runtime meter for flame and HT	Low byte (byte 0) of the 32-bit runtime meter (unit: s)	X
Bit	Input byte EB5	Description	During fault
0-7	Resettable runtime meter for flame and HT	Byte 1 of the 32-bit runtime meter (unit: s)	X
Bit	Input byte EB6	Description	During fault
0-7	Resettable runtime meter for flame and HT	Byte 2 of the 32-bit runtime meter (unit: s)	X
Bit	Input byte EB7	Description	During fault
0-7	Resettable runtime meter for flame and HT	High byte (byte 3) of the 32-bit runtime meter (unit: s)	X
Bit	Input byte EB8	Description	During fault
0-7	Resettable start counter for flame operation	Low byte (byte 0) of the 32-bit start counter	X
Bit	Input byte EB9	Description	During fault
0-7	Resettable start counter for flame operation	Byte 1 of the 32-bit start counter	X
Bit	Input byte EB10	Description	During fault
0-7	Resettable start counter for flame operation	Byte 2 of the 32-bit start counter	X
Bit	Input byte EB11	Description	During fault
0-7	Resettable start counter for flame operation	High byte (byte 3) of the 32-bit start counter	X



Special Extended transfer area			
MPA 41xx PF			
Bit	Input byte EB12	Description	During fault
0-7	Maintenance counter V1	Low byte (byte 0) of the 16-bit maintenance counter, Resolution 1000 switching cycles	X
Bit	Input byte EB13	Description	During fault
0-7	Maintenance counter V1	High byte (byte 1) of the 16-bit maintenance counter, Resolution 1000 switching cycles	X
Bit	Input byte EB14	Description	During fault
0-7	Maintenance counter Air valve	Low byte (byte 0) of the 16-bit maintenance counter, Resolution 1000 switching cycles	X
Bit	Input byte EB15	Description	During fault
0-7	Maintenance counter Air valve	High byte (byte 1) of the 16-bit maintenance counter, Resolution 1000 switching cycles	X
Bit	Input byte EB16	Description	During fault
0-7	Maintenance counter Watchdog relay	Low byte (byte 0) of the 16-bit maintenance counter, Resolution 1000 switching cycles	X
Bit	Input byte EB17	Description	During fault
0-7	Maintenance counter Watchdog relay	High byte (byte 1) of the 16-bit maintenance counter, Resolution 1000 switching cycles	X
Bit	Input byte EB18	Description	During fault
0-7	not used		0
Bit	Input byte EB19	Description	During fault
0-7	not used		0



Declaration of the Profibus interface	
MPA 41xx PF	
Manufacturer identification	ID number 0xOCF1 (Karl Dungs GmbH & Co. KG)
ASCIC type	VPC3+C
Sync and freeze mode	Is supported (Sync command: Freeze all outputs of the addressed slaves Freeze command: Freeze all inputs of the addressed slaves)
Cycle time	Maximum time until there is a response to a request telegram, depending on the bus transfer rate: 9.6 kBit/s to 500 kBit/s → 15 bit times 1500 kBit/s → 20 bit times 3000 kBit/s → 35 bit times 6000 kBit/s → 50 bit times 12000 kBit/s → 95 bit times
Diagnosis	The Profibus module creates an external diagnosis if it detects an internal error. The diagnosis information of the DP slave consists of standard diagnosis information (6 bytes). Octet 1: Bit 0 = Diagnosis station does not exist (sets master) Bit 1 = Diagnosis station not ready: The slave is not ready for data exchange. Bit 2 = Diag.cfg_Fault: Configuration data do not match Bit 3 = Diag.ext_diag: Slave has external diagnosis data Bit 4 = Diag.not supported: Requested function is not supported in slave Bit 5 = Diag.invalid_slave_response (sets slave fixed to 0) Bit 6 = Diag.prm_fault: Wrong parameters (ID number, etc.) Bit 7 = Diag.master_lock (sets master): Parameters of slave are set by another master Octet 2: Bit 0 = Diag.Prm_req: Slave requires new parameters Bit 1 = Diag.Stat_diag: Statical diagnosis (byte diag-bits) Bit 2 = fixed to 1 Bit 3 = Diag.WD_ON: Reaction monitoring active Bit 4 = Diag.freeze_mode: Freeze command received Bit 5 = Sync_mode: Sync command received Bit 6 = reserved Bit 7 = Diag.deactivated (sets master) Octet 3: Bit 0 - Bit 6 = reserved Bit 7 = Diag.ext_overflow Octet 4: Diag master_add: Master address after setting parameters (FF without parameter setting) Octet 5: High byte ID number Octet 6: Low byte ID number
Parameter	Only cyclical communication supported
Automatic baud rate detection	is supported



**Modbus data
Modbus RTU or ASCII mode**

The modbus protocol can be switched over to ASCII mode using the function code 0x41.

The setting is permanently saved in the slave.

Standard value (delivery) is modbus RTU, 19200 Band and Even Parity.

Modbus output data master to MPA

The output data are commands to the MPA. Use the following function codes to write these specifications.

05 (0x05) write Single Coil

06 (0x06) write Single Register

The output data have 16 bits, see table

Bit 3 If bit 3 is set to 1 by master, the output X11 is switched on (P19=11).

Bit 4-15 not used

Modbus input data MPA to master

Input data is information about the state of the MPA.

An EBx contains 16 bits.

Use the following function codes to read this information.

03 (0x03) Read Holding Registers

01 (0x01) Read Coils.

Bit	Register address 0
0	Heat request
1	Ventilation
2	Remote unlocking
3	Output terminal 11 (if P19 = 11)
4	Not used
5	Not used
6	Not used
7	Not used
8	Not used
9	Not used
10	Not used
11	Not used
12	Not used
13	Not used
14	Not used
15	Not used

Command contents of assigned bits:

Bit 0 (heat request) set to 1 by master = heat request.

Bit 1 If bit 1 (ventilation) is set to 1 by the master, the air valve is activated in the states 0 (error), 7 (flame: waiting for heat request) or state 26 (HT: waiting for heat request) (P241).

Bit 2 (remote unlocking) set to 1 by master (at least 0.5 s max. 5 s) = MPA is unlocked.



Bit	Register address 0	Description	During Fault
0	Flame input	X5	0
1	Input HT	X16	X
2	Input HT NC / Gas pressure switch / POC	X17	X
3	Warning flame in HT	Flame detected in the HT mode	X
4	Input Air pressure switch	X18	X
5	Input for temperature controller (HW)	X19	X
6	Output valve 1	X13	X
7	V2 boost / energy int. / HT active	X14	X
8...15	Not used		

Bit	Register address 1	Description	During Fault
0	Spark generator	X15 (ignition active)	X
1	Warning switching cycles V1	Parameter value reached	0
2	Output air valve (air out)	X8	X
3	Output options 0-11	X11	X
4	Evaluation temperature controller (HW+bus)	Evaluation between temperature controller hardware input and bus specification	X
5	Warning switching cycles air valve	Parameter value reached	0
6	Warning switching cycles watchdog relay	Parameter value reached	0
7	Fault	X12	X
8...15	Not used		

Bit	Register address 2	Description	During Fault
0-7	State number or error code	Current state number OR error code if there is a fault	X
8...15	Not used	Not used	

Bit	Register address 3	Description	During Fault
0-7	Flame quality	Quality of the flame signal/ionisation input	0
8...15	Not used	Not used	

Bit	Register address 4	Description	During Fault
0-7	Resettable runtime meter for flame and HT	Low byte (byte 0) of the 32-bit runtime meter (in s)	X
8...15	Not used	Not used	



Bit	Register address 5	Description	During Fault
0-7	Resettable runtime meter for flame and HT	Byte 1 of the 32-bit runtime meter (in s)	X
8...15	Not used	Not used	

Bit	Register address 6	Description	During Fault
0-7	Resettable runtime meter for flame and HT	Byte 2 of the 32-bit runtime meter (in s)	X
8...15	Not used	Not used	

Bit	Register address 7	Description	During Fault
0-7	Resettable runtime meter for flame and HT	High byte (byte 3) of the 32-bit runtime meter (in s)	X
8...15	Not used	Not used	

Bit	Register address 8	Description	During Fault
0-7	Resettable start counter for flame operation	Low byte (byte 0) of the 32-bit start counter	X
8...15	Not used	Not used	

Bit	Register address 9	Description	During Fault
0-7	Resettable start counter for flame operation	Byte 1 of the 32-bit start counter	X
8...15	Not used	Not used	

Bit	Register address 10	Description	During Fault
0-7	Resettable start counter for flame operation	Byte 2 of the 32-bit start counter	X
8...15	Not used	Not used	

Bit	Register address 11	Description	During Fault
0-7	Resettable start counter for flame operation	High byte (byte 3) of the 32-bit start counter	X
8...15	Not used	Not used	

Bit	Register address 12	Description	During Fault
0-7	Maintenance counter V1	Low byte (byte 0) of the 16-bit maintenance counter, Resolution 1000 switching cycles	X
8...15	Not used	Not used	

Bit	Register address 13	Description	During Fault
0-7	Maintenance counter V1	High byte (byte 1) of the 16-bit maintenance counter, Resolution 1000 switching cycles	X
8...15	Not used	Not used	

Bit	Register address 14	Description	During Fault
0-7	Maintenance counter air valve	Low byte (byte 0) of the 16-bit maintenance counter, Resolution 1000 switching cycles	X
8...15	Not used	Not used	



Bit	Register address 15	Description	During Fault
0-7	Maintenance counter air valve	High byte (byte 1) of the 16-bit maintenance counter,Resolution 1000 switching cycles	X
8...15	Not used	Not used	

Bit	Register address 16	Description	During Fault
0-7	Maintenance counter Watchdog relay	Low byte (byte 0) of the 16-bit maintenance counter,Resolution 1000 switching cycles	X
8...15	Not used	Not used	

Bit	Register address 17	Description	During Fault
0-7	Maintenance counter Watchdog relay	High byte (byte 1) of the 16-bit maintenance counter, Resolution 1000 switching cycles	X
8...15	Not used	Not used	

Bit	Register address 18	Description	During Fault
0-7	Not used	Not used	
8...15	Not used	Not used	

Bit	Register address 19	Description	During Fault
0-7	Not used	Not used	
8...15	Not used	Not used	

Bit	Register address 20	Description	During Fault
0-7	Additional error information	First info byte of additional error	x
8...15	Not used	Not used	

In the following, the information is summarised to allow complete use of the 16-bit register. Query if the bus load is to be reduced

Bit	Register address 20	Description	During Fault
0	Flame input	X5	0
1	Input HT	X16	x
2	Input HT NC / Gas pressure switch / POC	X17	x
3	Warning flame in HT	Flame detected in the HT mode	x
4	Input air pressure switch	X18	x
5	Input for temperature controller	X19	x
6	Output valve 1	X13	x
7	V2 boost / energy int. / HT active	X14	x
8	Spark generator	X15 (ignition active)	x
9	Warning switching cycles V1	Parameter value reached	0
10	Output air valve (air out)	X8	x
11	Output options 0-11	X11	x
12	Evaluation temperature control-ler (HW + bus)	Evaluation between temperature controller hardware input and bus specification	x
13	Warning switching cycles air valve	Parameter value reached	0
14	Warning switching cycles watchdog relay	Parameter value reached	0
15	Fault	X12	x



บริษัท เอดีดี เฟอร์เนส จำกัด

ADD FURNACE CO.,LTD.

44 ซอยบรมราชชนนี 70 ถนนบรมราชชนนี แขวงศาลาธรรมสพน์ เขตทวีวัฒนา กรุงเทพฯ 10170

โทร: 02-888-3472 โทร: ออกแบบ:08-08-170-170 แฟกซ์: 02-888-3258

<https://www.add-furnace.com> E-mail: sales@add-furnace.com

Bit	Register address 22	Description	During Fault
0-7	State number or Error code	Current state number OR error code if there is a fault	X
8-15	Flame quality	Quality of the flame via ionisation input	0

Bit	Register address 23	Description	During Fault
0-7	Resettable Runtime meter for flame and HT	Low byte (byte 0) of the 32-bit runtime meter (in s)	X
8-15	Resettable Runtime meter for flame and HT	Byte 1 of the 32-bit runtime meter (in s)	X

Bit	Register address 24	Description	During Fault
0-7	Resettable Runtime meter for flame and HT	Byte 2 of the 32-bit runtime meter (in s)	X
8-15	Resettable Runtime meter for flame and HT	High byte (byte 3) of the 32-bit runtime meter (in s)	X

Bit	Register address 25	Description	During Fault
0-7	Resettable start counter for flame operation	Low byte (byte 0) of the 32-bit start counter	X
8-15	Resettable start counter for flame operation	Byte 1 of the 32-bit start counter	X



Bit	Register address 26	Description	During Fault
0-7	Resettable start counter for flame operation	Byte 2 of the 32-bit start counter	X
8...15	Resettable start counter for flame operation	High byte (byte 3) of the 32-bit start counter	X

Bit	Register address 27	Description	During Fault
0-15	Maintenance counter V1	16-bit maintenance counter, resolution 1000 switching cycles	X

Bit	Register address 28	Description	During Fault
0-15	Maintenance counter air valve	16-bit maintenance counter, resolution 1000 switching cycles	X

Bit	Register address 29	Description	During Fault
0-15	Maintenance counter Watchdog relay	16-bit maintenance counter, resolution 1000 switching cycles	X

Bit	Register address 30	Description	During Fault
0-15	not used		

Bit	Register address 31	Description	During Fault
0-7	Additional error information	1. Detailed information on the error message	X
8...15	Not used	Not used	

Bit	Register address 32	Description	During Fault
0-7	Article number SW P1	Byte 0 (low byte) of the 24-bit article number	X
8...15	Article number SW P1	Byte 1 of the 24-bit article number	x

Bit	Register address 33	Description	During Fault
0-7	Article number SW P1	Byte 0 (high byte) of the 24-bit article number	X
8...15	Index article number SW P1	e.g. 0x5F="_"; 0x41="A", 0x42="B" ...	X

Bit	Register address 34	Description	During Fault
0-7	Day of production	of MPA41xxPF	X
8...15	Month of production	of MPA41xxPF	X

Bit	Register address 35	Description	During Fault
0-7	Year of production	of MPA41xxPF	X
8...15	Not used		

Bit	Register address 36	Description	During Fault
0-7	Device number	Byte 0 (low byte) of the 32-bit device number	X
8...15	Device number	Byte 1 of the 32-bit device number	X

Bit	Register address 37	Description	During Fault
0-7	Device number	Byte 2 of the 32-bit device number	X
8...15	Device number	Byte 3 (high byte) of the 32-bit device number	X



Bit	Register address 38	Description	During Fault
0-7	Article number HW	Byte 0 (low byte) of the 24-bit article number	X
8...15	Article number HW	Byte 1 of the 24-bit article number	x

Bit	Register address 39	Description	During Fault
0-7	Article number HW	Byte 2 (high byte) of the 24-bit article number	X
8...15	Index article number HW	e.g. 0x5F=" _"; 0x41="A", 0x42="B" ...	x

Bit	Register address 40	Description	During Fault
0-7	Article number device	Byte 0 (low byte) of the 24-bit article number	X
8...15	Article number device	Byte 1 of the 24-bit article number	x

Bit	Register address 41	Description	During Fault
0-7	Article number device	Byte 2 (high byte) of the 24-bit article number	X
8...15	Index article number device	e.g. 0x5F=" _"; 0x41="A", 0x42="B" ..	x

Bit	Register address 42	Description	During Fault
0-7	Article number SW EM	Byte 0 (low byte) of the 24-bit article number	X
8...15	Article number SW EM	Byte 1 of the 24-bit article number	x

Bit	Register address 43	Description	During Fault
0-7	Article number SW EM	Byte 2 (high byte) of the 24-bit article number	X
8...15	Article number SW EM	e.g. 0x5F=" _"; 0x41="A", 0x42="B" ...	x

Bit	Register address 44	Description	During Fault
0-7	Day of production	of EM 2/4	X
8...15	Month of production	of EM 2/4	x

Bit	Register address 45	Description	During Fault
0-7	Year of production EM	of EM 2/4	X
8...15	Not used		

Bit	Register address 46	Description	During Fault
0-7	Device number EM	Byte 0 (low byte) of the 32-bit device number	X
8...15	Device number EM	Byte 1 of the 32-bit device number	

Bit	Register address 47	Description	During Fault
0-7	Device number EM	Byte 2 of the 32-bit device number	X
8...15	Device number EM	Byte 3 (high byte) of the 32-bit device number	x

Bit	Register address 48	Description	During Fault
0-7	Article number HW-EM	Byte 0 (low byte) of the 24-bit article number	X
8...15	Article number HW-EM	Byte 1 of the 24-bit article number	x



Bit	Register address 49	Description	During Fault
0-7	Article number HW-EM	Byte 2 (high byte) of the 24-bit article number	X
8...15	Index article number HW-EM	e.g. 0x5F=" _"; 0x41="A", 0x42="B" ...	x

Bit	Register address 50	Description	During Fault
0-7	Article number device EM	Byte 0 (low byte) of the 24-bit article number	X
8...15	Article number device EM	Byte 1 of the 24-bit article number	x

Bit	Register address 51	Description	During Fault
0-7	Article number device EM	Byte 2 (high byte) of the 24-bit article number	X
8...15	Index article number device EM	e.g. 0x5F=" _"; 0x41="A", 0x42="B" ...	x

Bit	Register address 52	Description	During Fault
0-7	Additional error information	4. Detailed information on the error message	X
8...15	Not used		



Line lengths

Designation	Line length	Electrical data
Profibus DP	Max. 1200 m	Galvanically isolated 4kV
Modbus	Max. 1000 m	Galvanically isolated 4kV

Supported baud rates

Profibus

The following table is only valid for line type A to EN 50170

Transfer speed kBit/s	9.6	19.2	45.45	93.75	187.5	500	1500	3000	6000	12000
max. line length in m	1200	1200	1200	1200	1000	400	200	100	100	100

Modbus

9600 bauds, 19200 bauds,
19200 bauds and 57600 bauds

The baud rate can be changed during operation by means of the function code 0x41 and is permanently saved in the slave. The relative parity bit can also be defined. None, Even and Odd are supported.

Default values (upon delivery) are

19200 bauds and Even Parity.

Bus termination

A termination resistor is required on the first and the last device of the bus structure.

Alternatively to internal termination (see above), an external bus termination resistor can be connected instead of another bus cable.

The bus cable shielding is to be connected to PE to avoid electromagnetic radiation.

Pin assignment MPA 4112 PF (M12-5 B-coded)

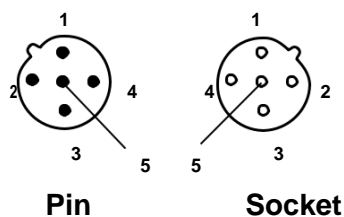

Pin assignment MPA 4122 PF

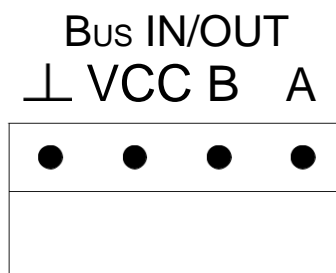

Pin no. MPA 4112 PF	Pin no. MPA 4112 PF	Signal
1	VCC	+5 V supply for bus termination
2	A	Data line minus (A conductor)
3		Earth
4	B	Data line plus (B conductor)
5	-	not used
Thread	-	Shielding (earth connection) recommended



Flame detector

Operation requirements of separate flame detectors on the MPA 41xx PF:

The flame detectors must be tested and approved for monitoring gas burn-ers.

The **reaction times** must be ob-served!

Total reaction time = reaction time MPA + reaction time flame detector. A proof about the compliance with the requirements of EN 298 is required.

The reaction time after a flame lift-off of an external flame detector may not be longer than the start-gas safety time. When connected to FLW1, the ionisation behaviour of a flame must be simulated (rectifier effect). The following values are active on the ionisation input and output of the MPA:

230 VAC +10 % -15 %.

The internal resistance of the MPA is approx 1 MΩ. For safety reasons, the flame sensor must work properly also with an internal resistance of 360 kΩ.

Under these conditions, the simulation circuit in the flame detector must reach at least a direct current 3 μA.

If an alternating current with a DC component is simulated, the DC component should not drop below 25 %.

The current can be derived to N, PE or returned to N on the MPA.

The EMC regulations must be observed (EN 298). The entire system must not produce inadmissible emis-sions.

MPA 41xx PF is not galvanically iso-lated.

MPA 41xx PF and the flame detector must be connected according to the correct phase.

Attention

DUNGS cannot be held liable if the flame detector and the automatic burn-er control system do not work orderly together. Especially if the electromag-netic behaviour is not according to the regulations or if the time-dependent behaviour is not correct.

The quality of the flame signal is displayed for flame detector 1 as a number between 0 and 58.

Evaluation of the flame signal is only possible with ionisation flame monitor-ing and monitoring with UV41 (HE).

ION vs. digits MPA41

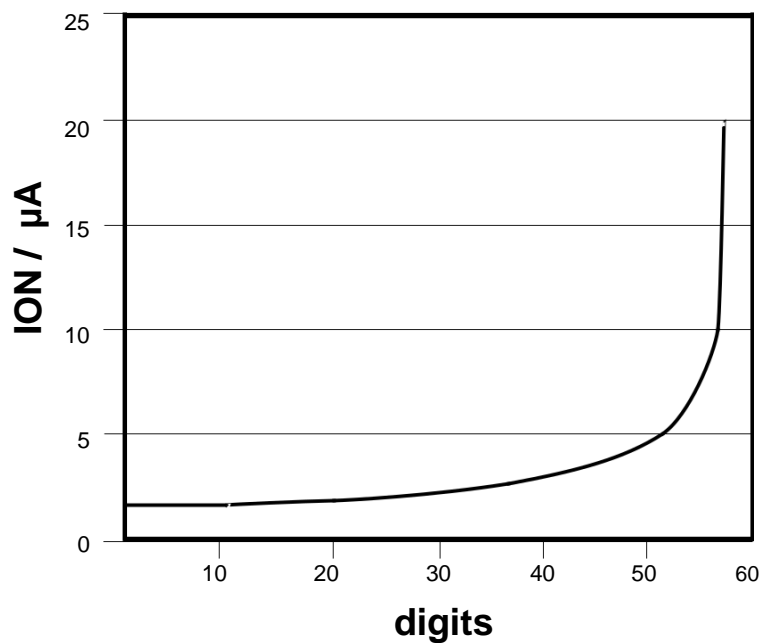



บริษัท เอดีดี เฟอร์เนส จำกัด

ADD FURNACE CO.,LTD.

44 ซอยบรมราชชนนี 70 ถนนบรมราชชนนี แขวงศาลาธรรมสพน์ เขตทวีวัฒนา กรุงเทพฯ 10170

โทร: 02-888-3472 โทร: ออกแบบ:08-08-170-170 แฟกซ์: 02-888-3258

<https://www.add-furnace.com> E-mail: sales@add-furnace.com

Flame detectors released by DUNGS:

Manufac-turer	Designa-tion	Type	Output signal	Safety time Flame de-tector	Total reac-tion time after flame lift-off	Intermittent	Continu-ous operation
-	Ionisation electrode	Ionisation	Ionisation	0 s	P41	Yes	No
DUNGS	UV41 (HE)	UV tube	Ionisation	0.125 s (= 2/16 s)	P41 + 0.125 s	Yes	No

Flame detectors that are not included in this list must be authorised before use by DUNGS.



UV 41 (HE)

The UV 41 (HE) is a flame detector with UV tube in metal design for high mechanical stress.

The flame detector is connected to the ionisation input of the MPA 41xx PF and is suitable for intermittent operation.

The adapter UV4x-EM1/x must be used for mounting the UV 41 (HE).



Technical data

UV 41 General	
Rated voltage	230 VAC -15 %...+10 %
Frequency	50...60 Hz
Power consumption	< 1 W
Protection type	IP54
Ambient temperature	-40 °C ... +60 °C -40 °C ... +80 °C with reduced lifetime of the UV tube
Storage and transport	-40 °C ... +80 °C
Humidity	DIN 60730-1, no dewing admissible
Lifetime	10,000 operating hours (design (HE) reduced lifetime)
Mounting position	as desired
Dimensions in mm	Diameter: 44.5 mm Length: 94 mm Length with UV4x-EM1: approx. 128-143 mm
Max. line length	10 m

Dimensions

UV 41 (HE)

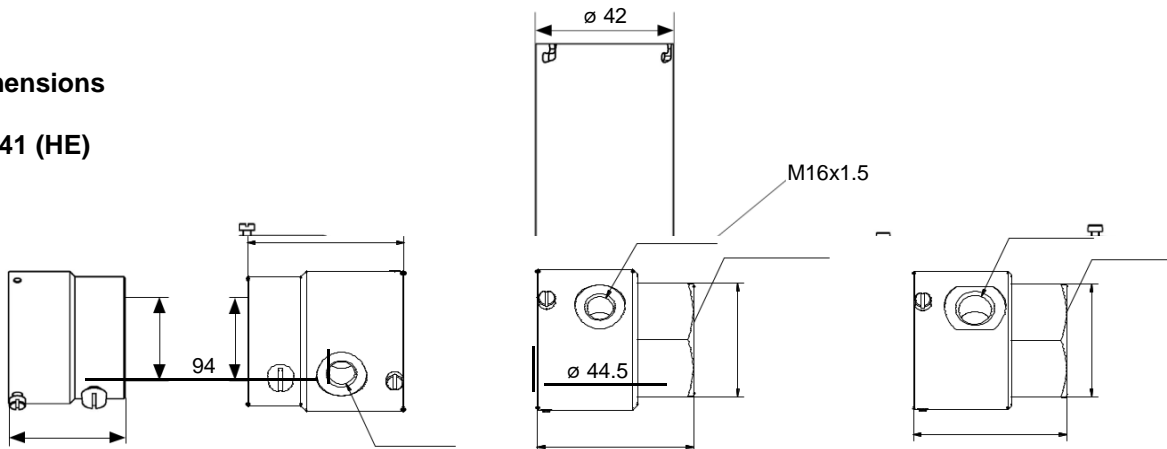

UV 4x EM 1/x Adapter

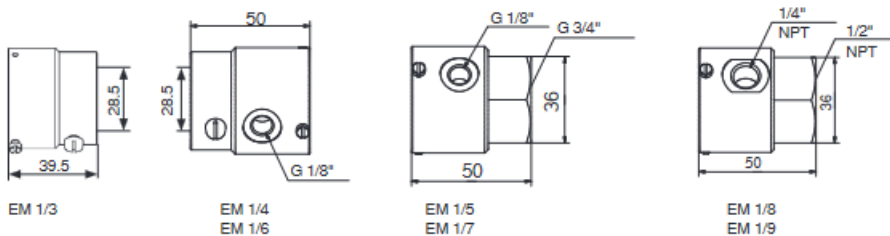



Mounting

The UV 41 (HE) must be mounted as closely as possible to the flame to be monitored.

For mounting the UV41 on the burner a suitable EM1/x adaptor is required. When mounting it, make sure that the rubber sealing ring enclosed with the UV 41 (HE) is inserted between the UV 41 (HE) and the mounting adapter. The UV 41 (HE) sensor will also detect external light as a flame, which is why the UV 41 (HE) must be mounted such that, for example, no daylight, ignition sparks or UV sources can be detected. The UV 41 (HE) tube is sensitive to impacts, vibrations, etc., which is why it must be mounted without vibrating it. After the mounting work is complete, all screws must be checked for tight fit. If temperatures of more than 60 °C are reached at the UV 41 (HE), an adapter fitted with a quartz cover glass and, if necessary, an additional purging air connection must be used (upon request).

Attention

The maximum allowed line lengths must not be exceeded. Supply and signal lines must be laid separately, as far as possible.

Attention

The flame detector UV 41 (HE) is delivered without cable screw connection. To guarantee the required traction relief and IP protection class IP 54, a cable screw connection M16x1.5 for cable diameters 5 - 9 mm is required (3 x 0.75 mm², which corresponds to an AWG of 20, to 3 x 1.5 mm², which corresponds to an AWG of 16). The protective earth conductor must be connected using an insulated female connector according to DIN 46245.

Electrical connection

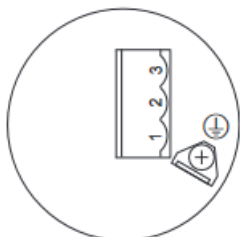

Connection	UV 41 (HE)	MPA 41xx
Pin 1	Out	Ionisation (5)
Pin 2	N	N
Pin 3	L	Vers. FLW (7)
PE	⏚	⏚



บริษัท เอดีดี เฟอร์เนส จำกัด

ADD FURNACE CO.,LTD.

44 ซอยบรมราชชนนี 70 ถนนบรมราชชนนี แขวงศาลาธรรมสพน์ เขตทวีวัฒนา กรุงเทพฯ 10170

โทร: 02-888-3472 โทร: ออกแบบ:08-08-170-170 แฟกซ์: 02-888-3258

<https://www.add-furnace.com> E-mail: sales@add-furnace.com

DEZ ignition transformers

Technical description

The DUNGS DEZ are electronic high-performance ignition transformers with high-frequency oscillation technology. Compared with conventional inductive ignition transformers, the DEZ are much smaller and lighter.

Designs for one or two ignition electrodes are available in different voltage versions.

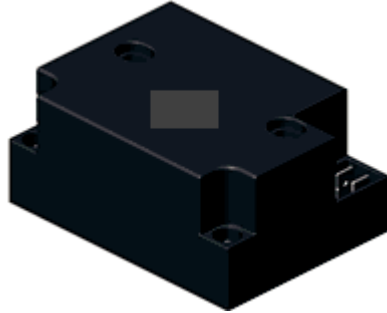

Application

For oil and gas burners, ignition takes place, depending on design, with one ignition electrode against the burner mass or with two ignition electrodes between the electrodes.

Approval

73/23/EEC Low-Voltage Directive
89/336/EEC EMC Directive



DEZ function

The DEZ ignition transformers are available in two versions. Either with a high-voltage output (DEZ 1xx) for ignition against the burner mass or with two high-voltage outputs (DEZ 2xx) for ignition between the electrodes.

Both versions are available with different performance data.

For use in burner systems in which ignition and ionisation flame monitoring takes place via a common electrode, the "SEO" versions must be used.

DEZ 1xx

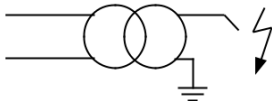

DEZ 2xx

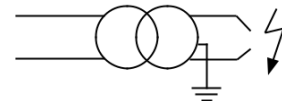

DEZ Versions	DEZ 100	DEZ 101	DEZ 100 SEO	DEZ 101 SEO	DEZ 200
High-voltage outputs	1	1	1	1	2
Mains voltage [VAC]	230/240	120	230	120	230/240
Frequency [Hz]	50/60	50/60	50/60	50/60	50/60
Current consumption [A]	0.3	0.5	0.3	0.5	0.14
Power consumption [VA]	69	55	69	60	32
Secondary voltage [kV] +/- 10 %	1 x 15	1 x 15	1 x 15	1 x 15	2 x 10
Secondary frequency [kHz]	10	13	10	16	10
Short-circuit current [mA]	30	30	30	30	20
Duty cycle 3 min.	33 %	33 %	33 %	33 %	100 %
Protection type	IP 54	IP 54	IP 54	IP 54	IP 54
Ambient temperature ta [°C]	-20...60 °C	-20...60 °C	-20...60 °C	-20...60 °C	-20...60 °C
Weight [kg]	0.32	0.32	0.32	0.32	0.32
Article no.	252 113	255 018	257 126	257 127	252 114

Electrical connection

Connection to the mains is made through pre-fabricated connection lines DEZ 1xx/2xx, which are available in different lengths.

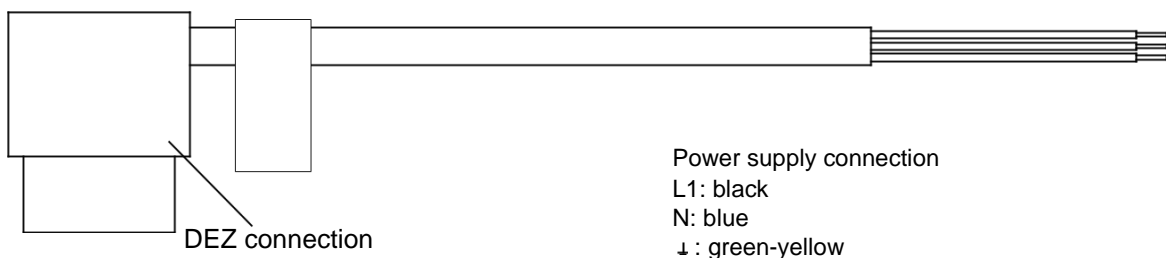

The ignition electrodes are connected via pre-fabricated carbon fibre ignition lines. The high line resistance of 10 kOhm/m effectively suppresses EMC faults.

The ignition lines are fitted with an insulated 6.5 mm angle plug on the electrode side.



Dimensions

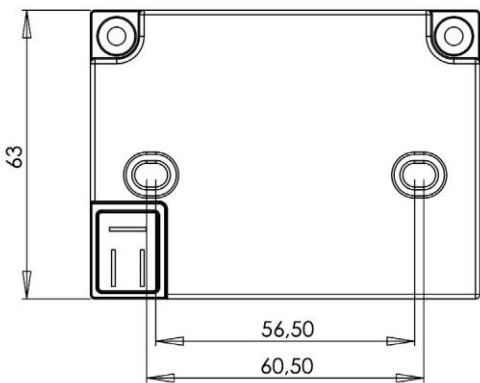
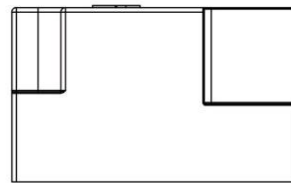
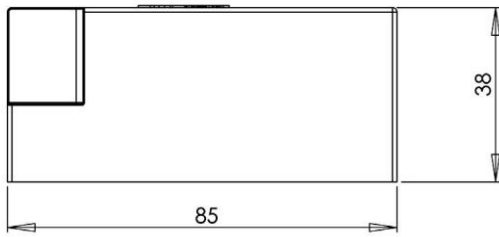

Attention

The operation of the DEZ ignition transformers produces very high voltages. The ignition transformers may only be put into operation if the ignition electrodes were built into the burner / burner chamber touch-proof and all live connections by means of the lines provided for this purpose were made touch-proof.

The length of the ignition line(s) must not exceed 1 m.

Connecting the protective earth is mandatory.

In the "SEO" version for single-electrode operation, the protective earth is connected to terminal 5 of the MPA 41xx.



บริษัท เอดีดี เฟอร์เนส จำกัด

ADD FURNACE CO.,LTD.

44 ซอยบรมราชชนนี 70 ถนนบรมราชชนนี แขวงศาลาธรรมสพน์ เขตทวีวัฒนา กรุงเทพฯ 10170

โทร: 02-888-3472 โทร: ออกแบบ:08-08-170-170 แฟกซ์: 02-888-3258

<https://www.add-furnace.com> E-mail: sales@add-furnace.com

VisionBox

The VisionBox is used for access to the
MPA via a PC.

www.dungs.com/softwaretools



บริษัท เอดีดี เฟอร์เนส จำกัด

ADD FURNACE CO.,LTD.

44 ซอยบรมราชชนนี 70 ถนนบรมราชชนนี แขวงศาลาธรรมสพน์ เขตทวีวัฒนา กรุงเทพฯ 10170

โทร: 02-888-3472 โทร: ออกแบบ:08-08-170-170 แฟกซ์: 02-888-3258

<https://www.add-furnace.com> E-mail: sales@add-furnace.com

DUNGS[®]
Combustion Controls

www.dungs.com