



Gas Appliance Pressure Regulators

FRS 7../6 Series FRS 5... Series



CSA Certified

- ANSI Z21.18 / CSA 6.3 as a Gas Appliance Pressure Regulator
- File # 1205910

NPT Threaded Versions

- FRS 705/6 (1/2" NPT)
- FRS 707/6 (3/4" NPT)
- FRS 710/6 (1" NPT)
- FRS 712/6 (1 1/4" NPT)
- FRS 715/6 (1 1/2" NPT)
- FRS 720/6 (2" NPT)
- FRS 725/6 (2 1/2" NPT)
- FRS 730/6 (3" NPT)

ISO Flanged Versions

- FRS 5040 (1 1/2")
- FRS 5050 (2")
- FRS 5065 (2 1/2")
- FRS 5080 (3")
- FRS 5100 (4")
- FRS 5125 (5")
- FRS 5150 (6")

Commonwealth of Massachusetts Approved Product

- Approval code G1-1107-35
- Gas pressure regulator

Codes and Standards

This product is intended for installations covered by but not limited to NFPA 37, NFPA 86, NFPA 54, CSD-1, UL 795, ANSI Z83.4, ANSI Z83.18, ANSI Z21.13, CSA B149.1, CSA B149.3 and CSA B149.6.

DUNGS is an ISO 9001 manufacturing facility.



Description

The FRS 7../6 Threaded & FRS 5... Flanged balancing type pressure regulators are spring-loaded pressure regulators with an adjustable setpoint. Both feature an internal sensor for regulating output pressure.

- Input pressures up to 10 PSI (See specifications for more details) and NPT 1/2" to NPT 3" thread connections (FRS 7../6)
- Input pressures up to 7 PSI and DN 40 to DN 150 flanged connections (FRS 5... Flanged)
- Heavy duty diaphragm construction for durability and strength.
- Steady, precise and instantaneous regulation of the outlet pressure.
- Lock-up type regulator (see page 2 and 3 for details).

- Factory installed vent limiter. Review applicable codes for vent line requirements.

Application

The FRS series gas pressure regulators are recommended for industrial and commercial applications, and they are designed for high efficiency appliances, high-turn down appliances, appliances using direct spark ignition or hot surface ignition, and other applications requiring a high performance regulator. The FRS is suitable for dry natural gas, propane, butane, air and inert gases.

The FRS does not contain any non-ferrous metals and is suitable for gases containing no more than 0.1 % by volume, dry H₂S. A "dry" gas has a dew point lower than +15 °F and its relative humidity is less than 60 %.



FRS Spring-loaded pressure regulator with adjustable setpoint spring. Internal sensor for regulating output pressure.

Specifications

Body size (FRS 7../6 threaded series) pipe size (Type NPT)	705/6 1/2"	707/6 3/4"	710/6 1"	712/6 1 1/4"	715/6 1 1/2"	720/6 2"	725/6 2 1/2"	730/6 3"
Body size (FRS 5...flanged series) pipe size (Type ISO welded flange)	5040 1-1/2"	5050 2"	5065 2-1/2"	5080 3"	5100 4"	5125 5"	5150 6"	
	Connection flange as per DIN 2501 Part 1: Fits preweld flanges as per DIN 2633 (PN 16) DN 40 to DN 150, per ISO 7085 - 1 (PN 16), or per ISO 7005 - 2 (PN 16)							
Max. inlet operating pressure FRS 7../6	7 PSI (500 mbar) at ambient +5 to +160 °F and outlet 4 - 80"W.C. 5 PSI (350mbar) applies to CSA Certification. 10PSI(690mbar) versions available at ambient +5 to +160 °F and outlet 4 - 80"W.C.							
Max. inlet operating pressure FRS 5... Flanged	7 PSI (500 mbar) +5 °F to +150 °F (-15 °C to +70 °C) 5 PSI (350mbar) applies to CSA Certification							
Input pressure range for optimal control FRS 7../6	2 in. W.C. to 200 in. W.C. (5 mbar to 500 mbar)							
FRS 5... Flanged	2 in. W.C. to 200 in. W.C. (5 mbar to 500 mbar)							
Max. body pressure FRS 7../6	15 PSI (1000 mbar)							
FRS 5... Flanged	10 PSI (700 mbar)							
Output pressure range	1 in. W.C. to 80 in. W.C. (2.5 mbar to 200 mbar). See spring selection below.							
Materials in contact with gas	Housing:				Aluminum, steel (free of non-ferrous metals)			
	Seals and diaphragms:				NBR-based rubber			
Ambient temperature FRS 7../6	+5 °F to +160 °F for up to 10 PSI for regulating behavior (+/- 10% of setpoint). -40 °F to +160 °F for up to 5 PSI: Diaphragms are suitable for the low temperature, but there may be out of range regulating behavior. CSA Certified for -40 °F to +160 °F for up to 5 PSI.							
Ambient temperature FRS 5... Flanged	+5 °F to +150 °F for up to 7 PSI (-15 °C to +65 °C)							
Installation position	Regulator dome from vertically upright to lying horizontally							
Vent line connection / vent limiter	Vent line connection is G 1/4" for FRS's up to 1" NPT, and it is G 1/2" for FRS's 1 1/4 and larger. The FRS also has a factory installed vent limiter, which limits the escape of gas to less than 0.5 CFH @ 5 PSI in case atmospheric diaphragm ruptures. Venting required unless otherwise accepted by the authority having jurisdiction.							
Turndown	Rated for 20:1							
Hysteresis and Droop	Hysteresis/repeatability is less than 10% for up to 7 PSI inlet. Average droop at 20:1 turndown is 10% for up to 7 PSI.							
Lock-up Rating	<ul style="list-style-type: none"> • The FRS meets the ANSI Z.21.80/CSA 6.22 as Class I, which allows lockup rating not more than 150% or 5 in. W.C, whichever is greater. • The FRS meets EN 88-1 as SG30, which allows lock-up as high as +30% of the outlet pressure. • See Lock-up pressure parameters on page 3 for more details 							



Lock-up Rating Parameters

Per ANSI Z21.80, lock-up is defined as an outlet pressure not more than 150 % or 5 in. W.C, whichever is greater, above the setpoint after a downstream safety shutoff valve closes with 2 seconds, and the two following conditions exists:

- 1) outlet pressure is set to the highest set point of the spring, and
- 2) the regulator is set to maximum capacity or flow at which the regulator will control lockup pressure within the acceptable limits.

This means that in a given application, a lockup greater than 150 % or 5 in. W.C could occur, depending out the

inlet pressure, the outlet pressure of the regulator, the flow rate of the regulator, and the pipe volume downstream the regulator and upstream the safety shutoff valve.

Per EN 88-1, lock-up is +30 % of the outlet pressure setting after downstream shutoff valve slowly closes within 30 seconds. Therefore, in a given application, a lockup greater than +30 % or 5 in. W.C could occur, depending out the inlet pressure, the outlet pressure of the regulator, the flow rate of the regulator, and the pipe volume downstream the regulator and upstream the safety shutoff valve.

If in a given application the Lock-up pressure is too high, employing one or more of the following should reduce the lock-up pressure:

- 1) increase the size of the regulator.
- 2) increase the pipe volume downstream the regulator and upstream the safety shutoff valve.
- 3) decrease the inlet pressure.
- 4) decrease the outlet pressure.
- 5) reduce the flowrate.

Outlet Pressure Spring Selection (outlet pressure values are for horizontal pipe mounting)

The output pressure is controlled by the force of the adjustable spring. The pressure regulator is supplied with the blue spring No. 4. By exchanging springs, other output pressures can be attained. Subtract 1"W.C. when mounted vertically.

Spring Range (W.C.) Spring color	1 to 3.6 brown Not CSA	2 to 5 white	2.8 to 8 orange	4 to 12 blue Standard	10 to 22 red	12 to 28 yellow	24 to 40 black	40 to 60 pink	60 to 80 grey Not CSA
FRS 705/6	229817	229818	229820	229821	229822	229823	229824	229825	229826
FRS 707/6	229833	229834	229835	229836	229837	229838	229839	229840	229841
FRS 710/6	229842	229843	229844	229845	229846	229847	229848	229849	229850
FRS 712/6, 715/6, 5040	229851	229852	229853	229854	229869	229870	229871	229872	229873
FRS 720/6 & 5050	229874	229875	229876	229877	229878	229879	229880	229881	229882
FRS 725/6, 730/6, 5065, 5080	229883	229884	229885	229886	229887	229888	229889	229890	229891
FRS 5100	229892	229893	229894	229895	229896	229897	229898	229899	229900
FRS 5125	229901	229902	229903	229904	229905	229906	229907	229908	243416
FRS 5150	229909	229910	229911	229912	229-913	229914	229915	229916	243417



Pressure Taps - FRS 7../6 Threaded Version

- 1 Vent/breather connection
FRS 705/6 - FRS 710/6, G 1/4 in.
FRS 712/6 - FRS 730/6, G 1/2 in.
- 2 External feedback pressure connection
FRS 705/6 - FRS 710/6, G 1/4 in. - one side.
FRS 712/6 - FRS 730/6, G 1/4 in. - both sides.
- 3 Upstream pressure connection
FRS 705/6 - FRS 710/6, 1/4 in. NPT - one side.
FRS 705/6 - FRS 710/6, G 1/4 in. - one side.
FRS 712/6 - FRS 730/6, 1/4 in. NPT - both sides.
- 4 Downstream pressure connection
FRS 705/6 - FRS 710/6, 1/4 in. NPT - one side.
FRS 712/6 - FRS 730/6 1/4 in. NPT - both sides.

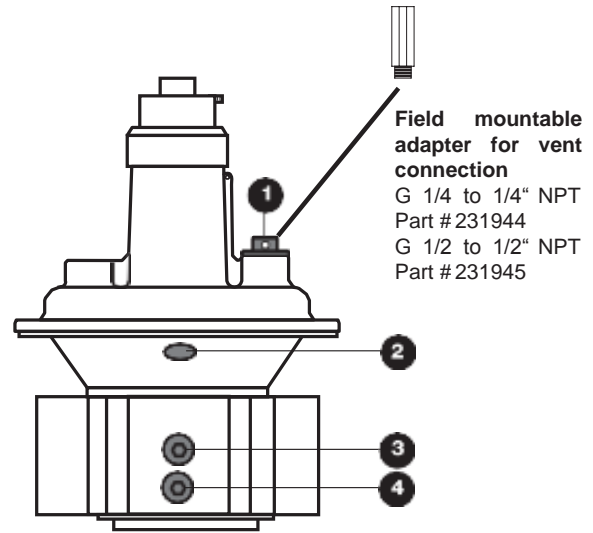

Test nipple G 1/8" Order No. 219-008
Test nipple G 1/4" Order No. 230-398A

Pressure Taps - FRS 5... Flanged Version FRS

- Flanged**
- 1 Vent/breather connection
FRS 5040 - FRS 5150, G 1/2 in.
- 2 External feedback pressure connection FRS
5040 - FRS 5150, both sides G 1/4 in. See
caution below.
- 3 Upstream pressure connection
FRS 5040 - FRS 5150, both sides G 1/4 in.
- 4 Downstream pressure connection FRS
5100 - 5125, both sides G 1/4 in.

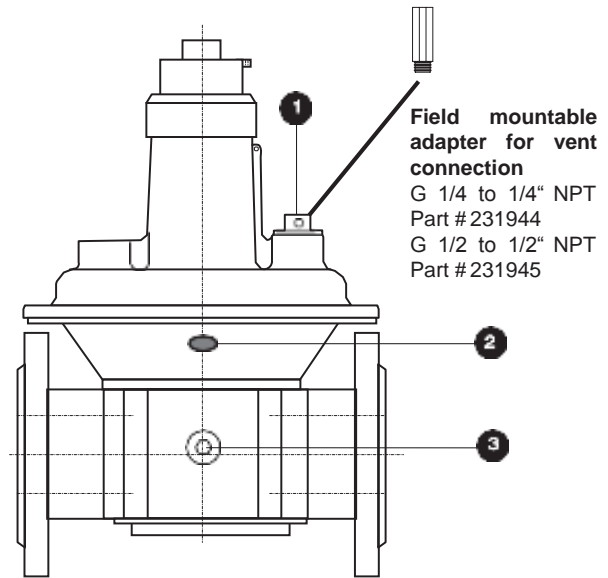

⚠ When using external feedback pressure connection, the internal feedback tube must be sealed with RTV.

FRS Flange Accessories

Body Size	Flange Description	# of Holes per Flange	Flange Order No.	Bolt size	**Bolt Order No.	***Gasket Order No.
FRS 5040	1 1/2" ISOFlanged	4	227137	M16x55	135930	267463
FRS 5050	2" ISOFlanged	4	227138	M16x65	135930	267464
FRS 5065	2 1/2" ISOFlanged	4	227139	M16x65	135930	267465
FRS 5065	2 1/2" ISO to NPT	4	243690	M16x65	135930	267465
FRS 5080	3" ISOFlanged	8	227140	M16x65	135930	267466
FRS 5080	3" ISO to NPT	8	243219	M16x65	135930	267466
FRS 5100	4" ISOFlanged	8	227141	M16x65	135930	267467
FRS 5125	5" ISOFlanged	8	227142	M16x75	148830	267468
FRS 5150	6" ISOFlanged	8	227143	M20x80	135950	030403

* When a control is used alone, one mating flange is needed for each end, for a total of two flanges. When one control is bolted to another, such as an FRS to a DMV dual modular safety valve, one mating flange is needed for each end, for a total of two flanges.

** Includes one bolt, one lock washer, and one nut.

*** One seal needed for each flange.



FRS 7../6 Dimensions inch

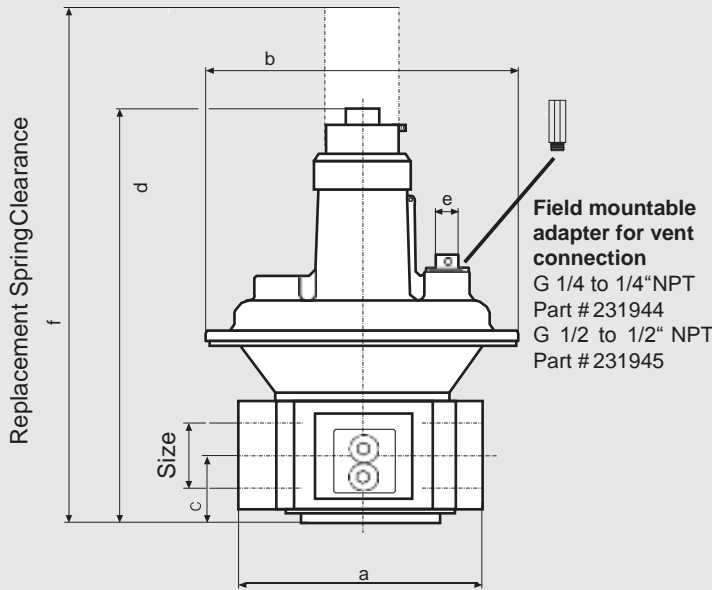

FRS 5... Flanged Dimensions inch

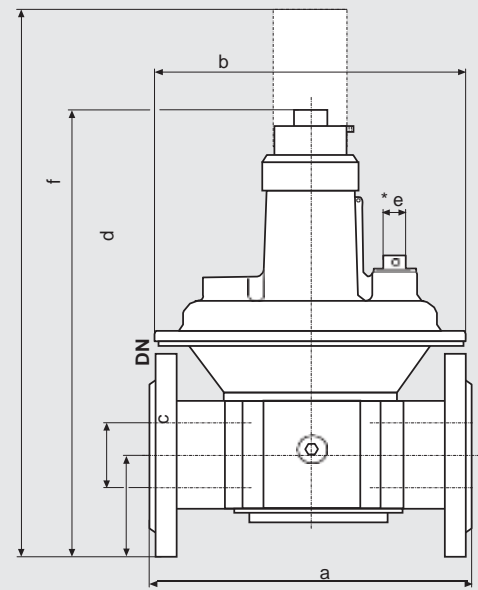

FRS 7../6 Threaded	Order No. 7 PSI max.	Order No. 10 PSI max.	Size	Dimensions [inch] Dimensions [mm]						Weight [lbs] [kg]
				a	b	c	d	e	f	
Type										
FRS 705/6	229595	269318	NPT 1/2	2.9 75	4.5 115	0.9 24	5.6 143	G 1/4	8.9 225	1.3 0.6
FRS 707/6	229608	267003	NPT 3/4	3.9 100	5.1 130	1.1 28	6.5 165	G 1/4	9.6 245	2.2 1.0
FRS 710/6	229609	267005	NPT 1	4.3 110	5.7 145	1.3 6	7.5 190	G 1/4	12.2 310	2.6 1.2
FRS 712/6	229610	267007	NPT 1 1/4	5.9 150	7.7 195	1.6 40	9.8 250	G 1/2	14.2 365	5.9 2.7
FRS 715/6	229611	267009	NPT 1 1/2	5.9 150	7.7 195	1.6 40	9.8 250	G 1/2	14.2 365	5.5 2.5
FRS 720/6	229612	267011	NPT 2	6.7 170	9.8 250	1.9 47	12.2 310	G 1/2	17.7 450	7.7 3.5
FRS 725/6	229613	269324	NPT 2 1/2	9.1 230	11.2 285	3.7 95	15.9 405	G 1/2	23.2 590	16.5 7.5
FRS 730/6	229614	269327	NPT 3	10.4 265	11.2 285	3.7 95	15.9 405	G 1/2	23.2 590	22.0 10.0

FRS 5... Flanged	Order No. internal pulse	Order No. external pulse	Pressure _{max} [PSI]	Size	Dimensions [inch] Dimensions [mm]						Weight [lbs] [kg]
					a	b	c	d	e	f	
Type											
FRS 5040	065144	214474	7	DN 40 (1 1/2")	7.9 200	7.7 195	2.6 65	11.0 280	G 1/2	15.6 395	7.7 3.5
FRS 5050	065151	183600	7	DN 50 (2")	9.1 230	9.9 250	3.0 75	13.4 340	G 1/2	18.9 480	11.0 5.0
FRS 5065	058792	183930	7	DN 65 (2 1/2")	11.4 290	11.2 285	3.7 95	16.0 405	G 1/2	23.2 590	16.5 7.5
FRS 5080	079681	not available	7	DN 80 (3")	12.2 310	11.2 285	3.7 95	16.0 405	G 1/2	23.2 590	22.1 10.0
FRS 5100	082552	211019	7	DN 100 (4")	13.8 350	13.8 350	4.1 105	19.5 495	G 1/2	29.9 760	35.3 16.0
FRS 5125	013250	208301	7	DN 125 (5")	15.8 400	15.8 400	5.3 135	25.0 635	G 1/2	39.4 1000	61.7 28.0
FRS 5150	013268	208302	7	DN 150 (6")	18.9 480	18.9 480	6.3 160	30.7 780	G 1/2	46.5 1180	83.8 38.0



FRS 7../6 sectional drawing

Pressure regulator in operating position

- 1 Housing
- 2 Regulating cup
- 3 Internal feedback tube
- 4 Balancing diaphragm
- 5 Diaphragm disk
- 6 Atmospheric diaphragm
- 7 Vent limiter
- 8 Vent line connection
- 9 Setpoint spring
- 10 Adjustment device

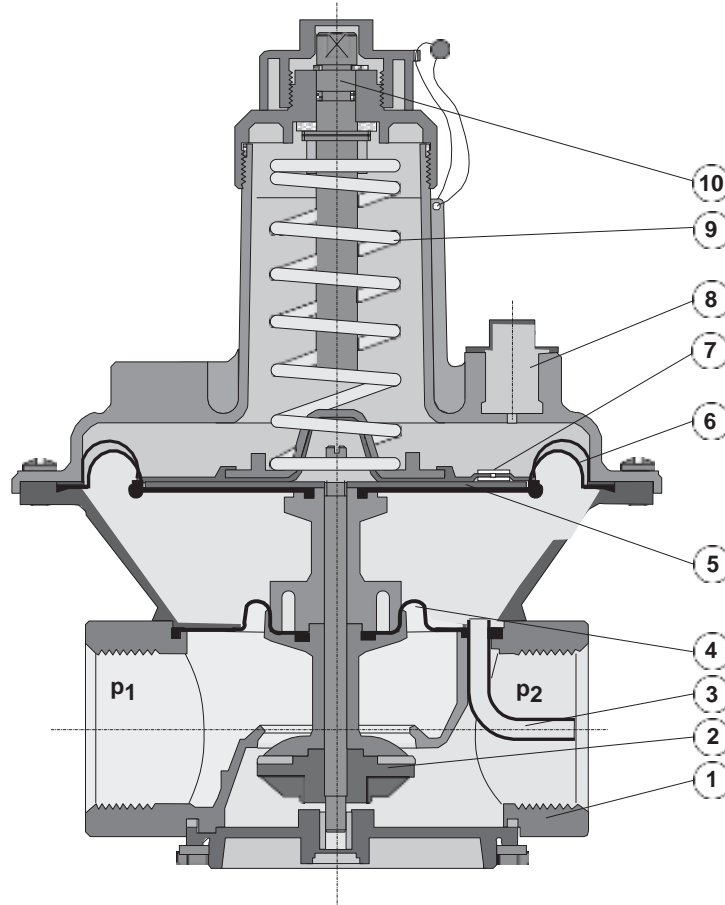

⚠ Protect the pressure regulator from debris by using a suitable filter.

Pressure drop for other gases

To determine the pressure drop when using a gas other than natural gas, use the flow formula below and f value located in the table below to determine

the “corrected” flow rate in CFH through the valve for the other gas used. For example, when using propane, divide the volume (CFH) of propane required for the application by the calculated value

f (f = 0.66 for propane). Use this “corrected” flow rate and the flow curve on the next page to determine pressure drop for propane.

Determining equivalent flow through valves using another gas

$$\dot{V}_{\text{gas used}} = \dot{V}_{\text{Natural gas}} \times f$$

$$f = \sqrt{\frac{\text{Density of Naturalgas}}{\text{Density of gas used}}}$$

Type of gas	Density [kg/m³]	s.g.	f
Natural gas	0.81	0.65	1.00
Butane	2.39	1.95	0.58
Propane	1.86	1.50	0.66
Air	1.24	1.00	0.80



บริษัท เอดีดี เฟอร์เนส จำกัด

ADD FURNACE CO.,LTD.

44 ซอยบรมราชชนนี 70 ถนนบรมราชชนนี แขวงศาลาธรรมสพน์ เขตทวีวัฒนา กรุงเทพฯ 10170

โทร: 02-888-3472 โทร: ออกแบบ:08-08-170-170 แฟกซ์: 02-888-3258

<https://www.add-furnace.com> E-mail: sales@add-furnace.com

Mechanically Opened Curve

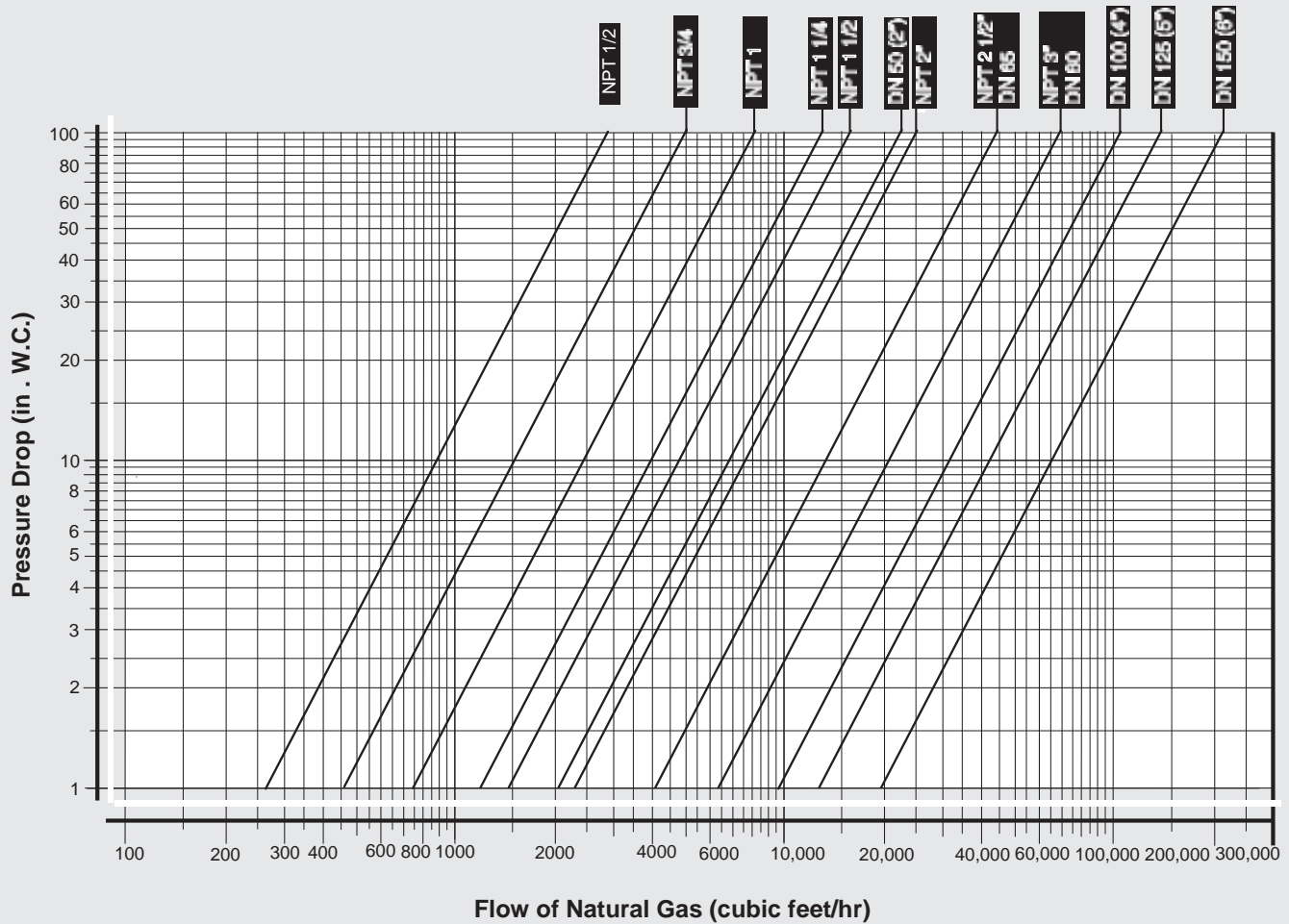



บริษัท เอดีดี เฟอร์เนส จำกัด

ADD FURNACE CO.,LTD.

44 ซอยบรมราชชนนี 70 ถนนบรมราชชนนี แขวงศาลาธรรมสพน์ เขตทวีวัฒนา กรุงเทพฯ 10170

โทร: 02-888-3472 โทร: ออกแบบ:08-08-170-170 แฟกซ์: 02-888-3258

https://www.add-furnace.com E-mail: sales@add-furnace.com

Gas Appliance Pressure Regulators

FRS 7../6 Series

FRS 5... Series



Flow Curve Using Natural Gas.

Use as a quick reference for sizing a regulator in the regulated state at:

Outlet pressure = 8 in. W.C.

Inlet pressure = 20 in. W.C.

Vmin = 0.05 x Vmax

Flow tables for other outlet pressures are available

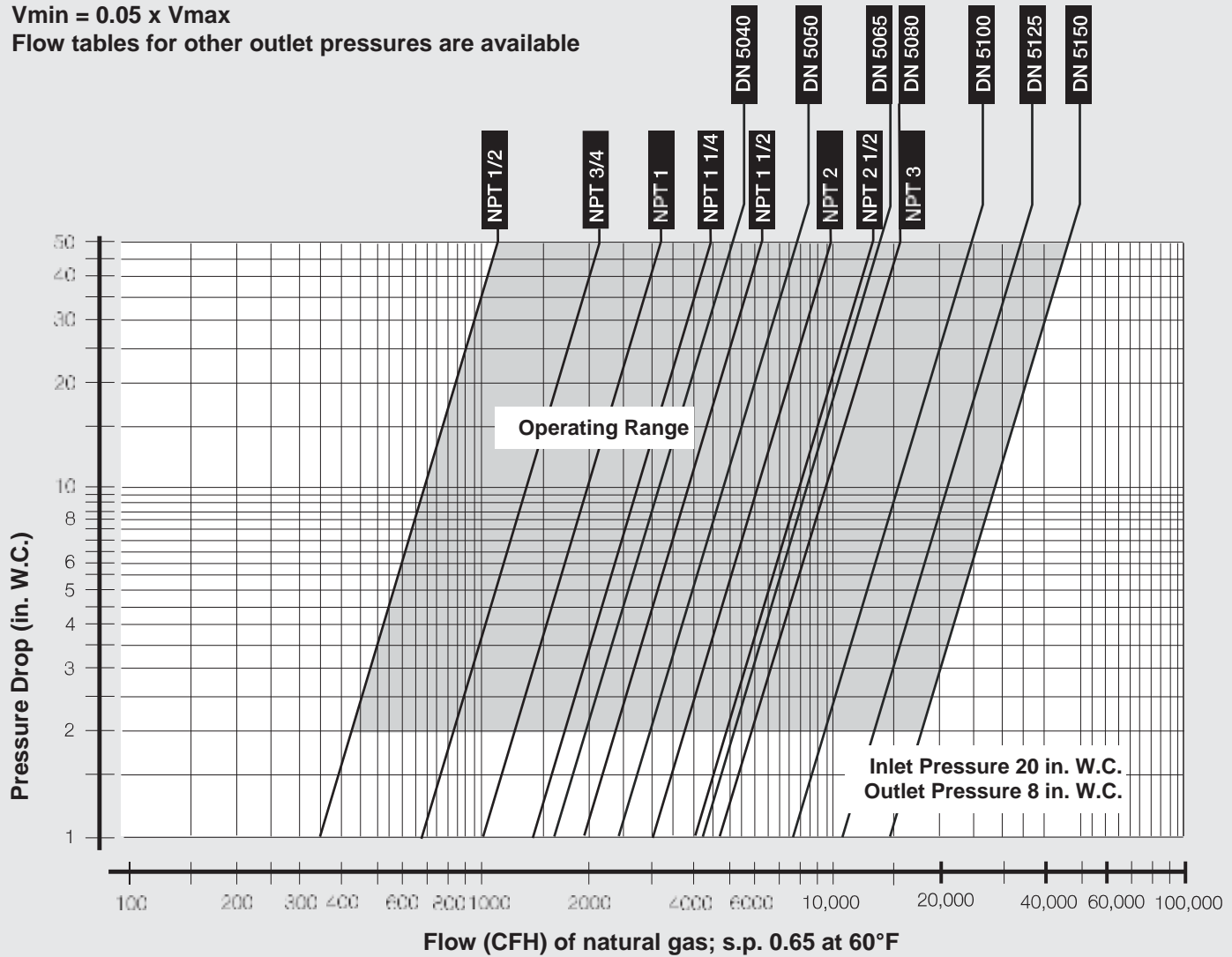

We reserve the right to make any changes in the interest of technical progress.