

January 2010

627 Series Pressure Reducing Regulators

WARNING

Failure to follow these instructions or to properly install and maintain this equipment could result in an explosion and/or fire causing property damage and personal injury or death.

Fisher® regulators must be installed, operated, and maintained in accordance with federal, state, and local codes, rules and regulations, and Emerson Process Management Regulator Technologies, Inc. instructions.

If the regulator vents gas or a leak develops in the system, service to the unit may be required. Failure to correct trouble could result in a hazardous condition.

Call a gas service person to service the unit. Only a qualified person must install or service the regulator.

Introduction

Scope of the Manual

This manual provides instructions for the installation, adjustment, maintenance, and parts ordering information for the 627 Series regulators. These regulators are usually shipped separate for line installation, although sometimes they are shipped installed on other equipment. Refer to the Instruction Manual of the other equipment for installation and operating instructions.

Description

The 627 Series direct-operated pressure reducing regulators (Figure 1) are for high and low pressure systems. These regulators can be used with natural gas, air, or a variety of other gases. Performance characteristics vary according to construction.



W4793

Figure 1. Typical 627 Series Direct-Operated Pressure Reducing Regulator

Specifications

The Specifications section gives some general specifications for the 627 Series regulators. The nameplates give detailed information for a particular regulator as it comes from the factory.

WARNING

Personal injury, property damage, equipment damage, or leakage due to escaping gas or bursting of pressure-containing parts may result if this regulator is overpressured or is installed where service conditions could exceed the limits given in Specifications section, Tables 1, 2, 3, and 4, or where conditions exceed any ratings of the adjacent piping or piping connections.



627 Series

Specifications

Available Constructions

Type 627: Direct-operated pressure reducing regulator equipped with a pitot tube for greater regulated capacities (Figure 7).

Type 627R: Type 627 with internal relief and with an open throat (Figure 8).

Type 627LR: Type 627R with light rate relief spring (Figure 9).

Type 627M: Type 627 with a stem seal between the body outlet pressure and diaphragm case. Pressure is measured under the diaphragm through the 1/4 NPT downstream control line connection (Figure 10).

Type 627MR: Type 627M with internal relief (Figure 11).

Type 627H: Type 627 with a diaphragm limiter to deliver a higher outlet pressure (Figure 12).

Type 627HM: Type 627H with a stem seal between the body outlet pressure and diaphragm case. Pressure is measured under the diaphragm through two 1/4 NPT downstream control line connections (Figure 13).

Body Sizes and End Connection Styles⁽¹⁾

BODY SIZES, NPS (DN)	END CONNECTION STYLES	CONSTRUCTION AVAILABLE
3/4	NPT	All
1 (DN 25)	NPT, CL150 RF, CL300 RF, CL600 RF, and Long Body	
2 (DN 50)	NPT, CL150 RF, CL300 RF, CL600 RF, and Long Body	

Maximum Inlet Pressure⁽¹⁾ (Body Rating)

NPT Steel: 2000 psig (138 bar)
Flanged Steel: 1500 psig (103 bar)
Ductile Iron: 1000 psig (69,0 bar)

Maximum Valve Disk Inlet Pressure Rating⁽¹⁾

Nylon (PA) Disk: 2000 psig (138 bar)
Nitrile (NBR) Disk: 1000 psig (69,0 bar)
Fluorocarbon (FKM) Disk: 300 psig (20,7 bar)

Maximum Operating Inlet Pressure, Pressure Differential, and Outlet Pressure Ranges⁽¹⁾

See Table 1 for pressures by orifice size and spring range

Maximum Spring and Diaphragm Casing Pressure⁽¹⁾

See Table 2

Maximum Body Outlet Pressure⁽¹⁾⁽³⁾ (Types 627M, 627MR, and 627HM Only)

NPT Steel: 2000 psig (138 bar)
Flanged Steel: 1500 psig (103 bar)
Ductile Iron: 1000 psig (69,0 bar)

Orifice Sizes

See Table 1

Internal Relief Performance

Type 627R: See Table 3
Type 627LR: See Table 4
Type 627MR: Limited by field-installed control line piping

Temperature Capabilities⁽¹⁾

-20° to 180°F (-29° to 82°C)

Flow Coefficients

See Table 5

IEC Sizing Coefficients

See Table 6

Pressure Registration

Type 627, 627H, 627R, or 627LR: Internal
Type 627M, 627HM, or 627MR: External through 1/4 NPT control line connection in the diaphragm casing

De-Icer System

See Figure 3 and Type 627M Regulator De-Icer System Application section

Relief Indicator

For Types 627R, 627LR, and 627MR (see Figures 8, 9, and 10)

Spring Case Vent Connection

3/4 NPT (internal) with removable screened vent assembly

Approximate Weights

Ductile Iron or Steel Casings: 10 pounds (4 kg)
Aluminum Casings: 6.3 pounds (3 kg)

1. The pressure/temperature limits in this Instruction Manual or any applicable standard limitation should not be exceeded.
 2. Types 627, 627H, 627R, and 627LR are limited by maximum diaphragm casing pressure.

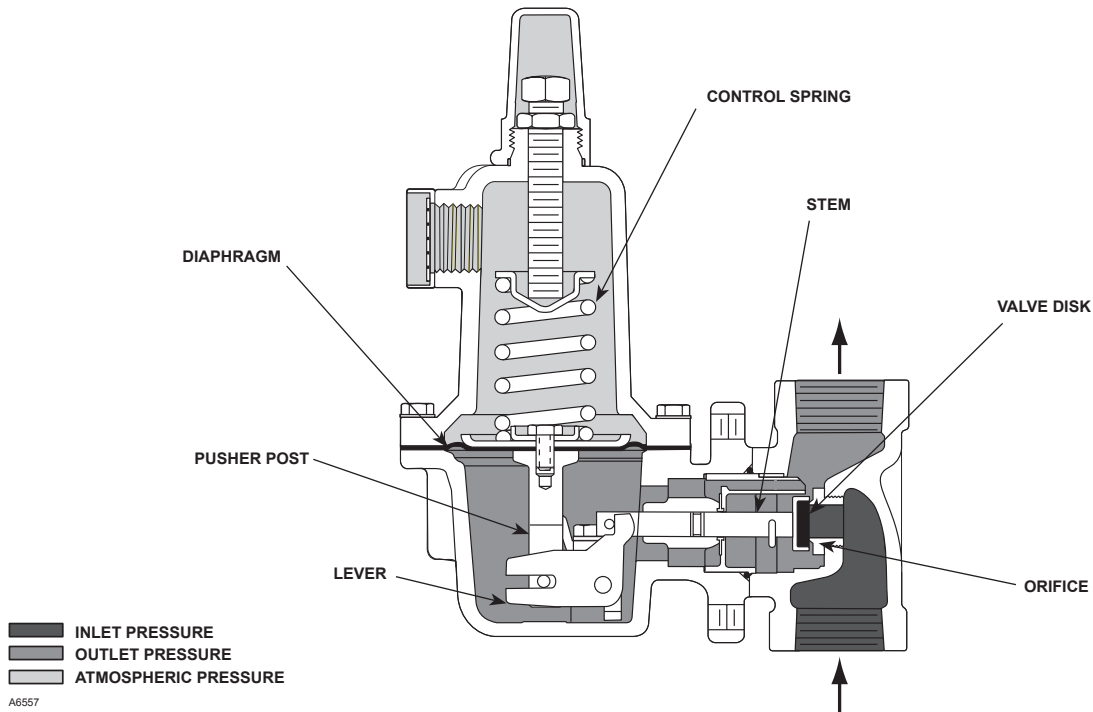

Figure 2. Type 627 Operational Schematic

To avoid such injury or damage, provide pressure-relieving or pressure-limiting devices (as required by the appropriate code, regulation, or standard) to prevent service conditions from exceeding those limits. The Type 627R, 627LR or 627MR regulator with internal relief will provide downstream overpressure protection within the limits given in Specifications section, Tables 1, 2, 3, and 4. If these limits are exceeded, additional downstream overpressure protection must be provided by the user.

Additionally, physical damage to the regulator could cause personal injury or property damage due to escaping gas. To avoid such injury or damage, install the regulator in a safe location.

Principle of Operation

Refer to Figure 2. When downstream demand decreases, the pressure under the diaphragm increases. This pressure overcomes the regulator setting (which is set by a spring). Through the action of the pusher post assembly, lever, and valve stem the valve disk moves closer to the orifice and reduces gas flow. If demand downstream increases, pressure

under the diaphragm decreases. Spring force pushes the pusher post assembly downward and the valve disk moves away from the orifice.

Construction Description

Types 627 and 627H Direct-Operated Pressure Reducing Regulators—The Types 627 and 627H regulators provide economical pressure reducing control for a variety of residential, commercial, and industrial applications. The regulator pitot tube located in a high velocity stream provides dynamic boost that compensates for outlet pressure drop.

Type 627 Long Body—The Type 627 Long Body regulator can be used as a drop-in replacement for existing Type 630 installations without the need to modify piping.

Internal Relief for Type 627R, 627LR, or 627MR Regulator—The Type 627R internal relief performance values were obtained by removing the disk assembly from the regulator. For the Type 627R, 627LR, or 627MR regulator, the internal relief across the diaphragm provides overpressure protection in many applications. As outlet pressures build-up above the start-to-discharge point, the diaphragm moves off the relief valve seat allowing the excess pressure to bleed out through the screened vent.

627 Series

Table 1. Maximum Inlet Pressures and Outlet Pressure Ranges

TYPES	OUTLET PRESSURE RANGE, SPRING PART NUMBER, AND COLOR	ORIFICE SIZE, INCHES (mm)	MAXIMUM INLET PRESSURE, PSIG (bar) ⁽¹⁾		
			Nylon (PA) Disk	Nitrile (NBR) Disk	Fluorocarbon (FKM) Disk
627 and 627M ⁽³⁾	5 ⁽²⁾ to 20 psig (0,34 to 1,4 bar) 10B3076X012 Yellow	3/32 (2,4)	2000 (138) ⁽¹⁾	1000 (69,0) ⁽¹⁾	300 (20,7)
		1/8 (3,2)	1000 (69,0) ⁽¹⁾	1000 (69,0) ⁽¹⁾	300 (20,7)
		3/16 (4,8)	750 (51,7)	750 (51,7)	300 (20,7)
		1/4 (6,4)	500 (34,5)	500 (34,5)	300 (20,7)
		3/8 (9,5)	300 (20,7)	300 (20,7)	300 (20,7)
		1/2 (13)	250 (17,2)	250 (17,2)	250 (17,2)
	15 to 40 psig (1,0 to 2,8 bar) 10B3077X012 Green	3/32 (2,4)	2000 (138) ⁽¹⁾	1000 (69,0) ⁽¹⁾	300 (20,7)
		1/8 (3,2)	1500 (103) ⁽¹⁾	1000 (69,0) ⁽¹⁾	300 (20,7)
		3/16 (4,8)	1000 (69,0) ⁽¹⁾	1000 (69,0) ⁽¹⁾	300 (20,7)
		1/4 (6,4)	750 (51,7)	750 (51,7)	300 (20,7)
		3/8 (9,5)	500 (34,5)	500 (34,5)	300 (20,7)
		1/2 (13)	300 (20,7)	300 (20,7)	300 (20,7)
35 to 80 psig (2,4 to 5,5 bar) 10B3078X012 Blue	3/32 (2,4)	2000 (138) ⁽¹⁾	1000 (69,0) ⁽¹⁾	300 (20,7)	
	1/8 (3,2)	2000 (138) ⁽¹⁾	1000 (69,0) ⁽¹⁾	300 (20,7)	
	3/16 (4,8)	1750 (121) ⁽¹⁾	1000 (69,0) ⁽¹⁾	300 (20,7)	
	1/4 (6,4)	1500 (103) ⁽¹⁾	1000 (69,0) ⁽¹⁾	300 (20,7)	
	3/8 (9,5)	1000 (69,0) ⁽¹⁾	1000 (69,0) ⁽¹⁾	300 (20,7)	
	1/2 (13)	750 (51,7)	750 (51,7)	300 (20,7)	
70 to 150 psig (4,8 to 10,3 bar) 10B3079X012 Red	3/32 (2,4)	2000 (138) ⁽¹⁾	1000 (69,0) ⁽¹⁾	300 (20,7)	
	1/8 (3,2)	2000 (138) ⁽¹⁾	1000 (69,0) ⁽¹⁾	300 (20,7)	
	3/16 (4,8)	2000 (138) ⁽¹⁾	1000 (69,0) ⁽¹⁾	300 (20,7)	
	1/4 (6,4)	1750 (121) ⁽¹⁾	1000 (69,0) ⁽¹⁾	300 (20,7)	
	3/8 (9,5)	1250 (86,2) ⁽¹⁾	1000 (69,0) ⁽¹⁾	300 (20,7)	
	1/2 (13)	750 (51,7)	750 (51,7)	300 (20,7)	
627R and 627MR	5 ⁽²⁾ to 20 psig (0,34 to 1,4 bar) 10B3076X012 Yellow	3/32 (2,4)	2000 (138) ⁽¹⁾	1000 (69,0) ⁽¹⁾	300 (20,7)
		1/8 (3,2)	1000 (69,0) ⁽¹⁾	1000 (69,0) ⁽¹⁾	300 (20,7)
		3/16 (4,8)	750 (51,7)	750 (51,7)	300 (20,7)
		1/4 (6,4)	500 (34,5)	500 (34,5)	300 (20,7)
		3/8 (9,5)	300 (20,7)	300 (20,7)	300 (20,7)
		1/2 (13)	200 (13,8)	200 (13,8)	200 (13,8)
	15 to 40 psig (1,0 to 2,8 bar) 10B3077X012 Green	3/32 (2,4)	2000 (138) ⁽¹⁾	1000 (69,0) ⁽¹⁾	300 (20,7)
		1/8 (3,2)	1500 (103) ⁽¹⁾	1000 (69,0) ⁽¹⁾	300 (20,7)
		3/16 (4,8)	1000 (69,0) ⁽¹⁾	1000 (69,0) ⁽¹⁾	300 (20,7)
		1/4 (6,4)	750 (51,7)	750 (51,7)	300 (20,7)
		3/8 (9,5)	300 (20,7)	300 (20,7)	300 (20,7)
		1/2 (13)	200 (13,8)	200 (13,8)	200 (13,8)
35 to 80 psig (2,4 to 5,5 bar) 10B3078X012 Blue	3/32 (2,4)	2000 (138) ⁽¹⁾	1000 (69,0) ⁽¹⁾	300 (20,7)	
	1/8 (3,2)	1750 (121) ⁽¹⁾	1000 (69,0) ⁽¹⁾	300 (20,7)	
	3/16 (4,8)	1000 (69,0) ⁽¹⁾	1000 (69,0) ⁽¹⁾	300 (20,7)	
	1/4 (6,4)	750 (51,7)	750 (51,7)	300 (20,7)	
	3/8 (9,5)	300 (20,7)	300 (20,7)	300 (20,7)	
	1/2 (13)	200 (13,8)	200 (13,8)	200 (13,8)	
70 to 150 psig (4,8 to 10,3 bar) 10B3079X012 Red	3/32 (2,4)	2000 (138) ⁽¹⁾	1000 (69,0) ⁽¹⁾	300 (20,7)	
	1/8 (3,2)	1000 (69,0) ⁽¹⁾	1000 (69,0) ⁽¹⁾	300 (20,7)	
	3/16 (4,8)	500 (34,5)	500 (34,5)	300 (20,7)	
	1/4 (6,4)	300 (20,7)	300 (20,7)	300 (20,7)	
	3/8 (9,5)	200 (13,8)	200 (13,8)	200 (13,8)	
	1/2 (13)	200 (13,8)	200 (13,8)	200 (13,8)	
627LR	15 to 40 psig (1,0 to 2,8 bar) 10B3077X012 Green	3/32 (2,4)		1000 (69,0) ⁽¹⁾	300 (20,7)
		1/8 (3,2)		1000 (69,0) ⁽¹⁾	300 (20,7)
627H and 627HM ⁽³⁾	140 to 250 psig (9,7 to 17,2 bar) 10B3078X012 Blue	3/16 (4,8)	1750 (121) ⁽¹⁾	1000 (69,0) ⁽¹⁾	
		1/4 (6,4)	1500 (103) ⁽¹⁾	1000 (69,0) ⁽¹⁾	
		3/8 (9,5)	1000 (69,0) ⁽¹⁾	300 (20,7)	
		1/2 (13)	750 (51,7)	200 (13,8)	
		3/32 (2,4)	2000 (138) ⁽¹⁾	1000 (69,0) ⁽¹⁾	
	240 to 500 psig (16,5 to 34,5 bar) 10B3079X012 Red	1/8 (3,2)	2000 (138) ⁽¹⁾	1000 (69,0) ⁽¹⁾	
		3/16 (4,8)	1750 (121) ⁽¹⁾	1000 (69,0) ⁽¹⁾	
		1/4 (6,4)	1500 (103) ⁽¹⁾	1000 (69,0) ⁽¹⁾	
		3/8 (9,5)	1000 (69,0) ⁽¹⁾	1000 (69,0) ⁽¹⁾	
		1/2 (13)	750 (51,7)	750 (51,7)	

1. For inlet pressure in excess of 1000 psig (69,0 bar), refer to the maximum body and disk pressure ratings in the Specifications section.
 2. For pressure settings under 10 psig (0,69 bar), inlet pressure should be limited to approximately 100 psig (6,9 bar) so the setpoint adjustment can be obtained.
 3. The unbalance forces change from the wide-open monitor mode to an active regulator mode such that the Type 627M or 627HM should have a 3/8-inch (9,5 mm) or larger orifice.
 ■ - Shaded areas indicate that Fluorocarbon (FKM) and Nylon (PA) disk material are not available.

Table 2. Maximum Spring and Diaphragm Casing Pressure⁽¹⁾

MAXIMUM PRESSURE DESCRIPTION	DIAPHRAGM CASING MATERIAL	TYPE 627, PSIG (bar)	TYPE 627R AND 627LR, PSIG (bar)	TYPE 627M, PSIG (bar)	TYPE 627MR, PSIG (bar)	TYPES 627H AND 627HM, PSIG (bar)
Maximum pressure to spring and diaphragm casings to prevent leak to atmosphere other than relief action (internal parts damage may occur)	Die cast aluminum	250 (17,2)	250 (17,2)	Not Available	Not Available	Not Available
	Ductile iron			250 (17,2)		
	Steel			250 (17,2)		
Maximum pressure to spring and diaphragm casings to prevent burst of casings during abnormal operation (leak to atmosphere and internal parts damage may occur)	Die cast aluminum	375 (25,9)	375 (25,9)	Not Available	Not Available	Not Available
	Ductile iron	465 (32,1)	465 (32,1)	465 (32,1)	465 (32,1)	
	Steel	1500 (103)	1500 (103)	1500 (103)	1500 (103)	
Maximum diaphragm casing overpressure (above setpoint) to prevent damage to internal parts	All materials	60 (4,1)	120 (8,3)	60 (4,1)	120 (8,27)	120 (8,27)

1. If the spring case is pressurized, a metal adjusting screw cap is required. Contact your local Sales Office for details.

For extra protection, should failure conditions exist which would prevent normal operation of the regulator (for example, disk broken off or disk erosion), the pusher post contacts the lever retainer causing the relief valve assembly to open. Since the diaphragm continues to rise as downstream pressure builds, it opens the relief valve; thereby, opening the valve. This internal relief may be adequate for the application.

Downstream Control Line for Type 627M, 627HM, or 627MR Regulator—A Type 627M, 627HM, or 627MR regulator has a blocking throat stem seal with O-rings and a 1/4 NPT control line connection in the diaphragm case. A regulator with a downstream control line is used for monitoring applications or other applications where other equipment is installed between the regulator and the pressure control point. The stem seal separates the body outlet pressure from the diaphragm case.

Installation

Regulator operation within ratings does not preclude the possibility of damage from debris in the lines or from external sources. A regulator should be inspected for damage periodically and after any overpressure condition. Key numbers referenced in this section are shown in Figures 7 through 13. Ensure that the operating temperature capabilities listed in Specifications section are not exceeded.

627 Series regulators have outlet pressure ratings that are lower than their inlet pressure ratings. A pressure-relieving or pressure-limiting device must be provided by the user for the Types 627, 627H, 627M, and 627HM regulators if the inlet pressure can exceed the outlet pressure rating, since these regulators do not have internal relief.

Types 627R and 627LR regulators provide internal relief which limits the total outlet pressure build-up over setpoint. Use Tables 3 and 4 to determine the total

outlet pressure. This internal relief may be adequate for the application, if not, provide additional pressure relief or a pressure-limiting device downstream.

Note

If the regulator is shipped mounted on another unit, install that unit according to the appropriate instruction manual.

Perform steps 1 through 6 for all types of regulators:

1. Only personnel qualified through training and experience should install, operate, or maintain this regulator.
2. For a regulator that is shipped separately, make sure that there is no damage to or foreign material in the regulator.
3. Ensure that all tubing and piping have been blown free of foreign debris.
4. The regulator may be installed in any position as long as the flow through the body is in the direction indicated by the arrow cast on the body.
5. If continuous operation is required during inspection or maintenance, install a three-valve bypass around the regulator.



WARNING

A regulator may vent some gas to the atmosphere. In hazardous or flammable gas service, vented gas may accumulate and cause personal injury, death, or property damage due to fire or explosion. Vent a regulator in hazardous gas service to a remote, safe location away from air intakes or any hazardous area. The vent line or stack opening must be protected against condensation or clogging.

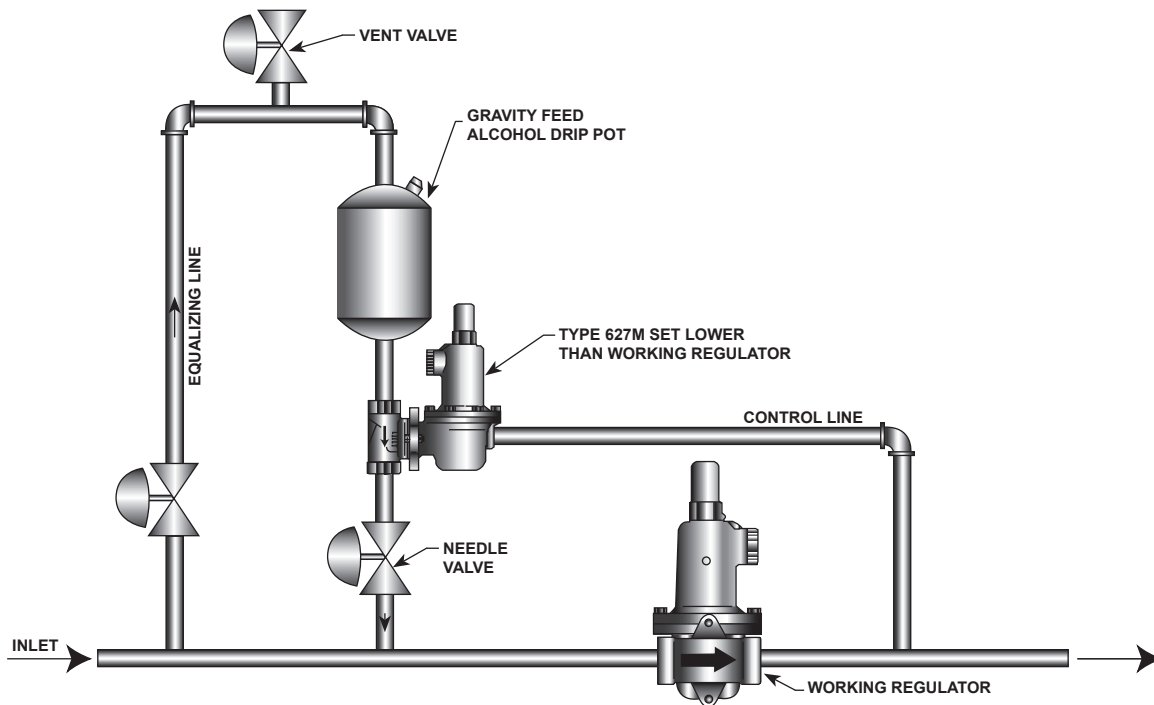

A3725

Figure 3. De-Icer System Operational Schematic

- Position the body (key 1) and/or diaphragm spring case (key 29) so it will not collect moisture or debris into the screened vent. If the regulator requires repositioning, refer to the Body Area Maintenance Procedures and/or the Diaphragm and Spring Case Area Maintenance Procedures in the Maintenance section to reposition the screened vent for the application.

Perform steps 7 through 9 for Types 627M, 627HM, and 627MR regulators only:

- A Type 627M, 627HM, or 627MR regulator requires a downstream control line. Install the control line before putting the regulator into operation.
- Ensure that the downstream control line piping is at least 3/8-inch (9,5 mm) or larger outside diameter tubing and connected to a straight section of outlet piping 10 diameters downstream of the regulator.
- A hand valve should be installed in the control line. This hand valve can be used to throttle down and dampen outlet pulsations in control pressure which may cause instability or cycling of the regulator.

Remote Vent Line Installation

All 627 Series regulators have a vent assembly installed in the 3/4 NPT spring case vent opening. The vent assembly can be removed to install a remote

vent line if necessary. Remote vent lines must have the largest practical diameter. It should be as short as possible with minimum number of bends or elbows.

Protect the remote vent opening against entrance of rain, snow, or any other foreign material that may plug the vent or vent line and prevent proper operation of the regulator. Periodically check the vent opening to be sure it is not plugged with foreign debris.

Type 627M or 627HM Regulator De-Icer System Application

For the Type 627M or 627HM regulator de-icer system, refer to the application shown in Figure 3. With a large pressure drop across the working regulator, ice can form within this regulator. The formation of ice decreases the size of the orifice, so the regulator is unable to supply enough flow to satisfy the downstream demand. When the downstream pressure falls below the outlet pressure setting of the Type 627M or 627HM regulator, the disk assembly of the Type 627M or 627HM regulator moves off its orifice, permitting alcohol to flow into the main gas line. The alcohol carried to the main regulator by the flowstream prevents additional ice from forming on the orifice. When normal flow resumes, and as pressure in the downstream system is restored, the Type 627M or 627HM regulator shuts off.

Table 3. Type 627R Internal Relief Performance⁽¹⁾

OUTLET PRESSURE RANGE, SPRING PART NUMBER, AND COLOR	OUTLET PRESSURE SETTING, PSIG (bar)	MAXIMUM ALLOWABLE DOWNSTREAM SYSTEM PRESSURE, PSIG (bar)	MAXIMUM INLET PRESSURE TO KEEP MAXIMUM ALLOWABLE DOWNSTREAM SYSTEM PRESSURE FROM BEING EXCEEDED, PSIG (bar) ⁽²⁾					
			Orifice Size, Inches (mm)					
			3/32 (2,4)	1/8 (3,2)	3/16 (4,8)	1/4 (6,4)	3/8 (9,5)	1/2 (13)
5 ⁽³⁾ to 20 psig (0,34 to 1,4 bar) 10B3076X012 Yellow	10 (0,69)	60 (4,1)	1250 (86,2)	740 (51,0)	320 (22,1)	190 (13,1)	95 (6,6)	75 (5,2)
		100 (6,9)	2000 (138)	1500 (103)	620 (42,7)	390 (26,9)	180 (12,4)	130 (9,0)
		125 (8,6)	2000 (138)	1900 (131)	830 (57,2)	480 (33,1)	220 (15,2)	160 (11,0)
		175 (12,1)	2000 (138)	2000 (138)	1100 (75,8)	670 (46,2)	320 (22,1)	220 (15,2)
		200 (13,8)	2000 (138)	2000 (138)	1300 (89,6)	770 (53,1)	360 (24,8)	260 (17,9)
		250 (17,2)	2000 (138)	2000 (138)	1600 (110)	960 (66,2)	450 (31,0)	320 (22,1)
	15 (1,0)	60 (4,1)	1000 (69,0)	620 (42,7)	260 (17,9)	170 (11,7)	90 (6,2)	70 (4,8)
		100 (6,9)	2000 (138)	1400 (96,5)	610 (42,1)	370 (25,5)	170 (11,7)	130 (9,0)
		125 (8,6)	2000 (138)	1900 (131)	810 (55,8)	480 (33,1)	220 (15,2)	160 (11,0)
		175 (12,1)	2000 (138)	2000 (138)	1100 (75,8)	670 (46,2)	320 (22,1)	220 (15,2)
		200 (13,8)	2000 (138)	2000 (138)	1300 (89,6)	770 (53,1)	360 (24,8)	260 (17,9)
		250 (17,2)	2000 (138)	2000 (138)	1600 (110)	960 (66,2)	450 (31,0)	320 (22,1)
20 (1,4)	60 (4,1)	850 (58,6)	490 (33,8)	210 (14,5)	130 (9,0)	80 (5,5)	65 (4,5)	
	100 (6,9)	2000 (138)	1300 (89,6)	600 (41,4)	360 (24,8)	170 (11,7)	120 (8,3)	
	125 (8,6)	2000 (138)	1800 (124)	800 (55,2)	480 (33,1)	220 (15,2)	160 (11,0)	
	175 (12,1)	2000 (138)	2000 (138)	1100 (75,8)	670 (46,2)	320 (22,1)	220 (15,2)	
	200 (13,8)	2000 (138)	2000 (138)	1300 (89,6)	770 (53,1)	360 (24,8)	260 (17,9)	
	250 (17,2)	2000 (138)	2000 (138)	1600 (110)	960 (66,2)	450 (31,0)	320 (22,1)	
15 to 40 psig (1,0 to 2,8 bar) 10B3077X012 Green	15 (1,0)	60 (4,1)	1000 (69,0)	380 (26,2)	210 (14,5)	130 (9,0)	80 (5,5)	65 (4,5)
		100 (6,9)	2000 (138)	1300 (89,6)	590 (40,7)	350 (24,1)	170 (11,7)	120 (8,3)
		125 (8,6)	2000 (138)	1800 (124)	800 (55,2)	470 (32,4)	220 (15,2)	160 (11,0)
		175 (12,1)	2000 (138)	2000 (138)	1100 (75,8)	640 (44,1)	320 (22,1)	220 (15,2)
		200 (13,8)	2000 (138)	2000 (138)	1300 (89,6)	780 (53,8)	370 (25,5)	260 (17,9)
		250 (17,2)	2000 (138)	2000 (138)	1600 (66,2)	960 (66,2)	450 (31,0)	320 (22,1)
	20 (1,4)	60 (4,1)	630 (43,4)	200 (13,8)	150 (10,3)	100 (6,9)	70 (4,8)	65 (4,5)
		100 (6,9)	2000 (138)	1200 (82,7)	550 (37,9)	330 (22,8)	160 (11,0)	120 (8,3)
		125 (8,6)	2000 (138)	1700 (117)	760 (52,4)	450 (31,1)	210 (14,5)	160 (11,0)
		175 (12,1)	2000 (138)	2000 (138)	1100 (75,8)	630 (43,4)	320 (22,1)	220 (15,2)
		200 (13,8)	2000 (138)	2000 (138)	1300 (89,6)	770 (53,1)	360 (24,8)	260 (17,9)
		250 (17,2)	2000 (138)	2000 (138)	1600 (66,2)	960 (66,2)	460 (31,7)	320 (22,1)
30 (2,1)	100 (6,9)	2000 (138)	950 (65,5)	450 (31,1)	260 (17,9)	140 (9,7)	110 (7,6)	
	125 (8,6)	2000 (138)	1500 (103)	670 (46,2)	400 (27,6)	190 (13,1)	150 (10,3)	
	175 (12,1)	2000 (138)	2000 (138)	1000 (69,0)	610 (42,1)	300 (20,7)	220 (15,2)	
	200 (13,8)	2000 (138)	2000 (138)	1200 (82,7)	760 (52,4)	360 (24,8)	260 (17,9)	
	250 (17,2)	2000 (138)	2000 (138)	1600 (110)	970 (66,9)	460 (31,7)	320 (22,1)	
	40 (2,8)	100 (6,9)	1500 (103)	700 (48,3)	330 (22,8)	200 (13,8)	120 (8,3)	108 (7,4)
125 (8,6)		2000 (138)	1300 (89,6)	560 (38,6)	340 (23,4)	180 (12,4)	140 (9,7)	
175 (12,1)		2000 (138)	1800 (124)	1000 (69,0)	550 (37,9)	290 (20,0)	220 (15,2)	
200 (13,8)		2000 (138)	2000 (138)	1200 (82,7)	730 (50,3)	350 (24,1)	250 (17,2)	
250 (17,2)		2000 (138)	2000 (138)	1600 (110)	970 (66,9)	460 (31,7)	320 (22,1)	

1. The internal relief performance values are obtained by removing the disk assembly.
2. For inlet pressures in excess of 1000 psig (69,0 bar), refer to the maximum body and disk pressure ratings in the Specifications section.
3. For pressure settings under 10 psig (0,69 bar), inlet pressure should be limited to approximately 100 psig (6,9 bar) so the setpoint adjustment can be obtained.
 - Shaded areas indicate maximum inlet pressures allowed during system malfunction only. Table 1 gives the maximum inlet pressure for normal regulator operation.

- continued -

Startup and Adjustment

Startup



WARNING

To avoid personal injury or property damage due to explosion or damage to regulator or downstream components during startup, release downstream pressure to prevent an overpressure condition on the diaphragm of the regulator.

In order to avoid an overpressure condition and possible equipment damage, pressure gauges should always be used to monitor pressures during startup.

1. Slowly open the upstream shutoff valve.
2. Slowly open the downstream shutoff valve.
3. Check all connections for leaks.
4. Make final control spring adjustments according to the adjustment procedures.

627 Series

Table 3. Type 627R Internal Relief Performance⁽¹⁾ (continued)

OUTLET PRESSURE RANGE, SPRING PART NUMBER, AND COLOR	OUTLET PRESSURE SETTING, PSIG (bar)	MAXIMUM ALLOWABLE DOWNSTREAM SYSTEM PRESSURE, PSIG (bar)	MAXIMUM INLET PRESSURE TO KEEP MAXIMUM ALLOWABLE DOWNSTREAM SYSTEM PRESSURE FROM BEING EXCEEDED, PSIG (bar) ⁽²⁾					
			Orifice Size, Inches (mm)					
			3/32 (2,4)	1/8 (3,2)	3/16 (4,8)	1/4 (6,4)	3/8 (9,5)	1/2 (13)
35 to 80 psig (2,4 to 5,5 bar) 10B3078X012 Blue	40 (2,8)	125 (8,6)	2000 (138)	1100 (75,8)	500 (34,5)	300 (20,7)	170 (11,7)	140 (9,7)
		150 (10,3)	2000 (138)	1600 (110)	750 (51,7)	440 (30,3)	230 (15,9)	180 (12,4)
		175 (12,1)	2000 (138)	2000 (138)	980 (67,6)	580 (40,0)	290 (20,0)	220 (15,2)
		200 (13,8)	2000 (138)	2000 (138)	1200 (82,7)	720 (49,6)	340 (23,4)	250 (17,2)
		250 (17,2)	2000 (138)	2000 (138)	1600 (110)	940 (64,8)	450 (31,0)	320 (22,1)
	50 (3,4)	125 (8,6)	1400 (96,5)	820 (56,5)	400 (27,6)	230 (15,9)	150 (10,3)	140 (9,7)
		150 (10,3)	2000 (138)	1400 (96,5)	650 (44,8)	370 (25,5)	210 (14,5)	170 (11,7)
		175 (12,1)	2000 (138)	1900 (131)	700 (48,3)	530 (36,5)	270 (18,6)	210 (14,5)
		200 (13,8)	2000 (138)	2000 (138)	1100 (75,8)	670 (46,2)	330 (22,8)	240 (16,5)
		250 (17,2)	2000 (138)	2000 (138)	1500 (103)	920 (63,4)	430 (29,6)	320 (22,1)
	60 (4,1)	125 (8,6)	900 (62,1)	450 (31,0)	270 (18,6)	190 (13,1)	140 (9,7)	130 (9,0)
		150 (10,3)	1700 (117)	1100 (75,8)	540 (37,2)	300 (20,7)	190 (13,1)	160 (11,0)
		175 (12,1)	2000 (138)	1700 (117)	780 (53,8)	470 (32,4)	250 (17,2)	200 (13,8)
		200 (13,8)	2000 (138)	2000 (138)	1000 (69,0)	610 (42,1)	310 (21,4)	230 (15,9)
		250 (17,2)	2000 (138)	2000 (138)	1400 (96,5)	880 (60,7)	420 (29,0)	310 (21,4)
	70 (4,8)	150 (10,3)	1200 (82,7)	850 (58,6)	430 (29,6)	250 (17,2)	170 (11,7)	160 (11,0)
		175 (12,1)	2000 (138)	1400 (96,5)	670 (46,2)	400 (27,6)	230 (15,9)	190 (13,1)
		200 (13,8)	2000 (138)	2000 (138)	920 (63,4)	550 (37,9)	280 (19,3)	230 (15,9)
		250 (17,2)	2000 (138)	2000 (138)	1300 (89,6)	830 (57,2)	400 (27,6)	310 (21,4)
80 (5,5)	150 (10,3)	800 (55,2)	500 (34,5)	300 (20,7)	200 (13,8)	160 (11,0)	150 (10,3)	
	175 (12,1)	1500 (103)	1200 (82,7)	550 (37,9)	330 (22,8)	210 (14,5)	190 (13,1)	
	200 (13,8)	2000 (138)	1700 (117)	800 (55,2)	480 (33,1)	270 (18,6)	220 (15,2)	
	250 (17,2)	2000 (138)	2000 (138)	1200 (82,7)	770 (53,1)	390 (26,9)	300 (20,7)	
70 to 150 psig (4,8 to 10,3 bar) 10B3079X012 Red	70 (4,8)	175 (12,1)	1900 (131)	600 (41,4)	400 (27,6)	260 (17,9)	200 (13,8)	175 (12,1)
		200 (13,8)	2000 (138)	1200 (82,7)	630 (43,4)	380 (26,2)	250 (17,2)	210 (14,5)
		250 (17,2)	2000 (138)	2000 (138)	1100 (75,8)	680 (46,9)	360 (24,8)	290 (20,0)
	80 (5,5)	175 (12,1)	1400 (96,5)	250 (17,2)	240 (16,5)	200 (13,8)	190 (13,1)	175 (12,1)
		200 (13,8)	2000 (138)	960 (66,2)	520 (35,9)	330 (22,8)	240 (16,5)	210 (14,5)
100 (6,9)	200 (13,8)	2000 (138)	2000 (138)	1000 (69,0)	620 (42,7)	350 (24,1)	280 (19,3)	
	250 (17,2)	1500 (103)	250 (17,2)	240 (16,5)	230 (15,9)	210 (14,5)	210 (14,5)	
	250 (17,2)	2000 (138)	1600 (110)	770 (53,1)	520 (35,9)	320 (22,1)	270 (18,6)	
125 (8,6)	250 (17,2)	2000 (138)	1000 (69,0)	500 (34,5)	390 (26,9)	290 (20,0)	260 (17,9)	
150 (10,3)	250 (17,2)	1200 (82,7)	260 (17,9)	260 (17,9)	260 (17,9)	260 (17,9)	260 (17,9)	

1. The internal relief performance values are obtained by removing the disk assembly.
2. For inlet pressures in excess of 1000 psig (69,0 bar), refer to the maximum body and disk pressure ratings in the Specifications section.
3. For pressure settings under 10 psig (0,69 bar), inlet pressure should be limited to approximately 100 psig (6,9 bar) so the setpoint adjustment can be obtained.
■ - Shaded areas indicate maximum inlet pressures allowed during system malfunction only. Table 1 gives the maximum inlet pressure for normal regulator operation.

Table 4. Type 627LR Internal Relief Performance⁽¹⁾

OUTLET PRESSURE RANGE, SPRING PART NUMBER, AND COLOR	OUTLET PRESSURE SETTING, PSIG (bar)	MAXIMUM ALLOWABLE DOWNSTREAM SYSTEM PRESSURE, PSIG (bar)	MAXIMUM INLET PRESSURE TO KEEP MAXIMUM ALLOWABLE DOWNSTREAM SYSTEM PRESSURE FROM BEING EXCEEDED, PSIG (bar) ⁽²⁾			
			Orifice Size, Inches (mm)			
			3/32 (2,4)	1/8 (3,2)	3/16 (4,8)	1/4 (6,4)
15 to 40 Psig (1,03 to 2,8 bar) 10B3077X012 Green	30 (2,1)	55 (3,8)	500 (34,4)	270 (18,6)	110 (7,6)	80 (5,5)
		60 (4,1)	850 (58,6)	480 (33,0)	200 (13,8)	120 (8,3)
		66 (4,5)	1000 (69,0)	660 (45,5)	290 (20,0)	175 (12,0)
	40 (2,8)	66 (4,5)	380 (26,2)	190 (13,1)	85 (5,9)	80 (5,5)
		70 (4,8)	700 (48,2)	370 (25,5)	150 (10,3)	115 (7,9)
		75 (5,1)	1000 (69,0)	560 (38,6)	240 (16,4)	160 (11,0)

1. The internal relief performance values are obtained by removing the disk assembly.

Table 5. Flow Coefficients

ORIFICE, INCH (mm)	3/4 NPT			NPS 1 (DN 25) BODY			NPS 2 (DN 50) BODY		
	Wide-Open C _g for External Relief Sizing	Wide-Open C _g for External Relief Sizing	C ₁	Wide-Open C _g for External Relief Sizing	Wide-Open C _g for External Relief Sizing	C ₁	Wide-Open C _g for External Relief Sizing	Wide-Open C _g for External Relief Sizing	C ₁
3/32 (2,4)	6.9	0.24	29.2	6.9	0.24	28.5	6.9	0.23	29.7
1/8 (3,2)	12.5	0.43	29.1	12.5	0.43	29.4	12.5	0.42	29.5
3/16 (4,8)	29	1.01	28.6	29	0.93	31.2	29	1.02	28.5
1/4 (6,4)	50	1.63	30.6	50	1.71	29.3	52	1.66	31.3
3/8 (9,5)	108	2.99	36.1	108	3.42	31.6	115	3.39	33.9
1/2 (13)	190	4.87	39.0	190	5.29	35.9	200	5.01	39.9

Table 6. IEC Sizing Coefficients

ORIFICE SIZE, INCH (mm)	X_T			F_D	F_L
	3/4 NPT Body	NPS 1 (DN 25) Body	NPS 2 (DN 50) Body		
3/32 (2,4)	0.539	0.514	0.558	0.50	0.85
1/8 (3,2)	0.536	0.547	0.539		0.79
3/16 (4,8)	0.517	0.616	0.514		0.85
1/4 (6,4)	0.592	0.543	0.620		0.87
3/8 (9,5)	0.824	0.632	0.727		0.89
1/2 (13)	0.962	0.815	1.01		0.86

Table 7. Maximum Torque Values

KEY NUMBER ⁽¹⁾	DESCRIPTION	MAXIMUM TORQUE, FOOT-POUNDS (N•m)
2	Orifice	25 (34)
3	Cap screw (with aluminum diaphragm casing)	16 (22)
	Cap screw (with ductile iron or steel diaphragm casing)	25 (34)
18	Lever cap screw	7 (9,5)
22	Diaphragm connector nut	17 (23)
26	Guide retainer (for Types 627R, 627LR, and 627MR only)	3 (4,1)
37	Spring case cap screw (with aluminum or ductile iron diaphragm casing)	7 (9,5)
	Spring case cap screw (with steel diaphragm casing)	35 (47)
46	Diaphragm cap screw (with Type 627 or 627M)	7 (9,5)
	Diaphragm cap screw (with Type 627H or 627HM)	14 (19)

1. Refer to Figures 7 through 13 for key number locations.

Adjustment

The range of allowable pressure settings is marked on the nameplate. If a pressure setting beyond this range is necessary, substitute the appropriate regulator control spring. Change the nameplate to indicate the new pressure range.

Before increasing the setting, refer to Table 1, 2, 3, or 4. Review the pressure limits for the control spring range being used and be certain that the new pressure setting will not result in an overpressure condition.

Note

Always use a pressure gauge to monitor pressure when making adjustments.

Refer to Figures 7 through 13 for key number locations.

1. Remove the adjusting screw cap (key 36).
2. Loosen the locknut (key 34).
3. Increase the outlet pressure setting by turning the adjusting screw (key 35) clockwise. Decrease the outlet pressure setting by turning the adjusting screw counterclockwise.
4. When the desired pressure is obtained, hold the adjusting screw (key 35) in place and tighten the locknut (key 34).

Shutdown



WARNING

To avoid personal injury or property damage due to explosion or damage to regulator or downstream components during shutdown, release downstream pressure to prevent an overpressure condition on the diaphragm of the regulator.

1. Close the nearest upstream shutoff valve.
2. Close the nearest downstream shutoff valve.
3. Open the vent valve between the regulator and the downstream shutoff valve nearest to it.
4. For a Type 627, 627H, 627R, or 627LR regulator, the regulator will open to release pressure between the upstream shutoff valve and the regulator.
5. A Type 627M, 627HM, or 627MR regulator requires venting the control line and downstream pressure from the regulator before maintenance. The pressure between these shutoff valves is released through the open regulator because the disk assembly remains open in response to the decrease in control line pressure.

Maintenance

Unless otherwise specified, the following maintenance procedures apply to all types of regulators. For a summary of maximum torque values required for all types of regulators, refer to Table 7.

Due to normal wear, damage from external sources, or debris in the air or gas line, regulator parts such as the disk assembly, orifice, and diaphragm must be inspected periodically and replaced as necessary to ensure correct performance. The frequency of inspection and replacement depends upon the severity of conditions and the requirements of state and federal laws. Normal wear of the orifice and disk assembly is accelerated with high pressure drops and with large amounts of impurities in the flowstream. Instructions are given below for replacing the disk assembly, orifice, diaphragm, and O-rings. These procedures may also be used for disassembly required for inspection and replacement of other parts.

Problem Indication for Types 627R, 627LR, and 627MR Regulators

WARNING

Isolate the regulator from all pressure to avoid personal injury and equipment damage due to explosion or sudden release of process pressure. Cautiously release pressure from the regulator before attempting disassembly.

The vent assembly is equipped with a relief indicator (key 49, Figure 4). The cap for the relief indicator snaps over the vent assembly opening. If the relief valve opens wide, exhaust gas pops the cap off the screen vent assembly opening indicating a problem with the regulator. If the cap pops off, refer to the shutdown and to the Body Area Maintenance Procedures to inspect the disk assembly and orifice.

If the disk assembly and orifice are not damaged, refer to the Diaphragm and Spring Case Area Maintenance Procedures in this section.

The disk assembly and orifice can be inspected, removed, and replaced without removing the regulator body from the line connections. Refer to the Body Area Maintenance Procedures.

Body Area Maintenance Procedures

These procedures are for gaining access to the disk assembly, orifice, diaphragm casing O-ring, and stem

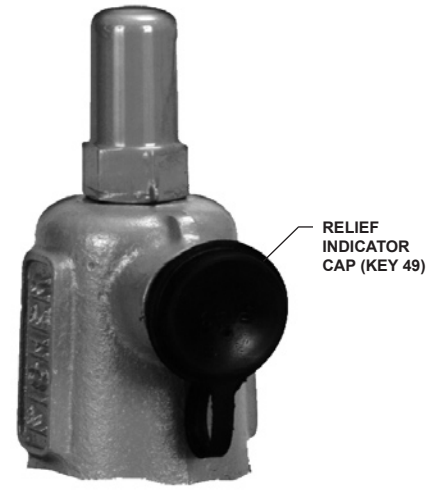

Figure 4. Relief Indicator

assembly. All pressure must be released from the diaphragm casing before performing these steps.

While using the following procedures, refer to Figures 7 through 13 for key number locations.

Replacing the Disk Assembly or Orifice

1. To inspect and replace the disk assembly (key 9) or orifice (key 2), remove the cap screws (key 3, Figure 5), and separate the diaphragm casing (key 5) from the body (key 1).
2. Inspect and, if necessary, remove the orifice (key 2). If removed, coat the threads of the replacement orifice with lubricant and torque to 25 foot-pounds (34 N•m).
3. Inspect the disk assembly and, if necessary, remove the hair pin clip (key 13) that holds the disk assembly (key 9) in place. If replacing the disk assembly is the only maintenance required, skip to step 16.

Replacing the Stem Assembly

If it is necessary to perform maintenance on the stem assembly, continue with steps 4 through 8 and 15 through 19 for Types 627, 627H, 627R, and 627LR regulators, or steps 9 through 19 for Types 627M, 627HM, and 627MR regulators.

Perform steps 4 through 8 for Types 627, 627H, 627R, and 627LR Regulators only:

4. Use steps 5 through 8 to remove and replace the stem assembly.
5. Remove the boost body (key 6), stabilizer (key 7), and stem guide (key 8) from the diaphragm casing (key 5). Unhook and remove the stem (key 10) from the diaphragm casing (key 5).

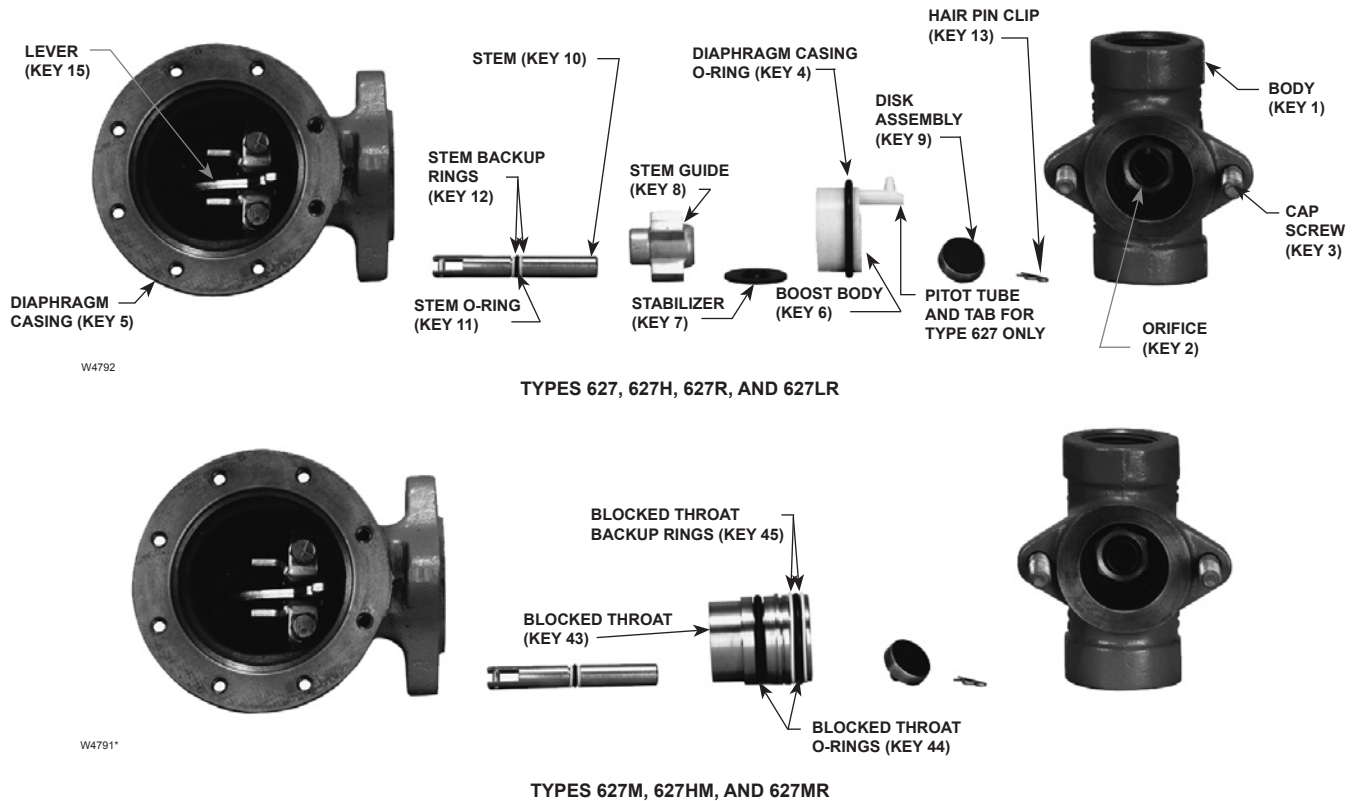

TYPES 627, 627H, 627R, AND 627LR

TYPES 627M, 627HM, AND 627MR

Figure 5. Stem Assemblies

6. Remove and inspect the diaphragm casing O-ring (key 4, Figure 7, 8, 9, or 12) and replace it if necessary.
7. Apply lubricant to a replacement diaphragm casing O-ring (key 4, Figure 7, 8, 9, or 12) and install it onto the boost body (key 6). Skip to step 14.
8. For the Type 627 or 627H regulators, be sure to insert the pitot tube (tab) into the outlet side of the body (see Figure 7 or 12). Skip to step 14.

Perform steps 9 through 19 for Types 627M, 627HM, and 627MR Regulators only:

9. Use steps 10 through 14 to remove and replace the stem assembly.
10. To remove the blocked throat (key 43), insert a screw driver blade into the groove provided in the throat and pry it out of the diaphragm casing (key 5). Inspect and replace parts as necessary.
11. Inspect and, if necessary, replace the blocked throat O-rings (key 44, Figure 5) and backup rings (key 45, Figure 5).
12. Apply lubricant to replacement blocked throat O-rings (key 44) and backup rings (key 45).
13. Apply lubricant to the replacement stem O-ring (key 11) and stem backup rings (key 12) and install them on the stem (key 10).
14. For assembly, lubricate the stem (key 10) and insert the diaphragm casing (key 5) and hook it on the lever (key 15).
15. Lubricate the contact points of the lever (key 15).
16. Insert parts into the diaphragm casing (key 5) that were removed in steps 5 and 6 or step 10 (see Figure 5).
17. Install the disk assembly (key 9), line up the hole in the disk assembly and stem (key 10) and insert the hair pin clip (key 13).
18. Position the diaphragm casing plus attached parts in relation to the body (key 1) so that they are correct for the application.
19. Secure the diaphragm casing to the body with the cap screws (key 3, Figure 5). For an aluminum diaphragm casing (key 5), torque the cap screws (key 3) to 16 foot-pounds (22 N•m). For ductile iron or steel diaphragm casings, torque the cap screws (key 3) to 25 foot-pounds (34 N•m).

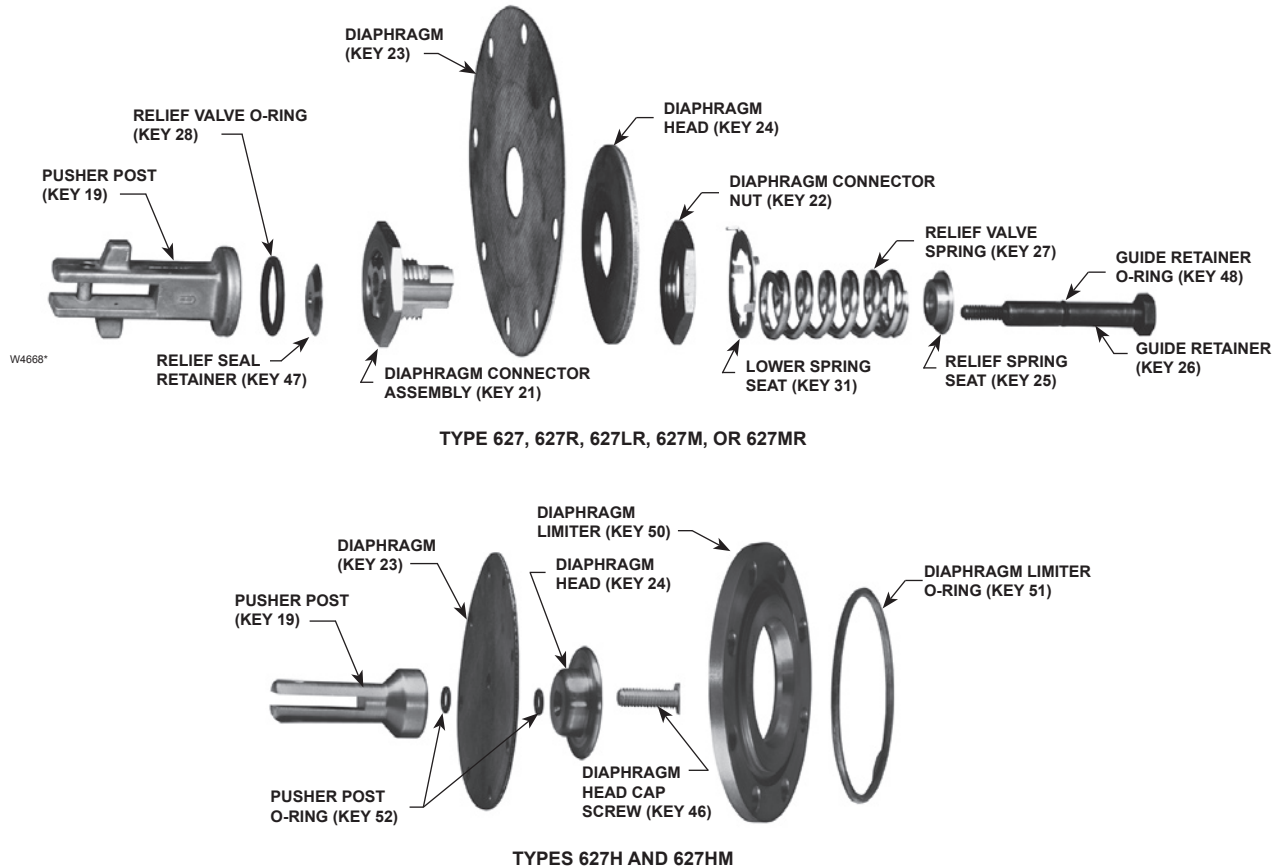

TYPE 627, 627R, 627LR, 627M, OR 627MR

TYPES 627H AND 627HM

Figure 6. Diaphragm Assemblies

20. It may be necessary to reposition the diaphragm spring case to prevent rain, ice, and foreign debris from entering the spring case. Refer to the Diaphragm and Spring Case Area Maintenance Procedures, steps 1, 2, and 21 through 25.

Diaphragm and Spring Case Area Maintenance Procedures

These procedures are for gaining access to the control spring, diaphragm assembly, and lever assembly. All spring pressure must be released from the diaphragm casing before these steps can be performed.

While using the following procedures, refer to Figures 7 through 13 for key number locations.

1. Remove the adjusting screw cap (key 36), loosen the lock nut, and turn the adjusting screw (key 35) counterclockwise until all compression is removed from the control spring (key 32).
2. Remove the spring case cap screws (key 37), the nameplates, and lift off the spring case (key 29). If changing the control spring (key 32)

or repositioning the spring case (key 29) is the only maintenance required, install the replacement control spring or rotate the spring case so it is correct for the application. Skip to step 21. For diaphragm area maintenance, continue with step 3.

3. Remove the diaphragm limiter O-ring and diaphragm limiter (keys 51 and 50, on the Type 627H or 627HM only). Remove the diaphragm assembly by tilting it so that the pusher post (key 19) slips off the lever (key 15).
4. If it is necessary to replace the lever assembly, remove the lever cap screws (key 18).
5. Install the replacement lever (key 15) into the lever retainer (key 16) by inserting the lever pin (key 17). Secure the lever assembly into the diaphragm casing with the cap screws (key 18) and torque the cap screws to 7 foot-pounds (9,5 N•m).

If it is necessary to perform maintenance on the diaphragm assembly, continue with steps 6 through 11 and step 20 for Types 627, 627H, 627M, and 627HM regulators, or steps 12 through 19 for Types 627R, 627LR, and 627MR regulators.

Perform steps 6 through 11 for Types 627, 627H, 627M, and 627HM Regulators only:

6. For Types 627, 627H, 627M, and 627HM regulators (Figures 5 and 6), use steps 7 through 11 to disassemble and reassemble the diaphragm assembly.
7. Remove the diaphragm head cap screw (key 46), lower spring seat (key 31, Type 627 or 627M only), and diaphragm head (key 24). On the Type 627H or 627HM, remove the pusher post O-rings (key 52). Separate the diaphragm (key 23) from the pusher post (key 19).
8. Install the diaphragm (key 23), in reverse order in step 7, on the pusher post (key 19), insert and finger tighten the diaphragm head cap screw (key 46).
9. Hook the pusher post on the lever (key 15), then turn the diaphragm (key 23) to match the holes in the diaphragm with the holes in the spring casing.
10. Unhook the pusher post from the lever and torque the diaphragm head cap screw (key 46) to 7 foot-pounds (9,5 N•m) for the Type 627 or 627M. On the Type 627H or 627HM, torque the diaphragm head cap screw to 14 foot-pounds (18 N•m).
11. Hook the pusher post on the lever (key 15) and check the hole alignment. If necessary, loosen the cap screw (key 46) and reposition the diaphragm (key 23) on the pusher post (key 19). Retorque the screw (see step 10). Skip to step 20.

Perform steps 12 through 19 for Types 627R, 627LR, and 627MR Regulators only:

12. For Types 627R, 627LR, and 627MR regulators (Figure 6), use steps 13 through 19 to disassemble and reassemble the diaphragm assembly.
13. Remove the guide retainer (key 26) and separate the diaphragm parts. Refer to Figure 6 for the sequence of parts.
14. To remove the diaphragm (key 23), remove the diaphragm connector nut (key 22) and lift off the diaphragm head (key 24) and diaphragm (key 23) from the connector assembly (key 21). Do not attempt to disassemble the connector assembly (key 21).
15. Position the replacement diaphragm (key 23) on the connector assembly (key 21), install the diaphragm head (key 24) and connector nut (key 22), then torque to 17 foot-pounds (32 N•m).

16. If necessary, replace the guide retainer O-ring (key 48) and, set the guide retainer (key 26) aside, ready for assembly.
17. On the pusher post (key 19) install the relief seal O-ring (key 28) and apply lubricant. Also, install the relief seal retainer (key 47), diaphragm connector assembly (key 21, with attached parts) relief spring (key 27), upper relief spring seat (key 33), and guide retainer (key 26). Torque the guide retainer (key 26) to 3 foot-pounds (4,1 N•m).
18. Hook the pusher post (with attached parts) on the lever (key 15) to check the alignment of the holes in the diaphragm with the holes in the spring casing. If the holes do not line up, unhook the pusher post from the lever, hold the pusher post, and rotate the diaphragm to the correct position.
19. Install the lower spring seat (key 31) over the relief spring so it rests flat on the connector nut (key 22).
20. Insert the diaphragm assembly into the diaphragm casing (key 5) and hook the pusher post on the lever (key 15).
21. Install the control spring (key 32) and upper spring seat (key 33), and apply lubricant to the upper spring seat (key 33).
22. Install the spring case (key 29) so that the screened vent assembly (key 30) is in the correct position for the application. Place the nameplates over the screw holes, insert the spring case cap screws (key 37), and finger tighten.
23. Screw in the adjustment screw to put slack into the diaphragm (key 23).
24. Using a crisscross pattern, finish tightening the spring case cap screws (key 37) to 7 foot-pounds (9,5 N•m) of torque.
25. If necessary, refer to the installation and/or the Startup and Adjustment procedures.
26. Install the adjusting locknut (key 34) after regulator adjustment.

Parts Ordering

When corresponding with your local Sales Office about this equipment, always reference the equipment serial number or FS number that can be found on the nameplate.

627 Series

When ordering replacement parts, reference the key number of each needed part as found in the following parts list. Separate kits containing all recommended spare parts are available.

Parts List

Note

In this parts list, parts marked NACE are intended for corrosion-resistant service as detailed in the NACE International Standard MR0175.

Key	Description	Part Number	Key	Description	Part Number
	Type 627 Parts Kit with Aluminum/Nitrile (NBR) trim (includes keys 4, 9, 11, 12, and 23)	R627X000A12	2*	Orifice Aluminum 3/32-inch (2,4 mm) size	0R044109022
	Type 627 Parts Kit with Stainless steel/Nitrile (NBR) trim (includes keys 4, 9, 11, 12, and 23)	R627X000S12		1/8-inch (3,2 mm) size	1A936709012
	Type 627H Parts Kit with SST/Nylon (PA) trim	R627HX00S12		3/16-inch (4,8 mm) size	00991209012
	Type 627R Parts Kit with Aluminum/Nitrile (NBR) trim (includes keys 4, 9, 11, 12, 23, 28, and 48)	R627RX00A12		1/4-inch (6,4 mm) size	0B042009012
	Type 627R Parts Kit with Stainless steel/Nitrile (NBR) trim (includes keys 4, 9, 11, 12, 23, 28, and 48)	R627RX00S12		3/8-inch (9,5 mm) size	0B042209012
1	Body			1/2-inch (13 mm) size	1A928809012
	Ductile iron			303 Stainless steel	
	1000 psig (69,0 bar) maximum inlet pressure			3/32-inch (2,4 mm) size	0R044135032
	3/4 NPT	30B3046X012		1/8-inch (3,2 mm) size	1A936735032
	1 NPT	30B3048X012		3/16-inch (4,8 mm) size	00991235032
	2 NPT	30B3096X012		1/4-inch (6,4 mm) size	0B042035032
	Ductile iron (NACE)			3/8-inch (9,5 mm) size	0B042235032
	1000 psig (69,0 bar) maximum inlet pressure			1/2-inch (13 mm) size	1A928835032
	1 NPT	39B2451X012		316 Stainless steel, NACE construction only	
	2 NPT	39B0414X012		3/32-inch (2,4 mm) size	0R0441X0012
	Steel			1/8-inch (3,2 mm) size	1A9367X0022
	2000 psig (138 bar) maximum inlet pressure			3/16-inch (4,8 mm) size	009912X0012
	3/4 NPT	30B3050X012		1/4-inch (6,4 mm) size	0B0420X0012
	1 NPT	30B3051X012		3/8-inch (9,5 mm) size	0B0422X0012
	2 NPT	30B7452X012		1/2-inch (13 mm) size	1A9288X0012
	Steel (NACE)		3	Cap Screw (not shown), (2 required) 627 Series	
	2000 psig (138 bar) maximum inlet pressure			For Ductile iron/Steel diaphragm case	1A560724052
	1 NPT	39B0412X012		For Aluminum diaphragm case (not applicable for Types 627H and 627HM)	1A352524052
	2 NPT	39B0415X012		Type 627 Only	
	Steel, CL600 RF flanged			For Ductile iron/Steel diaphragm case	1A5607X0052
	1500 psig (103 bar) maximum inlet pressure			For Aluminum case with Steel diaphragm case	10A3869X012
	NPS 1 (DN 25), CL600 RF	40B6754X012	4*	Diaphragm Case O-ring	
	1500 psig (103 bar) maximum inlet pressure			Nitrile (NBR) For Type 627, 627H, or 627R only	17A2325X022
	NPS 2 (DN 50), CL600 RF	40B6756X012		Fluorocarbon (FKM)	
	Steel, CL300 RF flanged			For Types 627, 627R, and 627LR only	10A0037X012
	750 psig (51,7 bar) maximum inlet pressure		5	Diaphragm Case	
	NPS 1 (DN 25), CL300 RF	41B8978X012		For Type 627, 627R, or 627LR	
	NPS 2 (DN 50), CL300 RF	41B8080X012		Aluminum without 1/8-inch (3,2 mm) gauge tap	40B3084X012
	Steel, CL150 RF flanged			Aluminum with 1/8-inch (3,2 mm) gauge tap for 627 Series (except Types 627H and 627HM)	11B5380X012
	290 psig (20,0 bar) maximum inlet pressure			Ductile iron without 1/8-inch (3,2 mm) gauge tap	30B3053X012
	NPS 1 (DN 25), CL150 RF	43B8656X022		Ductile iron with 1/8-inch (3,2 mm) gauge tap for 627 Series (except Types 627H and 627HM)	31B0641X012
	NPS 2 (DN 50), CL150 RF	44B0666X012		Steel	30B3104X012
	Steel, PN 16/25/40 RF			Ductile iron with 1/4 NPT gauge tap for 627 Series (except Types 627H and 627HM)	39A5987X012
	580 psig (40,0 bar) maximum inlet pressure			Steel with 1/4 NPT gauge tap for 627 Series (except Type 627H)	30B8734X012
	NPS 1 (DN 25)	44B0386X012		For Type 627M or 627MR	
	NPS 2 (DN 50)	44B3342X012		Ductile iron	39A5987X012
				Steel	30B8734X012
				For Type 627H, Steel	30B3104X012
				For Type 627HM, Steel	30B8734X012
			6	Boost Body (not for Type 627M, 627HM, or 627MR), Delrin®	
				For Type 627 or 627H	30B3056X012
				For Type 627R or 627LR	30B3057X012
			7	Stabilizer	
				Nitrile (NBR)	
				For Types 627, 627H, 627R, and 627LR only	10B3060X012
				Fluorocarbon (FKM)	
				For Types 627, 627R, and 627LR only	10B3060X022
			8	Stem Guide (for Types 627, 627H, 627R, and 627LR only), Powdered metal	20B3061X012
			9*	Disk Assembly (for all Orifice Size)	
				Aluminum holder and Nitrile (NBR) disk	1C4248X0212
				303 Stainless steel holder and Nitrile (NBR) disk	1C4248X0202
				Aluminum holder and Nylon (PA) disk	1C4248X00A2

*Recommended spare part.
Delrin® is a mark owned by E.I. du Pont de Nemours and Co.

627 Series

Key	Description	Part Number	Key	Description	Part Number
9*	Disk Assembly (for all Orifice Size) (continued)		28*	Relief Seal O-ring	
	303 Stainless steel holder and Nylon (PA) disk	1C4248X0062		Nitrile (NBR)	
	316 Stainless steel holder and Nylon (PA) disk	1C4248X0262		For Type 627R, 627LR, or 627MR only	1J108506992
	316 Stainless steel holder and Nitrile (NBR) disk	1C4248X0252		Fluorocarbon (FKM)	
	303 Stainless steel holder and Fluorocarbon (FKM) disk	1C4248X0052	29	Spring Case	1J1085X0042
	Aluminum holder and Fluorocarbon (FKM) disk	1C4248X0182		For Type 627, 627R, or 627LR	
	316 Stainless steel holder and Fluorocarbon (FKM) disk	1C4248X0192		Aluminum	40B3086X012
10	Stem			Ductile iron	30B3055X012
	303 Stainless steel	10B3059X012		Steel	30B3102X012
	316 Stainless steel (NACE)	10B3059X022		For Type 627M or 627MR	
11*	Stem O-ring			Ductile iron	30B3055X012
	Nitrile (NBR)	1D687506992		Steel	30B3102X012
	Fluorocarbon (FKM) For Types 627, 627R, 627LR, 627M, and 627MR only	1N430406382		For Type 627H or 627HM	
12*	Stem Backup Ring, Polytetrafluoroethylene (PTFE) (2 required)	1K786806992	30	Screened Vent Assembly, Plastic	30B3102X012
13	Hair Pin Clip, Stainless steel	10B3058X012	31	Lower Spring Seat, Plated steel	10B3093X012
14	Drive Pin, Plated steel	1H3671X0012		For Type 627 or 627M	1D666625072
15	Lever, Plated steel	20B3063X012		For Type 627R, 627LR or 627MR	20B3073X012
16	Lever Retainer, Plated steel	30B3097X012	32	Control Spring, Plated steel	
17	Lever Pin			5 to 20 psig (0,34 to 1,4 bar), Yellow	10B3076X012
	Stainless steel	10B3083X012		15 to 40 psig (1,0 to 2,8 bar), Green	10B3077X012
	316 Stainless steel (NACE)	10B3083X022		35 to 80 psig (2,4 to 5,5 bar), Blue	10B3078X012
18	Lever Cap Screw (2 required)			70 to 150 psig (4,8 to 10,3 bar), Red	10B3079X012
	Plated steel	10B7454X012		Blue, used in a Type 627H or 627HM	10B3078X012
	316 Stainless steel (NACE)	1B2905X0012		240 to 500 psig range (16,5 to 34,5 bar), Red, used in a Type 627H or 627HM	10B3079X012
19	Pusher Post, Aluminum		33	Upper Spring Seat, Plated steel	1D667125072
	For Type 627 or 627M	10B3098X012	34	Locknut, Plated steel	1D667728982
	For Type 627R, 627LR or 627MR	10B3098X022	35	Adjusting Screw, Plated steel	
	For Type 627H or 627HM, 416 Stainless steel	10B3098X032		For Type 627 or 627M	10B3081X012
	Stainless steel (NACE)	10B3098X102		For Type 627H or 627HM	10B3081X012
21	Diaphragm Connector (for Type 627R, 627LR or 627MR only), Stainless steel	28B8832X012		For Type 627R, 627LR or 627MR	10B3080X012
22	Diaphragm Connector Nut (for Type 627R, 627LR or 627MR only), Stainless steel	10B7449X012	36	Adjusting Screw Cap, Plastic	20B3082X012
23*	Diaphragm		37	Spring Case Cap Screw, Plated steel (8 required)	
	Nitrile (NBR)			For aluminum or ductile iron diaphragm case	1A391724052
	For Type 627 or 627M with Aluminum or Ductile iron diaphragm case	10B3069X012		For steel diaphragm case	1A368324052
	For Type 627 or 627M with Steel diaphragm case	10B8735X012		For Type 627H/HM, steel diaphragm case	1A346424052
	For Type 627R, 627LR, or 627MR with Aluminum or Ductile iron diaphragm case	10B3068X012	43	Blocked Throat (For Type 627M, 627HM, or 627MR only), Stainless steel	10B3085X012
	For Type 627R, 627LR, or 627MR with Steel diaphragm case	10B8736X012	44*	Blocked Throat O-ring	
	For Type 627H or 627HM with Steel diaphragm case (diaphragm is Neoprene (CR) with Nylon (PA) fabric)	12B0178X012		Nitrile (NBR) For for Type 627M, 627HM, or 627MR only (2 required)	1E264306992
	Fluorocarbon (FKM)			Fluorocarbon (FKM)	
	For Types 627R, 627LR, and 627MR with Steel case	10B8736X022		For Types 627M and 627MR only	1E2643X0022
	For Types 627 and 627M with Steel case	10B8735X042	45*	Blocked Throat Backup Ring (For Type 627M, 627HM, or 627MR only), PTFE (2 required)	10B3106X012
	For Types 627R, 627LR, and 627MR with Ductile Iron and Aluminum Casing	10B3068X022	46	Diaphragm Head Cap Screw, Steel	
	For Types 627 and 627M with Ductile Iron and Aluminum Casing	10B3069X032		For Type 627 or 627M	1B290524052
24	Diaphragm Head, Plated steel			For Type 627H or 627HM	1C379124052
	For Type 627 or 627M, Plated steel	1D666428982	47	Relief Seal Retainer (For Type 627R, 627LR or 627MR only), Stainless steel	10B7445X012
	For Type 627R, 627LR or 627MR, Plated steel	10B3071X012	48*	Guide Retainer O-ring	
	For Type 627H or 627HM, 416 Stainless steel	12B0175X012		Nitrile (NBR)	
25	Relief Spring Seat (For Type 627R or 627MR only), Steel	10B7446X012		For Type 627R, 627LR, or 627MR only	1D682506992
26	Guide Retainer (For Type 627R, 627LR or 627MR only), Stainless steel	10B7450X012		Fluorocarbon (FKM)	
27	Relief Spring (For Type 627R or 627MR only), Plated steel	10B6757X012		For Types 627R, 627LR, and 627MR only	1N423906382
	For Type 627LR	1B541327022	49	Relief Indicator (For Type 627R, 627LR or 627MR only), Rubber (not shown)	30B3100X012
			50	Diaphragm Limiter (For Types 627H and 627HM only)	22B0176X012
			51*	Diaphragm Limiter O-ring	
				For Types 627H and 627HM only	1K877606992
			52*	Pusher Post O-ring (2 required)	
				For Types 627H and 627HM only	1C853806992
			58	Pipe Plug, Zinc	1D8293T0022
			67	Drive Screw, 18-8 Stainless steel	1A368228982
			72	Pipe Plug, Zinc-plated steel	1A767524662

*Recommended spare part.

627 Series

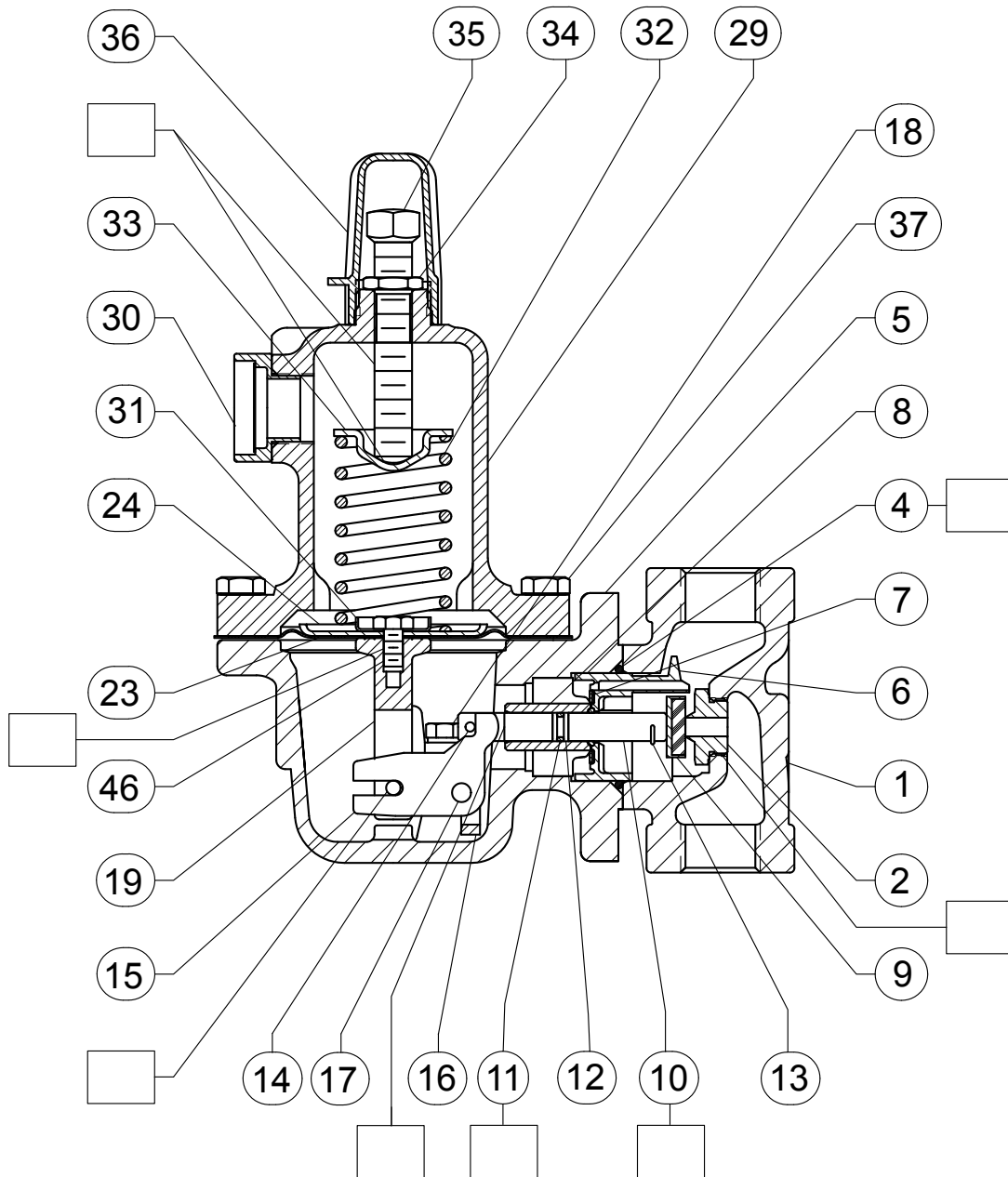

30B3092_G
 APPLY LUBRICANT
 PARTS NOT SHOWN: 3

Figure 7. Type 627 Regulator Assembly

*Recommended spare part.

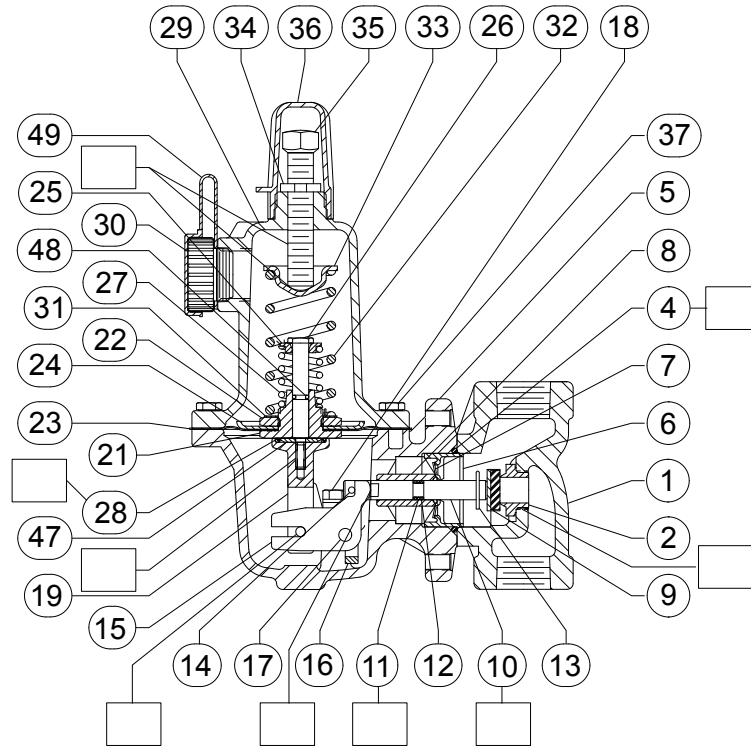

Figure 8. Type 627R Regulator Assembly

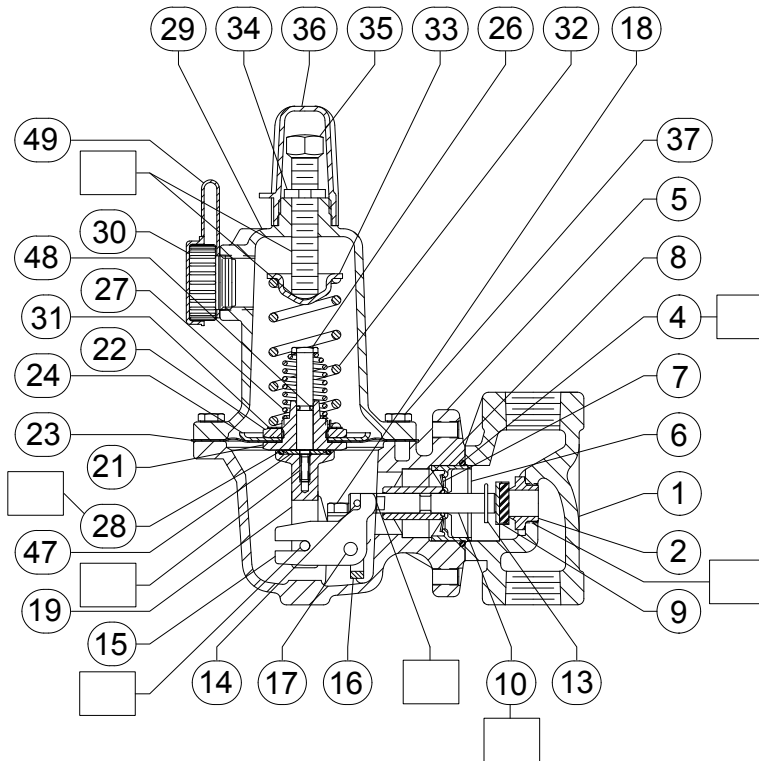

Figure 9. Type 627LR Regulator Assembly

30B3089_G

38B4843_C

□ APPLY LUBRICANT
PARTS NOT SHOWN: 3

627 Series

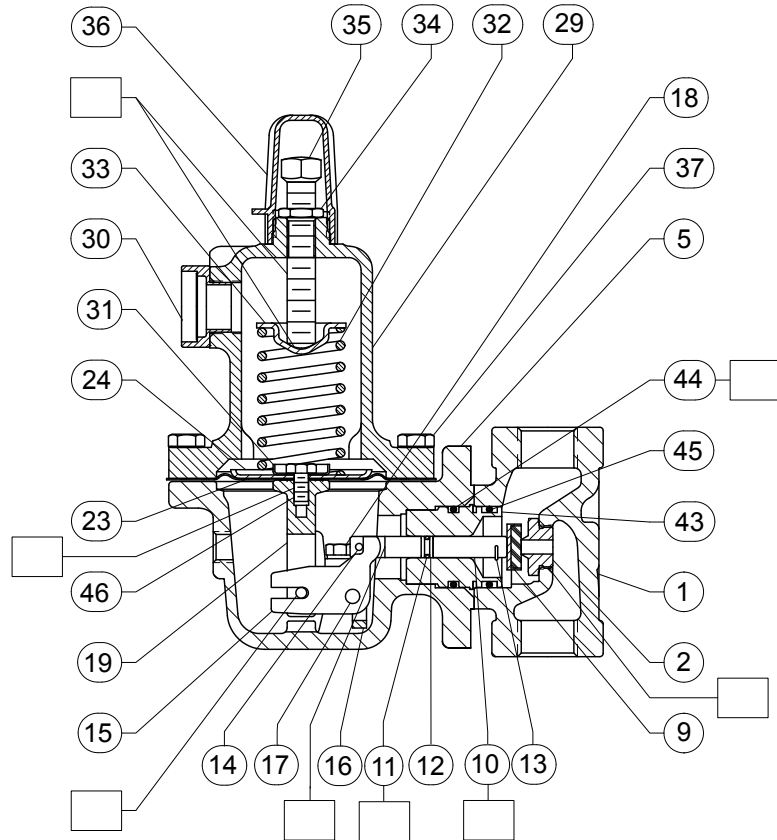

30B6433_E

Figure 10. Type 627M Regulator Assembly

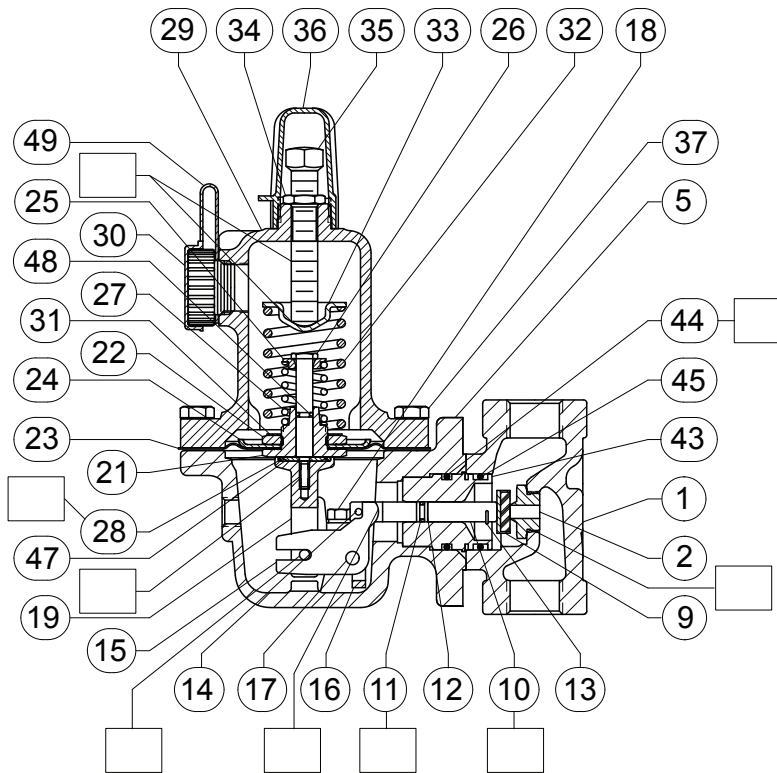

30B6434_E

□ APPLY LUBRICANT
PARTS NOT SHOWN: 3

Figure 11. Type 627MR Regulator Assembly

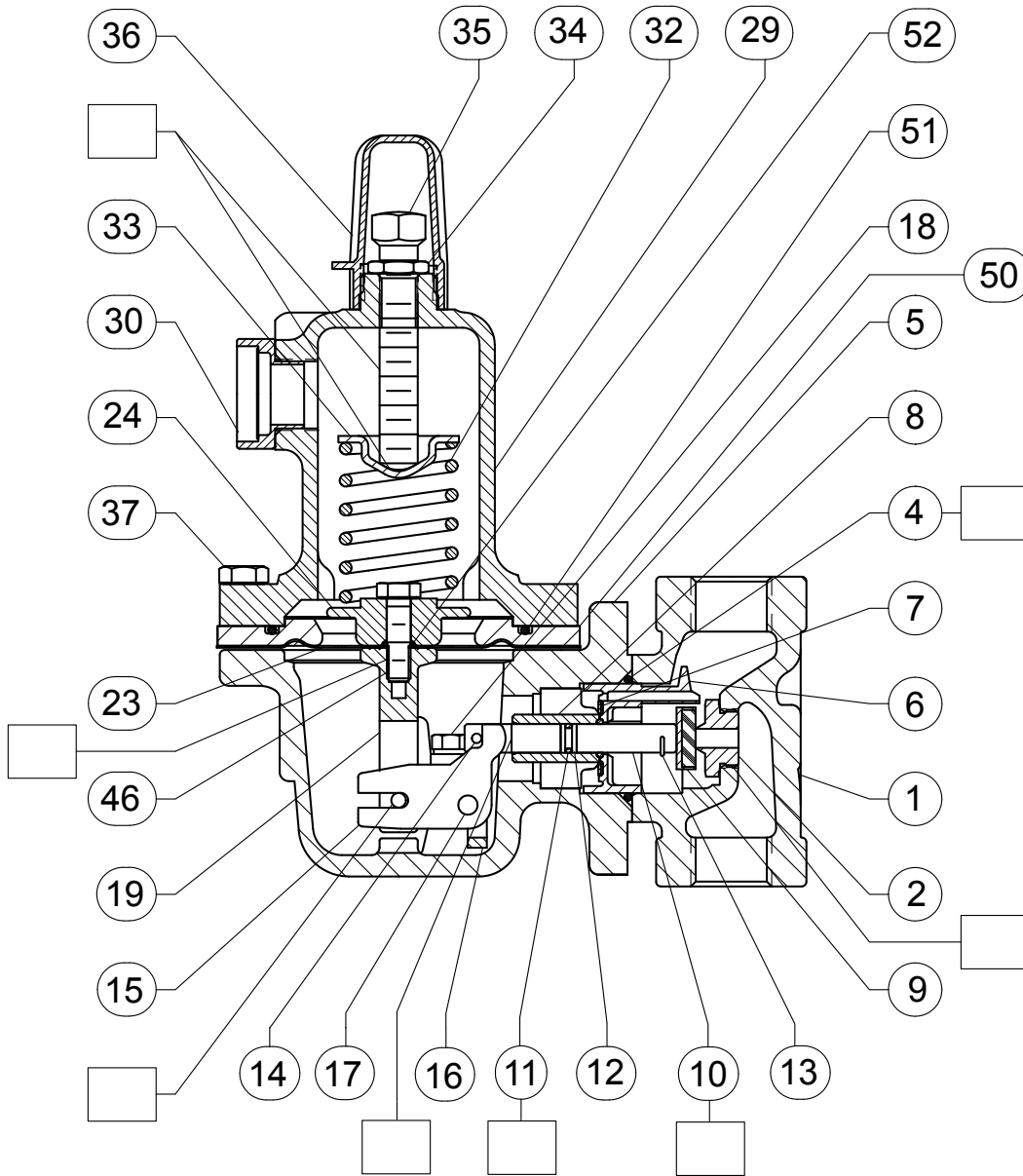

31B5374_D

□ APPLY LUBRICANT
 PARTS NOT SHOWN: 3

Figure 12. Type 627H Regulator Assembly

627 Series

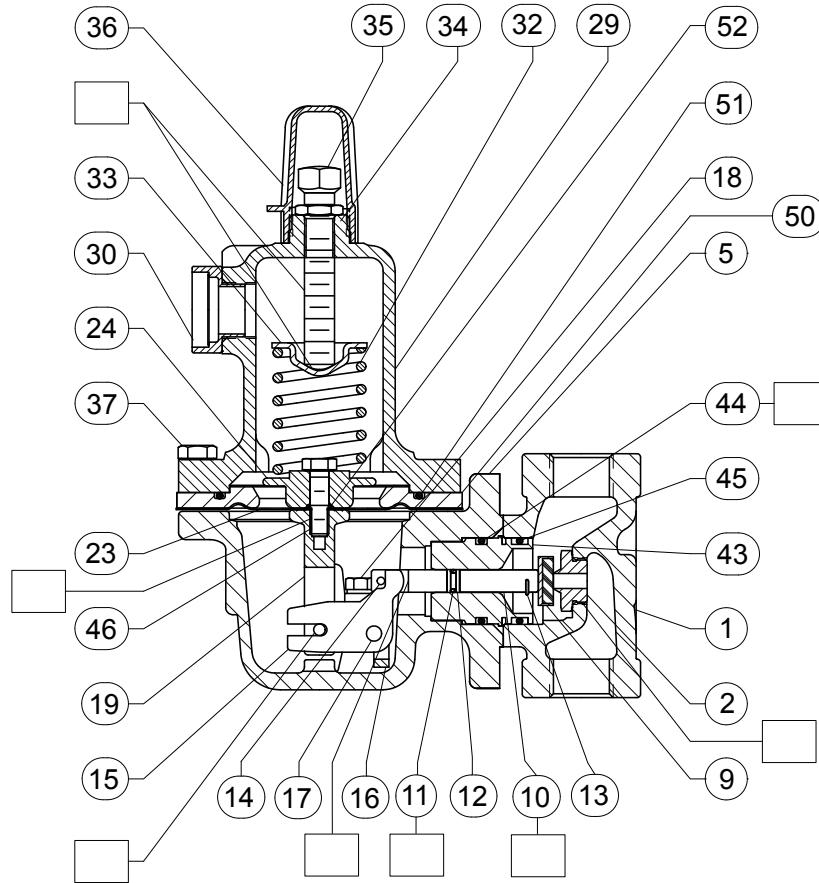

31B9872_D

□ APPLY LUBRICANT
PARTS NOT SHOWN: 3

Figure 13. Type 627HM Regulator Assembly

Industrial Regulators

Emerson Process Management Regulator Technologies, Inc.

USA - Headquarters
McKinney, Texas 75069-1872 USA
Tel: 1-800-558-5853
Outside U.S. 1-972-548-3574

Asia-Pacific
Shanghai, China 201206
Tel: +86 21 2892 9000

Europe
Bologna, Italy 40013
Tel: +39 051 4190611

Middle East and Africa
Dubai, United Arab Emirates
Tel: +971 4811 8100

Natural Gas Technologies

Emerson Process Management Regulator Technologies, Inc.

USA - Headquarters
McKinney, Texas 75069-1872 USA
Tel: 1-800-558-5853
Outside U.S. 1-972-548-3574

Asia-Pacific
Singapore, Singapore 128461
Tel: +65 6777 8211

Europe
Bologna, Italy 40013
Tel: +39 051 4190611
Gallardon, France 28320
Tel: +33 (0)2 37 33 47 00

TESCOM

Emerson Process Management Tescom Corporation

USA - Headquarters
Elk River, Minnesota 55330-2445 USA
Tel: 1-763-241-3238

Europe
Selmsdorf, Germany 23923
Tel: +49 (0) 38823 31 0

For further information visit www.fisherregulators.com

The Emerson logo is a trademark and service mark of Emerson Electric Co. All other marks are the property of their prospective owners. Fisher is a mark owned by Fisher Controls, Inc., a business of Emerson Process Management.

The contents of this publication are presented for informational purposes only, and while every effort has been made to ensure their accuracy, they are not to be construed as warranties or guarantees, express or implied, regarding the products or services described herein or their use or applicability. We reserve the right to modify or improve the designs or specifications of such products at any time without notice.

Emerson Process Management does not assume responsibility for the selection, use or maintenance of any product. Responsibility for proper selection, use and maintenance of any Emerson Process Management product remains solely with the purchaser.