

# R122H, R222H, R222, R232A and R232E Series Instruction Manual

## ! WARNING

Failure to follow these instructions or to properly install and maintain this equipment could result in an explosion and/or fire causing property damage and personal injury or death.

Fisher® equipment must be installed, operated and maintained in accordance with federal, state and local codes and Fisher instructions. The installation in most states must also comply with NFPA No. 54 and 58 standards.

Only personnel trained in the proper procedures, codes, standards and regulations of the LP-Gas industry should install and service this equipment.

### Things to tell the gas customer:

1. Show the customer the vent or vent assembly or vent tube. Stress that this opening must remain unobstructed at all times. Tell the customer to check the vent opening after a freezing rain, sleet storm or snow to make sure ice has not formed in the vent.
2. Show the customer the shutoff valve on the container. The customer should close this valve immediately if gas is smelled, appliance pilot lights fail to stay on or appear higher than usual or any other abnormal situation occurs.
3. Tell the customer to call your company to service the regulator if the regulator vents gas or a leak develops in the system. Only a qualified gas service person should install or service the regulator.
4. Tell the customer to call your company to have a leak check performed if the gas supply has been shutoff or interrupted for any reason. A leak check must be performed by a qualified gas service person on the piping system immediately after turning on the gas supply.



*Figure 1. R122H, R222H, R222, R232A and R232E Series Regulators*

## Introduction

### Scope of the Manual

This Instruction Manual covers installation and maintenance for the R122H, R222H, R222, R232A and R232E Series regulators, which includes first stage, second stage, integral two-stage and integral two psig service regulators used on LP-Gas vapor service applications. They are not to be used on liquid service.

## Specifications

Specifications and Tables 1 and 2 list the specifications for these regulators. Contact the factory if the regulator is to be used on any service other than LP-Gas, natural gas or air. The following information is located on the spring case: type number, orifice size, spring range and date of manufacture.

### Pressure Taps Size Restriction

**1/8 NPT:** #54 / 0.055 in. Drill on outlet and inlet

### Orifice Sizes

**R122H Series:** 0.15 in. / 3.8 mm

**R222 Series:** 0.14 in. / 3.6 mm

**R232A, R232E and R222H Series:** 0.193 in. / 4.9 mm

### Wide Open C<sub>g</sub> for Relief Sizing

**R122H Series:** 23

**R222 Series:** 18

**R232A and R232E Series:** 19

**R222H Series:** 37

### Maximum Allowable Inlet Pressure

**R122H, R222H, R232A and R232E Series:**

250 psig / 17.2 bar

**R222 Series:** 10 psi / 0.69 bar

### Maximum Emergency Inlet Pressure

**R122H, R222H, R232A and R232E Series:**

250 psig / 17.2 bar

**R222 Series<sup>(1)</sup>:** 75 psi / 5.2 bar when used with a Fisher® Types R122H, R222H or R622H first stage regulator. 40 psi / 2.8 bar when used with any other first stage regulator.

### Temperature Capabilities

**R122H, R222H, R222, R232A and R232E Series:**

-20 to 160°F / -29 to 71°C<sup>(2)</sup>

### Pressure Registration

Internal

### Outlet Pressure Standard Setpoint

**R222H Series:** 10 psi / 0.69 bar or 5 psi / 0.35 bar

**R122H Series:** 10 psi / 0.69 bar

**R222 Series: Second Stage:** 11 in. w.c. / 27 mbar

**R232A Series: First Stage:** approximately 9 psig / 0.62 bar at 100 psig / 6.9 bar, 50 SCFH / 1.42 Nm<sup>3</sup>/h  
**Second Stage:** 11 in. w.c. / 27 mbar

**R232E Series: First Stage:** 9 psig / 0.62 bar at 100 psig / 6.9 bar, 50 SCFH / 1.42 Nm<sup>3</sup>/h

**Second Stage:** 2 psig / 0.14 bar

### Outlet Pressure Spring Ranges

**R222H Series:** 8 to 11.9 psig / 0.55 to 0.82 bar or 4 to 6 psig / 0.28 to 0.41 bar

**R122H Series:** 10 psig / 0.69 bar +/- 1 psig / 0.07 bar (non-adjustable)

**R222 Series: Second Stage:** 9.5 to 13 in. w.c. / 24 to 32 mbar

**R232A Series: First Stage:** non-adjustable  
**Second Stage:** 10.2 to 13 in. w.c. / 25 to 32 mbar

**R232E Series: First Stage:** non-adjustable  
**Second Stage:** 1 to 2.2 psig / 0.07 to 0.15 bar

### Approximate Weights

**R222H Series with POL:** 2.12 lbs / 961.8 g

**R222H Series with NPT fitting:** 1.73 lbs / 784.8 g

**R122H Series:** 1.2 lbs / 544 g

**R222 Series:** 1.4 lbs / 635 g

**R232A and R232E Series with POL:**

1.9 lbs / 865 g

**R232A and R232E Series with NPT fitting:**

1.5 lbs / 671 g

1. In the event the R222 Series malfunctions during a Maximum Emergency Inlet Pressure condition these inlet pressures and the R222 Series relief performance will limit downstream pressure to 2 psi / 0.14 bar or less.  
 2. Product has passed Fisher testing for lockup, relief start-to-discharge and reseal down to -40°F / -40°C.

## Description

### Second Stage Low Pressure Regulator

The Type R222 second stage regulator provides low pressure, inches of water column, delivery pressure. It is set at 11 in. w.c. / 27 mbar pressure and comes with a high capacity internal relief valve. The regulators are painted PALM GREEN.

### Integral Two-stage Regulator

The Type R232A integral two-stage regulator contains a non-adjustable first stage regulator on the inlet. The second stage provides 11 in. w.c. / 27 mbar outlet pressure. The second stage portion has a high capacity internal relief valve construction. The first stage does not have an internal relief valve. The regulators are painted GRAY with a BLACK CAP.

### Integral Two psig Service Regulator

The Type R232E integral two psig service regulator contains a non-adjustable first stage regulator on the inlet. The second stage provides 2 psig / 0.14 bar outlet pressure. The second stage portion has a high capacity internal relief valve construction. The first stage does not have an internal relief valve. The regulators are painted GRAY with a WHITE CAP.

### First Stage Regulators

Types R122H and R222H regulators are designed for high pressure (pounds per square inch) vapor service. These regulators have high capacity internal relief valves.

When used on first stage service, the Type R122H regulator reduces container pressure to approximately 10 psig / 0.69 bar inlet pressure to a second stage regulator. The Type R222H regulator reduces container pressure to

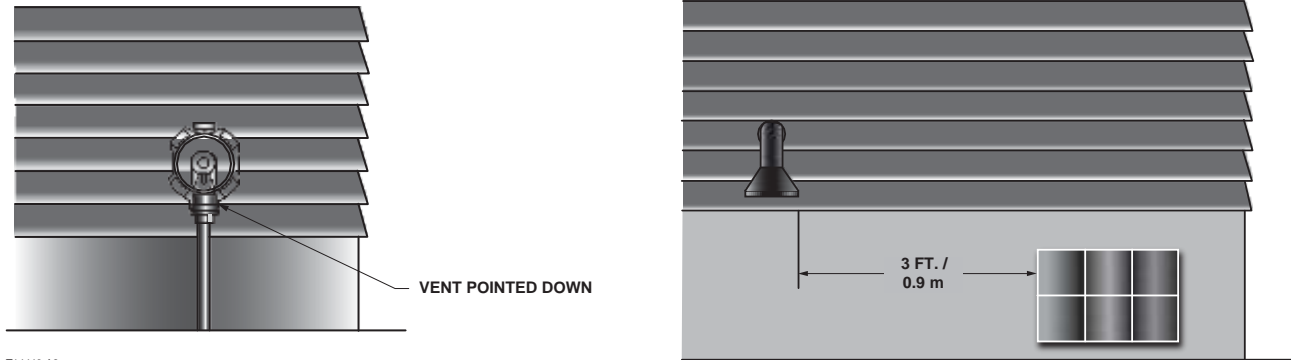

T14446-A2

**Figure 2. Regulator with Vent Pointed Down**

**Table 1. Relief Valve Specifications**

| TYPE                 | TYPICAL SETPOINT |         | NOMINAL RELIEF VALVE START-TO-DISCHARGE |      | MAXIMUM OUTLET PRESSURE WITH DISC REMOVED |      |                         |      |
|----------------------|------------------|---------|---|------|---|------|-------------------------|------|
|                      | psi              | bar     | psi                                     | bar  | Inlet Pressure                            |      | Maximum Outlet Pressure |      |
|                      |                  |         |   |      | psig                                      | bar  | psig                    | bar  |
| R122H                | 10               | 0.69    | 16                                      | 1.10 | 250                                       | 17.2 | Not Applicable          |      |
| R222H                | 5                | 0.35    | 9                                       | 0.62 | 250                                       | 17.2 | Not Applicable          |      |
|                      | 10               | 0.69    | 16                                      | 1.10 |   |      |                         |      |
| R222                 | 11 in. w.c.      | 27 mbar | 1                                       | 0.07 | 30  | 2.07 | 2.0                     | 0.14 |
| R232A <sup>(1)</sup> | 11 in. w.c.      | 27 mbar | 1                                       | 0.07 | 250                                       | 17.2 | 2.0                     | 0.14 |
| R232E <sup>(1)</sup> | 2                | 0.14    | 3.5                                     | 0.24 |   |      | 5.0                     | 0.35 |

1. For integral two-stage regulators, the second stage disc is removed.

**Table 2. Capacity, Connection Sizes and Vent Orientation**

| REGULATOR APPLICATION     | TYPE NUMBER | CAPACITY BTU/HR PROPANE <sup>(1)</sup> | INLET CONNECTION | OUTLET CONNECTION | OUTLET PRESSURE SETTING | 3/8 IN. FNPT SCREENED VENT STANDARD LOCATION                   |   |
|---------------------------|-------------|--|------------------|-------------------|-------------------------|--|---|
| First Stage               | R122H-AAJ   | 1,100,000                              | 1/4 in. FNPT     | 1/2 in. FNPT      | 10 psig / 0.69 bar      | Over Outlet <sup>(2)</sup>                                     |   |
| First Stage               | R222H-BGK   | 1,700,000                              | 1/2 in. FNPT     | 1/2 in. FNPT      | 5 psig / 0.35 bar       | Over Outlet  |   |
|                           | R222H-DGK   | 2,000,000                              | 3/4 in. FNPT     | 3/4 in. FNPT      |                         |  |   |
|                           | R222H-HGK   | 1,700,000                              | FPOL             | 1/2 in. FNPT      |                         |  |   |
|                           | R222H-JGK   | 1,875,000                              | FPOL             | 3/4 in. FNPT      |                         |  |   |
|                           | R222H-BGJ   | 1,800,000                              | 1/2 in. FNPT     | 1/2 in. FNPT      | 10 psig / 0.69 bar      |  |   |
|                           | R222H-DGJ   | 2,000,000                              | 3/4 in. FNPT     | 3/4 in. FNPT      |                         |  |   |
|                           | R222H-HGJ   | 1,800,000                              | FPOL             | 1/2 in. FNPT      |                         |  |   |
|                           | R222H-JGJ   | 1,875,000                              | FPOL             | 3/4 in. FNPT      |                         |  |   |
| Second Stage              | R222-BAF    | 650,000                                | 1/2 in. FNPT     | 1/2 in. FNPT      | 11 in. w.c. / 27 mbar   | Over Inlet   |   |
|                           | R222-BAFXA  |  |                  |                   |                         | Over Outlet  |   |
| Integral Two-Stage        | R232A-BBF   | 550,000                                | 1/4 in. FNPT     | 1/2 in. FNPT      |                         | First Stage <sup>(3)</sup> : Down<br>Second Stage: Over Outlet |   |
|                           | R232A-HBF   |  | FPOL             |                   |                         |  |   |
|                           | R232A-BBFXA | 550,000                                | 1/4 in. FNPT     | 1/2 in. FNPT      |                         |  | First Stage: Opposite Gauge Taps<br>Second Stage: Opposite Gauge Taps |
|                           | R232A-HBFXA |  | FPOL             |                   |                         |  |   |
| Integral Two psig Service | R232E-BBH   | 500,000                                | 1/4 in. FNPT     | 1/2 in. FNPT      | 2 psig / 0.14 bar       | First Stage <sup>(3)</sup> : Down<br>Second Stage: Over Outlet |   |
|                           | R232E-HBH   |  | FPOL             |                   |                         |  |   |

1. Capacities Based on:  
 Second Stage: 10 psig / 0.69 bar with 2 in. w.c. / 5 mbar droop.  
 Integral Two Stage: 30 psig / 2.07 bar and 2 in. w.c. / 5 mbar droop.  
 Integral Two psig Service Regulator: 30 psig / 2.07 bar inlet pressure and 20% droop.  
 First Stage: 30 psig / 2.07 bar inlet pressure and 20% droop.  
 2. Also available with vent opposite gauge taps.  
 3. Integral First Stage Vent size: 7/16-24 UN thread for 1/4 in. OD copper tube inverted flare fitting.

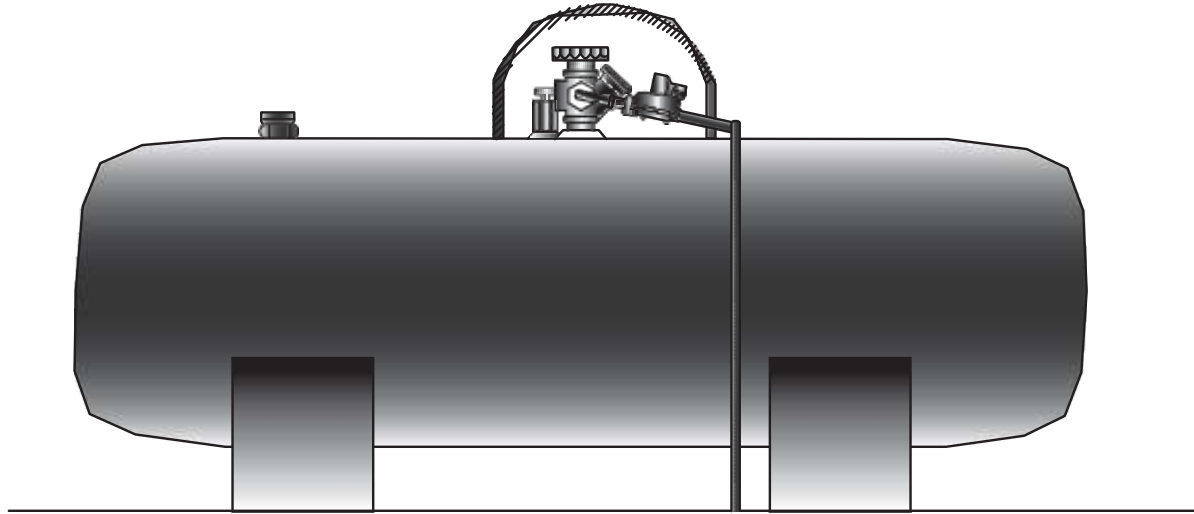

T14447-A2

**Figure 3. Tank Installation**

approximately 10 psig / 0.69 bar or 5 psig / 0.35 bar inlet pressure to a second stage regulator. On final stage service the regulator reduces container pressure for a high pressure burner. The regulator is painted RED.

## Installation

### **! WARNING**

**All vents should be kept open to permit free flow of air in and out of the regulator. Protect vent openings against the entrance of rain, snow, ice formation, paint, mud, insects, water from an irrigation system or any other foreign material that could plug the vent or vent line or accumulate in the vent line.**

**LP-Gas may discharge to the atmosphere through the vent. An obstructed vent which limits air or gas flow can cause abnormally high pressure that could result in personal injury or property damage.**

**The Types R232A, R232E, R122H and R222H are not suitable for indoor installations. Failure to use a vent line with Type R222 second stage regulators in indoor applications can cause a hazardous accumulation of gas which could result in personal injury or property damage.**

**Never use the Types R122H, R222H and R232E (pounds-to-pounds) regulators on low pressure (inches of water column) service because personal injury or property damage could occur.**

## General Installation Instructions

Before installing the regulator,

- Check for damage, which might have occurred in shipment.
- Check for and remove any dirt or foreign material, which may have accumulated in the regulator body.
- Replace old pigtails. Blow out any debris, dirt or copper sulfate in the copper tubing and the pipeline.
- Apply pipe compound to the male threads of the pipe before installing the regulator.
- Make sure gas flow through the regulator is in the same direction as the arrow on the body. “Inlet” and “Outlet” connections are clearly marked.

## Installation Location

- The installed regulator should be adequately protected from vehicular traffic and damage from other external sources.
- Install the regulator with the vent pointed vertically down, see Figure 2. If the vent cannot be installed in a vertically down position, the regulator must be installed under a separate protective cover. Installing the regulator with the vent down allows condensation to drain, minimizes the entry of water or other debris from entering the vent and minimizes vent blockage from freezing precipitation.
- Do not install the regulator in a location where there can be excessive water accumulation or ice formation, such as directly beneath a down spout, gutter or roof line of building. Even a protective hood may not provide adequate protection in these instances.

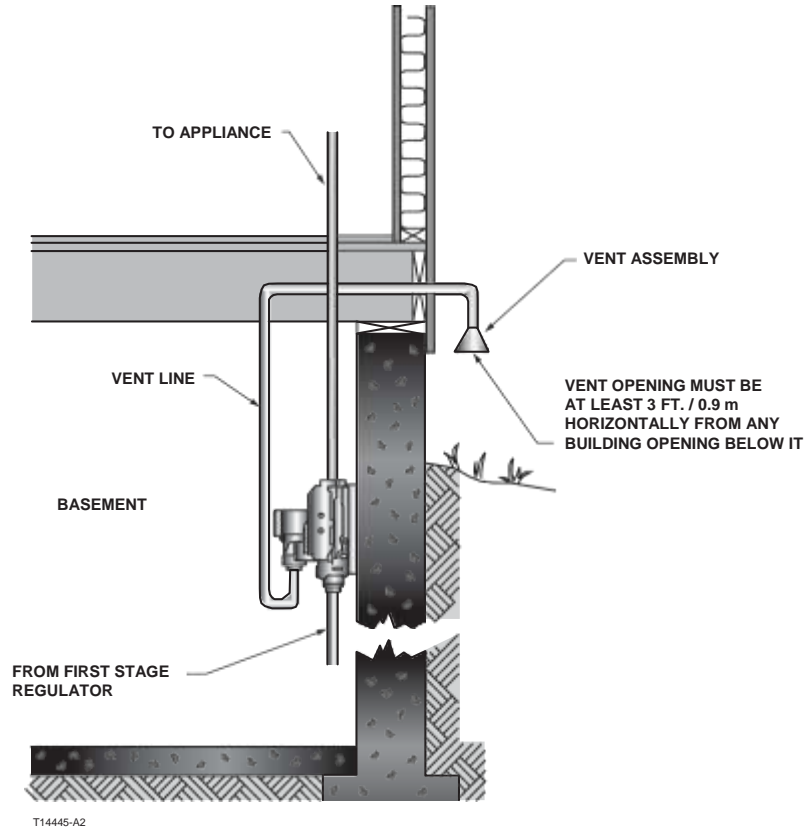

Figure 4. Basement Installation

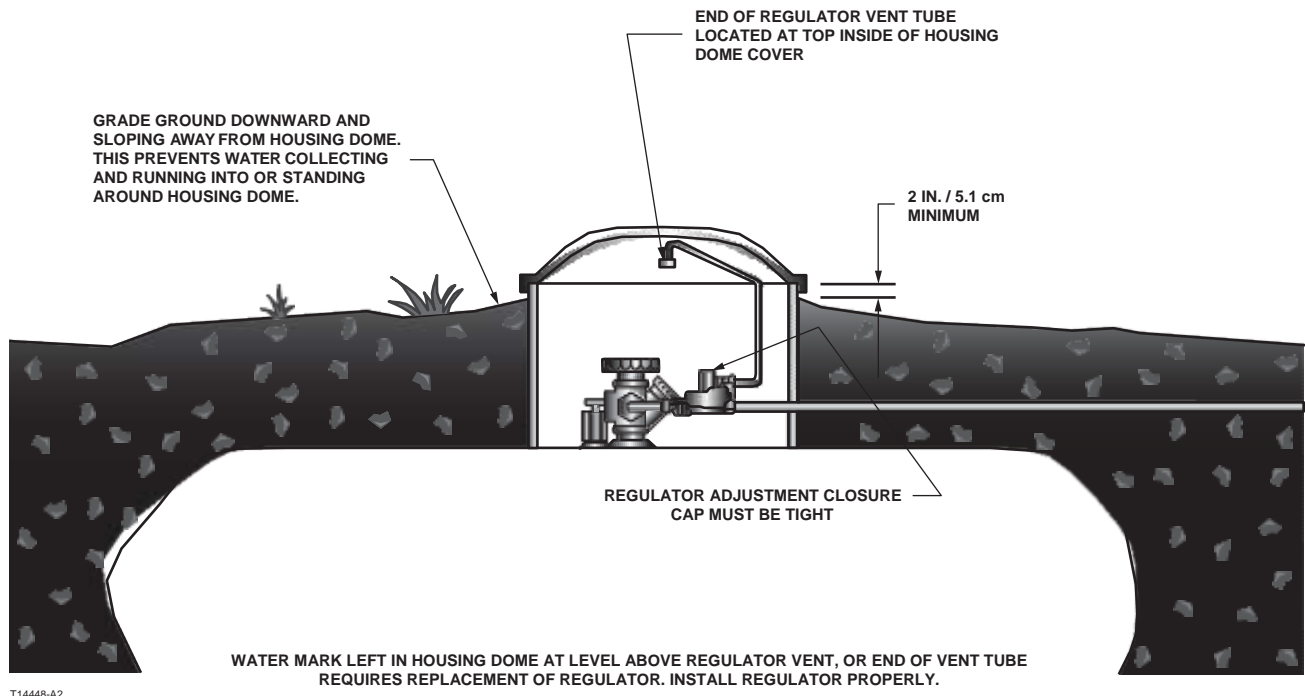

Figure 5. Underground Installation

- Install the regulator so that any gas discharge through the vent or vent assembly is over 3 ft. / 0.9 m horizontally from any building opening below the level of discharge.
- Install the regulator high enough above ground level - at least 18 in. / 46 cm - so that rain splatter cannot freeze in the vent.

## Regulators Subjected to Heavy Snow Conditions

Some installations, such as in areas with heavy snowfall, may require a hood or enclosure to protect the regulator from snow load and vent freeze over.

## Horizontally Installed Regulators

Horizontally mounted regulators, such as found in single cylinder installations and ASME tanks, must be installed beneath a protective cover or under the ASME tank dome, refer to Figure 3. If possible, slope or turn the vent down sufficiently to allow any condensation to drain out of the spring case. Be careful that the slot in the tank dome or protective cover for the regulator's outlet piping does not expose the vent to the elements. The first stage vent on the Types R232A and R232E should be pointed down.

## Indoor Installations

The Types R122H, R222H, R232A and R232E regulators are not recommended for indoor installations. The Type R222 regulator may be installed indoors as follows.

By code, regulators installed indoors have limited inlet pressure and they require a vent line to the outside of the building, see Figure 4. A vent assembly, such as Fisher® Y602 Series, should be used on the end of the vent line. The same installation precautions, previously discussed throughout this manual for the regulator vent, apply to the end of the vent tube assembly. Vent lines must not restrict the gas flow from the regulator's internal relief valve. Vent lines should be at least 3/4 in. NPT pipe or 3/4 in. NPT size, Gray PVC Schedule 40 Rigid Non-metallic Electrical Conduit for above Ground Service, per UL® 651. To install the vent line, remove the vent screen and apply a good grade of pipe dope to the male threads of the line. Vent lines should be as straight as possible with a minimum number of bends.

## Underground Installations

### ! WARNING

**Types R232A and R232E integral regulators require 2 vent tubes, one on the first stage vent and one on the second stage vent, when installed on underground tanks.**

### **Failure to use 2 separate vent tubes can result in early regulator failure and/or over pressuring the second stage that could result in fires or personal injury.**

A regulator installed in the dome of an underground container requires a vent tube to prevent water from entering the regulator spring case, see Figure 5.

The Types R122H and R222H will require one vent line and if the Types R232A and R232E integral regulators is installed on an underground tank the use of 2 vent tubes are required, one for the first stage vent (1/4 in. OD copper tube inverted flare connection: 7/16-24 UN thread) and the other for the second stage vent (3/8 NPT) of the regulator, are required.

Remove the vent screen(s) and install vent tube(s). The vent tube must be run from the regulator vent(s) to above the maximum water table. The vent tube opening(s) must terminate at the extreme top inside of the dome cover. Make sure the regulator's closing cap is on tightly and maintain drainage away from the dome at all times.

## Outdoor Installations with Underground Vent Lines

When installed per code, the underground vent line must not restrict the gas flow from the regulator's internal relief valve and must remain clear of debris, dry and fully open at all times. Joints in the vent line must be fully sealed to prevent moisture intrusion into the vent line. A vent assembly, such as the Fisher Y602 Series, should be used on the end of the vent line to prevent entry of precipitation, water or other debris. When underground vent lines are used in humid environments, the vent line must be designed to allow for proper drainage of any collected moisture or condensation.

## Adjustment

Each regulator is factory set. If it becomes necessary to increase the outlet pressure, remove the closing cap and turn the adjustment screw clockwise. Turn the adjusting screw counterclockwise to decrease the outlet pressure. The first stage portion of the Types R232A and R232E integral regulators is non-adjustable.

The inlet and outlet pressure tap plugs on the R122H, R222H, R222, R232A and R232E Series regulators may be removed using a 7/16 in. / 11 mm hexagon wrench. The pressure tap is restricted, so the plug can be removed with pressure in the regulator. Install a pressure gauge to determine the regulator's inlet pressure and outlet setting during adjustment, (Actual pressure at the second stage regulator may be less due to line loss.). After setting, add thread sealant to the 1/8 in. NPT pipe plug. Reinstall the pipe plug by threading it into the gauge port finger-tight and then wrench tighten the plug 1-1/2 to 3 turns past finger tight (approximate maximum torque of 12 ft-lbs / 16 N•m). Replace the closing cap. Check the plug for leakage.

## Overpressure Protection

### ! WARNING

Some type of overpressure protection is needed if actual inlet pressure can exceed the outlet pressure rating. Overpressuring any portion of this equipment above the limits shown in the Specifications may cause damage to regulator parts, leaks in the regulator or personal injury due to bursting of pressure-containing parts or explosion of accumulated gas.

If any portion of the regulator is exposed to an overpressure condition that exceeds the limits in the Specifications, it must be inspected for damage that may have occurred.

Large volumes of gas may discharge through the regulator vent during internal relief valve operation, which can, if not controlled, result in fire or explosion from accumulated gas.

The R122H, R222H, R222, R232A and R232E Series regulators, except for the first stage of the Types R232A and R232E, contain internal relief valves. The internal relief valve in all units will give overpressure protection against excessive build-up resulting from seat leakage due to worn parts or chips or foreign material on the orifice. The amount of internal relief protection provided varies with the regulator type and the cause for the overpressure relief valve operation, see Table 1. When the internal relief valve opens, gas escapes to the atmosphere through the regulator's vent.

Some type of additional external overpressure protection must be provided if the outlet pressure in an overpressure condition exceeds the inlet pressure rating of the gas system or downstream equipment. Common methods of external overpressure protection include relief valves, monitoring regulators, shutoff devices and series regulation.

## Maintenance

### ! WARNING

To avoid personal injury or equipment damage, do not attempt any maintenance or disassembly without first isolating the regulator from system pressure and relieving all internal pressure.

Regulators that have been disassembled for repair must be tested for proper operation before being returned to service. Only parts manufactured by Fisher® should be used for repairing Fisher regulators. Relight pilot lights according to normal startup procedures.

Due to normal wear or damage that may occur from external sources, these regulators must be inspected and maintained periodically. The frequency of inspection and replacement of the regulators depends upon the severity of service conditions or the requirements of local, state and federal regulations. Even under ideal conditions, these regulators should be replaced after 20 years from date of manufacture or sooner should inspection reveal the need.

### Visually inspect the regulator each time a gas delivery is made for:

- Improper installation, vent not pointed vertically down or under a cover; no vent tube on underground systems
- Plugged or frozen vent
- Wrong regulator or no regulator in the system
- Internal or external corrosion, including paint chipping or flaking
- Flooded Regulator; water in spring case; regulator submersed on underground tanks
- Regulator age
- Any other condition that could cause the uncontrolled escape of gas

Failure to do the above could result in personal injury or property damage.

### Vent Opening

Make sure the regulator vent, vent assembly or vent tube does not become plugged by mud, insects, ice, snow, paint, etc. The vent screen aids in keeping the vent from becoming plugged and the screen should be clean and properly installed. Make sure any irrigation system operated near a regulator or vent line does not spray water into the vent opening of the regulator or vent assembly.

### Water inside Regulators from Floods, Weather or Water Table on Underground Systems

Replace any regulator that had water in their spring case, has been flooded, has been submersed below the water table of an underground tank or shows evidence of external or internal corrosion. Checking for internal

corrosion on the Type R222H/R222 and the second stage portions of the Types R232A and R232E can be done by removing the closing cap and with the aid of a flashlight observing the condition of the relief valve spring, main spring and internal spring barrel area. A more detailed examination will require shutting down the gas system and the complete removal of the adjusting screw. The Type R122H regulator must be completely disassembled by a qualified person to look for internal corrosion. Closely examine regulators installed with their vent horizontal for signs of corrosion. Correct any improper installations.

## Regulator Replacement

Older regulators are more likely to catastrophically fail because of worn or corroded parts. Replace R122H, R222H, R222, R232A and R232E Series regulators over 20 years of age. Other service or environmental conditions may dictate replacement of the regulator before it becomes 20 years old. Regulators that are installed in corrosive environments including but not limited to the following conditions should be inspected annually for visual indication of external or internal corrosion and paint chipping or flaking. Regulators in these applications may require replacement sooner and must be replaced if corrosion is evident:

- Regulators that are installed in areas subject to sea salt (coastal) atmosphere
- Regulators that are installed on underground systems
- Regulators installed with underground vent piping
- Regulators that are used in installations where the gas system is only operated and pressurized intermittently

Refer to Fisher® Bulletin LP-32 for additional information.

## Regulator Repair

Regulators that have been disassembled for repair must be tested for proper operation before being returned to service. Only parts manufactured by Fisher should be used to repair Fisher regulators. Be sure to give the complete type number of the regulator when corresponding with the factory.

The type number, orifice size and spring range are on a label attached to the spring barrel. The date of manufacture is stamped on the regulator. Always provide this information in any correspondence with your Fisher Distributor regarding replacement parts or technical assistance. If construction changes are made in the field, be sure that the regulator marking is also changed to reflect the most recent construction.

### LPG Equipment

#### Emerson Process Management Regulator Technologies, Inc.

For further information visit [www.fisherregulators.com](http://www.fisherregulators.com)

The Emerson logo is a trademark and service mark of Emerson Electric Co. All other marks are the property of their prospective owners. Fisher is a mark owned by Fisher Controls International LLC, a business of Emerson Process Management.

*The contents of this publication are presented for informational purposes only, and while every effort has been made to ensure their accuracy, they are not to be construed as warranties or guarantees, express or implied, regarding the products or services described herein or their use or applicability. We reserve the right to modify or improve the designs or specifications of such products at any time without notice.*

Emerson Process Management Regulator Technologies, Inc. does not assume responsibility for the selection, use or maintenance of any product. Responsibility for proper selection, use and maintenance of any Emerson Process Management Regulator Technologies, Inc. product remains solely with the purchaser.