



บริษัท เอดีดี เฟอร์เนส จำกัด

ADD FURNACE CO.,LTD.

44 ซอยบรมราชชนนี 70 ถนนบรมราชชนนี แขวงศาลาธรรมสพน์ เขตทวีวัฒนา กรุงเทพฯ 10170

โทร: 02-888-3472 โทร: ออกแบบ:08-08-170-170 แฟกซ์: 02-888-3258

<https://www.add-furnace.com> E-mail: sales@add-furnace.com

GAS LEAK DETECTOR

MODEL: EW-401



EWO ENGINEERING CO., LTD.

Table of Contents

1. Specifications

1-1. Specifications of the Indicator (EW401)

1-2 . Specifications of the Detector

2. Function of Each Device and Title Explanations

2-1 . Indicator

2-2 . Detector

3. Wiring Diagram

4. Operation System Diagram

5. Installation Place and Installation Drawing

6. Operation Method and Instructions



บริษัท เอดีดี เฟอร์เนส จำกัด

ADD FURNACE CO.,LTD.

44 ซอยบรมราชชนนี 70 ถนนบรมราชชนนี แขวงศาลาธรรมสพน์ เขตทวีวัฒนา กรุงเทพฯ 10170

โทร: 02-888-3472 โทร: ออกแบบ:08-08-170-170 แฟกซ์: 02-888-3258

<https://www.add-furnace.com> E-mail: sales@add-furnace.com

1. Product Specifications

1-1. Specifications of the Indicator

Name	Gas Leak Detector (MODEL:EW40 1)
Detector Gases	LPG LN G City as (Methane, Butane, Propane) Combustible Gas
Power	AC 220V. 60 Hz (AC 230V 50 Hz AC110V / 50Hz option)
Power Consumption	Normal: 2. 5W. Alarm: 3W
Operating Temperature Range and Humidity	- 10°C~ 50°C, 0~95 % RH
Readout Range	0 ~ 100% LE L
Alarm Point	Within 25% (user adjustable* Variable setting)
Response Time	Within 20 seconds
Visual Alarm and Audio Alarm	Flickering of LED LAMP (yellow) and above 70Db of buzzer sound
Operating Indicator	Lighting of LED L AMP (green)



บริษัท เอดีดี เฟอร์เนส จำกัด

ADD FURNACE CO.,LTD.

44 ซอยบรมราชชนนี 70 ถนนบรมราชชนนี แขวงศาลาธรรมสพน์ เขตทวีวัฒนา กรุงเทพฯ 10170

โทร: 02-888-3472 โทร: ออกแบบ:08-08-170-170 แฟกซ์: 02-888-3258

<https://www.add-furnace.com> E-mail: sales@add-furnace.com

Trouble Indicator	Lighting of LED LAMP (Red)
Warm up Time	60 seconds
Connection Cable	VCT or CVVS above 0.75mm SQ Use over
Dimension	114*250*80
Outer Output	DC 12V(20~30mA Output). Contact point of non-voltage contact point NO.NC.COM(Relay contact point)
Capacity of Contact Point	A C 110/1A. DC 12~ 24 2A
Weight	Some 1,840g

1-2. Specifications of the Detector

Type	Expansion Type
Detector Gases	LPG LNG City Gas (Methane, Butane, Propane) Combustible Gas
Sensor Type	Catalytic, Combustion (Hot-wire type) Diffusion Type



Operating Temperature Rang and Humidity	-20°C~ 50°C, 0~9 5% RH
Explosion-proof Type	E xd II BT ₄
Cable Connector	Inside Dia 16mm/ Outer Dia 23mm
Dimension	1 37*142*75
Weigh t	1,036g
Readout Range	0~100%(LE L)
Response Time	Within 20 seconds

2. Function of Each Part and Title

Explanations 2-1 . Indicator (EW401)

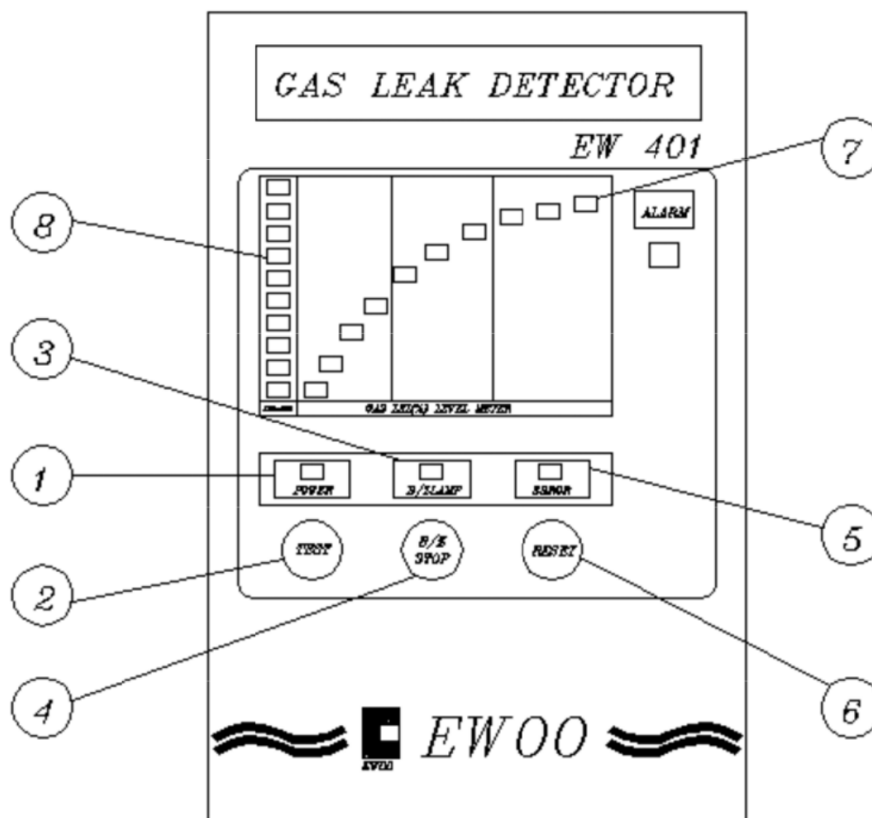



① Power L amp

- Lamp to confirm electricity status

② Circuit Test Switch

- To confirm operation status of receiver unit internal circuit (Alarm, level meter, buzzer, relay)

③ Buzzer stop Lamp

- In case of pushing the switch against

Alarm, buzzer turns off, and lamp around switch and etc. turn off.

④ Buzzer Stop Switch

- In case of pushing the buzzer stop switch against alarm, alarm

sound stops and in case numerical value of re-pushing, alarm is sounded..

⑤ Trouble Signal

- Lighted in case of abnormal detection device or its line (Green LED)

(Red LED)

⑥ Reset Switch

- As alarm is kept in case of gas leakage or line test,

it will be reversed when reversion switch is pushed

after it drops on the densitometer.

⑦ Gas Density Indicator

- Expanded gas density is marked by lamp level meter.

⑧ LEL Indication

- Table indicating lamp level meter and LEL

conversion 2-2 .Gas Density Indicator

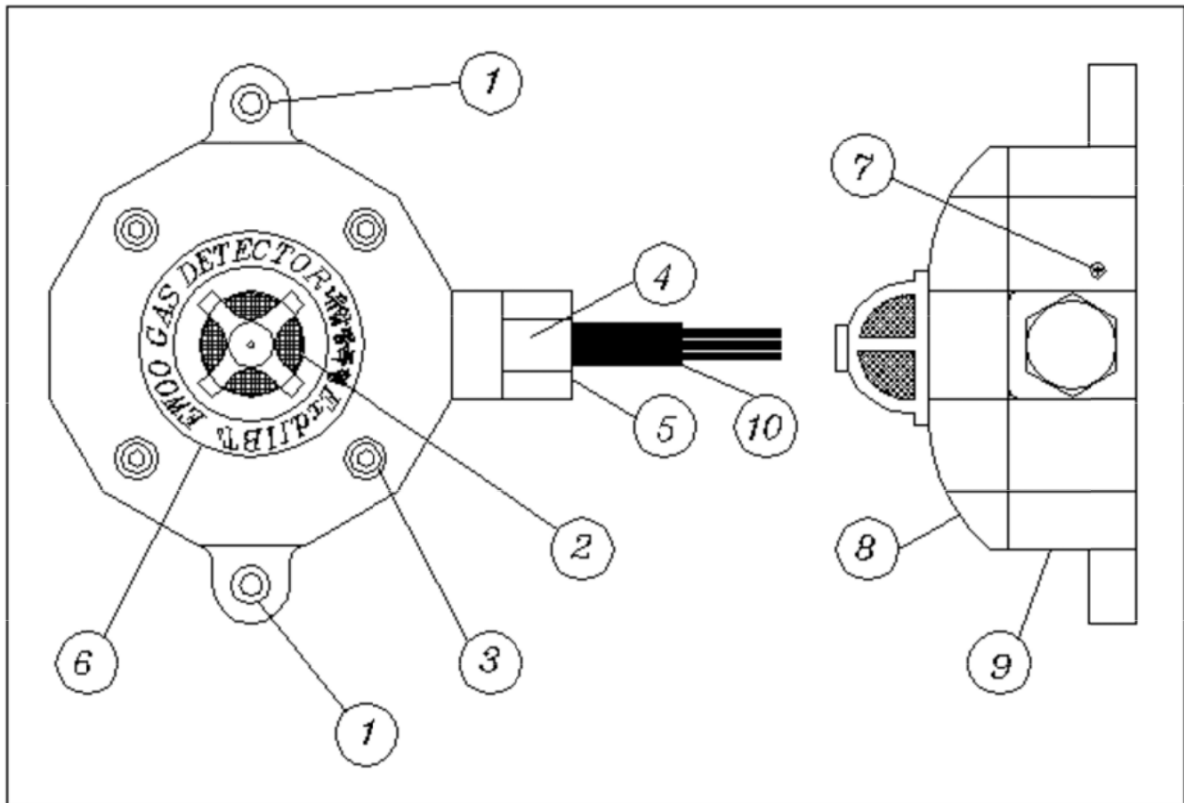

① Sensor fixing hole

- The hole for fixing the detector by bolts or nails

② Sintered Filter

- Sensor protection filter (bronze 300mesh)

③ Cover Fixing bolt

- The bolt for fixing cover and body of Detector

④ Cable grand

⑤ Cable Insert De vice

- Cable pipe or fiexible screw(Female screw)

⑥ Sticker

-4 m*6m -

M4*6mm

⑦ Ground earth

⑧ Molded Cover



⑨ Molded Body

⑩ Wire

-V CTF 0.75x3C (Blue, Brown, Green)

3. Wiring Diagram

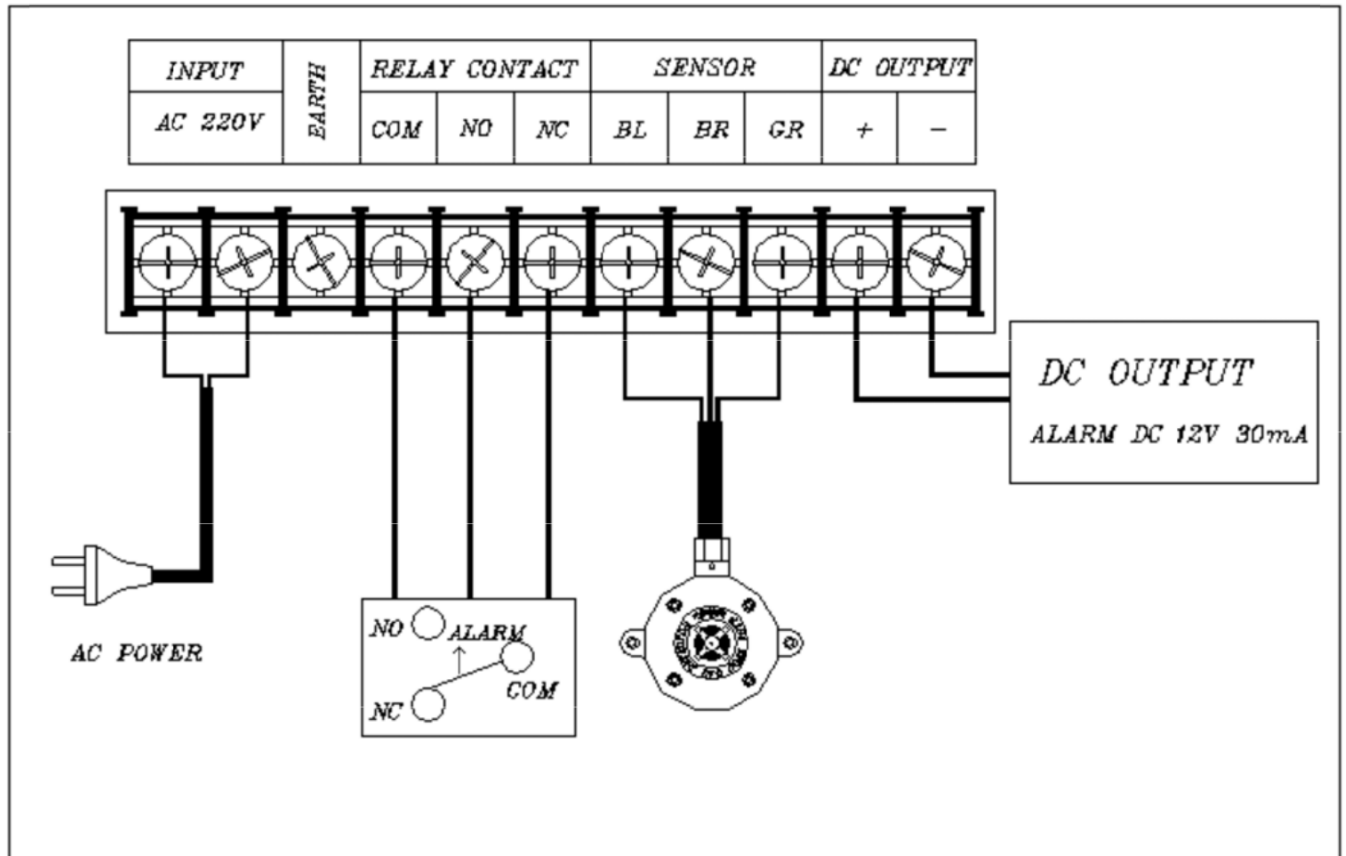

① 110/220 Input: To fix the power supply selection switch to AC110 V or 220 V and then to connect the line. (AC230V 50Hz AC110V / 50Hz option)

② Non-voltage contact point (NO.N C.COM): Contact (Switch) COM terminal and NC terminal are connected at ordinary times. In case of alarming, COM terminal and NO terminal are connected.

③ Sensor Connection Terminal (Blue, Brown, Green):It is connected to be matched with wire colors arranged in detection device. Blue (Electric Line +), Br own (Electric Line +), Green (Signal Line)

④ Signal Output (+.-): In case of al arming, it can be used for shut-off device or other various devices with DC12V 3 0mA output.



4. Operation System Diagram

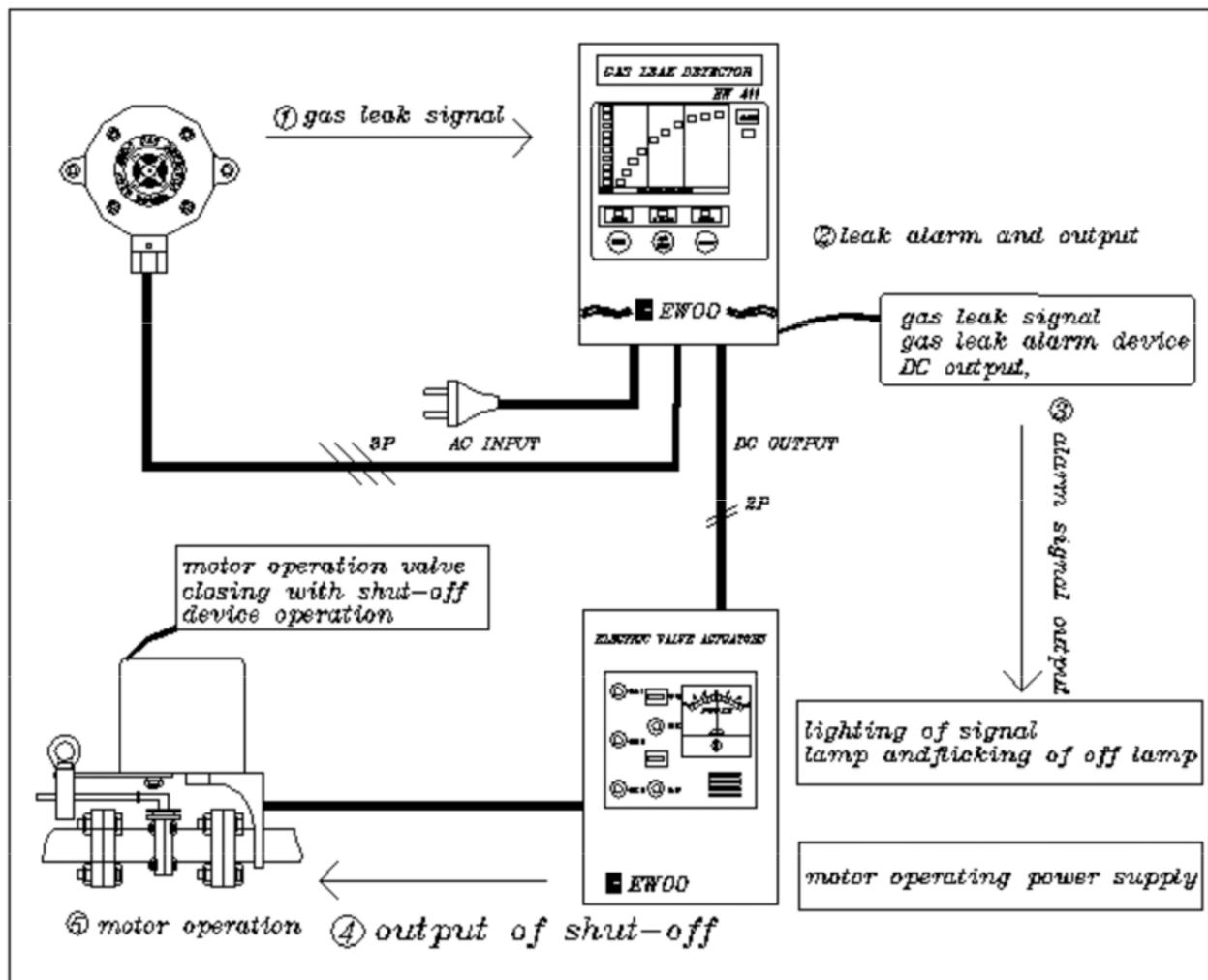

5. Installation Place and Installation drawing

5-1 . Installation Place

1. Detection device shall be installed in the place where the leaked gas easily stays, as the place where gas is easily leaked among storage facilities and gas facilities.

2. The location where detection device is installed, shall be decided as per the conditions such as characteristics of gas, instructions, structure of each device and etc.



3.A s for installation height of detection device, if the gas heavier than air, it shall be installed within 30 cm above the floor while if the one lighter than air, it shall be installed within 30 cm below the ceiling.

4.Installati on place for receiver device of gas leak alarm device shall be installed in the proper place to take every measure after alarm is sounded, as the place w here the relevant person reside s or the alarm can be identified.

5-2 . Installation Drawing

※ Installation Place: Kitchen of the restaurant, boiler room, governor room and gas storage room.

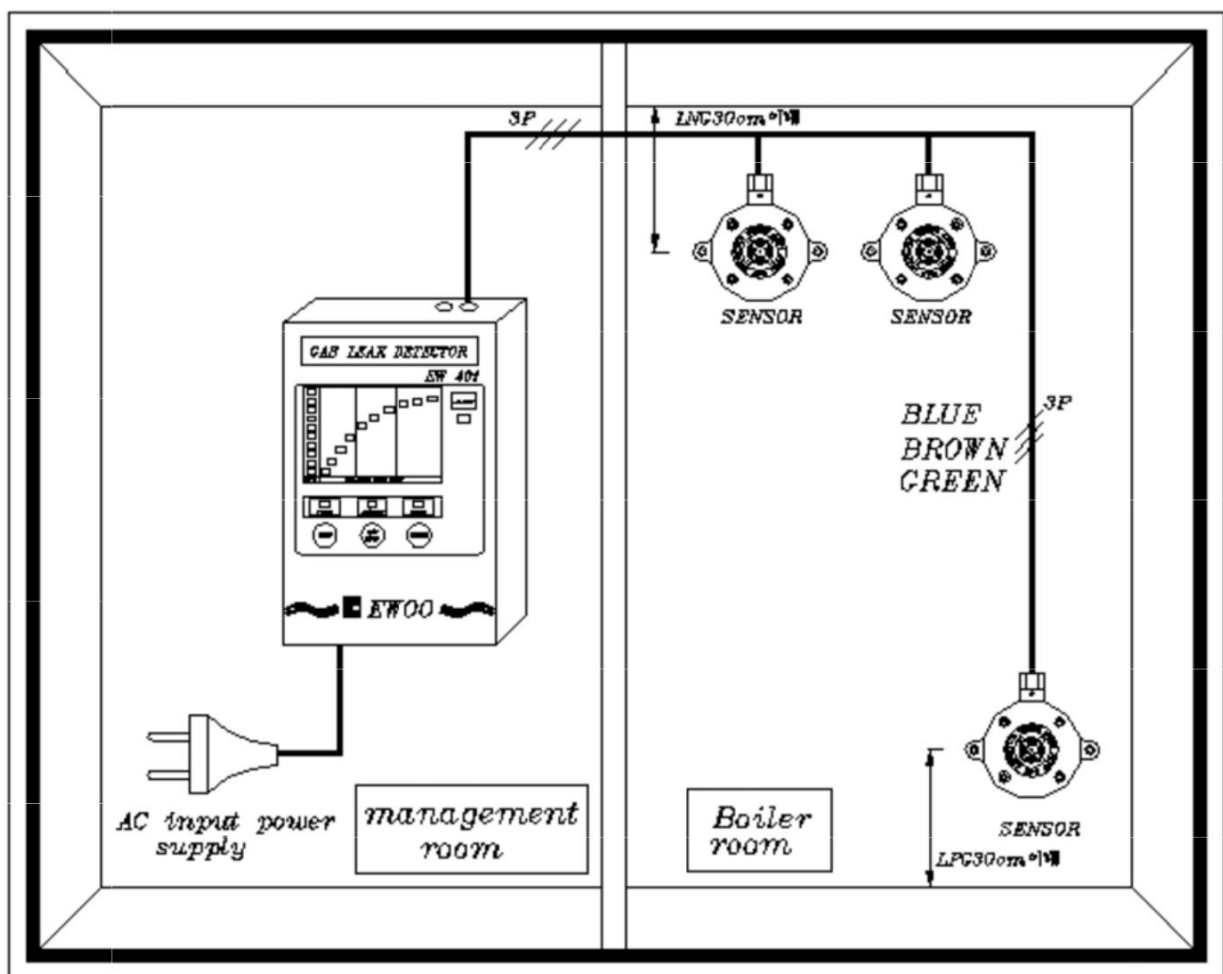



6. Operation Method and Instructions

< Operation Method >

1. To open the front case and to fix the switch to the operation voltage after finishing the connection of receiver device and detection device.
2. In case power supply switch turn on, power supply lamp will be flickered for some one minute, and in case early stabilization time is passed, power supply lamp will stop flickering and be lighted and circuit will be operated in normal way.
3. In case detection device is disconnected, buzzer is sounded and trouble signal is lighted.
4. As for test operation of gas leak alarm device, in case of pushing the circuit test button, density signal lamp is slowly up as gas is detected , and then when alarm setting device is abnormal, alarm signal lamp is lighted and alarm is sounded.
5. In case of pushing the buzzer button in order to stop the alarm sound, normal operation will be made as it becomes in normal.
6. In case disconnection signal and trouble lamp are lighted, to confirm the detection device and connection status.



บริษัท เอดีดี เฟอร์เนส จำกัด

ADD FURNACE CO.,LTD.

44 ซอยบรมราชชนนี 70 ถนนบรมราชชนนี แขวงศาลาธรรมสพน์ เขตทวีวัฒนา กรุงเทพฯ 10170

โทร: 02-888-3472 โทร: ออกแบบ:08-08-170-170 แฟกซ์: 02-888-3258

<https://www.add-furnace.com> E-mail: sales@add-furnace.com

<Instructions>

- 1. Optional disassembly, repair or alteration is not allowed by an person except the relevant personnel of our company.**
- 2. As for the product equipped with earthing terminal, earthing line shall be surely installed**
- 3. In case of connecting receiver device and detection device, the same manufacturing number shall be connected.**
- 4. To confirm the voltage before installation, to match 110V/220V conversion switch to operation voltage.**
- 5. Do not use any other gas except application objective gas.**
- 6. Do not use it in the place where there is high vapor or strong wind.**
- 7. Please check the detection element more than one time per year.**