

## HUPF Series

GAS PRESSURE REGULATOR WITH  
INCORPORATED FILTER

### INSTRUCTION SHEET



### DESCRIPTION

Spring-loaded regulator with inlet pressure compensation and zero shut-off.

The outlet pressure is kept constant with changing gas flow as a function of the spring setting. The zero shut-off prevents the outlet pressure from increasing when there is no gas flow through the regulator.

### APPLICATION

To regulate gas and air inlet pressure for gas burners, including mixed and combined systems and in industrial distribution systems.

Applicable types of fuel:

manufactured gases (town gas)

- natural gases (group H - methane)
- liquefied petroleum gas (LPG)
- non-aggressive gases
- air

The gas pressure regulators comply with the requirements of EN88, class B, group 2.

These gas pressure regulators are available in two versions; with or without incorporated filter, see product range page 2.

## SPECIFICATION

### Product range

Model HUPF (pipe sizes 1/2" up to DN 100) with filter.

### Dimensions

See dimensional drawing and table on page 4.

### Pipe size

1/2" up to 2" inlet and outlet internal pipe thread according ISO 7-1.  
DN40, DN50, DN65, DN80 and DN100 inlet and outlet flange connections according to ISO 7005 EN 1092-4

### Connections

Inlet pressure tap connections.

### Capacity

See Capacity curves HUPF Series on page 6.

### Maximum working pressure

500 mbar

NOTE: minimum inlet pressure range:

desired outlet pressure +2.5 mbar up to 1000 mbar.

### Outlet pressure range

5 to 300 mbar

The appropriate outlet pressure range is obtained by the use of different springs.

NOTE: The regulators are supplied standard with a white spring - see „Spring setting range“ below

### Closing pressure

Conform EN 88 specification (i.e. zero shut-off)

### Torsion and bending stress

Pipe connections meet group 2, according to EN 88 requirements.

### Set point accuracy

According to EN88, class A group 2.

### Max. allowed pressure

Up to 1 bar without body damages

### Ambient temperature range

-15 °C....+60 °C

### Material of pressure receiving parts

Elastomer EN549

### Sealing elements

Hydrocarbon resistant NBR rubber type NBR 70

### Safety diaphragm

An external breather/outlet pipe is not necessary as the incorporated safety diaphragm ensures that, in the event of

breakage of the operating diaphragm. No gas leakage into the environment of over 30dm<sup>3</sup>/h is possible. The above in compliance with para. 3.3.2. of UNI EN 88 specification.

### Body material

Aluminium alloy die cast EN AB 46100, EN AB43100

### Internal parts

AISI 304/Delrin

### Filter

HUPF Series only.

Filter element Synthetic fiber DVGW G260/1

### Filtering grade

= 50µ

### Standard and Approvals

The HUPF and HUP Series gas pressure regulator with and without incorporated filter conform to the following EC-directives:

• Gas Appliance Directive (90/396/EEC)

HUP .....B

PIN: 0063AR4719

HUPF .....B

PIN: 0063AR4719

### Adjustment spring range

Model	HUPF015B110 HUPF020B110 HUPF025B110	HUPF032B110 HUPF040B110	HUPF050B110	Available till end series		from 2008
				HUPF065B110 HUPF080B110	HUPF100B110	HUPF065B110 HUPF080B110 HUPF100B110
Range(mbar) and colour	Spring code					
5 - 13 Green	HRSP150M1	HRSP153M1	HRSP155M1	HRSP156M1	HRSP158M1	HRSP258M1
7 - 20 Red	HRSP150M2	HRSP153M2	HRSP155M2	HRSP156M2	HRSP158M2	HRSP258M2
10 - 30 White	HRSP150M3	HRSP153M3	HRSP155M3	HRSP156M3	HRSP158M3	HRSP258M3
25 - 70 Yellow	HRSP150M4	HRSP153M4	HRSP155M4			HRSP258M4
65 - 150 Violet	HRSP150M7	HRSP153M7	HRSP155M7			HRSP258M7
140 - 300 Orange	HRSP150M8	HRSP153M8	HRSP155M8	HRSP156M8	HRSP158M8	HRSP258M8
			Old range	Available till end series		
			25 - 55 Yellow	HRSP156M4	HRSP158M4	
			110 - 150 Violet	HRSP156M7	HRSP158M7	

## INSTALLATION

### Important

1. **Read these instructions carefully. Failure to follow the instructions could damage the product or cause a hazardous condition.**
2. **The installation has to be carried out by qualified personnel only.**
3. **Carry out a thorough checkout when installation is completed.**



### Warning

- Turn off gas supply before installation.
- Do not remove the seal over regulator inlet and outlet, until ready to connect piping.
- Do not remove the perforated diaphragm breather cap (3) and do not obstruct the hole.
- The regulator must be installed so that the arrow on the regulator points in the direction of the gas flow.

### Mounting position

To ensure perfect regulator operation, regulator should be assembled horizontally. They can however be installed in different positions up to an angle of 90°.

### Mounting location

Contact between the regulator and walls or a floor is not permitted. Maintain a distance of at least 50 mm.

Note: In case of the HUPF Series, the distance between the bottom and the ground must be at least 400 mm, to facilitate filter cleaning and inspection.

### Main gas connection threaded regulators

- Take care that dirt cannot enter the gas regulator during handling.

- Ensure the gas flow in the same direction as the arrow on the housing of the gas regulator.
- Use a sound taper fitting with thread according to ISO 7-1 (BS21, DIN 2999) or a piece of new, properly reamed pipe, free from swarf.
- Do not thread or tighten the pipe or pipe fitting too far. Otherwise regulator distortion and malfunction could result.
- Apply a moderate amount of good quality thread compound to the pipe or fitting only, leaving the two end threads bare. PTFE tape may be used as an alternative.
- In order to tighten the pipe in the regulator, do not use the sleeve of the upper cover as a lever but use a suitable wrench operating on the wrench bosses.

### Main regulator connection flanged regulators

- Take care that dirt cannot enter the gas regulator during handling.
- Ensure the gas flow in the same direction as the arrow on the housing of the gas regulator.
- Ensure that inlet and outlet flanges are in line and separated from each other enough to allow the regulator to be mounted between them without damaging the gasket.
- Place gasket. if necessary grease it slightly to keep it in place.
- Mount gas regulator between flanges using the bolts for each flange.



### Warning

#### Tightness test after installation

- Spray all pipe connections and gaskets with a good quality gas leak detection spray.
- Start the appliance and check for bubbles. If a leak is found in a pipe connection, remake the joint. A gasket leak can usually be stopped by tightening the mounting screws. Otherwise replace the gas pressure regulator.

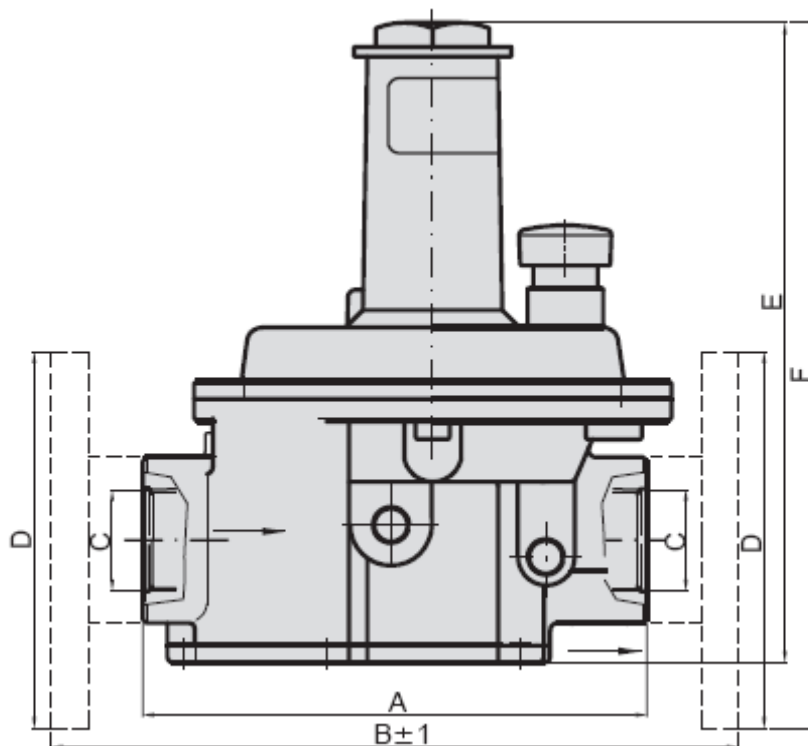

Governors with built in filter

Model	Connection (inch)	Max. operating pressure (mbar)	Overall dimensions (mm)					
			A	B	C	D	E	F
HUPF015B110	1/2"	500	138		1/2"		175	
HUPF020B110	3/4"	500	134		3/4"		175	
HUPF025B110	1"	500	134		1"		175	
HUPF032B110	1"1/4	500	194		1"1/4		255	
HUPF040B110	1"1/2	500	194		1"1/2		255	
HUPF050B110	2"	500	236		2"		316	
HUPF050B310	DN50/S	500		352		DN50		349
HUPF065B350	DN65	500		350		DN65		427
HUPF080B350	DN80	500		350		DN80		434
HUPF100B350	DN100	500		415		DN100		502

## ADJUSTMENTS



### Caution

- Adjustments must be made by qualified personnel only!

#### Outlet pressure adjustment

(Tolerance: better than 15% of outlet pressure setting)

1. Remove the upper cap (1).
2. To obtain the required outlet pressure value, turn the set screw (4). Turn this set screw clockwise to increase the outlet pressure, counter-clockwise to decrease it.
3. Clearly mark the adjusted value of the outlet pressure.
4. Replace the upper-cap (1) and seal it with lead if necessary.

#### Replacing spring

1. Remove the upper-cap (1) of the pressure regulator.
2. On fully unscrew the ring nut (4)
3. Remove old and replace new spring.
4. Screw the ring-nut (4) back in.
5. Adjust the required outlet pressure by proceeding with step 1 to 4 of „Outlet pressure adjustment“ section on this page.

#### Final checkout of the installation

Set the appliance in operation after any adjustment and observe several complete cycles to ensure that all burner components function correctly.

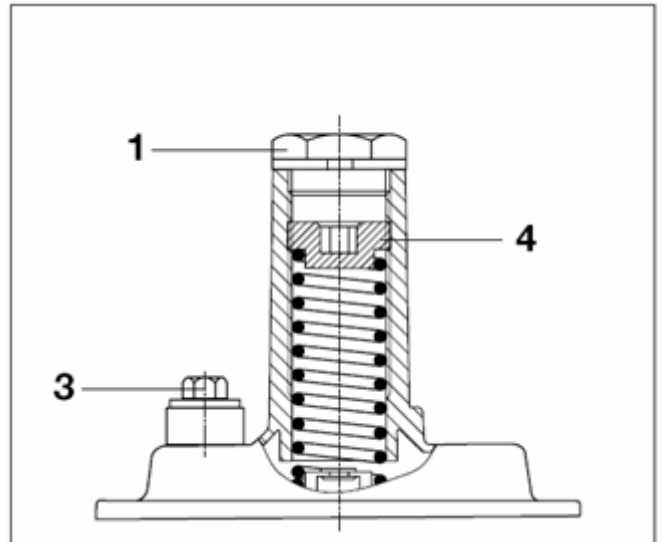

## MAINTENANCE

The regulators are completely maintenance-free. In the event of a breakdown, a general overhaul and factory testing is recommended.

#### Filter maintenance (HUPF)

1. Remove the screws at the bottom of the gas regulator and remove the cover.
2. Remove the filter cartridge and clean the filter housing thoroughly.
3. Replace the old filter element with the new one.
4. Reassemble the cover, ensuring that the guides inside the cover is aligned with the filter cartridge.
5. Tighten the screws, and check for gas leak by performing a tightness test.

## MAINTENANCE

#### Replacement filter cartridges

Filter cartridge	Used with model
KTFL31150/C1	HUPF015B110 HUPF020B110 HUPF025B110
KTFL31153/C1	HUPF032B110 HUPF040B110
KTFL31155/C1	HUPF050B110
KTFL31156/C1	HUPF065B110 HUPF080B110
KTFL31158/C1	HUPF100B110

**Capacity curves of HUPF series with regulator in stable position**  
 (m<sup>3</sup>/h natural gas at 1013mbar, 15C°)

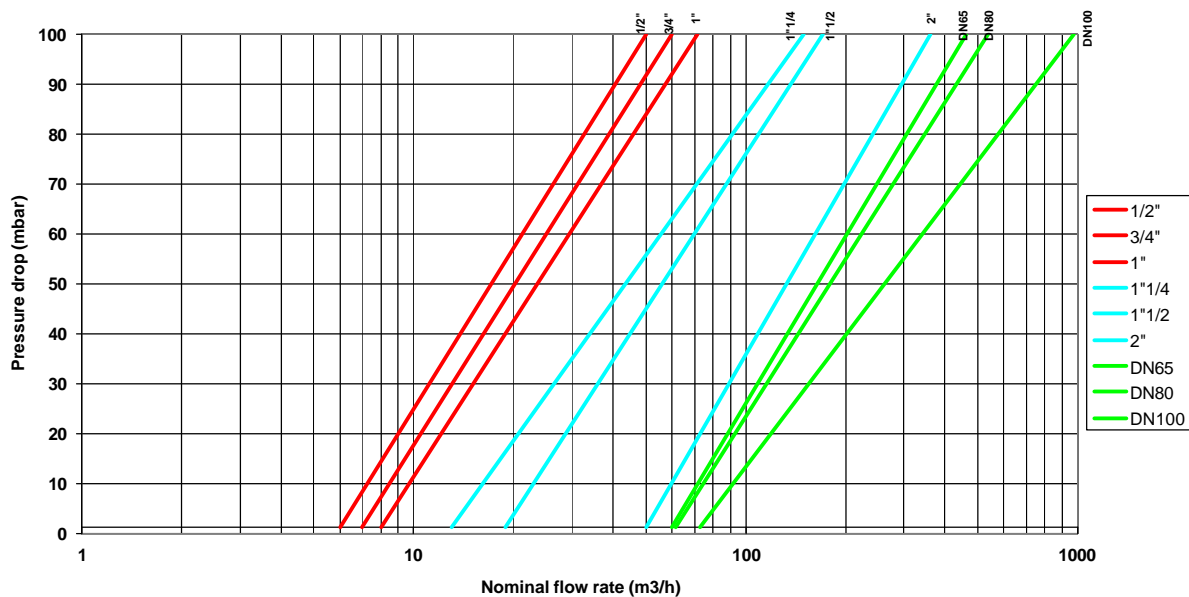

**Honeywell**

Manufactured for and on behalf of the Environmental and Combustion Controls Division of Honeywell Sàrl, Ecublens, Route du Bois 37, Switzerland by its Authorized Representative:

Automation and Control Solutions  
 Combustion Controls Europe  
 Honeywell BV  
 Phileas Foggstraat 7  
 7821 AJ Emmen  
 The Netherlands  
 Tel.: +31 (-)591 695911  
 Fax: +31 (-) 591 695200  
<http://europe.hbc.honeywell.com>