



บริษัท เอดีดี เฟอร์เนส จำกัด

ADD FURNACE CO.,LTD.

44 ซอยบรมราชชนนี 70 ถนนบรมราชชนนี แขวงศาลาธรรมสพน์ เขตทวีวัฒนา กรุงเทพฯ 10170

โทร: 02-888-3472 โทร: ออกแบบ:08-08-170-170 แฟกซ์: 02-888-3258

<https://www.add-furnace.com> E-mail: sales@add-furnace.com

Honeywell

A4021 Series

VALVE PROVING SYSTEM

PRODUCT HANDBOOK



APPLICATION

The A4021 is a self-checking microprocessor based Valve Proving System (VPS). The A4021 checks the effective closure of automatic shut-off valves by measuring the pressure differential between two valves during the test sequence. Subbase and pressure switch are required to complete the system.

When during the test sequence of the A4021 a failing valve is detected, the A4021 will go into a non-volatile lock-out status, generates an alarm and prevents a burner start-up.

The intended application is for gas fired power burners and other large capacity gas firing installations, where according to the European norm EN676 a valve proving system can be used as an alternative for pre-purging the combustion chamber. And for all combustion applications with or without pre-purge with a capacity of more than 1200 kW a valve proofing system is mandatory.



CONTENTS

Application	1
General	2
Application (continued)	2
Features	3
Description	4
Working principle	4
Specifications	7
Mechanical	7
Electrical	7
Functional	7
Dimensional drawings	9
Safety Provisions	10
Energizing valve 1 and 2	10
Use of terminal 12	10
Fail--safe relay drivers	10
Anti--recycle--counter	10
Calculations	11
General.....	11
Calculation examples	11
Installation and wiring	12
Installation	12
Mounting Wiring Subbase	12
Wiring	12
General considerations	12
Wiring	12
Pressure switch	12
General wiring diagrams	13
Applications with EC/RM7850	14
Checkout	17
Final checkout of the installation	17
Troubleshooting	18
Standards and Approvals	19
Ordering information	20



GENERAL

Application (continued)

The A4021A can be used for both single and combination valves with or without pilot valve.

For valves with large nominal sizes, valve proving is possible by use of auxiliary valves (pre-configuration only, see page 4).

For mounting the A4021 on a typical combination valve as the VQ400 Series or on a large valve like the VE5000 Series

there is a mounting bracket available (order separately) According the European standard EN676 a valve proving system can be used under certain conditions, as an alternative for pre-purging the combustion chamber. EN676 and EN746-2 prescribe a valve proving system for capacity rating over 1,200 kW, see Table 1.

Table 1. Application valve proving systems according EN676

Heat-Input [kW]	With Pre-Purge			Without Pre-Purge		
	Main Gas	Start Gas		Main Gas	Start Gas	
		≤ 10%	≥ 10%		≤ 10%	≥ 10%
≤ 70	2x B	B*)	2x B	2x A or 2 x B +VPS	A**)	2xA
> 70, ≤ 1200	2x A	2xA	2x A	2x A + VPS	2x A	2xA
> 1200	2 x A + VPS	2xA	2x A	2x A + VPS	2x A	2xA

- NOTE: A: Automatic shut-off valve approved on EN161, class A
 B: Automatic shut-off valve approved on EN161, class B
 □ Valve Proving System required
 ■ Valve Proving System as alternative for pre-purge of the combustion chamber
 *) For third family gases: two class B valves are required
 **) For third family gases: two class A valves are required

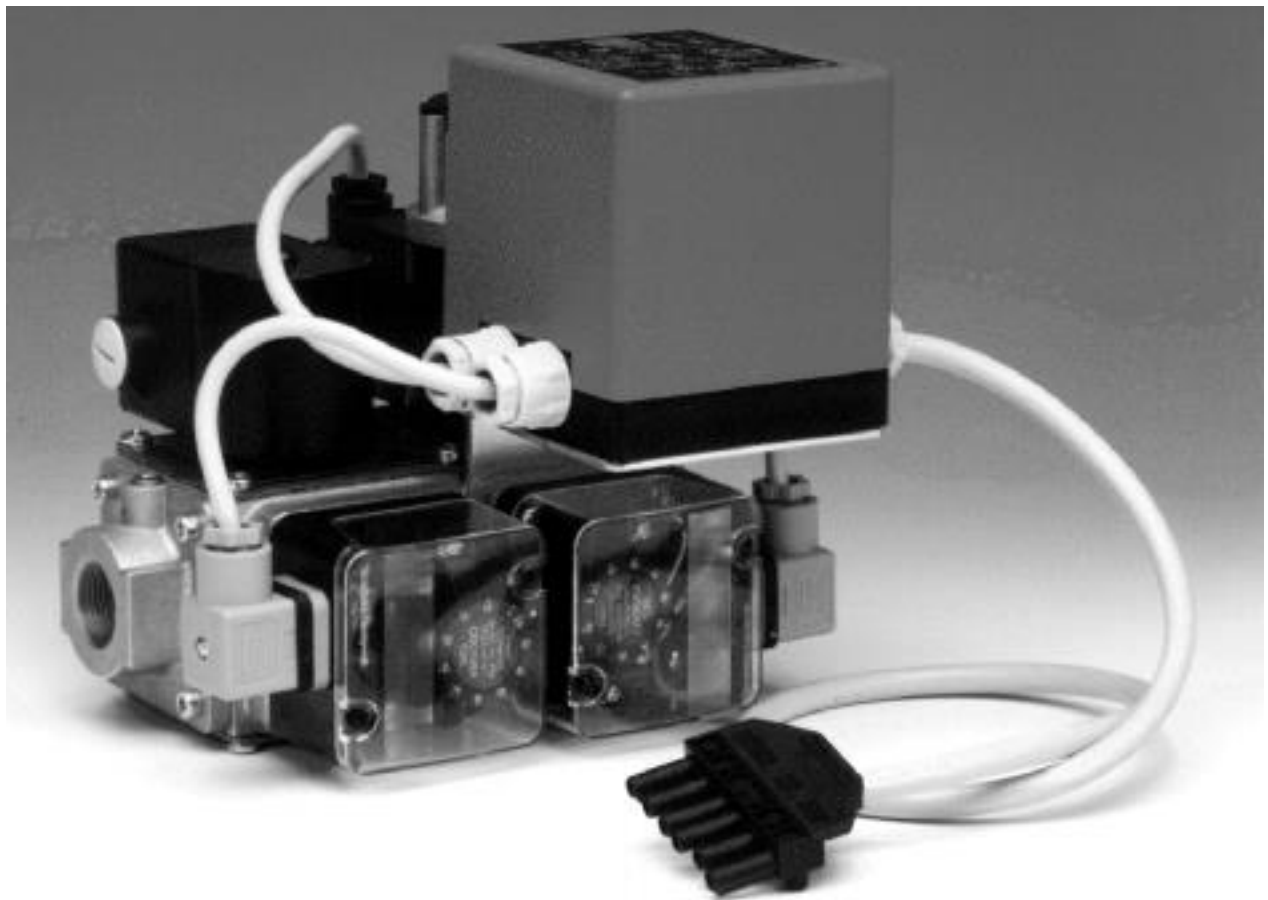

Fig. 1. VQ400 combination valve with A4021 valve proving System.



บริษัท เอดีดี เฟอร์เนส จำกัด

ADD FURNACE CO.,LTD.

44 ซอยบรมราชชนนี 70 ถนนบรมราชชนนี แขวงศาลาธรรมสพน์ เขตทวีวัฒนา กรุงเทพฯ 10170

โทร: 02-888-3472 โทร: ออกแบบ:08-08-170-170 แฟกซ์: 02-888-3258

<https://www.add-furnace.com> E-mail: sales@add-furnace.com

FEATURES

- Microprocessor technology
- Based on 7800 SERIES Burner Programmer safety technology.
 - Dynamic relay test
 - Safe start test
 - Self--diagnostic test
- Testing independent of type of gas at any inlet pressure.
- Valve proving done by using the line pressure of the gas.
- Non--volatile lockout.
- Automatic valve proving before heat demand, after heat--demand or during pre--purge possible.
- Different test--times (per valve) available by different O.S. numbers.
- Clear visual indication of the test sequence and faults--causes through 5 LEDs.
- Storage of fault code when line interruption occurs
- Can be applied in all common valve configurations
- 2--wire gas pressure switch.
- Output for external alarm signal.
- Optional external remote reset.



DESCRIPTION

The A4021 valve proving system checks the effective closure of the valves *before* burner start-up (pre-configuration) or *at the end* of a heat demand (post-configuration). The configuration can be set by means of wiring the A4021 in two different ways, see Fig. 2. and 3.

The flow chart (Fig. 5.) and sequence diagram (Fig. 6.) explain the procedure during the valve proving.

An external pressure switch monitors the pressure between both valves. The pressure switch must be set to half the inlet pressure in order to test both valves with the same sensitivity. After a short interruption of the mains supply during valve proving or during RUN, the A4021 restarts automatically. The A4021 valve proving system can be used with several pilot-valve configurations, like intermittent and interrupted pilot systems and 3-valve configurations as well.

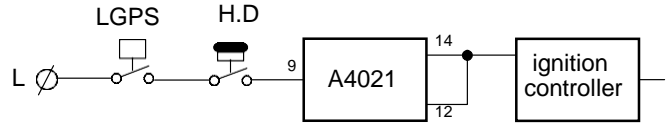

Fig. 2. Valve proving *pre-configuration*.

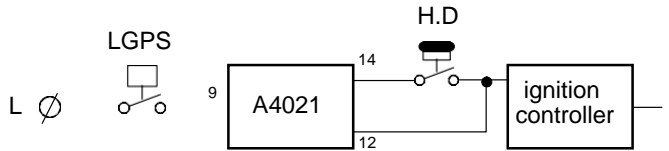

Fig. 3. Valve proving *post-configuration*.

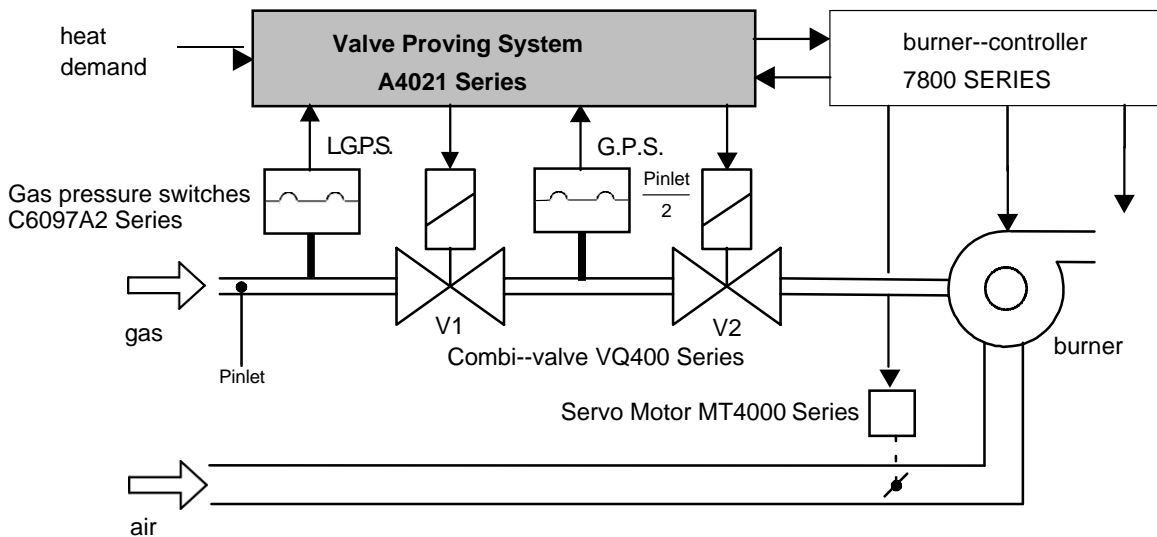

Fig. 4. System set-up .

Working principle

The A4021 valve proving system is based on the pressure status-principle. This means that the valves are checked by means of measuring (on/off) the pressure in the gas-pipe between the two safety-valves. This system will only work when there is sufficient gas-pressure (line-pressure). Therefore a Low Gas Pressure Switch (LGPS) is part of the installation. When the line-pressure (Pinlet) is too low the LGPS will disable the valve proving system.

The section between the two valves is filled with gas (high-pressure status) by opening valve-1 (upstream valve) and the pipe is emptied (low-pressure status) by closing valve-1 and opening valve-2 (down-stream). When one of the valves is leaking this will mean that either the pressure will not maintain the high-pressure status or the low-pressure status at the end of the test period.

For this method of testing, the test time is a function of three parameters.

- inlet pressure
- volume between the valves.
- maximum burner capacity.

The test time can be calculated as given on page11.

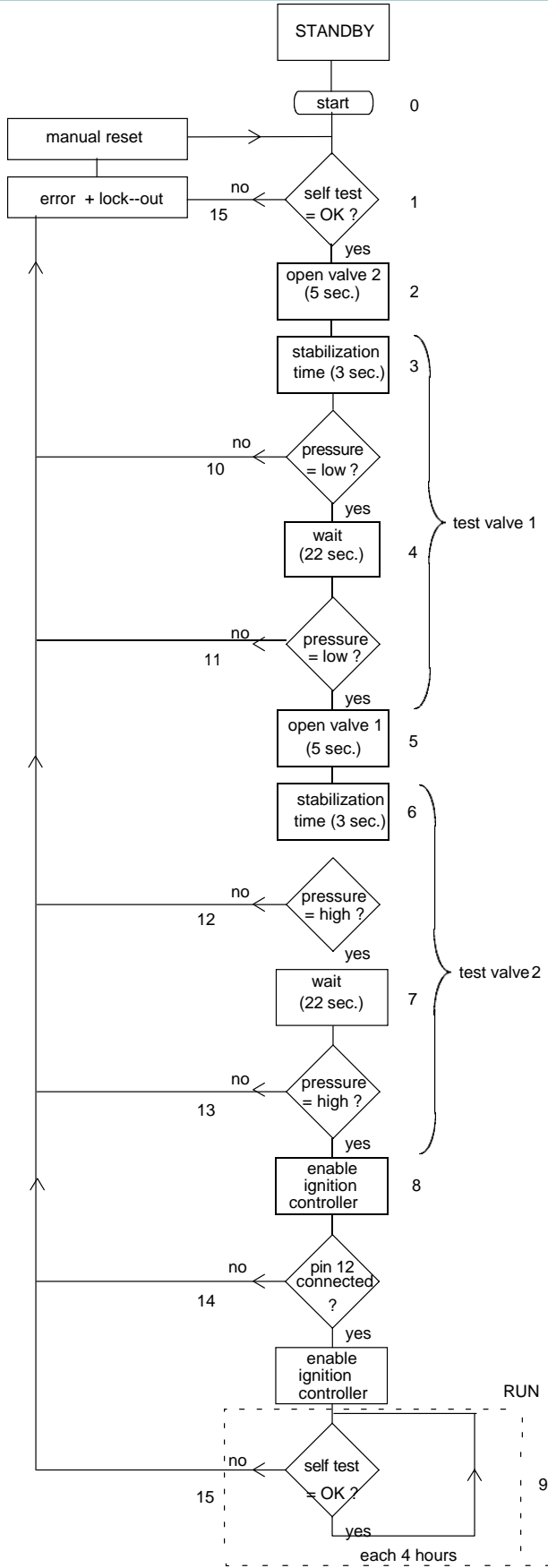

Table 2. Sequence timings for normal operation

State	Description	Time ¹⁾ (s)
0	STANDBY	infinite ²⁾
1	self- test + memory test	< 2
2	V2 powered	5
3	waiting for pressure to get low	3
4	wait	22
5	valve 1 powered	5
6	waiting for pressure to get high	3
7	wait	22
8	waiting for ignition controller to start	indefinite ³⁾
9	RUN period, every 4 hours self--test	
10	alarm, "error during test valve 1"	indefinite
11	alarm, "valve 1 failing/leaking" ⁵⁾	indefinite
12	alarm, "error during test valve 2"	indefinite
13	alarm, "valve 2 failing/leaking" ⁵⁾	indefinite
14	alarm, "error heat demand"	indefinite
15	alarm, "self--test error" ⁴⁾	indefinite

- 1) Timings depending on O.S. numbers, shown A4021A1002/1010
- 2) STANDBY can be infinite time period
- 3) Depending on pre--purge and start--up time of the used ignition controller
- 4) When during the test sequence a fault is discovered by the A4021, the system will go into a non- volatile lock--out and generate an alarm "self test error" (see also Troubleshooting section).The "self test error" also occurs when the anti--recycle--counter reaches the value 10, see also page 10 of the Product handbook.
- 5) Leakage ≥ 0.1 % of maximum flow rate.

! WARNING

No standard valve proving after lock--out of the ignition controller. Valve proving after lockout maybe required, this can be achieved by special wiring diagrams. E.g. when a DTSP switch is used to reset the ignition controller and interrupting the heat--demand for the A4021A.

Fig. 5. General flow chart valve proving (given timings for A4021A1002/1010)

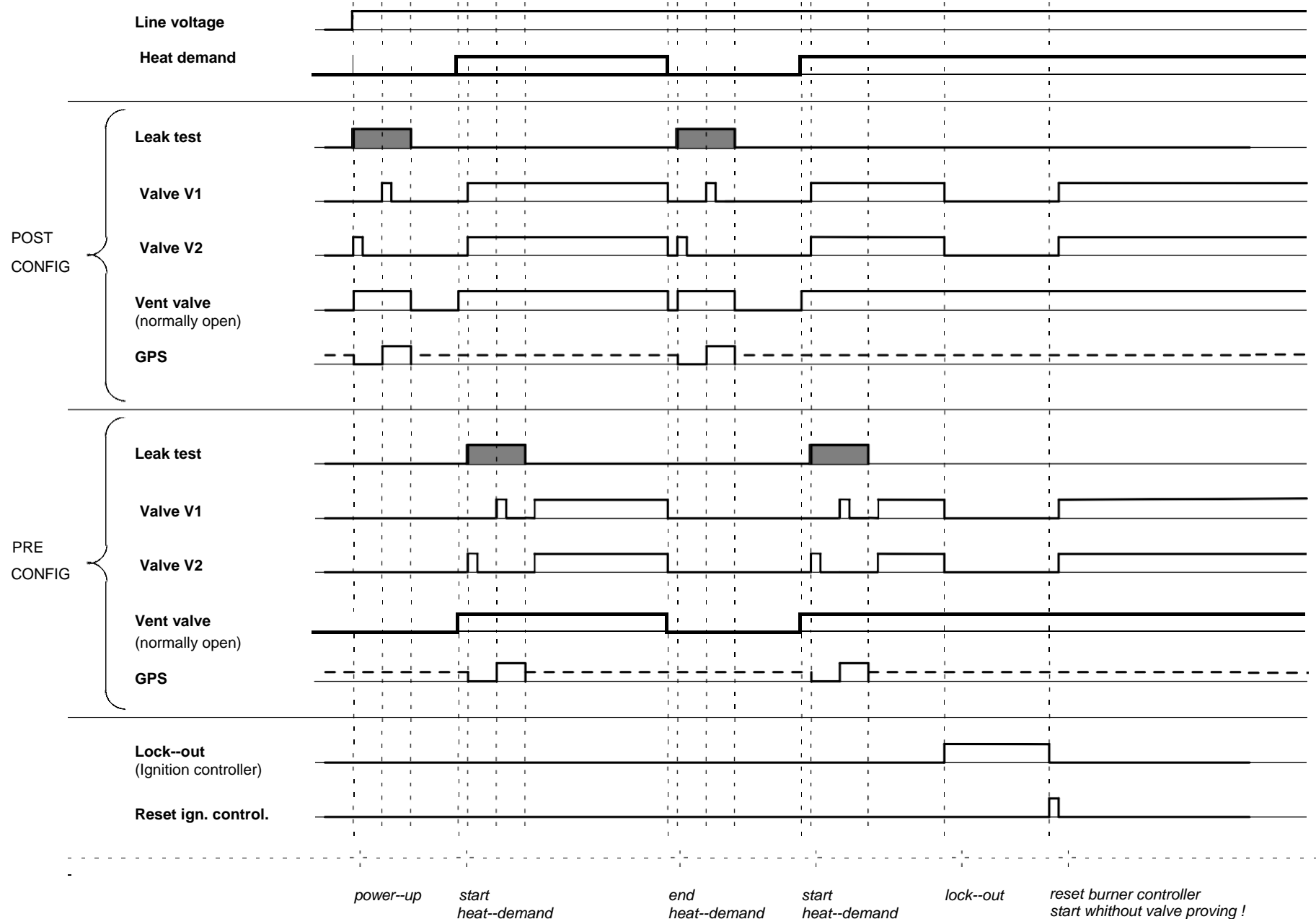

Fig. 6. System sequence of A4021A in post and pre-configuration.



SPECIFICATIONS

Mechanical

Model

A4021A

Dimensions

Refer to Fig. 7.

For mounting bracket dimensions refer to Fig. 8.

Weight

Including subbase: 0.65 Kg

Mounting

ZL030001 subbase.

The subbase can be assembled by 2 screws on a panel. The cover can be removed by loosening one screw. For mounting hole dimensions see Fig. 7. installation drawing.

Orientation

There are no restrictions in the orientation.

Environmental ratings

Ambient temperature range:

Operating :--10 ... 60 °C

Storage :--40 ... 80 °C

Humidity: :0 – 95% RH at 40 °C (non--condensing)

Vibration :0.5 G environment

Electrical

Supply voltage

Line voltage: 220 ... 240 Vac, 50 Hz

100 ... 120 Vac, 50 Hz

Refer to Table 3.

Other voltage ranges and frequencies are available on request.

Fusing

The A4021A should be externally fused to prevent damage to the valve proving system, wiring or peripherals

External fuse: 16 A slow max.

Internal fuse: 5 A slow max.

Power consumption

Maximum 4.5 VA

Electrical ratings

Valve outputs: 4A, cos. φ 0.7

Vent valve output: 1A, cos. φ 0.7

Ignition controller output: 4A, cos. φ 0.7

Alarm output: 2A, cos. φ 0.7

Electrical connection

4 Wiring conduit according to PG11 are provided in the subbase. M3.5 screw terminals, including earth connection.

Enclosure

IP40

Functional

Field adjustments(calibration)

None

Test--times

Depending on O.S. number.

For A4021A1002 and A4021A1010 per valve: 25 s.

Total test--time(depending on test time per valve)

For model A4021002 and A4021A1010: approx. 65 seconds

Reset

NON--volatile lock--out

Manual, with push--button on controller or with remote reset button.

Design life

> 10 years or 250.000 cycles.

Recommended pressure switch

C6097A2 gas pressure switch



Table 3. Connections for A4021A pre-- and post configuration with contact ratings

Terminal No.	Abbreviations		Direction	Description	Ratings (220 ... 240Vac/100 ... 120Vac, depending on O.S. number)
	pre	post			
1	NO	NO	input	Normally Open contact of the pressure switch (high pressure)	n.a.
2	RESET	RESET	input	Input for external reset connect with momentary switch to line	n.a.
3	LINE	LINE	power--input	Line voltage input for valve proving system.	n.a.
4	N	N	power--input	Neutral input for valve proving system.	n.a.
5	N	N	power	Neutral for external devices.	n.a.
6	N	N	power	Neutral for external devices.	n.a.
7	V1--IN	V1--IN	input	Valve--2 voltage from ignition controller	n.a.
8	V2--OUT	V2--OUT	output	Output connect with Valve--2	4A
9	HD	LGPS	input	Heat--demand input (pre--configuration) or LGPS input (post--configuration)	n.a.
10	ALARM	ALARM	input	Alarm input	n.a.
11	ALARM	ALARM	output	Alarm output	2A
12	RB	RB	input	Read back signal for: heat--demand (post-- config.) ign. contr. (pre--config.)	n.a.
13	VENT	VENT	output	Normally open valve output	1A
14	IGNCTR	HD	output	Heat call signal to ignition controller, when there is a heat call and the valve proving has taken place	4A
15	V2--IN	V2--IN	input	Valve--1 voltage from ignition controller	n.a.
16	V1--OUT	V1--OUT	output	Output connect with Valve--1	4A

NOTE: $\cos. \phi = 0.7$ for all outputs



DIMENSIONAL DRAWINGS

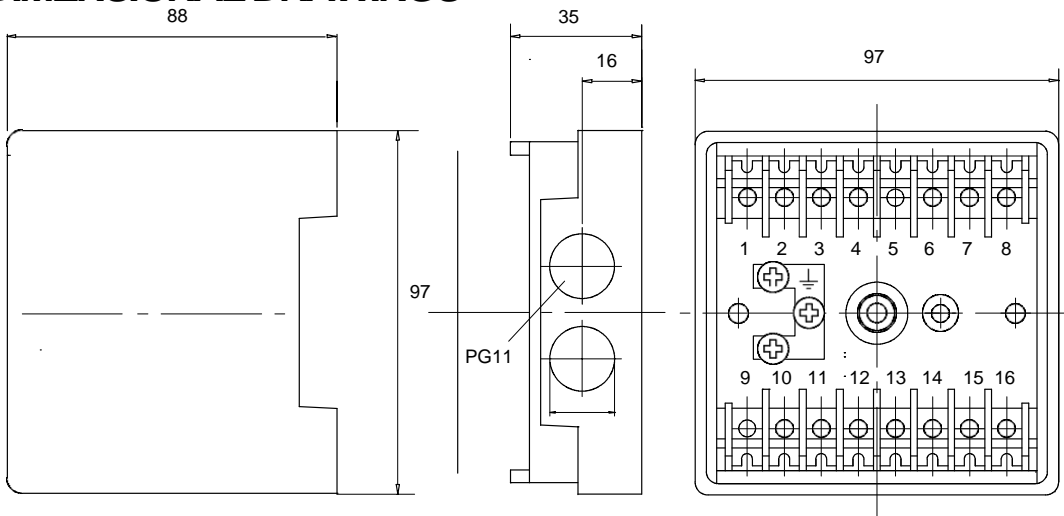

Fig. 7. Mounting dimensions of A4021A and subbase in millimeters

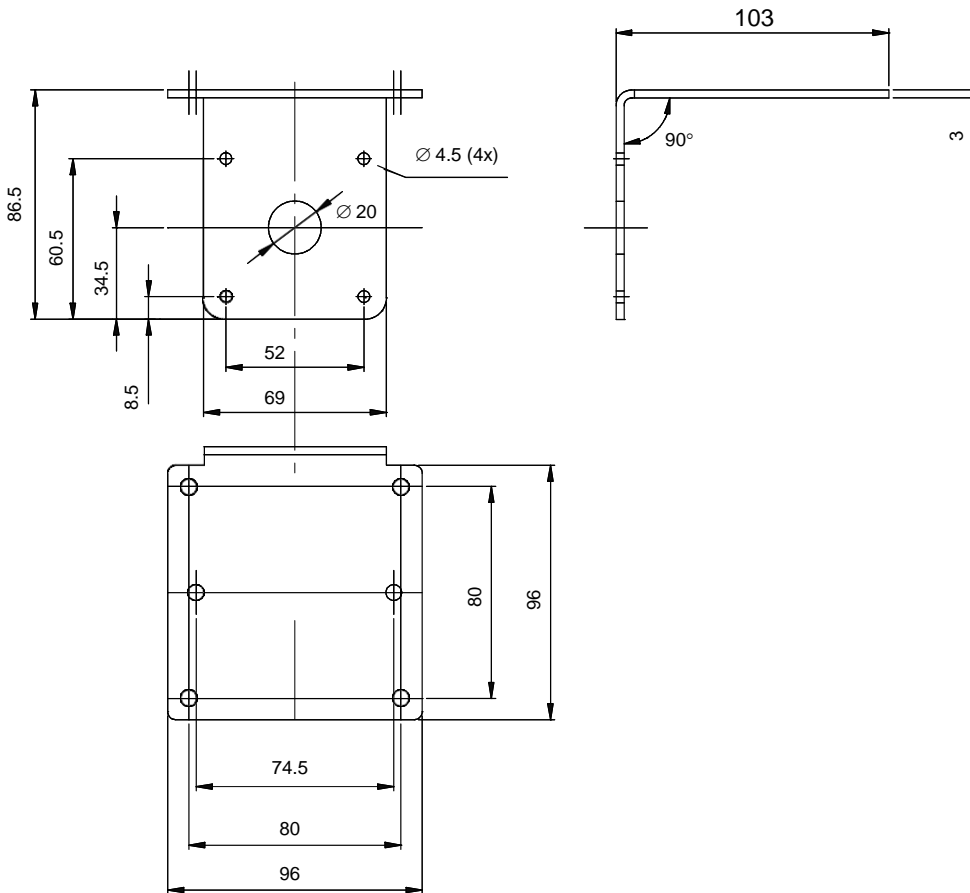

Fig. 8. Mounting bracket A4021A for VQ400 and VE5000 Series in millimeters.



SAFETY PROVISIONS

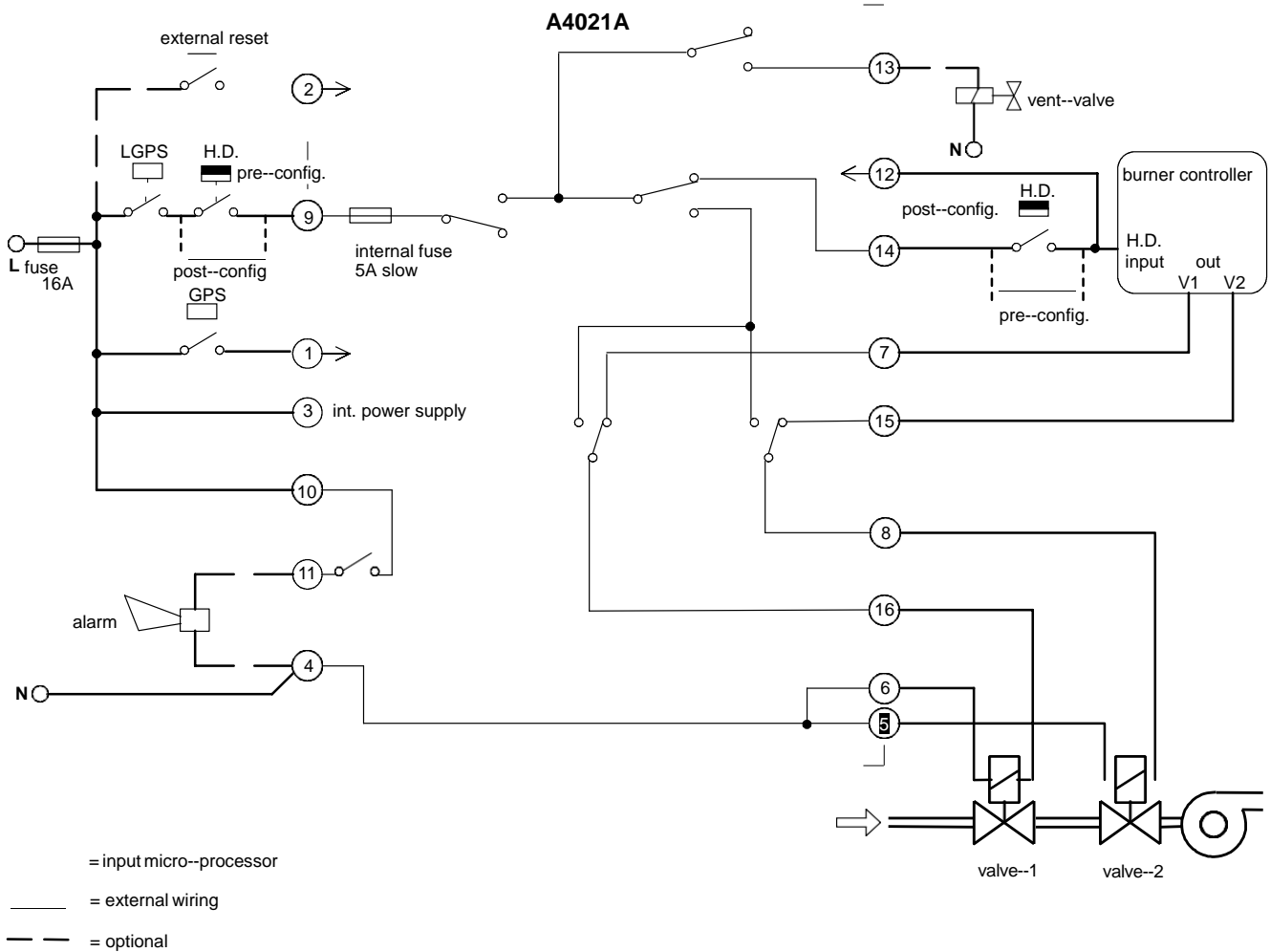

Fig. 9. Simplified internal schematic and wiring diagram pre- and post-test configuration.

Energizing valve 1 and 2

The hardware of the A4021A prevents that during the valve proving both valves can be opened at the same time.

Use of terminal 12

With terminal 12 of the valve proving system the heat demand status is checked by the valve proving system in post configuration. For the pre-configuration it is necessary that terminal 12 and 14 are connected.

If terminal 12 is not connected, the A4021A will raise an alarm (error heat demand).

Fail-safe relay drivers

The fail-safe relay drivers which are used to give the heat-demand to the burner controller are fail safe.

Anti-recycle-counter

For reason that during each valve proving a small amount of gas enters the combustion chamber, extra safety provisions are build in to prevent the A4021A from continuously recycling, in case of failures of the complete burner control system. This safety feature is provided by an anti-recycling counter in the A4021A. When the heat-demand signal disappears during a valve proving or within 10 seconds, after the valve-proving is finished. This leads to lockout (error self-test) of the A4021A when this behavior occurs 10 times in a row. The counter will be reset by the first heat-demand which lasts longer than the A4021A total-test time + 10 seconds. In this way the A4021A offers additional safety.



CALCULATIONS

General

The maximum allowable leak-rate (according the EN676 and EN746--2) is 0,1 % of the maximum burner capacity. The test time necessary to detect a falling valve is a function of:

- inlet pressure
- test volume
- burner capacity.

When the volume between two safety--valves is bigger it takes more time (in case of a leaking valve) to change the

status of the gas pressure switch. The correct OS--number for the A4021A can be selected after calculating the appropriate test--times for the intended application.

The switching point of the pressure--switch is set to 50 % of the maximum inlet pressure.

The test period T_p is calculated from the inlet pressure P_i , the test volume V_p (see Table 4.) and maximum burner capacity Q_m , in formula:

$$T_p \equiv \frac{2 \times P_i \times V_p}{Q_m} \text{ [s]}$$

P_i = inlet pressure [mbar]

V_p = test volume [dm³], see also Table 4.

Q_m = burner capacity [dm³/h]

Table 4. Volumes in dm³ for UGV valves V_p with length of pipe L (including V1 and V2)

DN	Length between valves (m)					per extra meter
	0	0,5	1	1,5	2	
10T	0.06	0.10	0.14	0.18	0.22	0.08
15T	0.06	0.15	0.24	0.33	0.42	0.18
20T	0.12	0.28	0.43	0.59	0.74	0.31
25T	0.19	0.44	0.68	0.93	1.2	0.49
32T	0.69	1.1	1.5	1.9	2.3	0.80
40T	0.71	1.4	2.0	2.7	3.3	1.3
50T	1.3	2.3	3.3	4.2	5.2	2.0
65T	2.7	4.4	6.0	7.7	9.3	3.3
80T	2.9	5.4	7.9	10	13	5
65F	3.2	4.9	7.5	8.2	9.8	3.3
80F	4.4	6.9	9.4	12	14	5.0
100F	6.5	10.5	14.4	18	22	7.9

NOTE: T = Thread

F = Flange

V_{0m} = volume of 2 valves with L= 0 m

IMPORTANT

The total volume V_p has to be calculated with all volumes between the tested valves: internal volumes of valves and all pipes

Calculation examples

Example 1

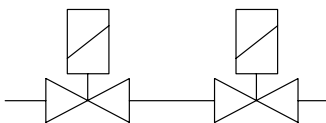

Calculate the maximum pipe length between two 1 1/2" safety valves when an A4021A valve proving system is used with a test period (per valve) of 25 seconds.

Given: P_i = 75 mbar

Q_m = 30 dm³/h

valve: 1 1/2" → DN40

To be calculated: $L(\max.)$ [m]

Calculation:

$$T_p \equiv \frac{2 \times P_i \times V_p}{Q_m} \text{ [s]} \rightarrow V_p \equiv \frac{T_p \times Q_m}{2 \times P_i} \text{ [dm }^3 \text{]}$$

$$V_p \equiv \frac{25 \times 30}{2 \times 75} = 5 \text{ [dm }^3 \text{]}$$

From Table 4. :

DN40T, $V_p = 5 \text{ dm}^3 \rightarrow$ length $L = 2 + (5 - 3.3) / 1.3 = 3.3 \text{ m}$.

Example 2

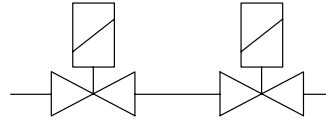

Calculate the test period (per valve) in a given situation.

Given: P_i = 150 mbar

Q_m = 60 dm³/h

valve: VE4065A with 0.5 meter pipe

To be calculated: T_p [s]

Calculation:

From Table 4. :

DN65T, $L = 0.5 \text{ m} \rightarrow V_p = V_{0.5 \text{ m}} = 4.4 \text{ dm}^3$.

$$T_p \equiv \frac{2 \times P_i \times V_p}{Q_m} \text{ [s]} \rightarrow T_p \equiv \frac{2 \times 150 \times 4.4}{60} = 22 \text{ [s]}$$

Choose always a A40121 with a test time (per valve) higher than the (minimum) calculated test time T_p .

Example 3

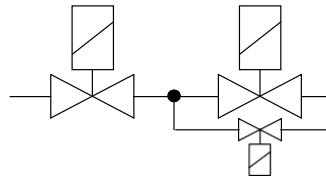

Calculate the test period (per valve) in given situation.

Given: P_i = 150 mbar

Q_m = 100 dm³/h

valve: VE4080A with 1 meter pipe (L1)

pilot valve: VE4025 with 0.5 meter pipe (L2)

To be calculated: T_p [s]

Calculation:

From Table 4. :

DN80T, $L_1 = 1 \text{ m}$

DN25T, $L_2 = 0.5$

$V_p = V_{1 \text{ m}} + (V_{0.5 \text{ m}} - V_{0 \text{ m}}) = 7.9 + (0.44 - 0.19/2) = 8.25 \text{ dm}^3$.

$$T_p \equiv \frac{2 \times P_i \times V_p}{Q_m} \text{ [s]} \rightarrow T_p \equiv \frac{2 \times 150 \times 8.25}{100} = 25 \text{ [s]}$$

Choose always a A40121 with a test time (per valve) higher than the (minimum) calculated test time T_p .



INSTALLATION AND WIRING

Installation

IMPORTANT

1. Read these instructions carefully. Failure to follow the instructions could damage the product or cause a hazardous condition.
2. Before installing or replacing any control check that the test time is correct for the application. Never use a type with a smaller test time than the calculated test time for the application.
3. Check the ratings given in the instructions and on the product to make sure the product is suitable for your application.
4. The installation has to be carried out by qualified personnel only.
5. Carry out a thorough checkout when installation is completed.

Mounting Wiring Subbase

NOTE: For installation dimensions, see Fig. 7.

1. The subbase can be mounted in any position. Make sure that the LEDs indicating the test sequence and faults--causes are clearly visible.
2. Select a location within an electrical panel. Be sure to allow adequate clearance for servicing, installation and electrical field connections.
3. For surface mounting, use the back of the subbase as a template to mark the two screw locations. Drill the pilot holes.
4. Securely mount the subbase using two M3.5 x 0.6 screws.

Wiring



CAUTION

1. Disconnect power supply before beginning the installation to prevent electrical shock, equipment and control damage. More than one power supply disconnect may be involved.
2. Wiring connections are for the A4021A are unique, therefore, refer to Table 3. and Fig. 7. for proper subbase wiring.
3. The A4021A must be installed with fixed wiring for phase and neutral connections.
4. Wiring must comply with all applicable codes, ordinances and regulations.
5. After moving the A4021A valve proving system from outdoor to indoor conditions, condensation may occur. Do not connect condensated valve proving system to mains.
6. The A4021A is not suitable for phase--phase mains., can only be used with phase - neutral mains.
7. For each application diagram, local approval may be needed

General considerations

There are two basic wiring diagrams:

- valve proving before burner start-up: pre--configuration.
- valve proving at end of heat demand: post--configuration.

Wiring

1. For proper subbase wiring, refer to Table 3.
2. Disconnect the power supply from the main disconnect before beginning the installation to prevent electrical shock and equipment damage. More than one disconnect may be involved.
3. All wiring must comply with all applicable electrical codes, ordinances and regulations.
4. Use the COM and NO contacts on both pressure switches (LGPS and GPS).
5. Make sure loads do not exceed the terminal ratings. refer to the label on the valve proving system, or to the ratings in the Specifications, see Table 3.
6. Check the power supply circuit. the voltage and frequency tolerance must match those of the valve proving system. Add the required disconnect means and overload protection.
7. Check all wiring circuits before installing the valve proving system on the subbase
8. Install all electrical connectors.
9. Restore power to the panel.

Pressure switch

The pressure switch can be a normal normally open gas pressure switch which is suitable for the appropriate pressure levels and a voltage of 220 ... 240 Vac. Refer to the enclosed instructions of the pressure switch. The switching point of the GPS must be at 50 % of the nominal line--pressure. Recommended gas pressure switch: C6097A2xxx



GENERAL WIRING DIAGRAMS

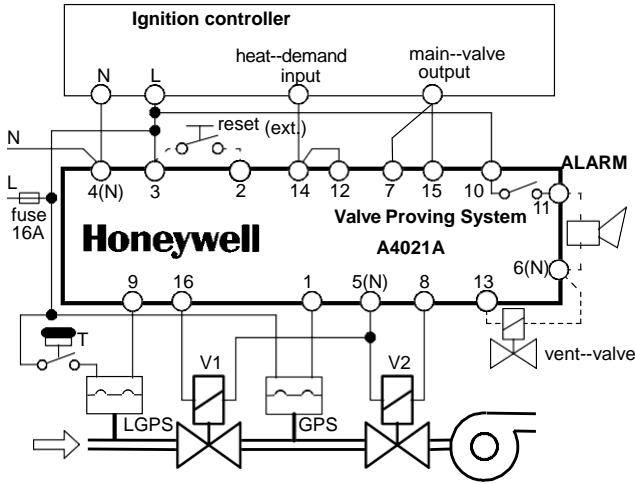

Fig. 10. Wiring diagram for 2--valve configuration pre--configuration

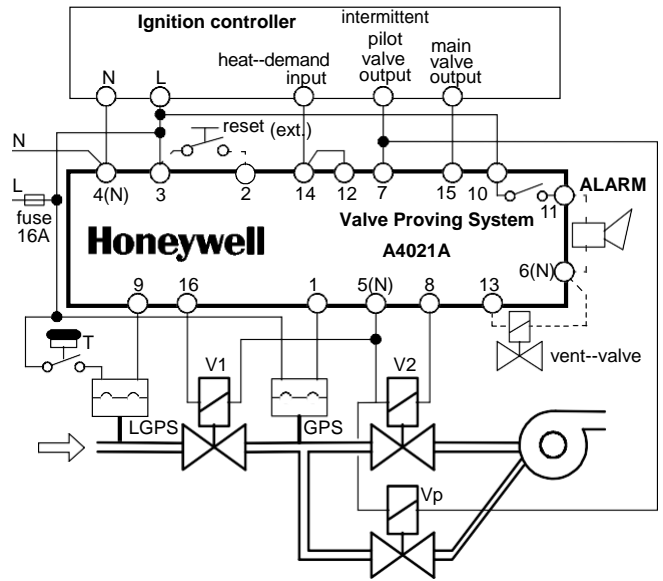

Fig. 12. wiring diagram 3--valve configuration (pre--configuration)

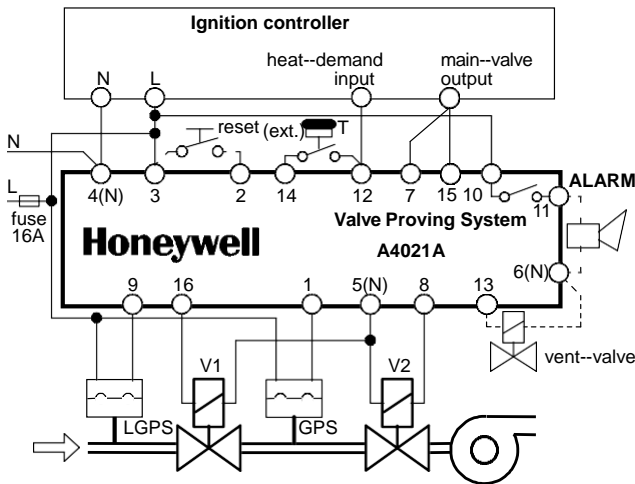

Fig. 11. Wiring diagram 2--valve configuration for post--configuration

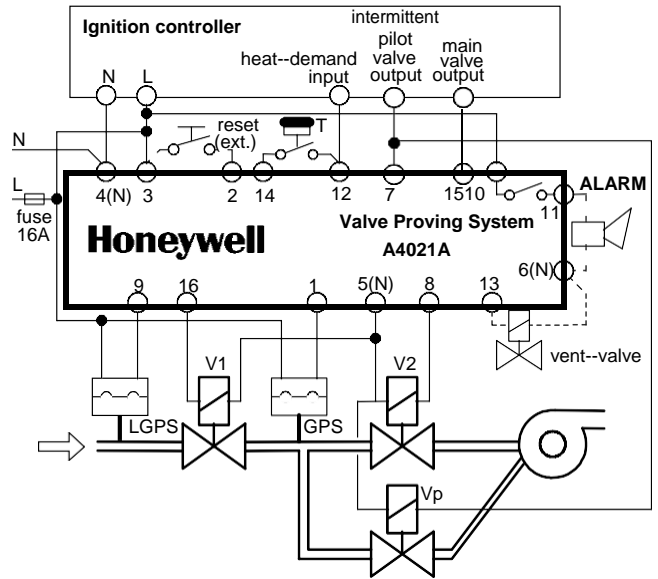

Fig. 13. Wiring diagram 3--valve configuration (post--configuration)

⚠ WARNING

These are general wiring diagram and have not been approved yet by an official approval body. Depending on the application and used ignition controller special wiring diagrams maybe required.



APPLICATIONS WITH EC7850

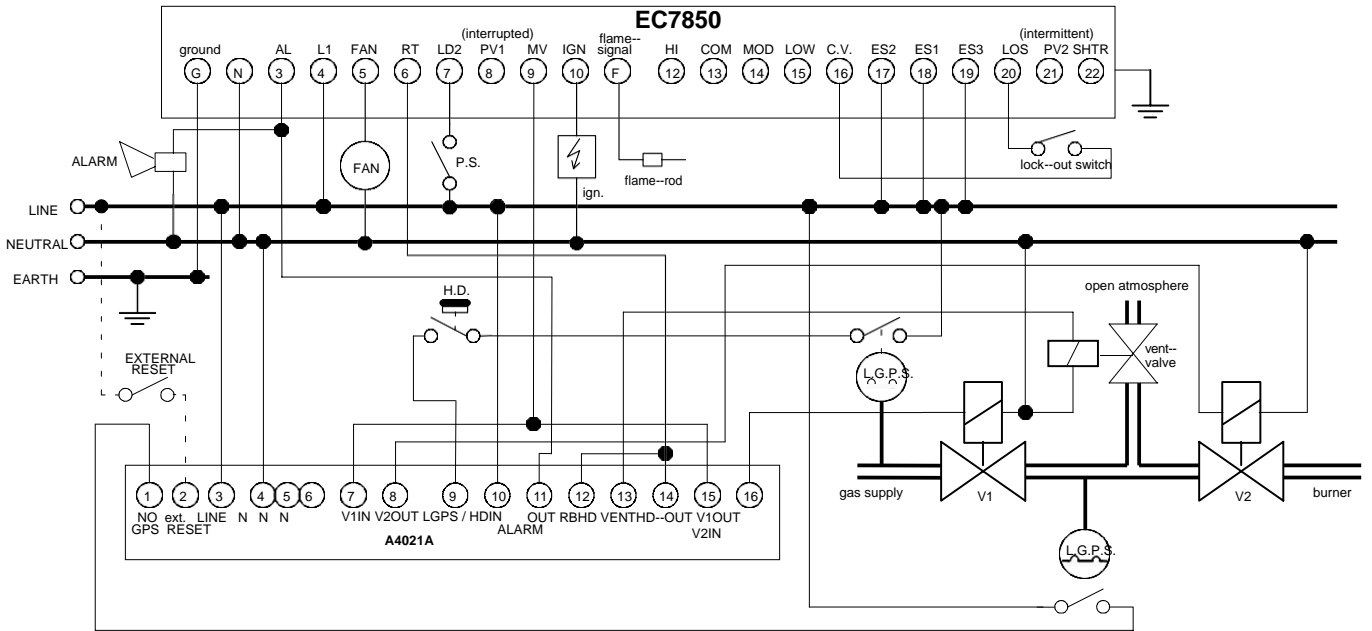
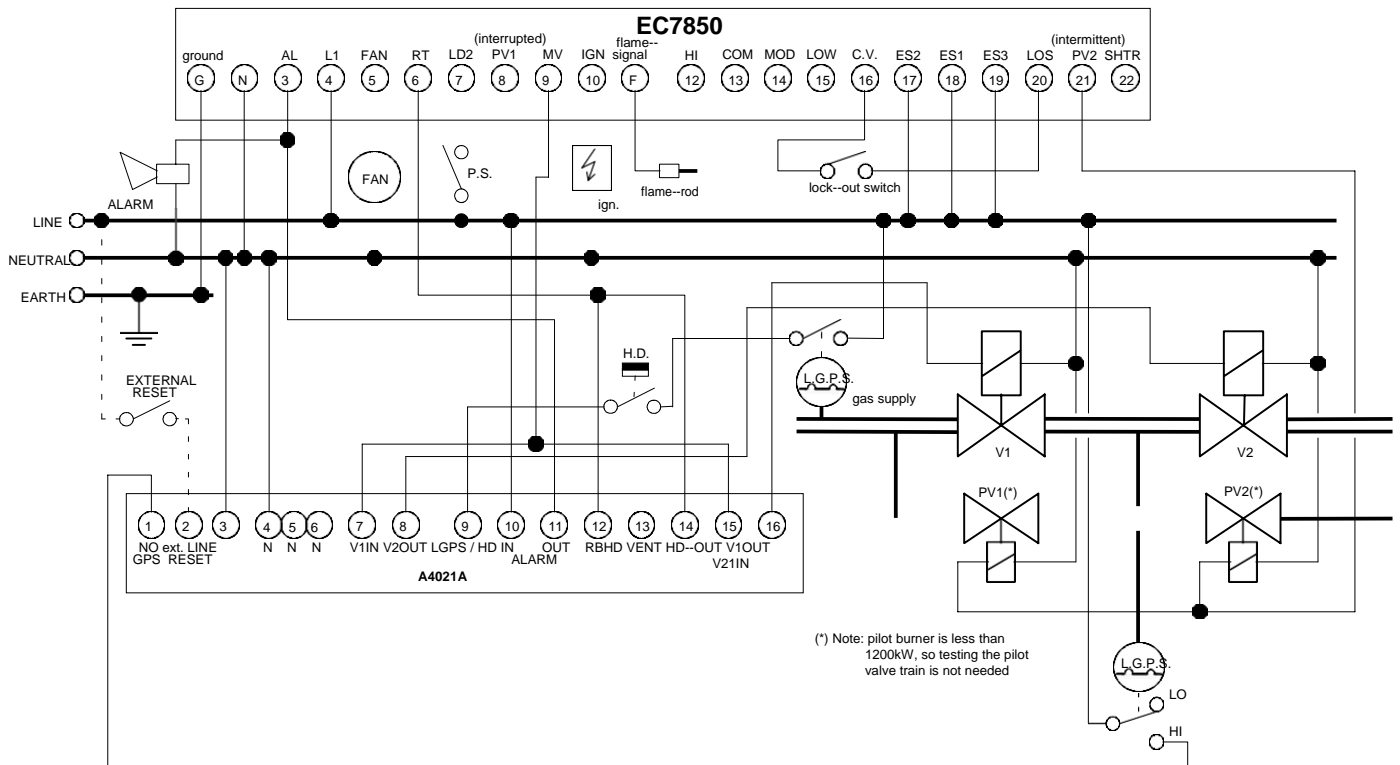

Fig. 14. Wiring diagram A4021A-- EC7850 pre-configuration: intermittent pilot and vent-valve to open atmosphere



(*) Note: pilot burner is less than 1200kW, so testing the pilot valve train is not needed

Fig. 15. Wiring diagram A4021A -- EC7850: pre-configuration, intermittent pilot, 4-valve configuration



WARNING

These are general wiring diagram and have not been approved yet by an official approval body. Depending on the application and used ignition controller special wiring diagrams maybe required.

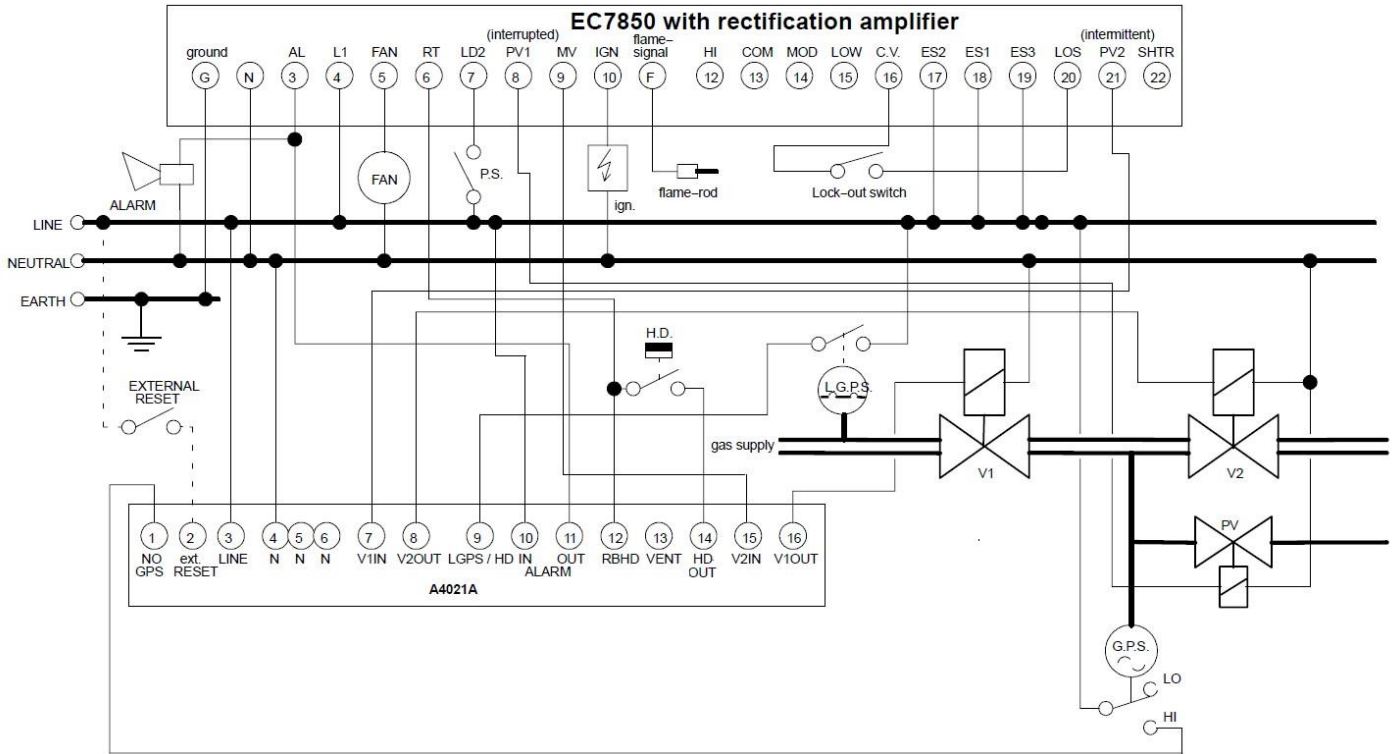

Fig. 16. Wiring diagram A4021A -- EC7850, post--configuration: intermittent system with 3--valve configuration

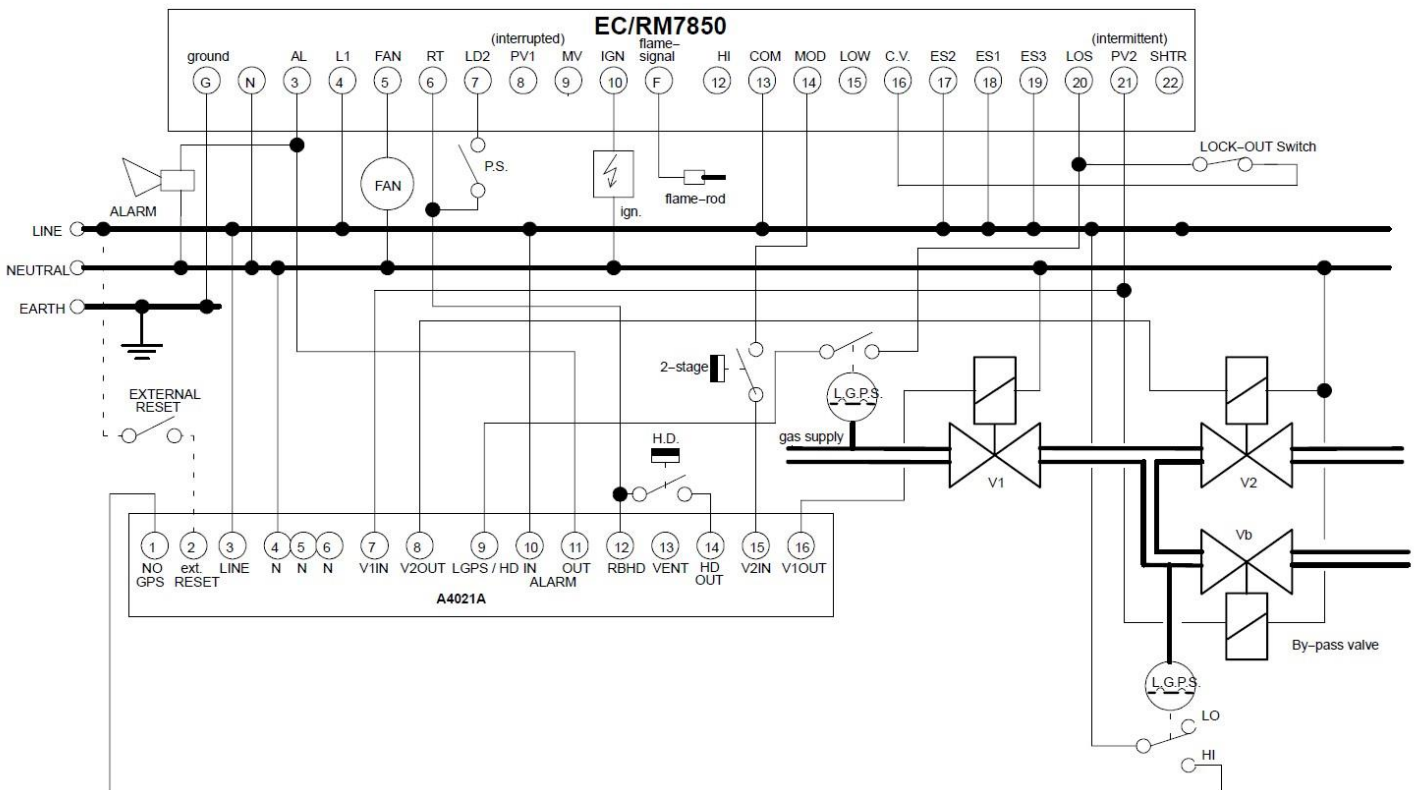

Fig. 17. Wiring diagram A4021A-- EC7850 with by--pass valve, post configuration

WARNING

These are general wiring diagram and have not been submitted for approved by an official approval body. Depending on the application and used ignition controller special wiring diagrams maybe required.

OPERATION

Sequence of operation

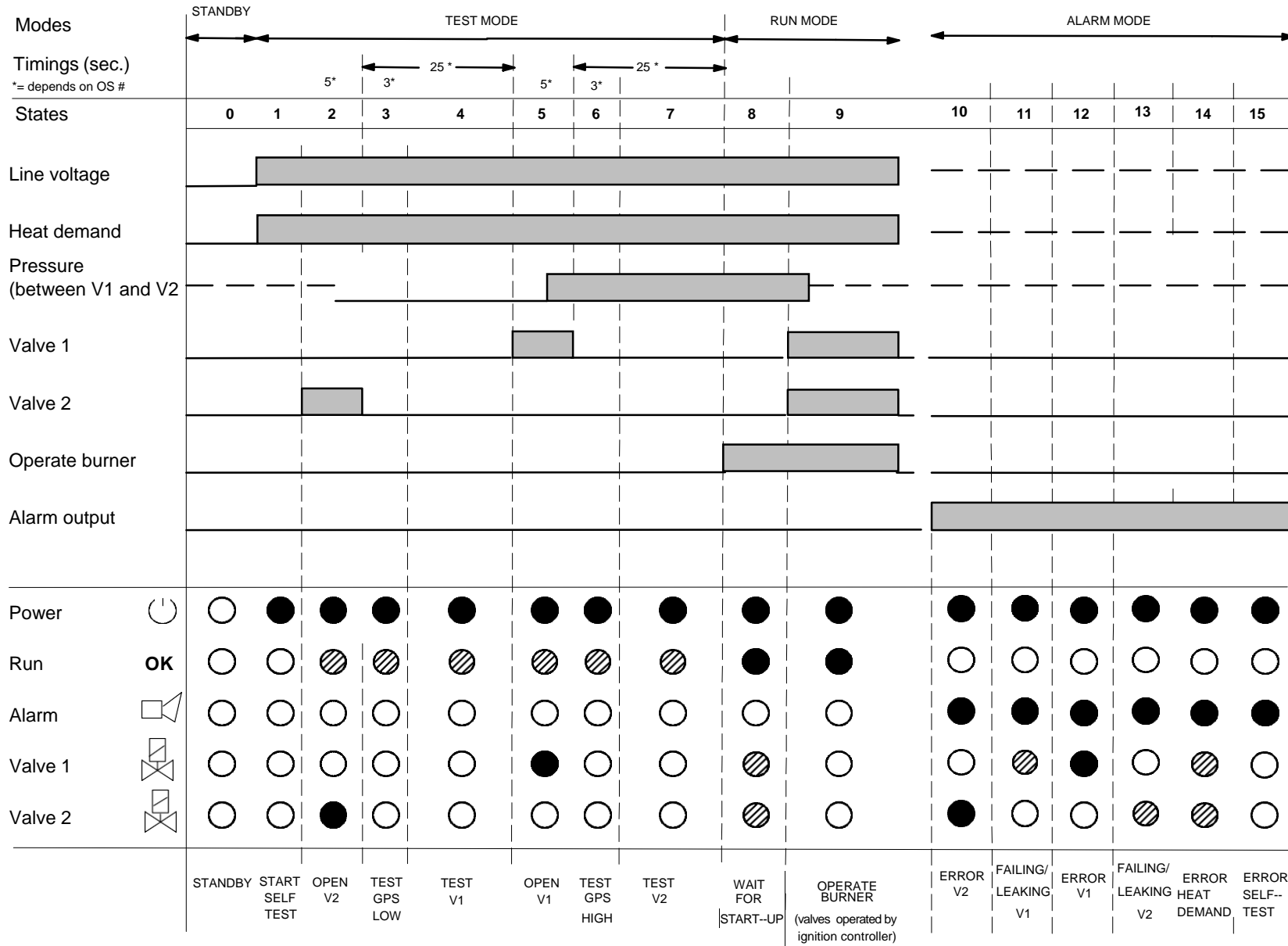

WARNING

No standard valve proving after lock-out of the ignition controller

○ = LED is off	◐ = blinking LED	● = LED on
----------------	------------------	------------



บริษัท เอดีดี เฟอร์เนส จำกัด

ADD FURNACE CO.,LTD.

44 ซอยบรมราชชนนี 70 ถนนบรมราชชนนี แขวงศาลาธรรมสพน์ เขตทวีวัฒนา กรุงเทพฯ 10170

โทร: 02-888-3472 โทร: ออกแบบ:08-08-170-170 แฟกซ์: 02-888-3258

<https://www.add-furnace.com> E-mail: sales@add-furnace.com

CHECKOUT

The procedures described in this chapter are related to A4021A. For adjustments on the other additional functionalities (e.g. pressure switch), refer to the included instruction sheet of the product in question in the package.



WARNING

Phase -- neutral dependency

As the EARTH is not connected to the actual A4021A (earth only connected to the sub--base), it is not possible to detect whether the line and neutral are correct connected on the A4021A.

Exchanged connection of the phase and neutral can lead to hazardous situations, when a short- circuit in one of the valve connections occurs. Therefore the A4021A can only be used with fixed wiring for the line- voltage connections. Make sure that phase and neutral are connected as instructed in the Wiring section.

Final checkout of the installation

Set the appliance in operation after any adjustment and observe several complete cycles to ensure that all burner components function correctly.

Make sure that phase and neutral are connected as instructed in the Wiring section.



TROUBLESHOOTING

! CAUTION

1. Use utmost care while troubleshooting the A4021A, line voltage is present on some of the terminals when power is on.
2. Line voltage is present on the terminals when the cover is removed. Make sure that the main power supply is switched off before removing the cover.
3. The A4021A contains no serviceable parts. Any attempt or replacement of parts (except from internal fuse) will affect the safety of this device and is therefor not allowed.

General

If you encounter a error or fail on V1 or V2, refer to the instruction sheet of the valve.

If you encounter other problems in the system, refer to the Troubleshooting section in the instruction sheet for the appropriate flame safeguard control.

Upon completion of troubleshooting, be sure to perform the Checkout procedures previously specified for the A4021A.

NOTE: Instructions for replacing the cover and fuse are given in the Service section.

Before making a replacement, make sure you have the correct part (check its part number and voltage rating)

Table 5. Troubleshooting A4021A Series valve proving System

States	PWR	RUN	ALARM	V1	V2	Alarm mode	Cause	Action
10	●	○	●	○	●	Error V2	V2 is damaged or V2 is wrong/not connected	Check connections V2 and if necessary replace V2
11	●	○	●	◐	○	Failing/leaking V1	Allowed leak--rate (V1) higher than 0.1% of the maximum flow--rate	Check the gas pressure switch (GPS) and if needed replace V1
12	●	○	●	●	○	Error V1	V1 is damaged or V1 is wrong/not connected	Check connections V1 and if necessary replace V1
13	●	○	●	○	◐	Failing/leaking V2	Allowed leak--rate (V2) higher than 0.1% of the maximum flow--rate	Check gas pressure switch (GPS) and if needed replace V2
14	●	○	●	◐	◐	Error heat demand	Heat demand read--back error .	Check if pin 12 on A4021A is connected
15	●	○	●	○	○	Error self--test	Internal Hardware/Software error	Reset main supply, reset A4021A; if error still occurs: replace A4021A

○ = LED is off

◐ = blinking LED

● = LED on



บริษัท เอดีดี เฟอร์เนส จำกัด

ADD FURNACE CO.,LTD.

44 ซอยบรมราชชนนี 70 ถนนบรมราชชนนี แขวงศาลาธรรมสพน์ เขตทวีวัฒนา กรุงเทพฯ 10170

โทร: 02-888-3472 โทร: ออกแบบ:08-08-170-170 แฟกซ์: 02-888-3258

<https://www.add-furnace.com> E-mail: sales@add-furnace.com

STANDARDS AND APPROVALS

The product is designed according to the following standards:

- EN1643
- ENV 1954
- EN 60730
- EN 60742
- EN 60529 (IP40)

Radio interference protection conform the standards:

- IEC 1000-4-3 (ENV 50140) (immunity to radiation emission)
- IEC 1000-4-6 (ENV 50141) (immunity to injected currents)
- EN 50081-2 (emission industrial level)

- IEC 1000-4-2 (electrostatic discharges)
- IEC 1000-4-5 (surges)
- IEC 1000-4-11 (voltage interruptions and decreases)
- IEC 1000-4-4 (fast transient bursts)

Standards and Approvals (summarized)

The A4021A Series Valve Proving System is conform with the following EC directives:

- Gas Appliance Directive (90/396/EEC)
PIN: CE--0063AS1822
- Low Voltage Directive (73/23/EEC)
- Electro Magnetic Compatibility Directive (89/336/EEC)



บริษัท เอดีดี เฟอร์เนส จำกัด

ADD FURNACE CO.,LTD.

44 ซอยบรมราชชนนี 70 ถนนบรมราชชนนี แขวงศาลาธรรมสพน์ เขตทวีวัฒนา กรุงเทพฯ 10170

โทร: 02-888-3472 โทร: ออกแบบ:08-08-170-170 แฟกซ์: 02-888-3258

https://www.add-furnace.com E-mail: sales@add-furnace.com

ORDERING INFORMATION

When ordering specify:

- Model number
- Voltage

Order separately:

- ZL030001 Subbase.

- C6097A pressure switch.
- 1030002020 Mounting bracket for VQ400/VE5000
- Replacement parts, if desired.

Table 6. Ordering information A4021A Series Valve Proving System.

O.S. Number	Rated Voltage (Vac)	Test time** per valve (s)	Power Consump. (W)	Enclosure*	Functional description				Remarks
					gas pressure switch	3--valve config.	remote reset	alarm output	
A4021A1002	220 ... 240	25	5	IP40	2--wire	yes	yes	voltage free	New ! (without subbase)
A4021A1010	100 ... 120	25	5	IP40	2--wire	yes	yes	voltage free	New ! (without subbase)
ZL030001	100 ... 240	n.a.	n.a.	n.a.	n.a.	n.a.	n.a.	n.a.	Subbase for A4020/A4021A Series

* with ZL030001 subbase

** other test times on request

Honeywell

Honeywell Industrial Combustion

Luchthavenlaan 16

1800 Vilvoorde

belgium

Phone: +32 2 255 09 09

<http://hic.emea.honeywell.com>