



บริษัท เอดีดี เฟอร์เนส จำกัด

ADD FURNACE CO.,LTD.

44 ซอยบรมราชชนนี 70 ถนนบรมราชชนนี แขวงศาลาธรรมสพน์ เขตทวีวัฒนา กรุงเทพฯ 10170

โทร: 02-888-3472 โทร: ออกแบบ:08-08-170-170 แฟกซ์: 02-888-3258

https://www.add-furnace.com E-mail: sales@add-furnace.com

Honeywell

C7061A1020, F1003

DYNAMIC SELF CHECK ULTRAVIOLET FLAME DETECTOR

PRODUCT DATA



model C7061A1020



model C7061F1003

APPLICATION

The C7061A1020 and C7061F1003 are dynamic self-checking flame detectors for sensing the ultraviolet radiation generated by the combustion of gas, oil, or other fuels.

This flame detector is available in two versions:

model C7061A1020 for use in Standard applications, and model C7061F1003 for use in installations requiring explosion-proof packaging. The flame detector is designed for use with either:

R7861A Dynamic Self-Check Ultraviolet amplifier and,
• 7800 SERIES Burner Programmers

R8001S1071 Dynamic Self-Check Ultraviolet Module and,
• SLATE Burner Management System

These configurations provide a closed-loop, self-checking circuit, which ensures the integrity of both amplifier and flame detector. Improper response simulated flame loss results in a safety shutdown and/or alarm.

CONTENTS

GENERAL

Description	2
Features	2
Ordering information.....	2

TECHNICAL DATA

Specification	3
Standards and approvals.....	4
Replacement parts and accessories.....	4
Dimensional drawing	5

INSTALLATION AND OPERATION

Planning the installation.....	6
Installation	8
Wiring	10
Adjustment and checkout	12

VARIOUS

Troubleshooting	13
Service	14
Disposal	15



Only with R7861A or R8001S1071 Amplifier

EN1C-0015 R2105



GENERAL

DESCRIPTION

The C7061A1020 and C7061F1003 detector models are identical except for housings.

Model C7061F1003 detector is for use in installations requiring explosion-proof packaging. The housing is conforming the EExd IIC T6 classification. More details for the explosion proof housing can be found in the chapter Standards and Approvals.

The C7061F1003 model has a 1-inch NPT tapping for mounting onto a sight pipe. For allowable mounting positions of model C7061A1020 and model C7061F1003, see Page 9.

The terminal block on both models is of wire clamp type with removable screws and is situated in the compartment of the C7061. The UV cell contains an ultraviolet sensing tube, shutter assembly, terminal block and magnifying lens.

The UV sensor can be mounted from the flame safeguard device up to an average length of ca. 30m. This also depends on the flame signal strength that is measured on the flame safeguard device (min. 2Vdc for SLATE and 1.25Vdc for 7800-series). A cable that is chosen too long weakens the flame signal and may cause nuisance flame failures, resulting into a safety shutdown of the burner. Using a shielded cable (only connect to ground on controller side, i.e., terminal G) always helps to reduce noise. Avoid running flame sensor cables in parallel with "noisy" cables, like power supply cables or ignition

FEATURES

- Oscillating shutter interrupts ultraviolet radiation reaching the UV Sensor 12 times per minute (when used with R7861 amplifier in combination with 7800 SERIES) to provide the UV Sensor tube checking function. Amplifier circuitry components are checked from the microprocessor in the 7800 SERIES Control.
- Detectors can be mounted horizontally, vertically or at any angle in between. The self-checking C7061 models require faceplate alignment and have integral locating reference points to assure proper operation of the shutter mechanism.
- Ultraviolet radiation sensing tube and quartz viewing window are field replaceable.
- Two flame detectors can be wired in parallel to reduce nuisance shutdowns in difficult flame sighting applications.
- A swivel mount is available to facilitate flame sighting
- -40°C (-40°F) rated ultraviolet sensing tube is available.
- Incorporates UV Sensor tube checking feature; used with R7861 and SLATE Dynamic Self-Check amplifiers.
- High pressure 50 psi (345 kPa) quartz viewing window, magnifying lens and antivibration mount are available as accessories.
- Housing meets IP67 enclosure standards.
- C7061F1003 only: explosion-proof housing, meets EExd IIC T6 classification.
- Protective heat block built into mounting flange.

ORDERING INFORMATION

When ordering specify:

- Complete model number.

Order separately:

- R8001S1071 Dynamic Self-Check Ultraviolet Module.

- R7861A Dynamic Self-Check Ultraviolet Amplifier.
- Replacement parts, if desired.
- Accessories, if desired
- Flame safeguard control



TECHNICAL DATA

SPECIFICATION

Models

C7061A: Self-checking UV flame detector in standard housing.

C7061F: Self-checking UV flame detector in explosion proof housing. Designed for use with:

- SLATE with R8001S1071 Flame Amplifier Module, or
- 7800-series with R7861 Flame Amplifier

Ambient Operating temperature ratings

C7061A -40°C to +70°C (-40°F to +160°F)
(derate ambient 1°F for every 13°F of aspirator temperature over 160°F).

C7061F: -20°C to +70°C (-22°F to +160°F)

Storage temperature ratings

- -51°C to +85°C (-60°F to +185°F)

Voltage and Frequency (applies to shutter)

C7061A1020 115/230 VAC, 50/60

Hz C7061F1003 115/230 VAC, 50/60

Hz

The System operates correctly at a nominal voltage (-15%,

Flame Signal

Measured at the flame signal terminals or via a display.

SLATE: 2.0 to 8.0 Volts

R7861A: 1.25 to 5.0 Volts

Flame Signal amplifier

R8001S1071 Dynamic Self-Check Ultraviolet Amplifier Module

R7861A1026, 1034 Dynamic Self-Check Ultraviolet amplifier (Order separately)

Interchangeability

Models C7061A1020 and C7061F are **not** interchangeable with

Shutter frequency

0.2 Hz, nominal. Interrupts the line-of-sight of the detector about 12 times per minute to provide self-checking. Any malfunction in the flame detection system results in a safety shutdown.

Pressure rating of quartz viewing window

C7061A1020: 138 kPa (20 psi) maximum.

C7061F1003: 690 kPa (100 psi) maximum

Dimensions

C7061A1020: see figure 1.

C7061F1003: see figure 2.

Housing

C7061A1020:

Construction: cast-aluminum cover.

Color: Violet.

Mounting flange (with heat block) and faceplate are separate to provide heat insulation and seal-Off.

C7061F1003:

Meets requirements (explosion-proof): EEx d IIC T6
Construction: cast-aluminum Cover

Color: Violet. Mounting flange (with heat block) and faceplate are separate to provide heat insulation and seal-Off.

Enclosure

C7061A1020:

Meets IP66 enclosure requirements (indoor, outdoor protection; rain-tight, dust-tight, hose-directed water).

C7061F1003: IP65 according to DIN 40050

Weight

C7061A1020: 3.3 kg (7.3 lb)

C7061F1003: 6.3 kg (13.9 lb)

Mounting and orientation

C7061A: Mounting flange with 1-inch NPT internal threads for attaching to sight pipe, including

1 to 3/4-inch adapter bushing for 3/4-inch mount

C7061F: Mounting flange with 1-inch NPT internal threads for attaching to sight pipe.

For allowable mounting positions of model C7061A and F, see Page 9.

Wiring Connections

C7061A1020:

Terminal block

Threaded lead wire opening in faceplate:

1/2-14 NPSM internal threads for attaching conduit.

One brass cable gland standard with housing.

C7061F1003:

Terminal block:

Terminal block inside the housing, wire clamp type, removable screws (terminal lugs can be used).

Cable entry holes:

One brass cable gland Ex classification: EEx d IIC, is standard provided in the housing.

Inner sheath diameter 6 to 12 mm

Outer sheath diameter 8.5 to 16 mm

Tightening torque:

- cable gland into rear cover plate: 20Nm
- cap into cable gland: 3Nm

Serviceability

Field replaceable viewing window and ultraviolet sensing tube, coil and shutter assembly.

Maximum cable length

30-50 m between sensor and amplifier, depending on local conditions (presence of noise, parallel cables, etc.)

Design life

Ultraviolet sensing tube: 40,000 hours continuous operation.



STANDARDS AND APPROVALS

Models C7061A1020 and F1003

C7061A1020 and F Ultraviolet Flame Detector conform with following EC-Directives:

- Gas Appliance Regulation 2016/426/EU. according to European Standard: EN 298:2012 approved with R7861A1026, A1034 and R8001S1071 flame amplifiers.
- Low Voltage Directive 2014/35/EU according to European Standard: EN60730-2-5
- Electro Magnetic Compatibility Directive 2014/30/EU according to European Standards: EN55011 class B regarding emission. EN50082-2 industrial level regarding immunity.

Model C7061F1003

In addition to above information, C7061F1003 conforms with:

- Explosive Atmospheres Directive (94/9/EC) according to European Standards:
EN50014
EN50018
EN50019

REPLACEMENT PARTS AND ACCESORIES

Replacement parts for model C7061A1020 and C7061F

129464N Ultraviolet Sensing Tube; for -40°F (-40°C) operation.

Replacement parts for model C7061A

- 114372 Quartz Viewing Window; rated for 20 Psi (138 kPa).
- 114465 Gasket, silicone rubber; for installing viewing window (three required).
- 120739 Gasket, fiber-neoprene; heat insulation and seal-off for mounting flange.

Accessories for model C7061A1020 and

- 124198 Mounting Flange, aluminum, with 1- inch NPT internal threads for attaching to sight pipe.
- 124204 Quartz Focusing Lens rated for 20 Psi (138 kPa); for increasing the detector-sensed ultraviolet radiation. Included in C7061F1003.

Accessories for model C7061A

- 122748 Quartz Viewing Window rated for 50 Psi (345 kPa).



DIMENSIONAL DRAWING

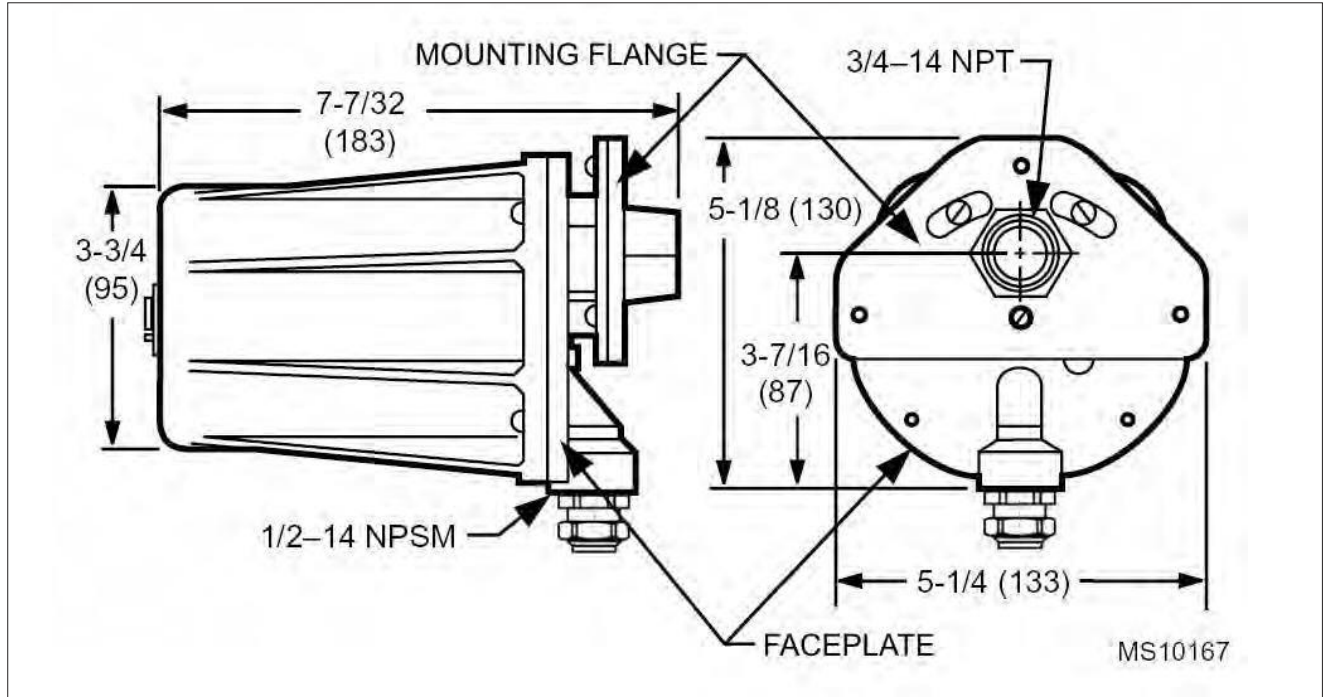

Fig. 1. Dimensional drawing C7061A1020 in inches (mm)

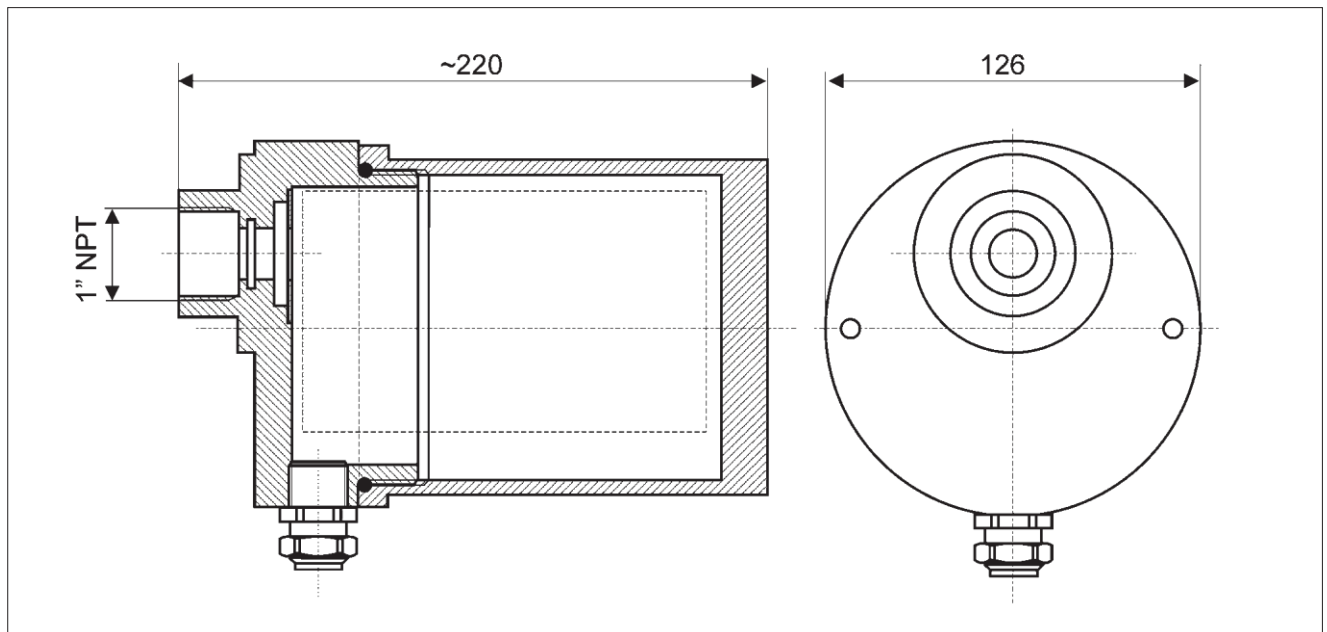

Fig. 2. Dimensional drawing C7061F1003 in mm



Important: See also remarks about mounting positions on page 9.

C7061A: Arrow on face plate must point downwards.

C7061F: Rivet on housing must point upwards.



INSTALLATION AND OPERATION

PLANNING THE INSTALLATION

Proper flame detector application is the back of a safe and reliable flame safeguard installation. Refer to the burner manufacturer's instructions as well to those included here. Follow all instructions carefully.



CAUTION

1. Do not connect these detectors to non-Honeywell manufactured controls (primaries, programmers, multiburner systems, and burner management systems). Unsafe conditions could result.
2. Disconnect power supply before beginning installation to prevent electrical shock and equipment damage. More than one disconnects may be involved.
3. All wiring must be NEC Class 1 (line voltage).
4. Voltage and frequency of the power supply-connected to this detector must agree with the values marked on the detector.
5. Sight the detector so it does not respond to ignition spark.
6. On multiburner installations, each detector must respond only to the flame of the burner it is supervising.



IMPORTANT

Do not connect more than two C7061A/F flame detectors in parallel.

Basic Requirements

The combustion flames of most carbon-based fuels emit sufficient ultraviolet radiation to enable the C7061A/F Solid State (Purple Peeper) ultraviolet flame detector to prove the presence of a flame in a combustion chamber. The detector mounted outside the combustion chamber. Its mounting flange or union is threaded to one end of a sight pipe inserted through the wall of the combustion chamber. The ultraviolet sensing tube in the flame detector sights the flame through the pipe.

When a flame is present, the UV tube in the C7061A/F senses the ultraviolet radiation emitted. The C7061A/F produces a signal that is sent to the amplifier in the flame safeguard control. The amplified signal pulls in the flame relay in the control to allow proper operation of the system.

Because it is necessary for the UV sensing tube to actually see the flame, it is best to locate the detector as close to flame as physical arrangement, temperature, and other restrictions permit. These restrictions are described in detail in the following paragraphs.

Determine the location

Before beginning the actual installation, estimate the best location for mounting the detector based upon these factors:

1. Temperature

Install the flame detector where the surrounding temperature will remain within the specified ambient operating temperature ratings.

For the C7061A/F, to keep the detector temperature within specification. If the temperature rating is exceeded, the introduction of cooling air will be necessary.

2. Vibrations

Do not install the detector where it could be subject of excessive vibration; it shortens the life of the electronic components. Vibrations with a magnitude greater than 1g will require an anti-vibration mount to cushion the detector.

3. Clearance

Make sure there will be enough room to remove the cover of the detector for servicing.

Radiation sources other than flame

Examples of radiation sources, other than a flame, which could actuate the detection system:

Ultraviolet sources

- Radiant surfaces above 1200°C (2200°F).
- Sparks from ignition transformers and welding arcs.
- Gas lasers
- Sun lamps
- Halogen lamps
- Germicidal lamps
- incandescent lamps held close to the sensing tube
- Filament above 1200°C (2200°F).

Gamma ray and X-ray sources

- Diffraction analyzers
- Electron microscopes
- Radiographic X-ray machines
- High voltage vacuum switches
- High voltage condensers
- Radioisotopes

Except under very unusual circumstances, none of these sources, except a radiant surface or ignition spark, would be present in or near the combustion chamber. The detector may respond to a radiant surface at a temperature above 1200°C (2200°F) if both of the following conditions are present the surface represents a significant percentage of detector's field of view.

If the temperature or a radiant surface causes the flame relay (in the flame safeguard control) to pull in, re-aim the sight pipe so the detector views a cooler area, or the sensitivity of the detector decreases. Ignition sparks is a rich source of ultraviolet radiation.



IMPORTANT

When installing the detector, make sure it does not respond to ignition spark.

Single burner requirements

The detector must have an unobstructed view of the flame it is supervising under all firing conditions. This implies a proper sighting angle and the minimization of screening effects.

Sighting angle

The first 30 percent of a flame (the root) radiates the most intense ultraviolet energy. The low angle sighting permits the detector to view a greater depth of the flame root, thus reducing the effects of irregularities in the flame pattern. The best sighting angle is nearly parallel to the axis of the flame, as shown in Figure 3.

NOTE: When possible, it is desirable to tilt the detector and sight pipe downwards to prevent the build-up of soot in the pipe or on the viewing lens.

In most installations, the detector will need to respond to the pilot flame alone, then to the pilot and main burner flame together and finally to the main burner flame alone. The detector must meet all sighting requirements which apply:

1. Pilot flame alone - the smallest pilot flame that can be detected must be capable of reliable ignition the main burner.
2. Pilot and main burner flame together - the detector must sight the junction of both flames.
3. Main burner flame alone - the detector must sight the most stable part of the flame or all firing rates

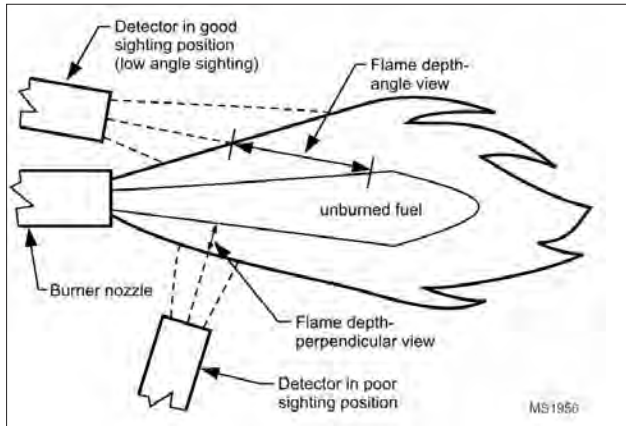

Fig. 3. Sighting angle

Screening effects

Smoke, fuel mist, dirt and dust are masking agents that absorb ultraviolet radiation from the flame. They create a screen that reduces the amount of ultraviolet radiation reaching the detector and may cause flame signal deterioration resulting in a shutdown. The adverse effects of Screening may be minimized by proper burner adjustment, increasing the detector viewing area (shorten sight pipe and/or increase its diameter).

Multifuel requirements

In addition to meeting the requirements for a single burner, a multiburner installation also requires flame discrimination. Flame discrimination may be defined as the location of all flame detectors such that each detector responds only to the flame(s) produced by the burner it is supervising.

Multiburner requirements

In multiple burner systems, not every detector can be positioned so its line of sight does not intercept flames from other burners. This situation occurs in front-fired boiler furnaces having more than one row of burners, or in multi-level opposed-fired furnaces where the burners face each other. When planning such an installation, locate each flame detector so that it has the best possible view of the root of the flame(s) it is supervising and the worst possible view of all other flames.

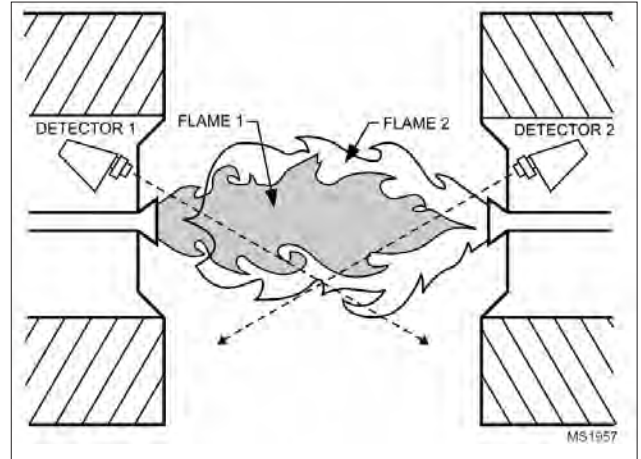

Fig. 4. Critical detector application problem

Figure 4. illustrates a critical detector application Problem requiring flame discrimination. Flame discrimination is accomplished by detector 1 by reducing its sensitivity until the flame relay (in the flame safeguard control) does not respond to flame 2. Note that detector 1 is aimed at the root of Flame 1 where UV (ultraviolet) energy is most intensive. Although it sights flame 2 is not aimed at the root of flame 2. The sensitivity of detector 1 is reduced to a point that ensures maximum sensitivity to flame 1 while rejecting flame 2. Similarly, detector 2 is adjusted to ensure maximum sensitivity to flame 2 while rejecting flame 1.

If the sensitivity control on a detector is set at its minimum position and flame discrimination cannot be achieved, insert an orifice plate in the sight pipe. An orifice of the proper diameter will reduce the ultraviolet radiation reaching the detector so that the sensitivity can be adjusted to effect flame discrimination.

Parallel flame detectors

Two C7061A/F detectors can be connected in parallel to the same flame signal amplifier and still provide independent sensitivity adjustment. This capability is particularly useful for multiburner, multifuel applications.

Shifting flame patterns, commonly encountered on burners with wide turndown ratios, may require parallel detectors to prove the flame at the highest and lowest firing rates. In this case, one detector supervises the pilot (interrupted) and both detectors supervise the main burner flame. During the main burner "run" period, either detector is capable of maintaining system operation. In addition to assuring more reliable flame detection, parallel detectors facilitate maintenance during burner operation. Each detector can be removed in turn without shutting down the supervised burner. However, a flame simulating failure occurring in the flame signal amplifier or in either detector will cause a shutdown.



INSTALLATION



CAUTION

1. Installer must be a trained, experienced flam safeguard control serviceman.
2. Disconnect power supply before beginning installation to prevent electrical shock and equipment damage.
3. All wiring must comply with applicable local electrical codes, ordinances, and regulations.
4. Voltage and frequency of power supply connected to this detector must agree with the values marked on the detector.
6. On multiburner installation, each detector must respond only to the flame(s) produced by the burner it is supervising.
7. Do not connect more than two detectors in parallel to a single R7061 or R7861A Dynamic Self-Check Ultraviolet amplifier.
8. Perform all required adjustments and check-out tests after installation is complete.

Install the Sight Pipe

After you have determined the location and sighting angle, select the sight pipe. A black iron pipe with a diameter of at least 1-1/2 in. (38.1 mm) is recommended. Do not use stainless steel or galvanized pipe because they reflect ultraviolet radiation internally and complicate aiming the pipe.

Sight pipes with diameters 2 to 3 in. (51 to 76 mm) produce better results for horizontal rotary burners, which require wide viewing angles. A wide viewing angle can also be obtained by using a short sight pipe.

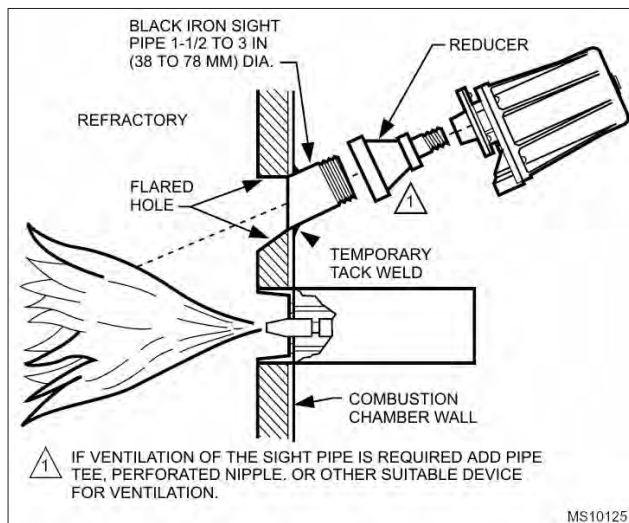

Fig. 5. Typical mounting of C7061A/F

Prepare Hole in Wall of Combustion Chamber

Cut or drill a hole of the proper diameter for the sight pipe in the wall of the combustion chamber at the selected location.

Flare the hole to leave room for small adjustments of the sighting angle. The taper of the hole should be about 1 in. for every 3 in. (25 mm for every 76 mm) of Wall thickness.

Mount Sight Pipe

Thread one end of the pipe to fit the mounting flange, union, or required coupling. Cut the pipe to the desired length (as short as practical) and at an angle so it fits flush with the wall of the combustion chamber. Tack-weld the pipe to the wall in a trial position. Do not weld the sight pipe permanently in place until after completing the Adjustments and Checkout.

Install Fittings

In some cases, the sight pipe does not directly fit the C7061A/F mounting flange or union. Also, it may be desirable or necessary to ventilate the sight pipe. You may also want to use a swivel mount or an antivibration mount. Each of these cases may require additional fitting.

Reducer

For sight pipes of larger diameter than the mounting flange connector or union, install a reducer as illustrated in Fig. 5. The reducer will require a close nipple with these external threads: 3/4 or 1 inch. NPT.

Sight Pipe Ventilation

It may be necessary to ventilate the sight pipe to cool the detector or to clear a viewing path through UV radiation attenuating material.

For a negative pressure combustion chamber, drilling a few holes in the section of the sight pipe outside of the combustion chamber will allow air at atmospheric pressure to flow through the sight pipe and into the chamber. A perforated pipe nipple between the sight pipe and the detector can also be used.

For a positive pressure combustion chamber, connect a supply of pressurized air from the burner blower to flow through the sight pipe and into the chamber. The air pressure must be greater than the chamber pressure.

Swivel Mount (C7061A only)

To facilitate proper flame sighting, use part no. 118367A Swivel Mount (not supplied). The swivel mount requires a reducer of the proper size to mount it onto the sight pipe. It also requires a one-inch close nipple for mounting to a C7061 with a one-inch connector. (For 118367A Swivel Mount mounting details, refer to form 60-0361).

Antivibration Mount

The detector withstands normal burner vibration. If the vibration is excessive, part no. 123539 Antivibration Mount is available. (For mounting details, see form 60-0361). If you use this mount, install it before positioning and sighting the detector.

Mount the Detector

Mount the detector onto the sight pipe, reducer, or other fitting. The C7061A/F Self-Checking flame detectors incorporate an oscillating shutter mechanism and, therefore, require special consideration for mounting positions other than vertically sighting downward or upward, as illustrated in Fig. 6. The C7061A/F has notch and arrow indicators (see Fig. 7 and 9) on the faceplate to facilitate mounting in positions other than those shown in Fig. 7. The notch and arrow must be vertically aligned with the notch in the up position and the arrow pointing downward (see Fig. 7). The C7061A/F must be mounted with the conduit opening located approximately 45 degrees below the horizontal

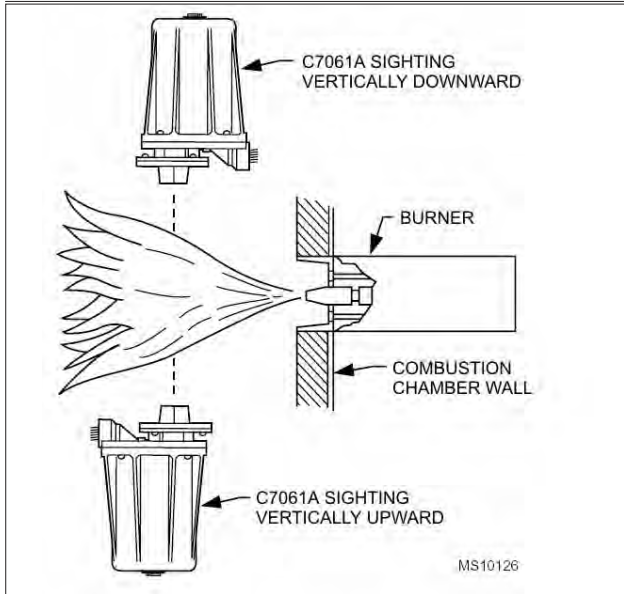

Fig. 6. Vertical mounting of C7061A/F

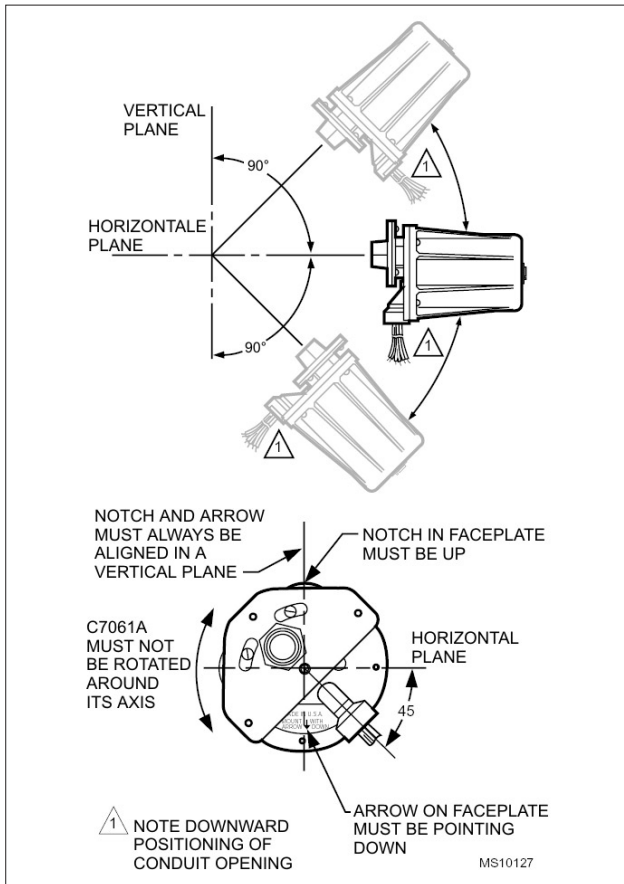

Fig. 7. C7061A mounting Positions



IMPORTANT

The notch and arrow on the faceplate must be aligned in a vertical plane with the notch up and the arrow pointing down.

The housing must be mounted with the conduit opening approximately 45° below horizontal (see Fig. 7)

To mount a C7061A (Fig. 8):

- A The mounting flange is in two pieces. Loosen (but do not remove) the three screws holding the flange together.

- B Slightly rotate the detector so the slots in the back section of the mounting flange clear the screws in the front section; then separate the two sections.
- C Screw the front section of the mounting flange onto the sight pipe, reducer, or other fitting

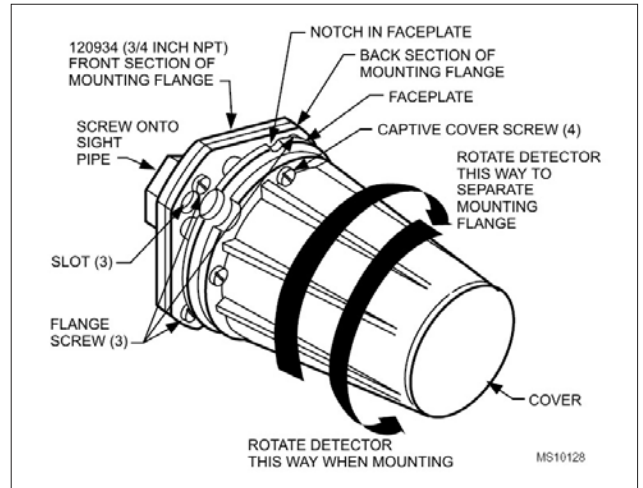

Fig. 8. Mounting the C7061A detector

- D Fit the slots in the back section of the mounting flange (with the detector) over the three screws in the front section and rotate the detector so the screws hold the flange together.
- E Tighten the screws securely.

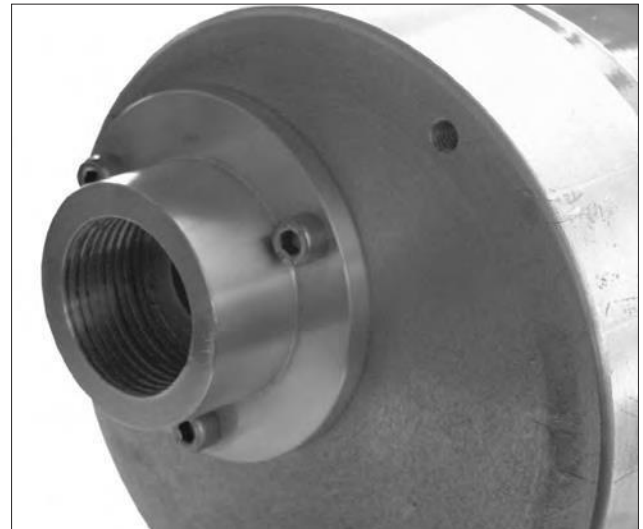
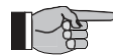

Fig. 9. Mounting the C7061F1 detector



IMPORTANT

The rivet on the faceplate must be at the top (see figure 9). The C7061F can be mounted with increments of 120°.

The C7061F has a rivet on the blank aluminum holder. The cell must be positioned so that this rivet is at the top of the installed cell. In certain applications the sensor must be turned in order accomplish this.

To turn the C7061 (Figure 9).

- A Loose the 3 screws between the pipe connection and bottom part of.
- B Turn the C7061F in the most favorable position. C Tighten the screws securely.



WIRING



CAUTION

When using a C7061A/F with an R7061 or R7861 Dynamic Self-Check amplifier, be careful not to short the white shutter lead wires together (by wiring incorrectly, leaving an incorrect jumper wire, or stripping the insulation too much so the bare lead wires can touch).

If the shutter lead wires are shorted during the operation, the amplifier can be permanently damaged and nonoperative.

1. All wiring must comply with applicable local electrical codes, ordinances, and regulations. Use NEC class 1 wiring.
2. Keep the flame signal lead wires as short as possible from the flame detector to the terminal strip or wiring sub-base. Capacitance increases with lead wire length, reducing the signal strength. The maximum permissible lead wire length depends on the type of lead wire and conduit type and diameter. The ultimate limiting factor in flame signal lead wire length is the signal current.
3. The C7061A/F detectors have a terminal connection block. The wires must be run in a conduit.
4. If the lead wires are not long enough to reach the terminal strip or wiring sub-base, make the required splices in a junction box.
5. If splicing is necessary, use moisture-resistant no. 14 wire suitable for at least 75°C (167°F) if the detector is used with a flame safeguard primary control, or at least 90°C (194°F) if used with a flame safeguard programming control.
6. For high temperature installations, use Honeywell specification no. R1298020 wire or equivalent for the F lead wire. This wire is rated up to 204°C (400°F) for continuous duty. It is tested for operation up to 600 volts and for breakdown up to 7500 volts. For the other lead wires, use moisture-resistant no. 14 wire selected for a temperature rating above the maximum operating temperature.
7. Refer to Fig. 10. for wiring connections



IMPORTANT

Do not run the flame detector wiring in the same conduit with high voltage ignition transformer wires.

Connecting Detectors in Parallel

For a flame that is difficult to sight, using two parallel C7061 flame detectors reduces nuisance shutdowns. If only one of the parallel detectors loses the flame signal, the other indicates the presence of the flame and keeps the burner running. If two parallel C7061A detectors are used, a flame simulating failure in either detector causes the burner to shut down. Two C7061A detectors can be connected in parallel to the same terminals on 120-volt flame safeguard controls.

To avoid exceeding the rating of the solid-state shutter switch in the R7861 flame signal amplifier, do not connect more than two C7061A detectors in parallel.

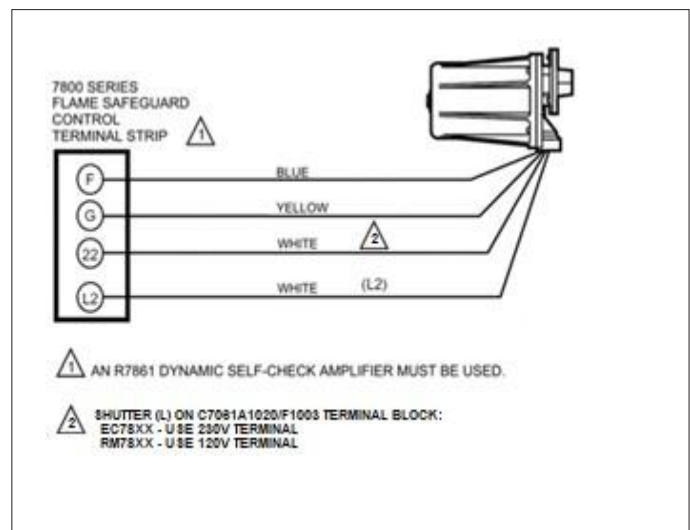
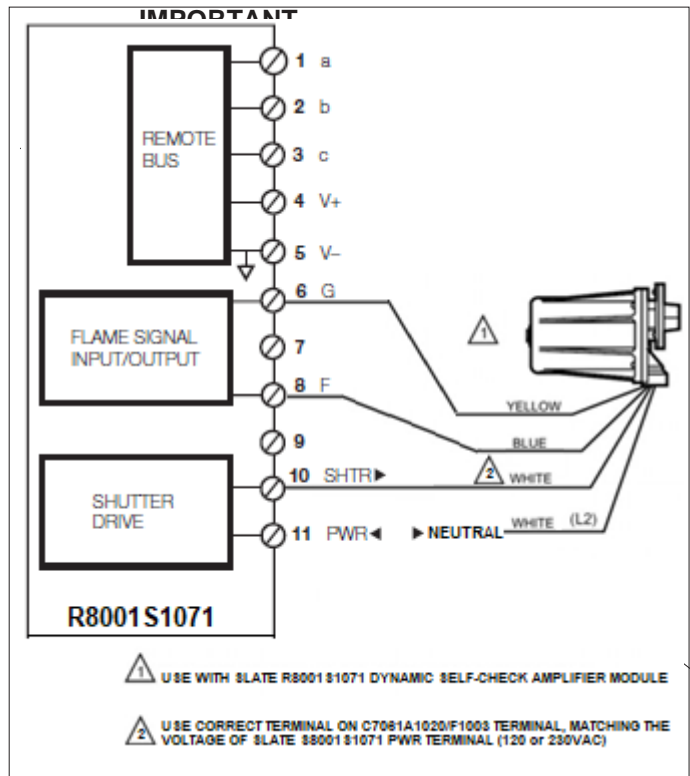

Fig. 10_2. Wiring diagram for C7061A/F detector with SLATE, refer to the SLATE Instruction Sheets.

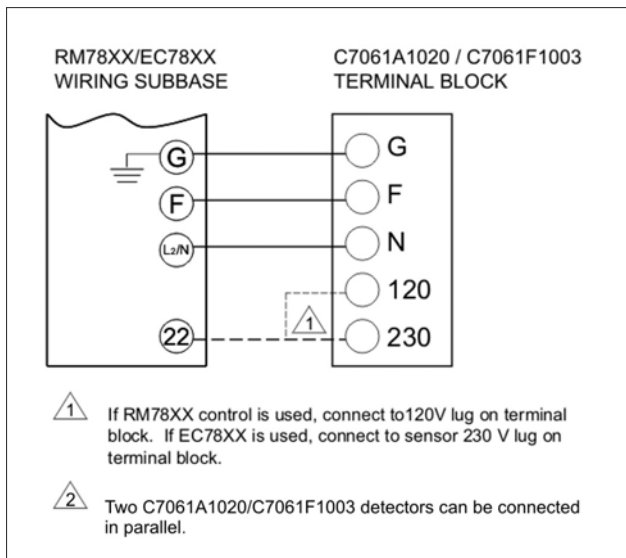

Fig. 10_3. Wiring diagram for C7061A1020/C7061F1003 detector with 7800 SERIES Flame Safeguard controls with shutter drive circuitry.

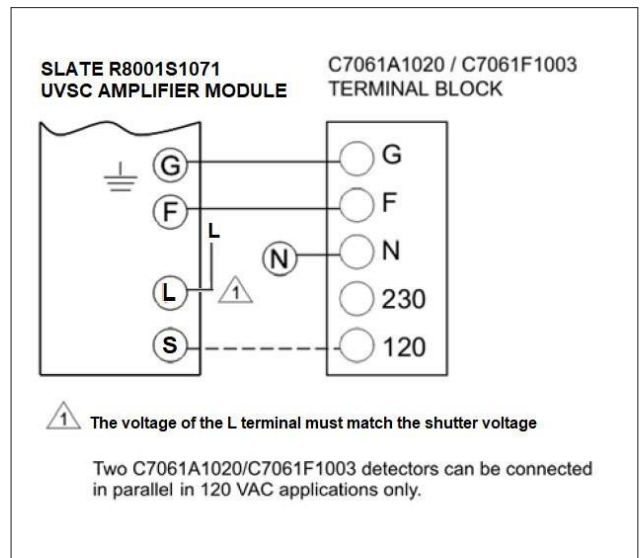

Fig.10_4. Wiring diagram for C7061A1020/C7061F1003 detector with SLATE with shutter drive circuitry.



ADJUSTMENTS AND CHECKOUT

Adjust Detector Sighting

With the flame detector installed and the burner running, adjust the sighting position of the detector for optimum flame signal. It is suggested that a volt-Ohm meter with a minimum sensitivity of one megohm/volt and a zero to five or ten Vdc scale be used for R7861 amplifier flame signal measurements.

Measure the flame signal as illustrated in Fig. 11. Be careful to make the proper connections of positive (red) meter lead to positive (+) control jack and negative (black) meter lead to negative (-) or (-Com) jack with 7800 SERIES controls. When the 7800 SERIES control has the keyboard display module, a zero to five Vdc voltage is displayed on the module. On SLATE devices expect zero to 8 Vdc.

NOTE: The flame Signal must be stable.

Use a multimeter when measuring the flame signal or read the display.

Move the detector and sight pipe around to sight the flame from various positions and angles. Try to get a maximum steady (or stable) reading on the meter. The signal must be above the minimum acceptable voltage listed in Table 1.

Measure the flame signal for the pilot alone, the main burner flame alone, and both together (unless monitoring only the pilot flame when using an intermittent pilot, or only the main burner flame when using direct spark ignition). Also measure the flame signal at low and high firing rates and while modulating in between (as applicable). With the detector in its final position, all required flame signals must be steady (or stable) and as specified in Table 1. If you cannot obtain the proper signal, refer to the



Fig. 11. Measuring voltage flame Signal with 7800 SERIES controls

Table 1. Flame signal

Flame detector	Amplifier	min. acceptable steady signal	max. acceptable steady signal
C7061A1020	R8001S1071	2,0 Vdc	8,0 Vdc
C7061F1003	R7861	1,25 Vdc	5,0 Vdc

Pilot Turndown Test

If the detector is used to prove a pilot flame before the main fuel valve(s) can be opened, perform a pilot turndown test before welding the sight pipe into position. Follow the procedures in the flame safeguard control instructions and in the burner manufacturer instructions.

Ignition Spark Response Test

Test to make certain that ignition spark is not actuating the flame relay in the flame safeguard control.

A Close the pilot and main burner manual shutoff valves.

B Start the burner and run through the ignition period.

Ignition spark should occur, but the flame LED must not light. The flame signal should not be greater than 0.25 Vdc.

C If the flame relay does pull in, reposition the detector farther from the spark, or relocate/resight the detector to eliminate/reduce the detector response to reflected UV radiation. It may be necessary to construct a barrier to block the ignition spark from the detector view. Continue adjustments until the flame signal due to ignition spark is less than the flame signal values

Response to other Ultraviolet Radiation Sources

Some sources of artificial light produce small amounts of ultraviolet radiation. Under certain conditions, an ultraviolet detector responds to them as if it is sensing a flame. Do not use an artificial light source to check the response of an ultraviolet flame detector. To check for proper detector operation, conduct flame failure response tests under all operating conditions.

Weld the Sight Pipe

When the flame signal is acceptable after all adjustments are made, remove the detector, and weld the sight pipe in its final position (if you are using a swivel mount the pipe may already be welded). Then reinstall the detector.

Final Checkout

Before putting the burner into service, check out the installation using the checkout procedures in the instructions for the appropriate flame safeguard control. After completing the checkout, run the burner through at least one complete cycle to verify correct operation.



CAUTION

Do not put the system into operation until all checkout tests in the instructions for the appropriate flame safeguard control and any others specified in the burner installation instructions are satisfactorily completed.



VARIOUS

TROUBLESHOOTING



CAUTION

1. Be extremely careful while troubleshooting the detector: line voltage is present on some of the terminals when power is on.
2. Open the master switch to disconnect power before removing or installing the detector or its cover. More than one disconnects may be involved.

Equipment Required

A volt-Ohm meter with a minimum sensitivity of one megohm / Volt and a zero to five or ten Vdc scale is suggested. When the keyboard display module is available, a flame signal displays on the module. For revision of a flame safeguard control using the R7061 amplifier, use the W136 or a similar test meter. For replacement parts, see specifications section

UV Sensor Tube Test

see UV sensor tube test section.

Unsatisfactory Flame Signal

If a satisfactory flame signal (see Table 1) cannot be obtained while adjusting the sighting position of the detector, follow these procedures. If you encounter other problems in the system, refer to the Troubleshooting section in the instructions for the appropriate flame safeguard control. NOTE: For instructions for replacing the viewing window, sensing tube, and coil and shutter assembly, see the service section.

Troubleshooting Procedures

First perform the preliminary inspection. Then follow the applicable procedures for either a low reading or a zero reading on the meter. After reinstalling the detector or replacing its cover, recheck the meter reading. To try to obtain the proper flame signal, adjust the position of the detector. If you complete all of the procedures and still cannot obtain a proper flame signal, replace the detector.

Preliminary Inspection

- A Check for the proper line voltage. Make sure the master switch is closed, connections are correct, and power supply is of the correct voltage and frequency.
- B Check the detector wiring for defects:
 - a. Incorrect connections.
 - b. Wrong type or size of wire.
 - c. Deteriorated wire.
 - d. Open circuits.
 - e. Short circuits.
 - f. Leakage paths caused by moisture, soot, or dirt.
- C With the burner running, check the temperature at the detector. If it exceeds 79°C (175°F):
 - a. Add additional insulation between the wall of the combustion chamber and the detector.
 - b. Add a shield or screen to reflect radiated heat away from the detector, or
 - c. Add cooling (refer to sight pipe ventilation and accessories sections).

Removing the Detector from the Sight Pipe

C7061A:

Loosen the three screws holding the mounting flange together; rotate the detector slightly so the screws clear the slots in the back section of the flange; separate the flange; and pull off the back section (with the UV Sensor).

NOTE: The detector will be free as soon as the collar is unscrewed; do not drop it.

C7061F:

Carefully unscrew from sight pipe

Procedure for a Zero Meter Reading

- A Replace the plug-in amplifier. Then recheck the flame signal.
- B Replace the ultraviolet sensing tube (see Service section). Then recheck the flame signal
- C Replace the coil and shutter assembly (see Service below). Then recheck the flame signal
- D If you still cannot obtain a meter reading, replace the detector.

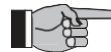

IMPORTANT

At the completion of troubleshooting, be sure to perform the adjustments and checkout procedures.



SERVICE



CAUTION

Open the master switch to disconnect power before removing or installing the detector or its cover. More than one disconnects can be involved.

Periodic Maintenance

- A Clean the viewing window (or focusing lens) when necessary. Remove the detector (see Troubleshooting section) and use a clean cloth over the eraser end of a pencil. Do not remove the window (or lens) to clean it. If it is broken or damaged or it is coated with a substance that cannot be cleaned off, replace it (see Fig. 14).
- B Keep the flame detection system adjusted for the smoothest, most reliable operation as recommended by the burner manufacturer.
- C Replace the sensing tube, coil, and shutter assembly, or viewing window only when necessary, to obtain proper operation.

Removing the Detector Cover

Open the Master Switch

- C7061A: Unscrew the four captive cover screws (Fig. 8 and 9) and carefully slide off the cover.
NOTE: These bolts are removable. Put them in a safe place to avoid losing them.
- C7061F Carefully unscrew the cover from the detector cap.

Replacing the Ultraviolet Sensing Tube

- A Open the master switch and remove the cover from the detector (see instructions above).
- B Locate the UV sensing tube.



IMPORTANT

Be very careful not to kink or otherwise damage the flexible shutter.

- C Gently bend the alignment guide just enough to free the tip
- D of the tube.
Insert a screwdriver between the tube base and socket,
- E and gently pry the tube out of its socket.
- F Pull the tube out of its socket.
Insert the new tube through the openings in the shutter
- G assembly.
- H Align the three pins on the new tube with the holes in the
- H socket.
Carefully push the new tube firmly into its socket; the alignment guide will snap into place around the tip of the
- I tube.
- J Make sure the new UV sensor tube is seated securely.

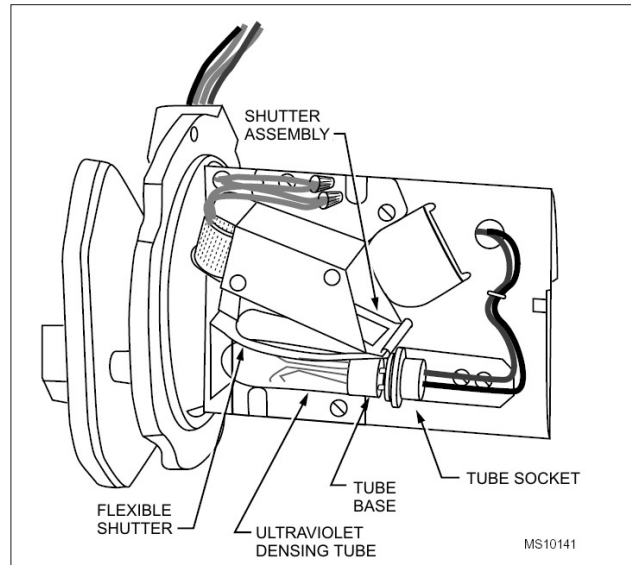

Fig. 12. Replacing ultraviolet radiation sensing tube.

Replacing the Coil and Shutter Assembly

NOTE: Use only a 190971 B coil and shutter assembly.

- A Open the master switch and remove the detector cover (see Removing the Detector Cover section).
- B Remove the ultraviolet sensing tube (steps A through E of Replacing the Ultraviolet Sensing Tube section).
- C Cut the white wires as close as possible to the crimped connectors and remove the crimped connectors.
- D Remove the three mounting screws from the base of the coil and shutter assembly. Put the screws in a safe place.
- E Remove the coil and shutter assembly.
- F Put the new coil and shutter assembly into place.



IMPORTANT

Be very careful not to kink or otherwise damage the flexible shutter.

- G Insert the three mounting screws into the base of the coil and shutter assembly and tighten securely.
- H Remove sufficient insulation from each of the two white lead wires remaining on the detector, and from each of the two white lead wires on the new coil.
- I Using solderless connectors, connect one of the coil wires to one of the remaining white lead wires.
Connect the other coil wire to the other remaining white
- J lead wire. Reinstall the sensing tube (steps F through I of Replacing the Ultraviolet Sensing Tube section).
- K Replace the detector cover.

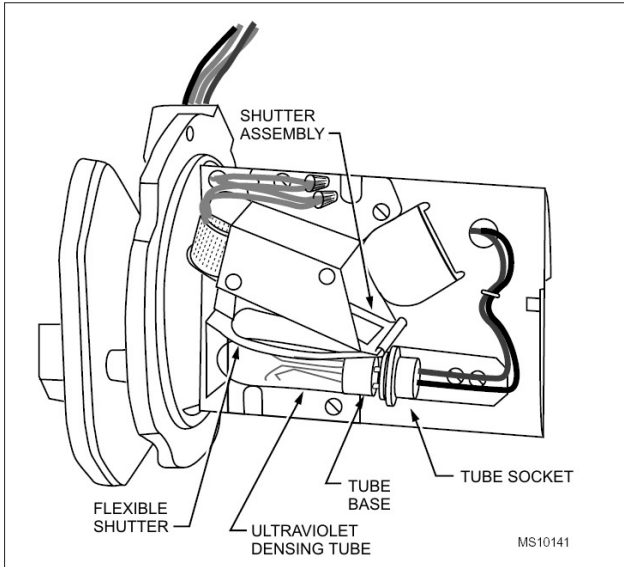

Fig. 13. Replacing coil and shutter assembly.

Replacing the Quartz Viewing Window (or Focusing Lens) C7061A Only



IMPORTANT

A quartz window or lens must be used. Ordinary glass absorbs or filters out ultraviolet radiation.

- A Open the master switch; remove the detector from the sight pipe and remove the detector cover. (see appropriate sections.)
- B Remove the ultraviolet sensing tube (steps A through E of Replacing the Ultraviolet Sensing Tube section).
- C Loosen the three screws holding the back section of the mounting flange to the faceplate. Carefully remove and keep together the three screws, the gray fiber-neoprene gasket, the red rubber washer, and the back section of the mounting flange.

NOTE: if the viewing window (with its rubber mounting gaskets) is stuck to the mounting flange skip step D.



IMPORTANT

Be very careful not to kink or otherwise damage the flexible shutter.

- D Using the eraser end of a pencil, push out the viewing window (with its rubber mounting gaskets) from the inside of the faceplate.
- E Insert one rubber mounting gasket into the window aperture in the faceplate.
- F Insert the new quartz viewing window (or focusing lens).
- G Insert two rubber mounting gaskets (only one gasket when replacing a focusing lens) into the aperture.
- H Put the back section of the mounting flange, rubber washer, and fiber-neoprene gasket in place on the faceplate, and securely tighten the three mounting screws.

NOTE: Make sure the red rubber washer between the gray fiber-neoprene gasket and the back section of the mounting flange does not protrude over the window aperture or otherwise obscure the detector line-of-sight.

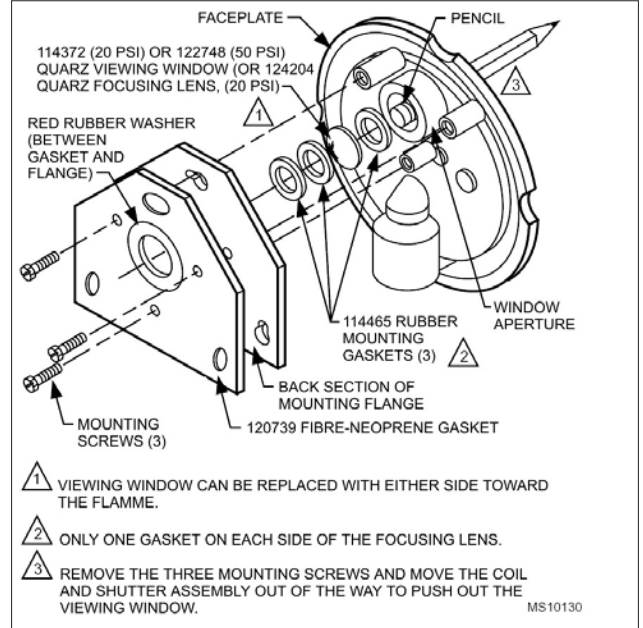
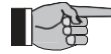

Fig. 14. Replacing quartz viewing window or focusing lens

- I Clean the viewing window (or focusing lens) on both sides using a clean cloth placed over the eraser end of a pencil.
- J Reinstall the sensing tube (steps F through I of Replacing the Ultraviolet Sensing Tube section).
- K Replace the detector cover and reinstall the detector on the sight pipe.

Replacing Focusing Lens C7061F Only



IMPORTANT

A quartz window or lens must be used. Ordinary glass absorbs or filters out ultraviolet radiation.

- A Remove the detector from the sight pipe (see Fig. 15).
- B Remove the 3 screws from the threaded flange (pipe connection) which houses the 124204 Focusing Lens.
- C Replace the lens and tighten the 3 screws.

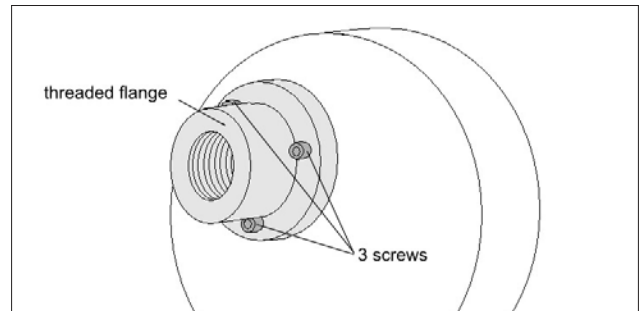

Fig. 15. Replacing focusing lens on C7061F1003



บริษัท เอดีดี เฟอร์เนส จำกัด

ADD FURNACE CO.,LTD.

44 ซอยบรมราชชนนี 70 ถนนบรมราชชนนี แขวงศาลาธรรมสพน์ เขตทวีวัฒนา กรุงเทพฯ 10170

โทร: 02-888-3472 โทร: ออกแบบ:08-08-170-170 แฟกซ์: 02-888-3258

<https://www.add-furnace.com> E-mail: sales@add-furnace.com

DISPOSAL

Devices with electronic components:

WEEE Directive 2012/19/EU – Waste Electrical and Electronic Equipment Directive



At the end of the product life (number of operating cycles reached), dispose of the packaging and product in a corresponding recycling centre. Do not dispose of the unit with the usual domestic refuse. Do not burn the product. On request, old units may be returned carriage paid to the manufacturer in accordance with the relevant waste legislation requirements.

For More Information

The Honeywell Thermal Solutions family of products includes Honeywell Combustion Safety, Eclipse, Exothermics, Hauck, Kromschroder and Maxon. To learn more about our products, visit ThermalSolutions.honeywell.com or contact your Honeywell Sales Engineer.

Honeywell Process Solutions

Honeywell Thermal Solutions (HTS)
2101 CityWest Blvd
Houston, TX 77042
ThermalSolutions.honeywell.com