

R4343D / R4343E

SPECIFICATIONS



MODELS:

Types	Notes	Ffirt *	Supply Voltage
R4343D1009	For rectification type sensor	1 sec.	115 Vac
R4343D1017		1 sec.	230 Vac
R4343D1041	For rectification type sensor, special "Helling logo"	2 sec.	115/230 Vac (dual voltage)
R4343D1041-ST005	For rectification type sensor	2 sec.	115/230 Vac (dual voltage)
R4343E1006	For non-self checking UV sensors (Mini-Peeper)	1 sec.	115 Vac
R4343E1014		1 sec.	230 Vac
R4343E1048	For non-self checking UV sensors (Mini-Peeper), special "Helling logo"	2 sec.	115/230 Vac (dual voltage)
R4343E1048-ST005	For non-self checking UV sensors (Mini-Peeper)	2 sec.	115/230 Vac (dual voltage)

DIMENSIONS

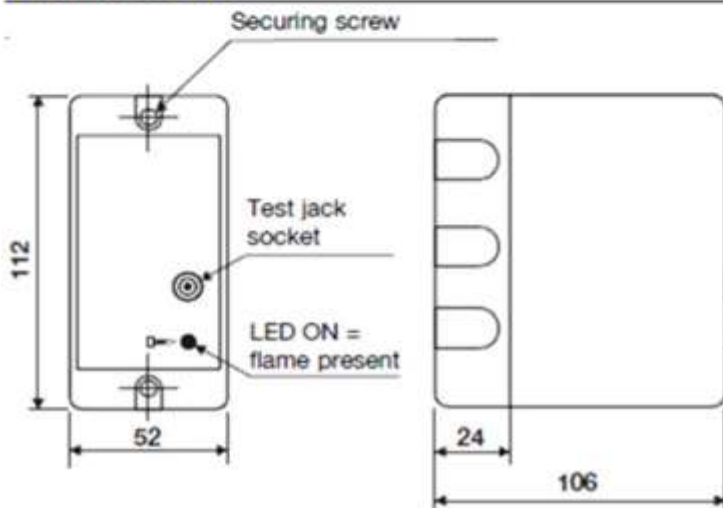

ELECTRICAL RATING:

115Vac, 230Vac (+ 10 % to - 15%),
 50/60 Hz.

CONTACT: 2 Isolated DPDT contacts. Rating: 2A at 0.65 power factor.

AMBIENT TEMPERATURE LIMITS:
 -10 to + 60 °C

MAXIMUM RELATIVE HUMIDITY:
 90% RH at + 40 ° C.

DEGREE OF PROTECTION: IP40

FLAME FAILURE RESPONSE TIME *
 Less than one second (standard models).
 Other timings available on request.

CLASSIFICATION: OOOOON

Mount the subbase

1. The subbase may be installed in any plane, but the vertical is recommended.
2. Ensure that sufficient space is available to access the relay for servicing or removal.

Wire the subbase

1. Wiring and overload protection should conform to local electrical regulations
2. Verify that the wiring is correct before plugging in the relay.

TYPICAL WIRING DIAGRAMS

R4343D (recommended)

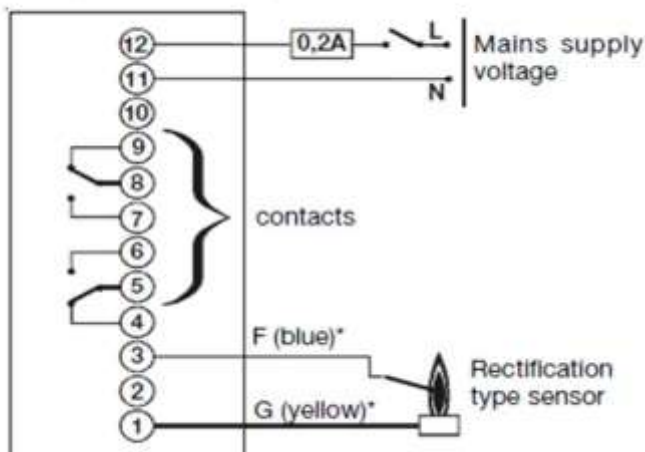

R4343E (recommended)

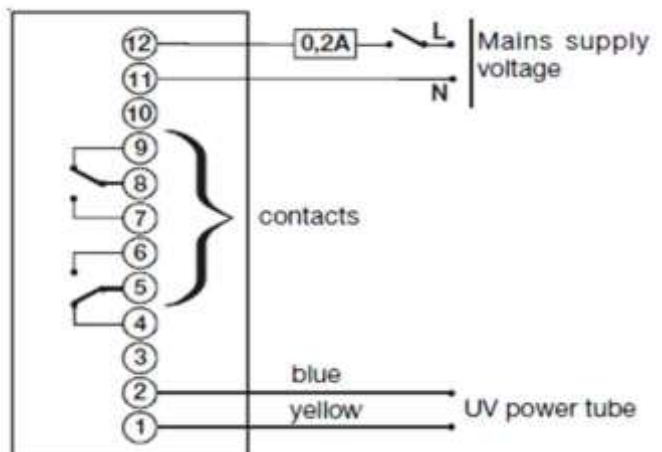

* only for C7012A/C/G

The performance of the relay depends upon how well the flame detector is installed. For guidance on how to properly install a flame detector, consult the burner/boiler manufacturer's instructions and the information packed with the detector.

Flame current check

The test jack on the face of the relay allows the value of the flame current to be easily measured. Use a Honeywell W136A micro ammeter (or equivalent), which has a plug for insertion into the test jack socket.

The expected maximum and minimum values of flame current for the various types of flame detectors are given in the table below together with hints on what to check if the current is unsteady or weak.

Note that the following have an influence on flame detector performance.

- (1) Position, size and burning characteristics of the flame.
- (2) Ambient temperature at the detector (except flame rod). See detector instruction sheet.
- (3) Refractory - When refractory temperature exceeds 1370° C/2500° F, some ultra-violet radiation may occur. Lower refractory temperatures may affect photocells; see relevant data sheets.
- (4) Temperatures of sensor
 Flame rods: ensure suitable rod.
 Other sensors: see relevant data sheets.

Flame detector	Recommended condition	If less than minimum or unsteady*, check for	How to measure
Rectifying Flame Rod C7004B C7005A/B C7007A C7008A C7009A C7011A Q179A/B/C/D	2 - 5µA	Sufficient earthing area Good area connection. Proper positioning of flame rod in flame	Use a Honeywell W136 A micro ammeter or equivalent at meter jack
Rectifying Photocell C7003A C7010A C7013A C7014A	2 - 5µA**	Proper sighting. Clean lens and/or filter.	
Ultraviolet (rectifying) C7012A/C/G	Must be steady. Will be 3 - 6µA microamperes	Proper sighting. Clean lens and/or filter. An unsteady signal indicates the detector is	
Ultraviolet (power tube) C7027A, C7035A, C7044A	Must be steady. Will be 3.5 - 7.5 µA microamperes.	viewing an unstable part of the flame	

* Indicates a marginal installation, a defect in the circuit or a defective component.

** Do not permit signal to exceed 5µA as it could shorten photocell life.