



บริษัท เอดีดี เฟอร์เนส จำกัด

ADD FURNACE CO.,LTD.

44 ซอยบรมราชชนนี 70 ถนนบรมราชชนนี แขวงศาลาธรรมสพน์ เขตทวีวัฒนา กรุงเทพฯ 10170

โทร: 02-888-3472 โทร: ออกแบบ:08-08-170-170 แฟกซ์: 02-888-3258

https://www.add-furnace.com E-mail: sales@add-furnace.com

Honeywell

# Series 61 and Series 62 Modutrol IV™ Motors

## PRODUCT DATA

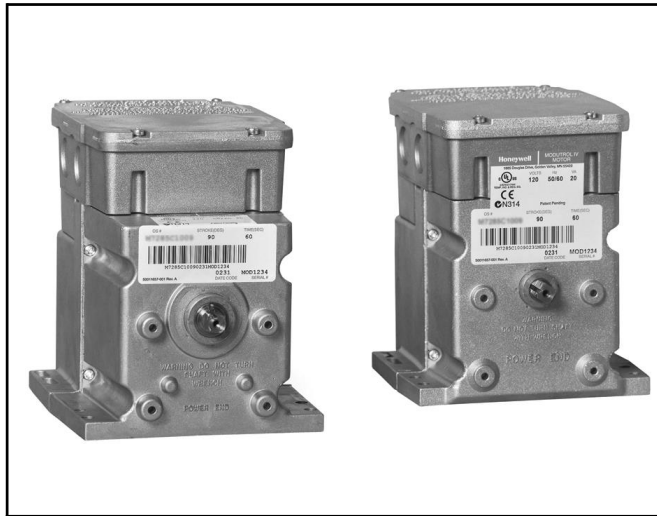

## FEATURES

- Replaces M644, M944B,E,G,H,J,K,R,S and M945B,C,G,K,L,AD Motors.
- Integral junction box provides NEMA 3 weather protection.
- Integral spring return returns motor to normal position when power is interrupted.
- Motor and circuitry operate from 24 Vac. Models available with factory installed transformer, or a field added internal transformer.
- Quick-connect terminals are standard—screw terminal adapter is available.
- Adapter bracket for matching shaft height of older motors is available.
- Motors have field adjustable stroke (90° to 160°).
- Die-cast aluminum housing.
- Integral auxiliary switches are available factory mounted, or can be field added.
- Nominal timing standard of 30 seconds (90° stroke), and 60 seconds (160° stroke). Other timings available.
- Spring return motors can operate valve linkages from power end or auxiliary end shafts for normally closed or normally open valve applications.
- All models have dual shafts (slotted and tapped on both ends).
- All models have auxiliary switch cams.
- Fixed torque throughout the entire voltage range.
- Motors are designed for either normally open or normally closed valves and dampers.
- Series 62 models include electrically isolated feedback potentiometer that provides shaft position indication.
- Series 62 TRADELINE models have linear feedback, configurable for slaving Series 90 Motors.

## APPLICATION

The Series 61 and Series 62 Modutrol IV™ Motors are three-wire spring return and non-spring return floating control motors. Use these motors with controllers that provide a switched spdt or floating output to operate dampers or valves. The Series 62 motors have an internal electrically isolated feedback potentiometer that provides indication of the motor shaft position and can be used for slaving Series 90 Motors or rebalancing an external control circuit.

## Contents

Application .....	1
Features .....	1
Specifications.....	2
Ordering Information .....	2
Installation .....	4
Settings and Adjustments .....	9
Operation .....	11
Checkout .....	11
Replacement.....	11



63-2629-05



บริษัท เอดีดี เฟอร์เนส จำกัด

ADD FURNACE CO.,LTD.

44 ซอยบรมราชชนนี 70 ถนนบรมราชชนนี แขวงศาลาธรรมสพน์ เขตทวีวัฒนา กรุงเทพฯ 10170

โทร: 02-888-3472 โทร: ออกแบบ:08-08-170-170 แฟกซ์: 02-888-3258

https://www.add-furnace.com E-mail: sales@add-furnace.com

SERIES 61 AND SERIES 62 MODUTROL IV™ MOTORS

**SPECIFICATIONS**

**Models:** TRADELINE models are selected and packaged to provide ease of stocking, ease of handling and maximum replacement value. TRADELINE model specifications are the same as those of standard models unless specified otherwise.

**Modutrol IV Order Number Guide:** See Table 1.

**Dimensions:** See Fig. 1.

**Feedback** See Table 2.

**Electrical Ratings:** See Table 3.

**Table 1. Modutrol IV Series 2 Version Order Number Guide.**

M	Motor				
	61	Floating Control			
	62	Floating Control with feedback			
	8	60 lb-in. Spring Return	150 lb-in. Non-Spring Return		
	9	—	300 lb-in. Non-Spring Return		
	2	Dual-ended shaft	Normally Closed Spring Return		
	4		Non-Spring Return		
	5		Normally Closed Spring Return		
	A	0 Auxiliary Switches	Adjustable Stroke	Normally Closed	
	B	1 Auxiliary Switch			
	C	2 Auxiliary Switches			
	D	0 Auxiliary Switch			
	E	1 Auxiliary Switch			
	F	2 Auxiliary Switches			

M	61	8	4	A	XXXX	See Catalog for Complete O.S. Number
---	----	---	---	---	------	--------------------------------------

**Table 2. Series 62 Feedback Characteristics**

OS Number	Feedback Resistance	Sensitivity Adjustment	Internal Shunted	Linear Feedback	Series 90 Slaving Shunt Resistor
M6284D1000-S, M6284D1026-S, M6284D4004-S, M6285A1005-S, M6285A1054-S, M6285A4009-S	600 Ohms	No	Yes	No	187 Ohm
M6274F1009-F, M6284F1070-F, M6284F1078-F, M6285F1001-F, M6294F1009-F, M6294F1017-F, M6284D1032-F	10 K Ohms	No	No	Yes	Not Available
M6284A1071-S, M6284A1089-S, M6284C1028-S	196/346 Ohms	Yes	Yes	No	274 Ohm
M6284A1030-S, M6284A1055-S, M6284A1097-S, M6284B1004-S, M6284C1010-S, M6284C1044-S, M6284F1013-S, M6284F1039-S, M6285A1039-S, M6285A1047-S, M6285C1001-S, M6294B1036-S, M6294D1008-S	119/224 Ohms	Yes	Yes	No	Not Necessary
M6284F1062-S	1800 Ohms	No	Yes	No	Not Available
“-S” Slaving Series 90 Mod IV Motor					
“-F” 0-10K Feedback					

**ORDERING INFORMATION**

When purchasing replacement and modernization products from your TRADELINE® wholesaler or distributor, refer to the TRADELINE® Catalog or price sheets for complete ordering number.

If you have additional questions, need further information, or would like to comment on our products or services, please write or phone:

1. Your local Honeywell Automation and Control Products Sales Office (check white pages of your phone directory).
2. Honeywell Customer Care  
1885 Douglas Drive North  
Minneapolis, Minnesota 55422-4386

In Canada—Honeywell Limited/Honeywell Limitée, 35 Dynamic Drive, Toronto, Ontario M1V 4Z9.

International Sales and Service Offices in all principal cities of the world. Manufacturing in Australia, Canada, Finland, France, Germany, Japan, Mexico, Netherlands, Spain, Taiwan, United Kingdom, U.S.A.



**Table 3. Series 61 and 62 Modutrol IV Motor Power Consumption Ratings.**

Internal Transformer	Voltage at 50/60 Hz	Power Consumption			
		Non-Spring Return		Spring Return	
		(VA)	(W)	(VA)	(W)
No	24	13	6	19	9
Yes	24	13	6	19	9
	120	13	6	19	9
	230	13	6	19	9

**Auxiliary Switch Ratings:** See Table 4.

**Control Inputs:**

Floating three-wire (Series 60): drive open, hold, drive closed. Series 62 models include an internal, electrically isolated feedback potentiometer that provides shaft position indication.

**SERIES 61 AND SERIES 62 MODUTROL IV™ MOTORS**

**Table 4. Auxiliary Switch Ratings.**

Single Contact Rating <sup>a</sup>	120V (in Amps)	240V (in Amps)
Full Load	7.2	3.6
Locked Rotor	43.2	21.6

<sup>a</sup> 40 VA pilot duty, 120/240 Vac on opposite contact.

**Ambient Temperature Ratings:**

Maximum: 150°F (66°C) at 25% duty cycle.

Minimum: -40°F (-40°C).

**Dead Weight Load On Shaft:**

Power or Auxiliary End: 200 lb (90.8 kg) maximum.

Maximum Combined Load: 300 lb (136 kg).

**Crankshaft:** 3/8 in. (9.5 mm) square.

**Stroke:** Adjustable Stroke Models: Available field-adjustable from 90° to 160°. (See Stroke Setting procedure.)

**Timing And Torque:** See Table 5.

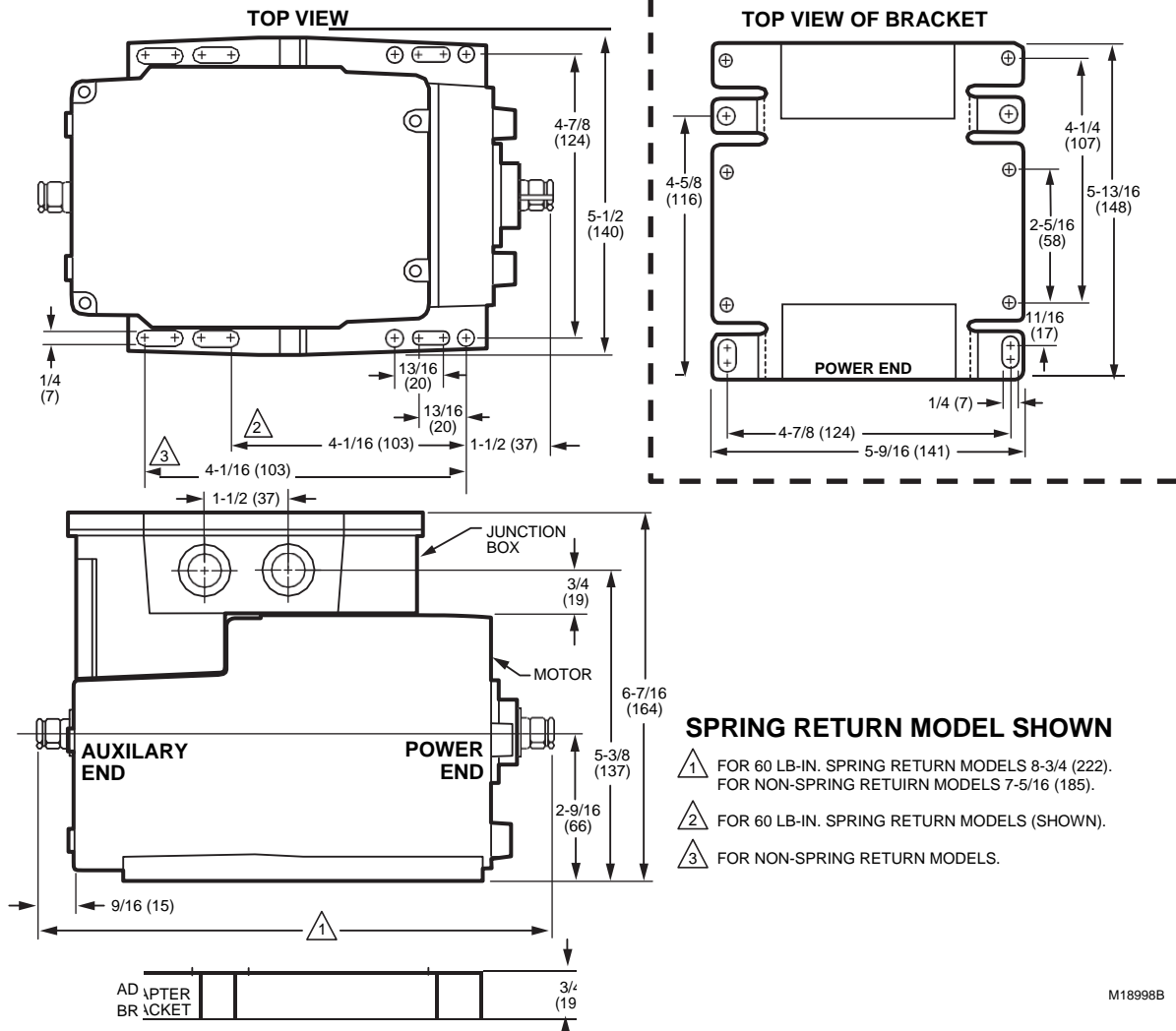

**Fig. 1. Series 61 and 62 Modutrol IV Motor mounting dimensions in inches (mm).**



SERIES 61 AND SERIES 62 MODUTROL IV™ MOTORS

Table 5. Series 61 and 62 Modutrol IV Motor Timing and Torque Ratings.

Table with 6 columns: Nominal Timing (90° Stroke, 160° Stroke), Normal Running Torque (Spring Return, Non-Spring Return), Breakaway Torque (Spring Return, Non-Spring Return). Rows include timing values like 15, 30, 60, 120 seconds and torque values in lb-in. and N·m.

a Timings apply to all TRADELINE models. Some OEM models are available with non-standard timing/torque.

b Torque ratings for dual-ended shaft motors are the sum of the shaft torques (power-end torque plus auxiliary-end torque).

c Breakaway torque is the maximum torque available to overcome occasional large loads such as a seized damper or valve.

NOTE: Torque designation corresponds to torque rating at standard timing (nominally 60 seconds for 160° and 30 seconds for 90° except for 300 lb-in. motors that have timings of 2 or 4 minutes).

IMPORTANT

Never use motor continuously at the Breakaway Torque rating.

Feedback Potentiometer (Series 62 Models Only):

TRADELINE Models (Can be shunted for slaving a Series 90 Motor).

Approvals:

Underwriters Laboratories Inc. Listed: File No. E4436, Guide No. XAPX.

Canadian Standards Association Certified: General Listed File No. LR1620, Guide No. 400-E.

U.S. Patents: pending

Accessories:

220736A Internal Auxiliary Switch Kit; one switch, can be field-installed.

220736B Internal Auxiliary Switch Kit; two switches, can be field-installed.

220738A Adapter Bracket raises motor shaft height by 3/4 inch (19 mm) to match that of previous Modutrol Motor models.

220741A Screw Terminal Adapter converts the standard quick-connect terminals to screw terminals.

221455A Infinitely Adjustable Crank Arm, can rotate through downward position and clear motor base without requiring an adapter bracket.

220738A Adapter Bracket for Modutrol IV Motor to match shaft height of Modutrol III Motor

4074ERU Weatherproofing Kit provides NEMA 3 rating for Modutrol IV Motors mounted in position other than upright.

50017460-001 Internal Transformer; 24/120/230 Vac 50/60 Hz primary, 24 Vac secondary, quick connect terminals.

50017460-003 Internal Transformer; 120 Vac 50/60 Hz primary, 24 Vac secondary, quick connect terminals.

7617ADW Crank Arm, can rotate through downward position and clear motor base without requiring an adapter bracket.

Q100 Linkage connects Modutrol Motor to V51 Butterfly Valve. Requires the 220738A Adapter Bracket.

Q181 Auxiliary Potentiometer for sequence or unison control of 1 to 4 additional modulating (Series 90) motors.

Q5001 Bracket and Linkage Assembly connects Modutrol IV Motor to water or steam valve.

Q605 Damper Linkage connects motor to damper. Includes motor crank arm.

Q607 External Auxiliary Switch controls auxiliary equipment as a function of motor position.

ES650-117 Explosion-Proof Housing encloses motor for use in explosive atmospheres. Not for use with Q5001 (or any other valve linkages). Order separately from Nelson Enclosures. To order, contact:

EGS Enclosures in Houston, TX

Karen Barfield 281-774-3763

Karen.Barfield@egseg.com

http://appleonelec.com

Part number ES-650-117

You need to order a 7617DM coupling assembly from Honeywell to use with the cover.

INSTALLATION

When Installing this Product...

- 1. Read these instructions carefully. Failure to follow them could damage the product or cause a hazardous condition.
2. Check the ratings given in the instructions and on the product to make sure the product is suitable for your application.
3. Installer must be a trained, experienced service technician.
4. After installation is complete, check out product operation as provided in these instructions.



CAUTION

Electrical Shock or Equipment Damage Hazard. Can shock individuals or short equipment circuitry.

Disconnect all power supplies before installation. Motors with auxiliary switches can have more than one disconnect.



CAUTION

Equipment Damage Hazard. Can damage the motor beyond repair.

Never turn the motor shaft by hand or with a wrench. Forcibly turning the motor shaft damages the gear train and stroke limit contacts.



**IMPORTANT**

Always conduct a thorough checkout when installation is complete.

**Location**

Allow enough clearance for accessory installation and motor servicing when selecting a location (see Fig. 1). If located outdoors, use liquid-tight conduit connectors with the junction box to provide NEMA 3 weather protection. If mounted outdoors in a position other than upright, install a 4074ERU Weatherproofing Kit and liquid-tight connectors to provide NEMA 3 protection.



**CAUTION**

**Motor Damage Hazard.**

**Deteriorating vapors and acid fumes can damage metal parts.**

Install motor in areas free of acid fumes and other deteriorating vapors.

In excessive salt environments, mounting base and screws should be zinc or cadmium plated, not stainless steel or brass. Use the 220738A Adapter Bracket for mounting on these surfaces.

**Mounting**

Use the following guidelines for proper motor mounting:

- Always install motors with the crankshaft horizontal.
- Mounting flanges extending from motor housing base are drilled for 1/4 inch (6.4 mm) machine screws or bolts.
- Non-Spring Return Motors are shipped from the factory in the closed position (at the limit of counterclockwise rotation, as viewed from the power end of the motor).
- Spring Return Motors are shipped from the factory in their normal position.
- Normally closed models are shipped at the limit of counterclockwise rotation, as viewed from the power end of the motor.

NOTE: Refer to Fig. 2 for graphical representation of fully-open and fully-closed positions.

**SERIES 61 AND SERIES 62 MODUTROL IV™ MOTORS**

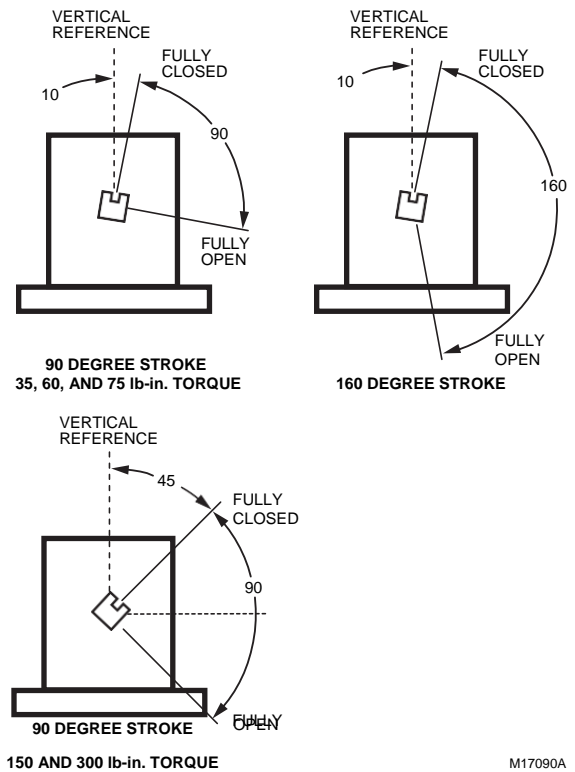

**Fig. 2. Motor shaft positions at stroke limits (viewed from power end of motor).**

**Adapter Bracket**

The 220738A Adapter Bracket, positioned between the motor and the equipment, raises motor shaft height by 0.75 in. (19 mm) to match that of previous Modutrol Motor models.

The following applications require this bracket:

- Q607 External Auxiliary Switch.
- Damper linkage applications require added clearance to allow:
  - Crank arm rotation through the downward position.
  - Sufficient damper linkage to reach the motor shaft.
- All valve linkages except the Q5001.

NOTE: When the bracket is not used in a replacement application, the damper linkage requires adjustment for the new shaft position.

To mount the motor with the bracket:

1. Mount the bracket to the equipment with existing or standard bolts.
2. Using the provided bolts, mount the motor to the bracket threaded holes. See Fig. 3.

For valve linkage applications (other than the Q5001):

1. Mount the bracket to the linkage.
2. Position the motor on the bracket to align the motor shaft with the linkage.
3. Attach the motor to the bracket with the four bolts provided. See Fig. 4.



SERIES 61 AND SERIES 62 MODUTROL IV™ MOTORS

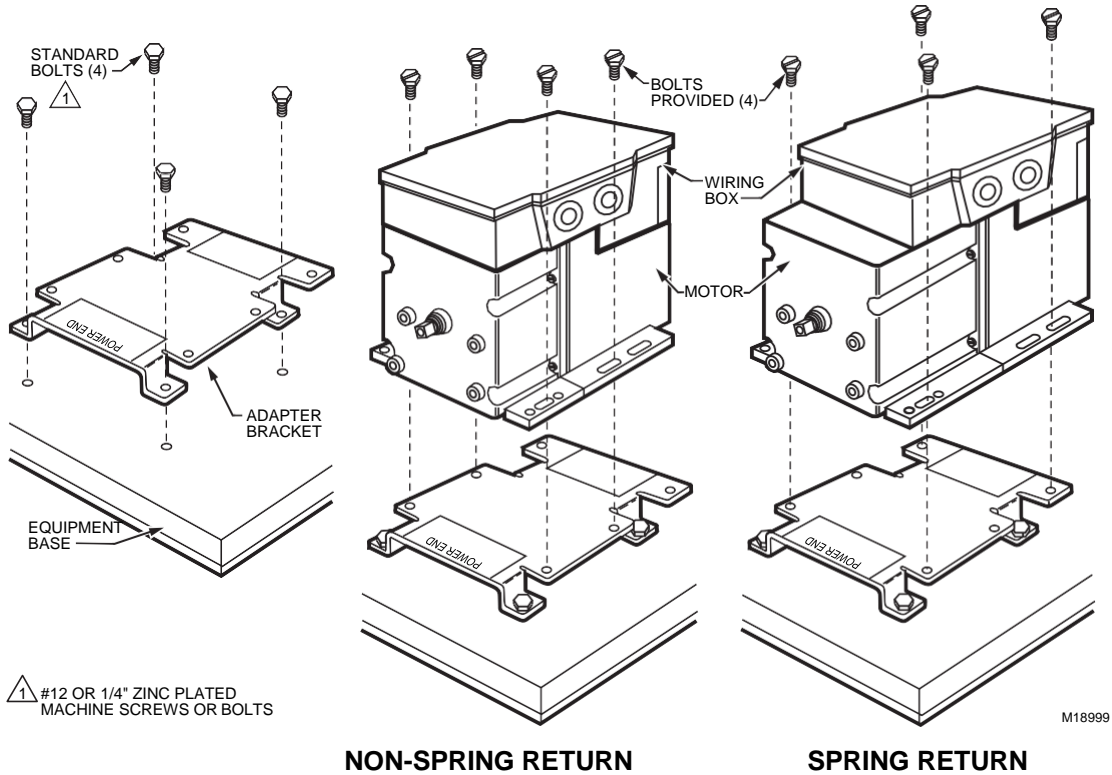

Fig. 3. Mounting the motor with an adapter bracket.

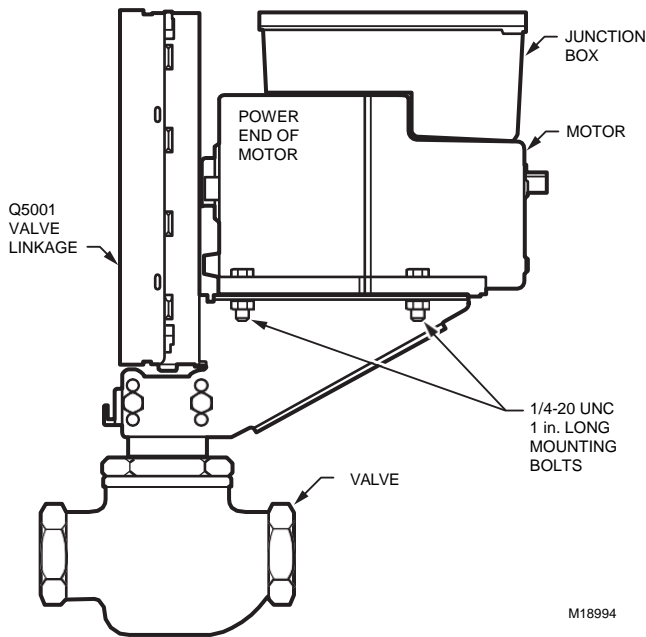

Fig. 4. Mounting the motor on a Q5001 Valve Linkage.

### Damper Linkages

The motor does not include a crank arm. Order the crank arm separately (see Accessories in the Specifications section). For detailed instructions on the assembly of specific linkages, refer to the Installation Instructions packed with the linkage.



### CAUTION

**Equipment Damage Hazard. Stalling a motor can damage the drive shaft.**

Ensure installation of motors and linkages allows the motor to drive through full stroke without obstruction.

### Valve Linkages

The Q100 Linkage requires a 220738A Adapter Bracket for all valve applications. Applications with the Q5001 Valve Linkage do not require the 220738A Adapter Bracket (see Fig. 4).

### Junction Box

When used with liquid-tight conduit connectors, the junction box provides NEMA 3 weather protection for the motor. The junction box, standard with replacement motors, encloses the terminals and provides knockouts for wiring conduits. Housing an internal transformer or internal auxiliary switches requires using a junction box.



SERIES 61 AND SERIES 62 MODUTROL IV™ MOTORS

Wiring



CAUTION

Electrical Shock or Equipment Damage Hazard. Can shock individuals or short equipment circuitry. Disconnect all power supplies before installation. Motors with auxiliary switches can have more than one disconnect.

IMPORTANT

All wiring must agree with applicable codes, ordinances and regulations.

- 1. Ensure that the voltage and frequency stamped on the motor correspond with the power supply characteristics.
2. When connecting several motors in parallel, ensure that the power supply VA rating is large enough to provide power to all motors used without overloading.
3. Fig. 5 shows that motor terminals are quick-connects located on top of the printed circuit board.
4. To access the wiring compartment: a. Remove the four screws from the junction box top. b. Lift off the cover.
5. Refer to Fig. 6 for typical wiring, and Fig. 11 for internal auxiliary switch connections.

NOTE: Reverse motor rotation by switching wires at either the motor or panel. Reverse rotation on Series 61 models by reversing wires at terminals W and B. Reverse rotation on Series 62 models by reversing wires at terminals 1 and 2 (to correct motor rotation) and reverse wires at terminals Y and G (to maintain a feedback signal that corresponds with shaft rotation),

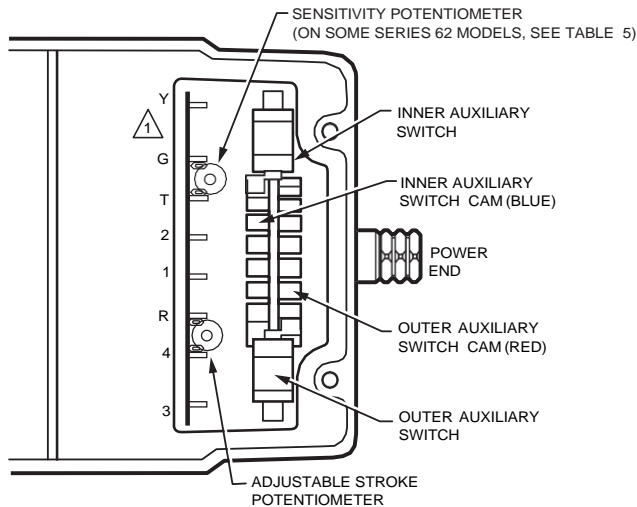

1 SERIES 62 TERMINAL DESIGNATIONS SHOWN.

NOTE: NOT ALL FEATURES AVAILABLE ON ALL MODELS. M13600B

Fig. 5. Terminals and adjustments.

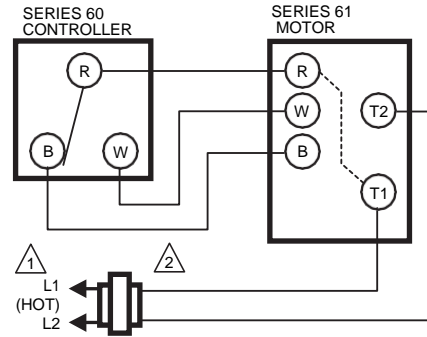

1 POWER SUPPLY. PROVIDE DISCONNECT MEANS AND OVERLOAD PROTECTION AS REQUIRED.

2 TRANSFORMER MAY BE INTERNAL OR EXTERNAL TO MOTOR. M17095A

Fig. 6. Series 61 motor wiring.

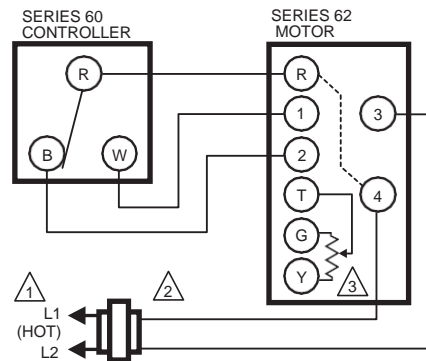

1 POWER SUPPLY. PROVIDE DISCONNECT MEANS AND OVERLOAD PROTECTION AS REQUIRED.

2 TRANSFORMER MAY BE INTERNAL OR EXTERNAL TO MOTOR.

3 FEEDBACK POTENTIOMETER. M17096

Fig. 7. Series 62 motor wiring.



CAUTION

Ensure that L1(hot) on the transformer matches 4 (internal hot) on the motor and L2 matches 3 (internal ground) on the motor.



SERIES 61 AND SERIES 62 MODUTROL IV™ MOTORS

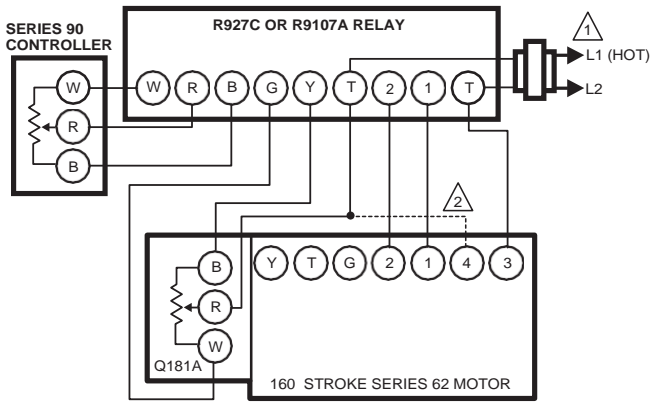

⚠ POWER SUPPLY. PROVIDE DISCONNECT MEANS AND OVERLOAD PROTECTION AS REQUIRED.

⚠ CONNECTION REQUIRED ONLY FOR SPRING RETURN MOTORS. M17098A

Fig. 8. Connections to R927C or R9107A Relay.

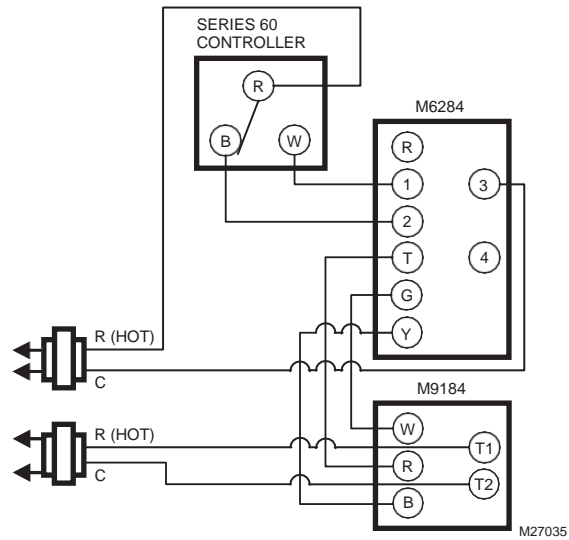
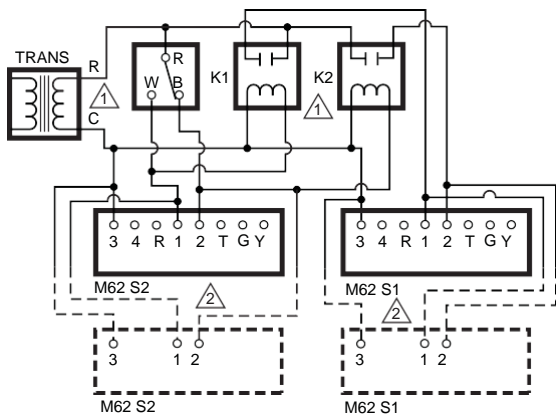

Fig. 10. Series 60 and Series 90 in Slaving Application

NOTE: Vibration does not affect Modutrol IV Motor performance (as it did in earlier Modutrol Motors). When replacing a motor that was connected to an R927C or R9107A Relay, Honeywell recommends performing a retrofit to remove the relay and the old motor. Replace both with one Series 90 Modutrol IV motor (that is, do not replace the relay).

WIRING DIAGRAM M62XX SERIES 1 AND SERIES 2 PARALLEL APPLICATION



⚠ SIZE RELAYS AND TRANSFORMER PER SYSTEM REQUIREMENTS.

⚠ ADDITIONAL SERIES 2 OR SERIES 1 MOTORS CAN BE ADDED IN PARALLEL. DO NOT MIX SERIES 1 AND SERIES 2 IN THE SAME LINE. ONLY WIRE SERIES 1 WITH SERIES 1 AND SERIES 2 WITH SERIES 2 IN PARALLEL. M27044

Fig. 9. Series 1 and Series 2 Parallel Application

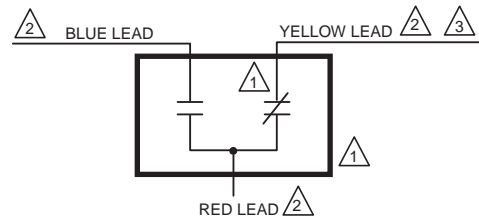

⚠ USE NEC CLASS 1 WIRING UNLESS POWER SUPPLY MEETS CLASS 2 REQUIREMENTS. TAPE UNUSED LEADS. ENSURE THE CURRENT DRAW OF THE EXTERNAL CIRCUIT IS LESS THAN SWITCH CONTACT RATING.

⚠ ON TWO-SWITCH MOTORS, SECOND SWITCH HAS BLACK LEADS WITH BLUE, YELLOW, AND RED TRACERS.

⚠ SOME AUXILIARY SWITCH ASSEMBLIES INCLUDE ONLY RED AND YELLOW LEADS. SOME OTHERS DO NOT INCLUDE THE YELLOW LEAD. M17099

Fig. 11. Auxiliary switch schematic.





## SETTINGS AND ADJUSTMENTS

### Before Setting Stroke

1. Remove the top cover from the motor.
2. Disconnect the controller from the motor.
3. For models with an internal transformer (line voltage motors), ensure that power (and nothing else) remains connected to the motor.

#### IMPORTANT

Detach linkage from motor before adjusting stroke.

### Adjustable Stroke

#### Series 61 Adjustable Stroke

When viewing from the power end of the motor, the stroke potentiometer is to the far left. To set the stroke to 160° (maximum position) turn the potentiometer fully clockwise ↻, using a 1/8 in. straight-blade screwdriver. To set the stroke at 90° (minimum position) turn the potentiometer fully counter-clockwise ↺. Setting the potentiometer anywhere between fully clockwise and fully counter-clockwise will set the stroke between 160° and 90°.

#### Series 62 Adjustable Stroke

When viewing from the power end of the motor, the stroke potentiometer is to the far left. The sensitivity potentiometer is to the far right. To set the stroke to 160° (maximum position) turn both potentiometers fully clockwise ↻, using a 1/8 inch straight-blade screwdriver. To set the stroke at 90° (minimum position) turn both potentiometers fully counter-clockwise ↺. Setting the potentiometer anywhere between fully clockwise and fully counter-clockwise will set the stroke between 160° and 90°.



### CAUTION

**Careless Installation Hazard.**  
Use of excessive force while adjusting cams damages the motor.

To avoid damaging motor end switches, set cams by moving only the screwdriver top.



### CAUTION

**Equipment Damage Hazard.**  
Can damage the motor beyond repair.

Never turn the motor shaft by hand or with a wrench. Forcibly turning the motor shaft damages the gear train and stroke limit contacts.

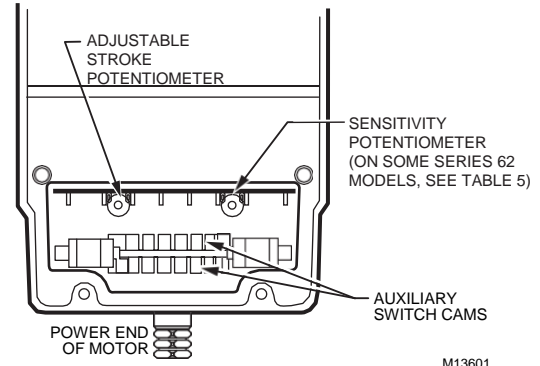

Fig. 12. Stroke adjustments setup.

### Feedback Potentiometer Configuration (Series 62 TRADELINE® Motors Only)

Select and install a shunt resistors to obtain the appropriate feedback characteristic for your application. See the Specifications section for details on feedback resistance without a shunt resistor.

- Linear feedback provides linear indication of shaft position with no shunt resistor.
- Slaving a Series 90 Motor requires full-stroke feedback resistance of 142 ohms. Select and attach the proper shunt resistor across terminals Y and G (see Table 2 and Fig. 13).

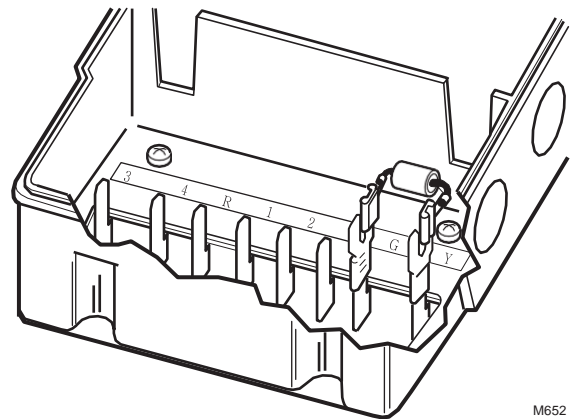

Fig. 13. Attaching a shunt resistor to TRADELINE motors.

### Auxiliary Switches

Adjustable cams actuate the auxiliary switches. These cams can be set to actuate the switches at any angle within the motor stroke. Select switch differential of 1° or 10°.

Motors with factory-added auxiliary switches are shipped in the closed position (fully counterclockwise, as viewed from the power end). Auxiliary cam default actuates the switches 30° from fully open with a 1° differential. With the motor in the closed (fully counterclockwise) position, the auxiliary switch breaks contacts R-B. See Fig. 11 (or the auxiliary switch Installation Instructions) for auxiliary switch wiring.

NOTE: Series 2 Motors are shipped with auxiliary switch cams that permit acceptance of 220736A,B Internal Auxiliary Switch Kits. Refer to Form no. 63-2228 for 220736A,B Installation Instructions.



SERIES 61 AND SERIES 62 MODUTROL IV™ MOTORS

Auxiliary Switch Adjustment

IMPORTANT

When adjusting the auxiliary switch cams use the following procedure:

- 1. Insert 1/8 in. screwdriver blade into a slot on cam and move the screwdriver top as far as possible in the required direction. See Fig. 14.
2. Repeat step 1 in successive cam slots until the cam is in the required position.

Use the following procedure to obtain the desired auxiliary switch settings:

- 1. Remove the top cover from the motor to gain access to the motor terminals and auxiliary cams.
2. Disconnect the controller from the motor.
3. Drive the motor to the position where the auxiliary equipment is to be switched as follows:
a. For Non-Spring Return models without a transformer, connect 24 Vac to terminals 2 and 3 to drive motor open (clockwise as viewed from the power end), or to terminals 1 and 3 to drive motor closed (counterclockwise).
b. For Non-Spring Return models with a transformer, jumper across terminals R and 2 to drive motor open (clockwise as viewed from the power end), or across terminals R and 1 to drive motor closed (counterclockwise).
c. For Spring Return models, connect a jumper across terminals 2 and 4 to drive the motor open, or across terminals 1 and 4 to drive the motor closed.

- 4. Once motor reaches correct position, disconnect the jumper.
5. For a switch differential of 1°, check continuity of auxiliary switch contacts R-B and rotate the cam as follows:
a. If the contacts are open, rotate the cam clockwise until the R-B contacts close.
b. If the contacts are closed, rotate the cam counterclockwise until the R-B contacts open.
6. For a switch differential of 10°:
a. For Spring Return models, rotate the cam approximately 180° so the slow-rise portion of the cam actuates the switch. Then check continuity of the auxiliary switch contacts R-B.
b. For Non-Spring Return models, check continuity of the auxiliary switch contacts R-B.
7. Rotate the cam as follows:
a. If the contacts are open, rotate the cam counterclockwise until the R-B contacts close.
b. If the contacts are closed, rotate the cam clockwise until the R-B contacts open.
8. Check for the proper differential and switching of the auxiliary equipment by driving the motor through the full stroke in both directions.
9. Disconnect the jumper, reconnect the controller, and replace the top cover on the motor.

NOTE: Changing the differential from 1° to 10° reverses the switching action. For example, with a 10° differential, switch contacts R-B make and R-W break on a counterclockwise (closed) rotation. With a 1° differential, switch contacts R-W make and R-B break on a counterclockwise (closed) rotation.

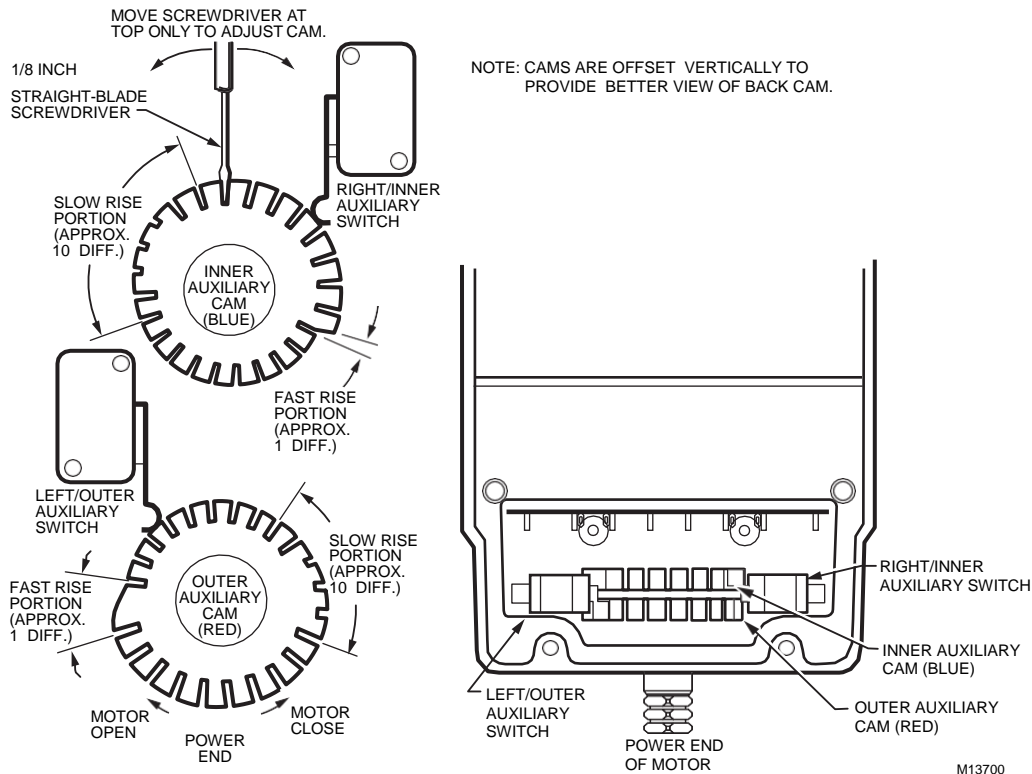

Fig. 14. Auxiliary switch adjustment.



## OPERATION

Use Series 61 and 62 Modutrol IV Motors for standard Series 60 operation (drive open, hold, drive closed). Series 62 motors can also be used with the feedback potentiometer as an input to the controller.

See Table 6 for details on motor response to controller signals.

NOTE: Reverse the wires at either the motor or controller.

To reverse the rotation direction of a non-spring return motor:

- Reverse the wires at terminals W and B.

**Table 6. Modutrol IV Motor Operation.**

Motor Type	Terminal Connection		Resulting Action
	Series 61	Series 62	
Non-Spring Return or Spring Return	R-W	4-1	ccw (closed)
	R-B	4-2	cw (open)
Non-Spring Return	None	None	stops (none)
Spring Return	-	None	spring return (closed)

## CHECKOUT

After the installation and linkage adjustment, check the entire motor and control hookup. Proper checkout ensures that:

- The motor operates the load (damper or valve) properly.
  - The motor responds properly to the controller as the input varies. See Table 6.
  - The auxiliary switch, if used, operates at the desired point of motor rotation.
1. Inspect motor, linkage, and valve or damper to ensure all mechanical connections are correct and secure.

NOTE: In damper installations, the pushrod should not extend more than a few inches past the ball joints.

2. Ensure that there is adequate clearance for the linkage throughout the entire motor stroke without binding or striking other objects.
3. Drive the motor fully open and fully closed. See Table 6.

NOTE: Refer to controller or system instructions for additional checkout procedures.

4. For spring return motors, ensure that the valve or damper returns to its normal position when power is interrupted.
5. Return controller to the desired setting before leaving the job.

## REPLACEMENT

### Damper Application

1. Turn off power and remove wiring from the old motor.
2. Remove the crank arm from the shaft of the old motor and remove the old motor.
3. Determine mounting bracket necessity. If the linkage can reach the new motor shaft position and the crank arm has clearance for the necessary rotation, the bracket is not required. Use the 220738A Adapter Bracket or the 221455A Crank Arm if the crank arm must rotate through the bottom plane of the motor.
  - a. If no bracket is required, mount the new motor directly to the equipment and refer to the Installation, Settings and Adjustments, and the Operation and Checkout sections.
  - b. If the bracket is required, refer to the Adapter Bracket section and Fig. 3 in addition to the Installation, Settings and Adjustments, and the Operation and Checkout sections.
4. Use No. 12 or 1/4 inch machine screws or bolts to mount the new motor.
5. Mount damper crank arm and linkage to the new motor shaft.
6. Use the Checkout procedures to test the crank arm and linkage adjustment.

### Valve Application

When replacing a motor in a valve application, the linkage type determines the necessity for the 220738A Adapter Bracket. With Q100, Q601 or Q618 Linkages, it is necessary to use the 220738A to raise the motor shaft to the appropriate height. Valve applications with a Q5001 Linkage do not require the 220738A Adapter Bracket. To operate Honeywell V5011 Two-way or V5013 Three-way Valves through full stroke, use a 160° stroke motor.



บริษัท เอดีดี เฟอร์เนส จำกัด

ADD FURNACE CO.,LTD.

44 ซอยบรมราชชนนี 70 ถนนบรมราชชนนี แขวงศาลาธรรมสพน์ เขตทวีวัฒนา กรุงเทพฯ 10170

โทร: 02-888-3472 โทร: ออกแบบ:08-08-170-170 แฟกซ์: 02-888-3258

<https://www.add-furnace.com> E-mail: [sales@add-furnace.com](mailto:sales@add-furnace.com)

SERIES 61 AND SERIES 62 MODUTROL IV™ MOTORS

By using this Honeywell literature, you agree that Honeywell will have no liability for any damages arising out of your use or modification to, the literature. You will defend and indemnify Honeywell, its affiliates and subsidiaries, from and against any liability, cost, or damages, including attorneys' fees, arising out of, or resulting from, any modification to the literature by you.

#### Automation and Control Solutions

Honeywell International Inc.  
1985 Douglas Drive North  
Golden Valley, MN 55422  
[customer.honeywell.com](http://customer.honeywell.com)

Honeywell Limited-Honeywell Limitée  
35 Dynamic Drive  
Toronto, Ontario M1V 4Z9

© U.S. Registered Trademark  
© 2008 Honeywell International Inc.  
63-2629—05 M.S. Rev. 07-08



Printed in U.S.A. on recycled  
paper containing at least 10%  
post-consumer paper fibers.

# Honeywell