

# Liquid Automatic Changeover Devices

# Electrical Heating Type Vaporisers



LAX-20C

### External Dimensions

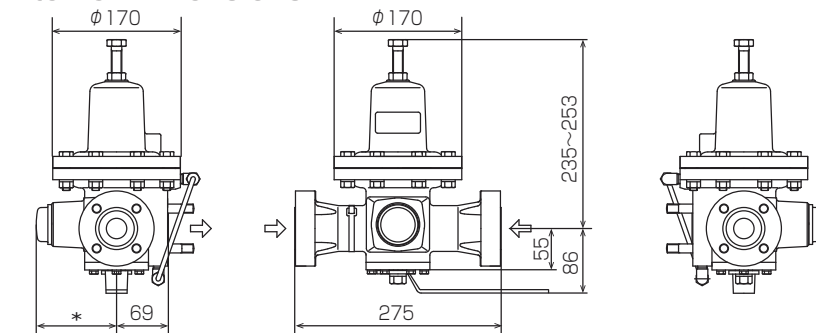

### Accessories

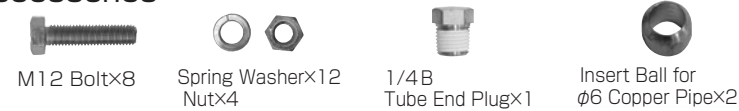

### Specifications

Gas Type	LPG(Liquid LPG)												
Maximum Flow Rate	300kg/h												
Changeover Pressure	0.05~0.15MPa												
Changeover Operating Pressure Allowance	±0.01MPa												
Required Inlet Pressure (Minimum Pressure at Reserve Side)	(Changeover Pressure + ΔP) ~ 1.56MPa The values for ΔP are shown below;												
	<table border="1"> <tr> <td>Q; Flow Rate(kg/h)</td> <td>100</td> <td>150</td> <td>200</td> <td>250</td> <td>300</td> </tr> <tr> <td>ΔP(MPa)</td> <td>0.03</td> <td>0.07</td> <td>0.11</td> <td>0.14</td> <td>0.18</td> </tr> </table>	Q; Flow Rate(kg/h)	100	150	200	250	300	ΔP(MPa)	0.03	0.07	0.11	0.14	0.18
Q; Flow Rate(kg/h)	100	150	200	250	300								
ΔP(MPa)	0.03	0.07	0.11	0.14	0.18								
Connection	Equivalent to JIS20K20A Flange												



LAX-20C-R

With Signal Transmitting Function

### External Dimensions

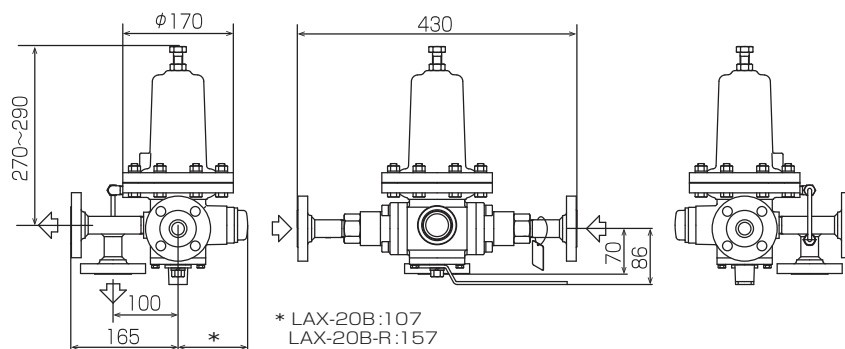

### Accessories



### Specifications

Gas Type	LPG(Liquid LPG)												
Maximum Flow Rate	300kg/h												
Changeover Pressure	0.05~0.15MPa												
Changeover Operating Pressure Allowance	±0.01MPa												
Required Inlet Pressure (Minimum Pressure at Reserve Side)	(Changeover Pressure + ΔP) ~ 1.56MPa The values for ΔP are shown below;												
	<table border="1"> <tr> <td>Q; Flow Rate(kg/h)</td> <td>100</td> <td>150</td> <td>200</td> <td>250</td> <td>300</td> </tr> <tr> <td>ΔP(MPa)</td> <td>0.03</td> <td>0.07</td> <td>0.11</td> <td>0.14</td> <td>0.18</td> </tr> </table>	Q; Flow Rate(kg/h)	100	150	200	250	300	ΔP(MPa)	0.03	0.07	0.11	0.14	0.18
Q; Flow Rate(kg/h)	100	150	200	250	300								
ΔP(MPa)	0.03	0.07	0.11	0.14	0.18								
Connection	JIS20K20A Flange												



LAX-20B



LAX-20B-R

With Signal Transmitting Function



f RIZER Type S

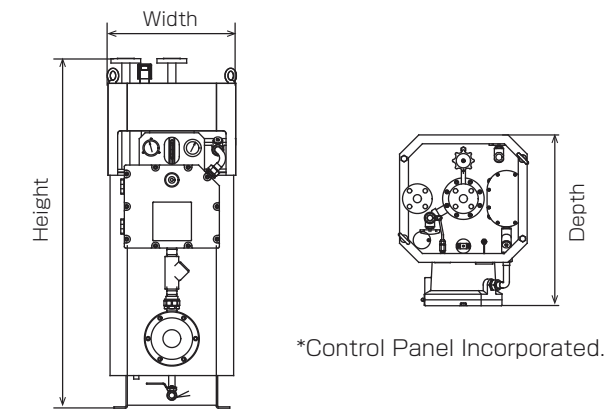

### Specifications

Items	Model	S-50	S-100	S-150	S-200	S-300
Vaporisation Capacity (LPG)		50kg/h	100kg/h	150kg/h	200kg/h	300kg/h
Heat Source	Heater Capacity	7.5kW	15kW	22.5kW	30kW	45kW
	Rated Voltage	220/380/440V 3-Phase				
Hot Water Control Temperature		60~75°C (70°C Set Point)				
Hot Water Superheat Prevention		80°C				
Liquid Carryover Protection		By means of Float Valve				
Working Pressure for Safety Valve		1.80MPa				
Inlet Pressure		0.10~1.56MPa				
Connection	Liquid Inlet Flange	Equivalent to JIS 20K20A				
	Gas Outlet Flange	Equivalent to JIS 20K20A		Equivalent to JIS 20K25A		
External Dimensions	Width	420mm	420mm	480mm	580mm	580mm
	Depth	570mm	570mm	630mm	740mm	740mm
	Height	1115mm	1183mm	1253mm	1215mm	1315mm

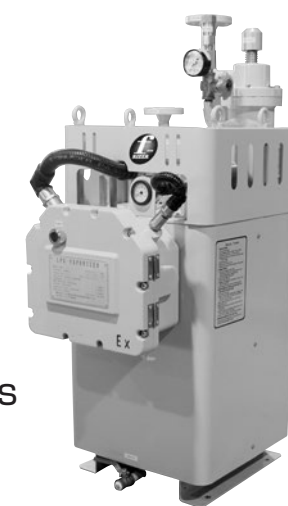

f RIZER ITOS

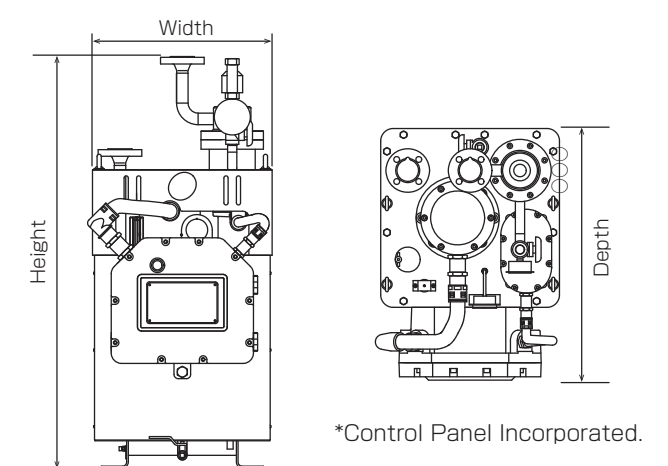

### Specifications

Items	Model	ITOS-30	ITOS-50	ITOS-100	ITOS-150	ITOS-200	ITOS-300
Vaporisation Capacity (LPG)		30kg/h	50kg/h	100kg/h	150kg/h	200kg/h	300kg/h
Heat Source	Heater Capacity	4.5kW	7.5kW	15kW	22.5kW	30kW	45kW
	Rated Voltage	220V Single-Phase		220/380/440V 3-Phase			
Hot Water Control Temperature		60~80°C (75°C Set Point)					
Hot Water Superheat Prevention		85°C					
Liquid Carryover Protection		By means of Float Valve					
Working Pressure for Safety Valve		1.75MPa					
Inlet Pressure		0.10~1.60MPa					
Connection	Liquid Inlet Flange	DN20(PN25)			DN25(PN25)		
	Gas Outlet Flange	DN20(PN25)		DN25(PN25)			