



บริษัท เอดีดี เฟอร์เนส จำกัด

ADD FURNACE CO.,LTD.

44 ซอยบรมราชชนนี 70 ถนนบรมราชชนนี แขวงศาลาธรรมสพน์ เขตทวีวัฒนา กรุงเทพฯ 10170

โทร: 02-888-3472 โทร: ออกแบบ:08-08-170-170 แฟกซ์: 02-888-3258

<https://www.add-furnace.com> E-mail: sales@add-furnace.com

Honeywell

**krom
schroder**

Burners for gas BIO, BIOA, BIOW, ZIO, ZIOW

TECHNICAL INFORMATION

- To be used in combination with a burner block made from refractory concrete
- Different flame shapes can be achieved by using burner blocks with different geometries
- Large capacity range up to 1000 kW (3782 × 103 BTU/h)
- Length increments enable individual adjustment to the wall thickness of the system
- Air preheating to 600°C (1112°F)





Contents

Contents2	5.3 Burner size	17
Contents2	5.4 Burner head selection.....	18
1 Application4	5.4.1 Use.....	18
1.1 Application examples.....	7	5.4.2 Gas type.....	19
1.1.1 Modulating control with pneumatic ratio control system ..	7	5.4.3 Variant	19
1.1.2 Modulating control with pneumatic ratio control system and torch.....	7	5.5 Field of application	20
1.1.3 Cascade control for higher turndown	8	5.5.1 Burners with burner block	21
1.1.4 ON/OFF cyclic control.....	8	5.5.2 Burners with burner attachment tube	23
1.1.5 ON/OFF cyclic control with a defined pilot rate.....	9	5.6 High temperature version	25
1.1.6 Staged control with pneumatic ratio control system and LOW/HIGH cyclic control.....	9	5.7 Selection table.....	26
2 Certification	10	5.7.1 Burner type.....	26
3 Mechanical construction	11	5.7.2 Type code.....	27
3.1 Burner body (furnace flange).....	11	6 Project planning information	28
3.2 Burner insert.....	12	6.1 Installation	28
3.2.1 Burners with integrated torch.....	13	6.2 Flat flame burner spacing	28
3.2.2 Heat-resistant, with purged electrodes	13	6.3 Ignition.....	28
3.2.3 High temperature version.....	13	6.3.1 Ignition with reduced capacity	28
3.3 Burner tube.....	14	6.3.2 Ignition with defined pilot rate.....	28
3.3.1 Burner tube in burner block	14	6.3.3 Ignition without defined pilot rate.....	28
3.3.2 Burner tube with attachment tube.....	14	6.4 Recommended ignition transformer	29
4 Function	15	6.5 Non-return gas valve.....	29
4.1 Burners with spark electrode.....	15	6.6 Flame control	29
4.2 Burners with integrated torch	16	6.6.1 Burners with UV sensor	29
5 Selection	17	6.6.2 Burners with torch	29
5.1 Capacity data	17	6.7 Operation with changing gas types.....	29
5.2 Burner type.....	17	6.8 Hot air operating mode.....	30
		6.9 Extended burner head identifier	30
		6.10 Contaminated fuel gases.....	30



บริษัท เอดีดี เฟอร์เนส จำกัด

ADD FURNACE CO.,LTD.

44 ซอยบรมราชชนนี 70 ถนนบรมราชชนนี แขวงศาลาธรรมสพน์ เขตทวีวัฒนา กรุงเทพฯ 10170

โทร: 02-888-3472 โทร: ออกแบบ:08-08-170-170 แฟกซ์: 02-888-3258

<https://www.add-furnace.com> E-mail: sales@add-furnace.com

6.11 Minimum low-fire rate.....	31	8.3.8 ZIO [inch]	47
6.12 Purge air/cooling air.....	31	8.3.9 ZIOW [mm].....	48
6.12.1 Electrodes with air connection	32	8.3.10 ZIOW [inch].....	49
6.13 Emissions	32	8.3.11 Torch BIO/BIOW.....	50
6.14 Gas line connection.....	33	8.3.12 Torch ZIO/ZIOW	51
6.15 Air line connection.....	33	8.3.13 Electrodes with air connection BIO/BIOW	52
6.16 Gaskets for higher connection pressures	33	8.3.14 Electrodes with air connection ZIO/ZIOW.....	53
6.17 Condition on delivery.....	33	9 Maintenance cycles	54
6.18 Intermittent operation.....	33	10 Legend	55
6.19 Build up of noise	34	10.1 Legend (mechanical)	55
6.20 Installation in a humid environment.....	34	For More Information	56
6.21 Heat guard	34		
7 Accessories	35		
7.1 Adapter set.....	35		
7.1.1 Integrated torch connections.....	35		
7.2 Ceramic paste	35		
7.3 UV sensor	35		
7.4 Gasket sets for reverse flow pressure	36		
8 Technical data	37		
8.1 REACH Regulation	37		
8.2 Burner block.....	38		
8.3 Dimensions.....	40		
8.3.1 BIO [mm]	40		
8.3.2 BIO [inch].....	41		
8.3.3 BIOA [mm]	42		
8.3.4 BIOA [inch].....	43		
8.3.5 BIOW [mm].....	44		
8.3.6 BIOW [inch]	45		
8.3.7 ZIO [mm].....	46		



บริษัท เอดีดี เฟอร์เนส จำกัด

ADD FURNACE CO.,LTD.

44 ซอยบรมราชชนนี 70 ถนนบรมราชชนนี แขวงศาลาธรรมสพน์ เขตทวีวัฒนา กรุงเทพฯ 10170

โทร: 02-888-3472 โทร: ออกแบบ:08-08-170-170 แฟกซ์: 02-888-3258

<https://www.add-furnace.com> E-mail: sales@add-furnace.com

Application

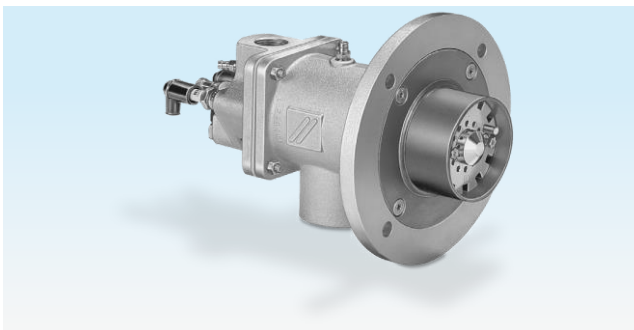

BIO

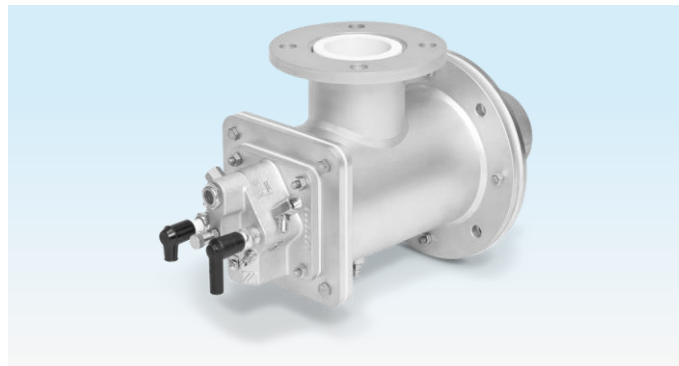

ZIO

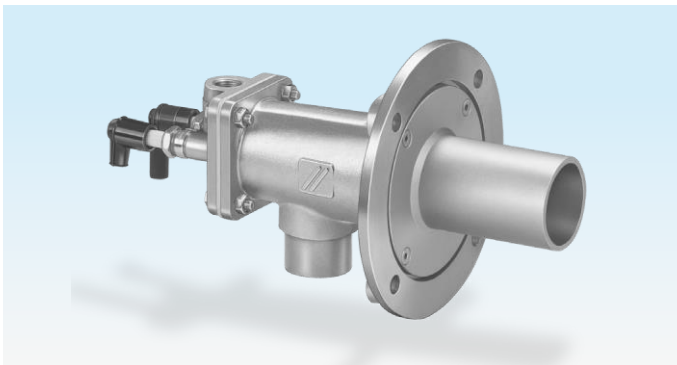

BIOA

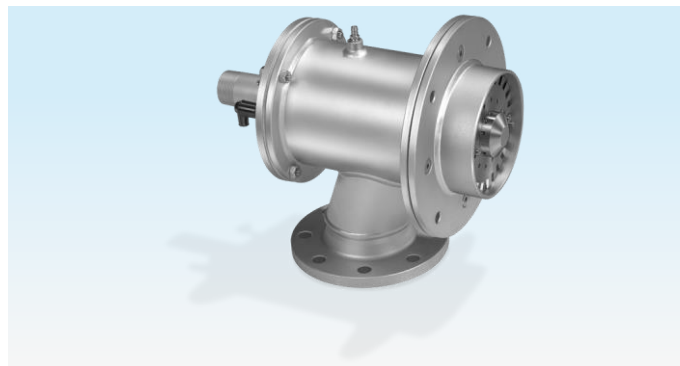

industries, in the precious, non-ferrous and light metal sectors, as well as in the plastics, fibre and paper industries. Other fields of application are thermal incineration installations, as well as dryers and hot air generators. The burners are used in combination with a burner block made from refractory concrete. Different flame shapes can be



บริษัท เอดีดี เฟอร์เนส จำกัด

ADD FURNACE CO.,LTD.

44 ซอยบรมราชชนนี 70 ถนนบรมราชชนนี แขวงศาลาธรรมสพน์ เขตทวีวัฒนา กรุงเทพฯ 10170

โทร: 02-888-3472 โทร: ออกแบบ:08-08-170-170 แฟกซ์: 02-888-3258

<https://www.add-furnace.com> E-mail: sales@add-furnace.com

achieved by using burner blocks with different geometries. The burner may be adapted to the system requirements using different burner lengths. A high temperature version of the burner is available for high temperature applications (e.g. forging furnaces). For low temperature applications (e.g. for radiant tube heating or hot air generation), the burners are equipped with a heat-resistant steel attachment tube.



Smelting and holding furnace



Bogie hearth furnace



Incineration installation for thermal regenerative flue air purification



Strip galvanizing plant



บริษัท เอดีดี เฟอร์เนส จำกัด

ADD FURNACE CO.,LTD.

44 ซอยบรมราชชนนี 70 ถนนบรมราชชนนี แขวงศาลาธรรมสพน์ เขตทวีวัฒนา กรุงเทพฯ 10170

โทร: 02-888-3472 โทร: ออกแบบ:08-08-170-170 แฟกซ์: 02-888-3258

<https://www.add-furnace.com> E-mail: sales@add-furnace.com

Application



Rotary table furnace



Aluminium tank furnace



Application

1 .1 Application examples

1.1.1 Modulating control with pneumatic ratio control system

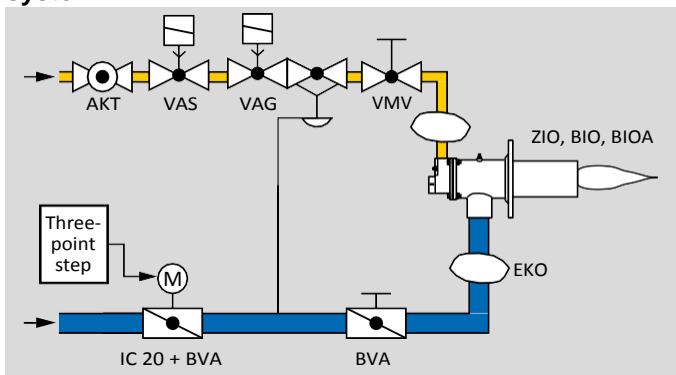

The burner capacity is controlled in modulating mode by adjusting the butterfly valve BVA. The impulse line on the air/ gas ratio control VAG ensures constant air and gas pressures. The ratio of the gas volume is kept constant. This type of control is used in melting furnaces in the aluminium industry or in regenerative incineration installations in the environment industry, for example.

1 .1 .2 Modulating control with pneumatic ratio control system and torch

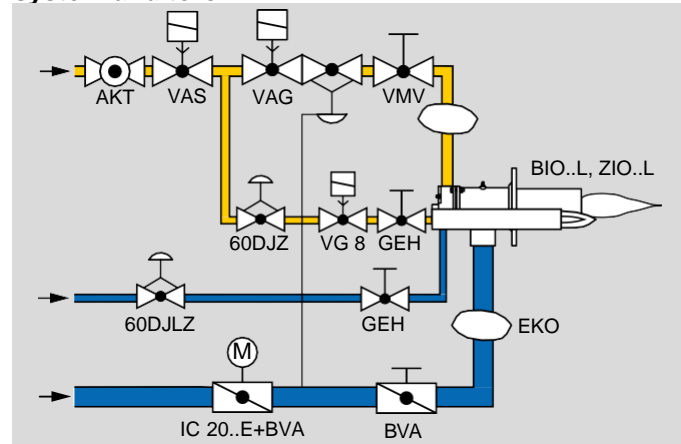

The burner's flexibility is increased thanks to a torch. This type of control is used in heat treatment furnaces in the iron and non-ferrous metal industries and in heating furnaces in the steel industry, for example.



บริษัท เอดีดี เฟอร์เนส จำกัด

ADD FURNACE CO.,LTD.

44 ซอยบรมราชชนนี 70 ถนนบรมราชชนนี แขวงศาลาธรรมสพน์ เขตทวีวัฒนา กรุงเทพฯ 10170

โทร: 02-888-3472 โทร: ออกแบบ:08-08-170-170 แฟกซ์: 02-888-3258

https://www.add-furnace.com E-mail: sales@add-furnace.com

1.1.3 Cascade control for higher turndown

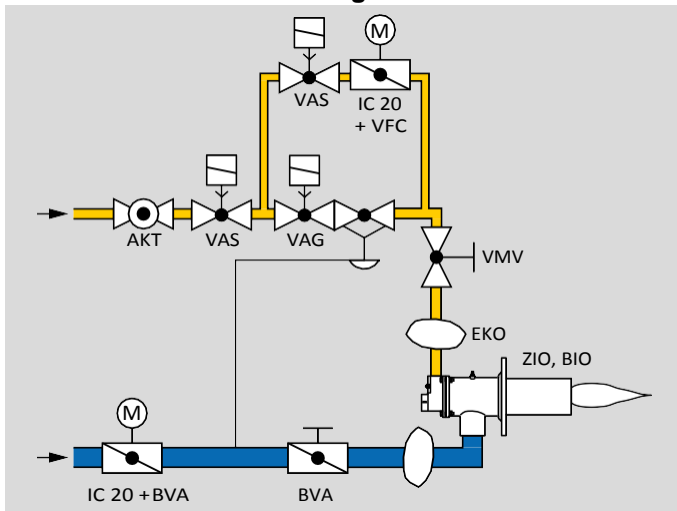

The burner is adjusted near-stoichiometrically to a low-fire rate of 10% using a pneumatic ratio control system. Smaller capacities can be adjusted with the IC 20 at a constant low-fire air flow rate by restricting the gas flow. With cascade control, turndown ratios of 1:45 can be achieved with excess air.

1.1.4 ON/OFF cyclic control

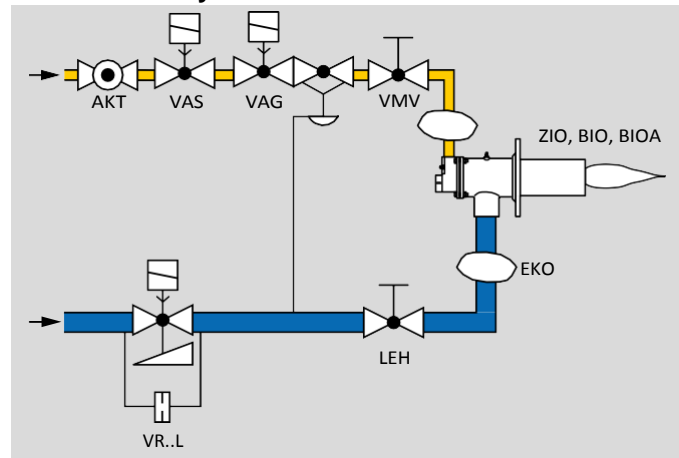

With ON/OFF cyclic control, the input into the process is controlled by means of a variable ratio of the operating time to the pause time.

The burner is ignited while the air valve is opening slowly. The pneumatic ratio control system controls the gas volume and ensures a constant mixture of gas and air in the burner. In accordance with EN 746-2, this type of control can only be used for burner capacities of up to 360 kW (1229 × 103BTU/h). Depending on the furnace temperature, there must be a certain air flow when the burner is switched off, see page 31 (Purge air/coolingair).



1.1.5 ON/OFF cyclic control with a defined pilot rate

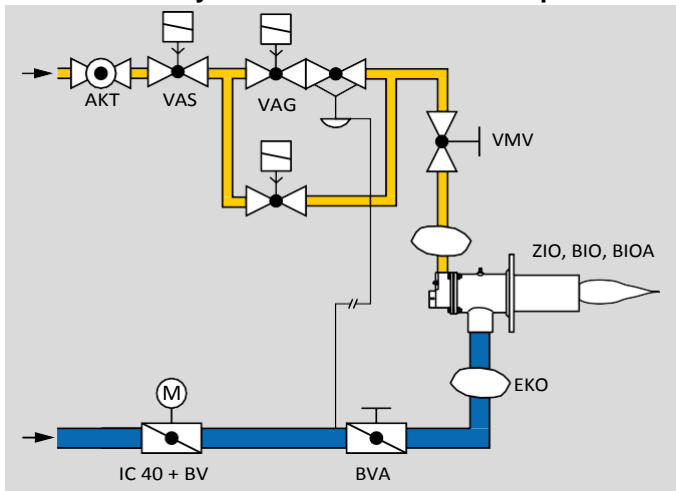

With this kind of cyclic control, the capacity supplied to the process is controlled by means of a variable ratio of the operating time to the pause time (ON/OFF).

Here, the burner is ignited at a defined pilot rate via a bypass valve (PILOT RATE/HIGH/OFF burner control). This burner system can thus be used regardless of the burner capacity. A 2-stage air control valve allows the volume of air infiltrating when the burners are switched off to be minimized. Alternatively, a single-stage air control valve with bypass for the pilot rate can be used if the volume of air infiltrating into the process is non-critical.

1.1.6 Staged control with pneumatic ratio control system and LOW/HIGH cyclic control

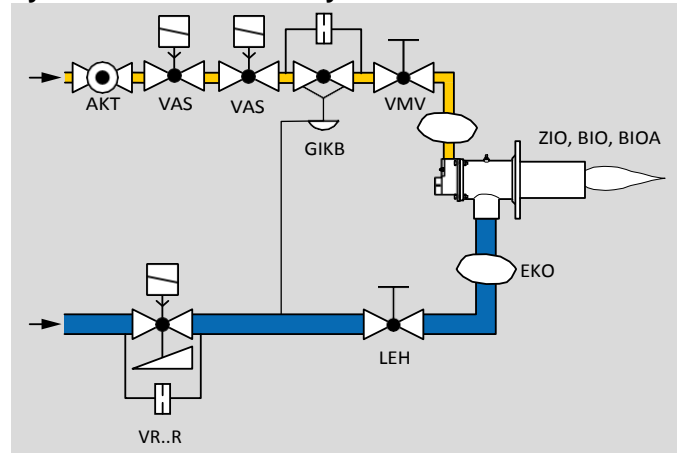

The burner is ignited at a defined pilot rate. In the gas circuit, the pilot rate is achieved via a bypass nozzle in the GIKB and in the air circuit, via a hole in the air valve, for example. This burner system can thus be used regardless of the burner capacity. The burner capacity is switched cyclically between HIGH fire and LOW fire by opening and closing the air valve. The air control valve should open and close slowly.



บริษัท เอดีดี เฟอร์เนส จำกัด

ADD FURNACE CO.,LTD.

44 ซอยบรมราชชนนี 70 ถนนบรมราชชนนี แขวงศาลาธรรมสพน์ เขตทวีวัฒนา กรุงเทพฯ 10170

โทร: 02-888-3472 โทร: ออกแบบ:08-08-170-170 แฟกซ์: 02-888-3258

<https://www.add-furnace.com> E-mail: sales@add-furnace.com

1 Certification

Eurasian Customs Union



The product BIO/BIOA/BIOW/ZIO/ZIOW meets the technical specifications of the Eurasian Customs Union.

Declaration of Incorporation pursuant to the Machinery Directive

The burner BIO/BIOA/BIOW/ZIO/ZIOW complies with the requirements of EN 746-2 and the Machinery Directive 2006/42/EC. This is confirmed by the manufacturer's Declaration of Incorporation.



บริษัท เอดีดี เฟอร์เนส จำกัด

ADD FURNACE CO.,LTD.

44 ซอยบรมราชชนนี 70 ถนนบรมราชชนนี แขวงศาลาธรรมสพน์ เขตทวีวัฒนา กรุงเทพฯ 10170

โทร: 02-888-3472 โทร: ออกแบบ:08-08-170-170 แฟกซ์: 02-888-3258

<https://www.add-furnace.com> E-mail: sales@add-furnace.com

2 Mechanical construction

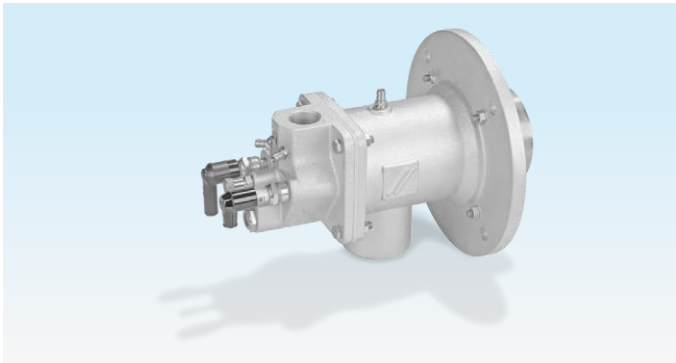

The burner is composed of the following modules: burner body, burner insert and burner tube. This structure enables easy adjustment to suit the respective process or integration into existing systems. Maintenance and repair times are reduced, and existing furnace installations can easily be converted.

3.1 Burner body (furnace flange)

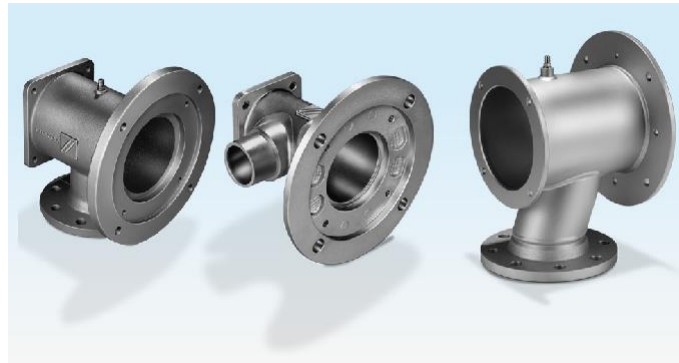

Burner bodies: BIO, BIO, ZIO

The burner is secured to the furnace by the burner body. The burner body accommodates the burner insert and the burner tube, and routes the combustion air. The combustion air pressure can be measured using an air pressure test nipple.



บริษัท เอดีดี เฟอร์เนส จำกัด

ADD FURNACE CO.,LTD.

44 ซอยบรมราชชนนี 70 ถนนบรมราชชนนี แขวงศาลาธรรมสพน์ เขตทวีวัฒนา กรุงเทพฯ 10170

โทร: 02-888-3472 โทร: ออกแบบ:08-08-170-170 แฟกซ์: 02-888-3258

https://www.add-furnace.com E-mail: sales@add-furnace.com

With internal insulation (high temperature version)



BIO/WZIO/W

Burner bodies with insulation can be used for higher hot air temperatures of up to 600°C (1112°F). The insulation consists of vacuum-formed ceramic fibres (RCF = refractory ceramic fibre) with a specially hardened surface. Its purpose is to reduce the body surface temperature and protect the materials from overheating. To ensure that the air pressure test nipple remains cool, it is not installed directly on the body but at a distance from it.

3 .2 Burner insert

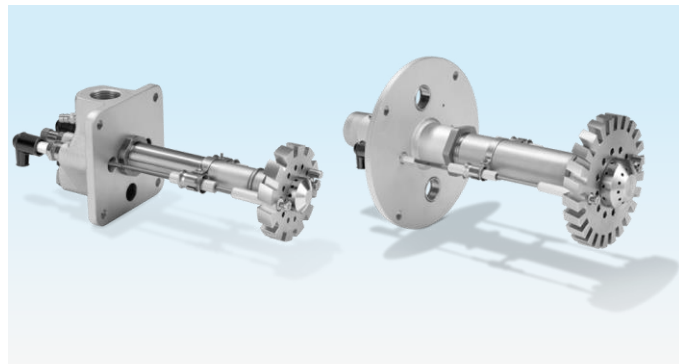

BIO, ZIO burner insert

The fuel gas is supplied to the burner head via the gas connection and the gas nozzle. The burners are nozzle-mixing burners. Gas and air are mixed only once they are in the burner head. This prevents explosive gases from being generated in the pipelines.

The gas connection flange assembly includes the sight glass, ground screw and spark plugs with right-angle terminal boots. For BIO 65 to 140, the connection flange is equipped with an integrated measuring orifice for easy measuring and flow adjustment for exact adjustment of the gas flow rate (BIOA without measuring orifice and without flow adjustment).

Spark electrode and flame rod are screwed into the connection flange and can be replaced without removing the burner insert.

A wide selection of burner heads ensures excellent combustion for the most diverse types of gases and applications.



บริษัท เอดีดี เฟอร์เนส จำกัด

ADD FURNACE CO.,LTD.

44 ซอยบรมราชชนนี 70 ถนนบรมราชชนนี แขวงศาลาธรรมสพน์ เขตทวีวัฒนา กรุงเทพฯ 10170

โทร: 02-888-3472 โทร: ออกแบบ:08-08-170-170 แฟกซ์: 02-888-3258

<https://www.add-furnace.com> E-mail: sales@add-furnace.com

3.2.1 Burners with integrated torch

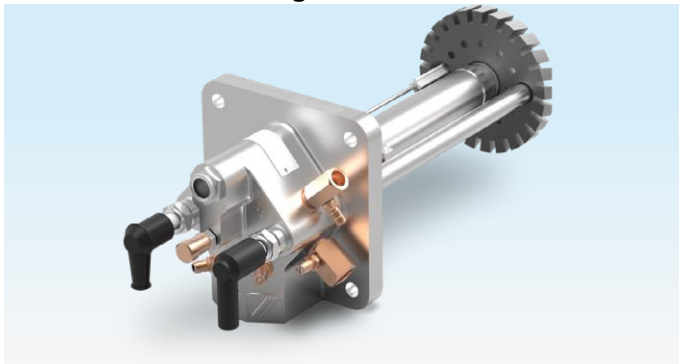

A complete pilot burner with separate gas and air connection is fitted to burners with an integrated torch instead of the spark electrode.

3.2.2 Heat-resistant, with purged electrodes



Burner insert BIO with purged electrodes

A heat-resistant version is available for burners with hot air up to 450°C, minimum cooling air and a maximum turn-

down. This version is characterized by a burner head made of heat-resistant steel, electrodes with an air connection and integrated flow adjustment. For use in forging furnaces, where flat flame burners are used predominantly, the heat-resistant burner head is also equipped with a partly ceramic gas nozzle.

3.2.3 High temperature version



Burner insert BIO for high temperature version

A high temperature version (HT version) is available for burners with hot air up to 600°C. This version is also characterized by a burner head made of heat-resistant steel and electrodes with an air connection. Compared to the heat-resistant version, among other things, the HT version has no integrated flow adjustment.



บริษัท เอดีดี เฟอร์เนส จำกัด

ADD FURNACE CO.,LTD.

44 ซอยบรมราชชนนี 70 ถนนบรมราชชนนี แขวงศาลาธรรมสพน์ เขตทวีวัฒนา กรุงเทพฯ 10170

โทร: 02-888-3472 โทร: ออกแบบ:08-08-170-170 แฟกซ์: 02-888-3258

<https://www.add-furnace.com> E-mail: sales@add-furnace.com

3 .3 Burner tube

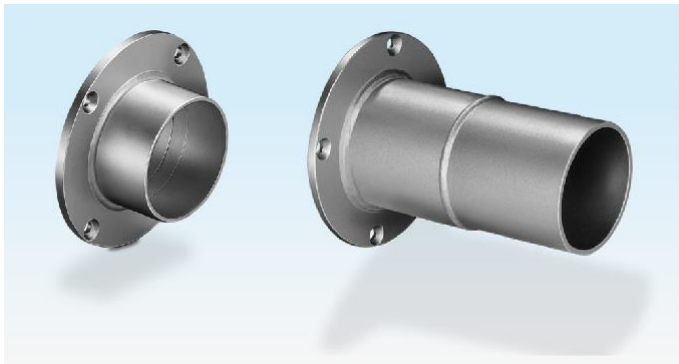

Different overall lengths enable adjustment to the furnace wall thickness of the system.

3 .3 .1 Burner tube in burner block

The burner head is positioned inside the burner tube. The burner block accommodates the burner tube and simultaneously acts as the combustion chamber for the complete combustion of the flame. The burner blocks are components of the refractory lining of the furnace and are usually supplied by the furnace manufacturer.

3 .3 .2 Burner tube with attachment tube

The burner head is positioned inside the burner tube. An attachment tube made of heat-resistant steel acts as the combustion chamber for the complete combustion of the flame for low- and medium-temperature applications.



บริษัท เอดีดี เฟอร์เนส จำกัด

ADD FURNACE CO.,LTD.

44 ซอยบรมราชชนนี 70 ถนนบรมราชชนนี แขวงศาลาธรรมสพน์ เขตทวีวัฒนา กรุงเทพฯ 10170

โทร: 02-888-3472 โทร: ออกแบบ:08-08-170-170 แฟกซ์: 02-888-3258

https://www.add-furnace.com E-mail: sales@add-furnace.com

4 Function

4.1 Burners with spark electrode

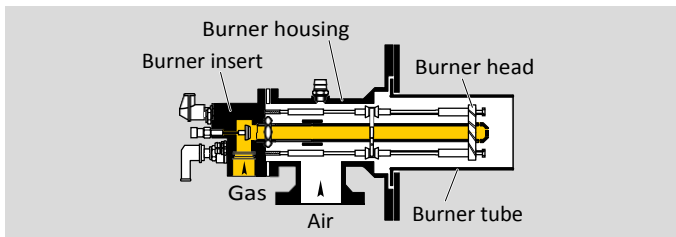

BIO, BIOA, BIOW

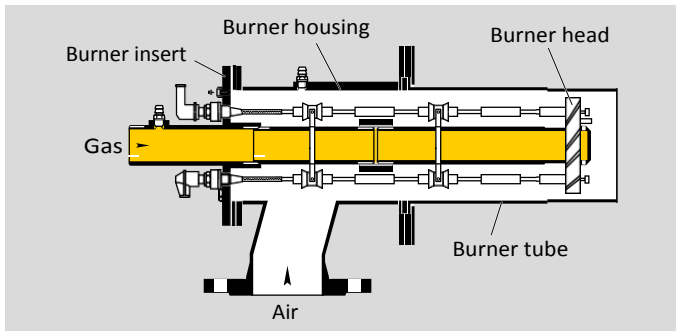

ZIO, ZIOW

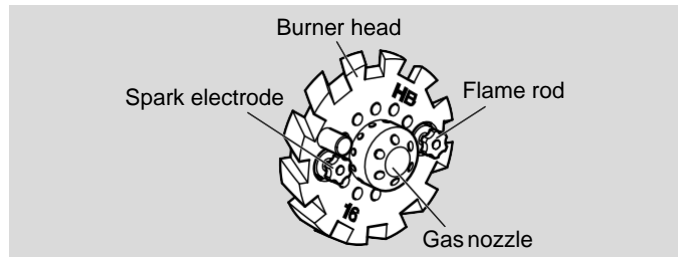

Burner head

The burner control unit opens the gas and air control valves. Gas flows through the gas connection flange and air flows through the burner body as far as the nozzle-mixing burner head.

The combustible gas/air mixture is produced downstream of the burner head. Slots and holes in the air disc vary the angle of twist of the combustion air and determine the flame shape. Depending on the gas type, the geometry of the gas nozzle varies.

The gas/air mixture is electrically ignited directly by a spark electrode or a torch. A flame forms which is monitored using a flame rod or optionally using a UV sensor.

The choice of the respective combustion chamber material and geometry is primarily determined by the process.

Using burner blocks, almost any flame shape and outlet velocity can be achieved.

For low temperature applications, a combustion chamber made of heat-resistant steel (burner tube with attachment tube) can be used. The flame is stabilized by the attachment tube.



บริษัท เอดีดี เฟอร์เนส จำกัด

ADD FURNACE CO.,LTD.

44 ซอยบรมราชชนนี 70 ถนนบรมราชชนนี แขวงศาลาธรรมสพน์ เขตทวีวัฒนา กรุงเทพฯ 10170

โทร: 02-888-3472 โทร: ออกแบบ:08-08-170-170 แฟกซ์: 02-888-3258

<https://www.add-furnace.com> E-mail: sales@add-furnace.com

4.2 Burners with integrated torch

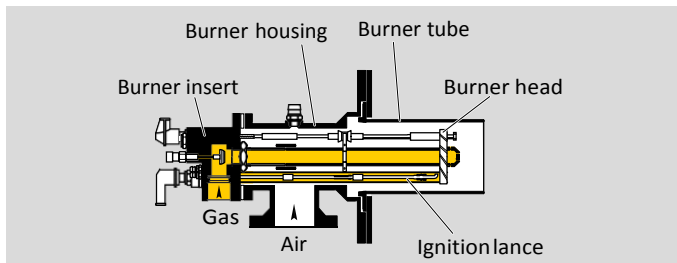

BIO

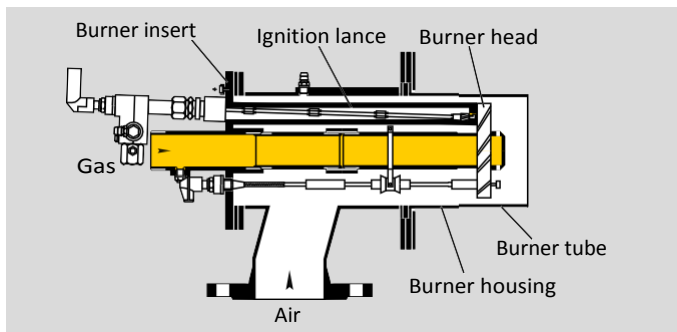

ZIO

In the case of ignition with a torch, the pilot burner is supplied with gas and air before the main burner starts. The gas/air mixture is electrically ignited directly by the torch electrode and is then monitored by this electrode using ionization control.

Once the torch has been successfully ignited, the main burner is ignited via the torch.



บริษัท เอดีดี เฟอร์เนส จำกัด

ADD FURNACE CO.,LTD.

44 ซอยบรมราชชนนี 70 ถนนบรมราชชนนี แขวงศาลาธรรมสพน์ เขตทวีวัฒนา กรุงเทพฯ 10170

โทร: 02-888-3472 โทร: ออกแบบ:08-08-170-170 แฟกซ์: 02-888-3258

<https://www.add-furnace.com> E-mail: sales@add-furnace.com

5 Selection

5.1 Capacity data

As far as the capacity data are concerned, it should be noted that the capacities in kW and the energy densities in kWh/m³ relate to the lower heating value Hu. Capacities quoted in BTU/h and energy densities in BTU/scf relate to the higher heating value Ho.

Units	Relative to
kW	Lower heating value Hu
kWh/m ³	Lower heating value Hu
BTU/h	Higher heating value Ho
BTU/scf	Higher heating value Ho

5.2 Burner type

Type	Body material	Air temperature	
		°C	°F
BIOA	AlSi	< 200	< 392
BIO	Cast steel	< 450	< 842
ZIO	St	< 450	< 842
BIOW	St with internal insulation	< 600	< 1112
ZIOW	St with internal insulation	< 600	< 1112

5.3 Burner size

Burner size	Burner capacity	
	kW	103 BTU/h
BIO 50	40	151
BIO, BIOA, BIOW 65	90	340
BIO, BIOW 80	150	567
BIO, BIOW 100	230	870
BIO, BIOW 125	320	1210
BIO, BIOW 140	450	1702
ZIO, ZIOW 165	630	2382
ZIO, ZIOW 200	1000	3782



5.4 Burner head selection

The choice of burner head depends on the **use**, gas type and **variant**.

5.4.1 Use

Use	Burner head code letter	Air temperature		Housing with internal insulation	Furnace temperature		Burner block
		°C	°F		°C	°F	
Cold air	R	< 150	< 302	–	< 1100	< 2012	Cylindrical, open cone, closed cone (A, B, C)
Hot air/high furnace temperature	H	< 500	< 932	> 450°C Luvo => BIOW/ZIOW	< 1500	< 2732	Cylindrical, closed cone (B, C)
High temperature version	H(..E)..H	< 600	< 1112	BIOW/ZIOW	< 1600	< 2912	Closed cone (C with smallest outlet diameter in this size)**
Flat flame	K	< 150	< 842	Optional for BI-OW/ZIOW	< 1100	< 2012	Flat flame block (D)
Flat flame, heat-resistant, with purged electrodes	K(..E)	< 450	< 842	Optional for BI-OW/ZIOW	< 1350	< 2462	Flat flame block (D)

* > 1500°C (2642°F) only UV control possible; insulate the burner tube with L1 - L2 = 15 mm (Tmax on burner tube: 1000°C (1832°F)).

** Select L10 max. in accordance with the burner block table.

The choice of burner head depends, among other things, on the air temperature, the furnace chamber temperature and the resulting minimum low-fire rate, see page 31 (Minimum low-fire rate). The required purge/cooling air when switched off depends on the furnace chamber temperature and the burner head, see page 31 (Purge air/cooling air).



บริษัท เอดีดี เฟอร์เนส จำกัด

ADD FURNACE CO.,LTD.

44 ซอยบรมราชชนนี 70 ถนนบรมราชชนนี แขวงศาลาธรรมสพน์ เขตทวีวัฒนา กรุงเทพฯ 10170

โทร: 02-888-3472 โทร: ออกแบบ:08-08-170-170 แฟกซ์: 02-888-3258

https://www.add-furnace.com E-mail: sales@add-furnace.com

5.4.2 Gas type

For operation with changing gas types, see page 29
(Operation with changing gas types).

Gas type	Code letter	Heating value range		Density	
		kWh/m ³ (n)	BTU/scf	kg/m ³	lb/scf
Natural gas L and H quality	B	8–12	810–1215	0.7–0.9	0.041–0.053
Propane, propane/butane, butane	M	25–35	2480–3472	2.0–2.7	0.118–0.159
Propane, propane/butane, butane	G	25–35	2560–3474	2.0–2.7	0.118–0.159
Coke oven gas, town gas	D	4–5	413–517	0.4–0.6	0.024–0.035
Gas	L	< 3	< 288	< 1.15	< 0.068
Biogas	F	4.5–6.5	456–660	1.4–1.16	0.083–0.069

1) For $\lambda < 0.9$ or when using the BIO 50.

Heating value range < 1.7 on request.

Only with reduced capacity and with R burner head for composition of the fuel gas CH₄ = 45–65%, remaining component CO₂ or N₂. Suitable burner sizes on request.

Low calorific value gas

Low calorific value gases have a heating value of less than 3 kWh/m³ (less than 288 BTU/scf). The fuel gas composition must be checked in advance. Operation with low calorific value gas is only possible using H burner heads. The capacity of the

burner heads for low calorific value gas is reduced. The recommended maximum outlet velocity is 80 m/s. On versions with integrated torch, it should be noted that the torch cannot be operated with low calorific value gas.

Burner*	Rated capacity		Burner block outlet diameter	
	kW	10 BTU/h	mm	inch
BIO 65HLR	45	170	33	1.3
BIO 80HLR	75	284	40	1.57
BIO 100HLR	115	435	50	1.97
BIO 125HLR	160	605	66	2.6
BIO 140HLR	225	851	70	2.76

* Other sizes on request.

5.4.3 Variant

Variant	Code letter	Feature
Integrated torch	L	Capacity of the torch approx. 1.5 kW (5670 BTU/h). The gas type for the torch is automatically defined by the selection of the gas type for the burner head (low calorific value gas and biogas not possible). Size BIO 50 cannot be fitted with an integrated torch.
Reduced capacity	R	In conjunction with low calorific value gas and biogas. Only with burner block type C.



บริษัท เอดีดี เฟอร์เนส จำกัด

ADD FURNACE CO.,LTD.

44 ซอยบรมราชชนนี 70 ถนนบรมราชชนนี แขวงศาลาธรรมสพน์ เขตทวีวัฒนา กรุงเทพฯ 10170

โทร: 02-888-3472 โทร: ออกแบบ:08-08-170-170 แฟกซ์: 02-888-3258

https://www.add-furnace.com E-mail: sales@add-furnace.com

5.5 Field of application

For optimal operation, the combustion chamber and burner head are combined according to the field of application.

Burners which are not used in combination with a burner block are fitted with a burner attachment tube in order to stabilize the flame.

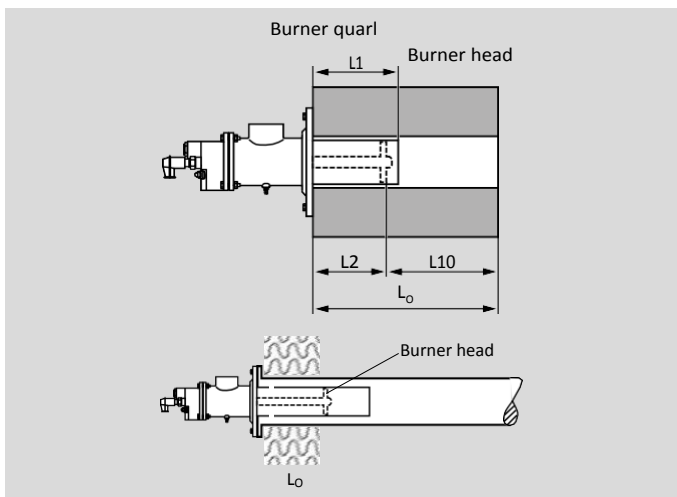



บริษัท เอดีดี เฟอร์เนส จำกัด

ADD FURNACE CO.,LTD.

44 ซอยบรมราชชนนี 70 ถนนบรมราชชนนี แขวงศาลาธรรมสพน์ เขตทวีวัฒนา กรุงเทพฯ 10170

โทร: 02-888-3472 โทร: ออกแบบ:08-08-170-170 แฟกซ์: 02-888-3258

https://www.add-furnace.com E-mail: sales@add-furnace.com

5.5.1 Burners with burner block

Field of application	Illustration	Combustion chamber	Control	Burner head	Max . capacity	Remark
Industrial furnaces, open combustion chambers	A	Open cone	Modulating	R	100%	Recommended for cold-air operating mode only, otherwise the nitric oxide values are too high
Industrial furnaces, open combustion chambers	B	Cylindrical	ON/OFF	R, H	100%	Normal to medium flow velocity
Industrial furnaces, open combustion chambers	C	Closed cone	ON/OFF	R, H	approx. 80%	Medium to high velocity, rated capacity depending on the diameter
Industrial furnaces, open combustion chambers	C	Closed cone	Modulating	H(..E)	approx. 75%	(30% of the rated capacity if T furnace is 1450°C or higher)
Industrial furnaces, open combustion chambers	D	Flat flame block	ON/OFF	K	100%	With modulating control, limited turndown ($\geq 40\%$)
Forging furnaces, open combustion chambers	D	Flat flame block	ON/OFF	K(...E)	100%	Hot air, only staged control possible (min. capacity = 50% of the rated capacity)

Burner block type

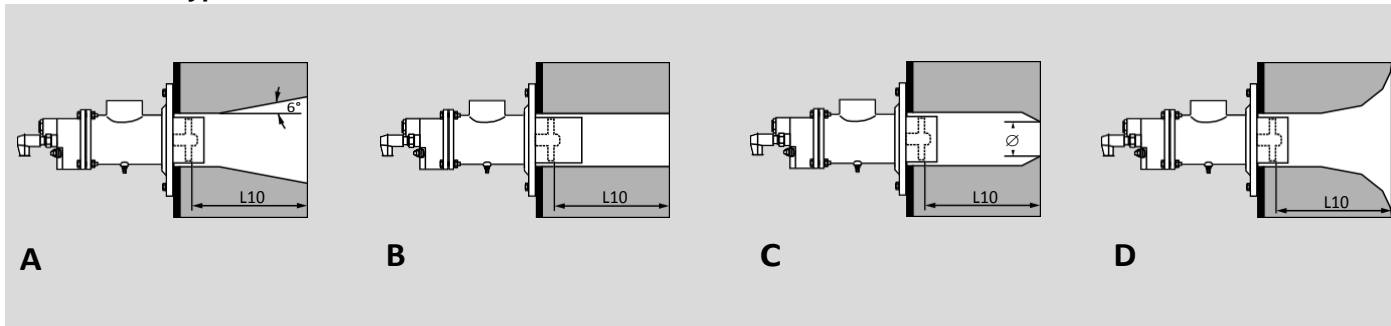

For further information on burner block dimensions see the burner block tables at www.docuthek.com



บริษัท เอดีดี เฟอร์เนส จำกัด

ADD FURNACE CO.,LTD.

44 ซอยบรมราชชนนี 70 ถนนบรมราชชนนี แขวงศาลาธรรมสพน์ เขตทวีวัฒนา กรุงเทพฯ 10170

โทร: 02-888-3472 โทร: ออกแบบ:08-08-170-170 แฟกซ์: 02-888-3258

https://www.add-furnace.com E-mail: sales@add-furnace.com

Burner tube length in burner block

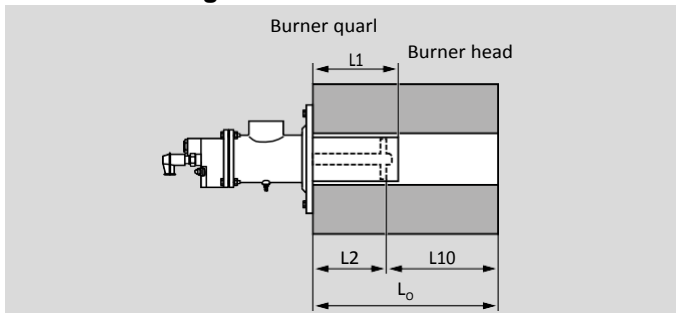

Calculating the burner tube length

A web app for calculating the burner tube length is available at www.adlatus.org.

Legend

L1 = Burner tube length
L2 = Position of burner head
LF = Furnace wall thickness
L10 = Burner chamber length

Calculation example

L2 should be appropriately selected, so that the burner head extends into the burner block. The following lengths are available for L2:

35, 135, 235, 335 mm, etc.

The burner chamber length L10 must be observed to ensure optimum flame formation and stable burner operation – see burner block (Type of document: General info) at www.docuthek.com

To determine L2: $L2 = LF - L10$

The burner tube length (L1) is predefined, depending on the burner head R, K or H:

R, K burner head:

$L1 = L2 + 15 \text{ mm}$ ($L1 = L2 + 0.591 \text{ inch}$)

H burner head:

$L1 = L2 + 65 \text{ mm}$ ($L1 = L2 + 2.56 \text{ inch}$)



บริษัท เอดีดี เฟอร์เนส จำกัด

ADD FURNACE CO.,LTD.

44 ซอยบรมราชชนนี 70 ถนนบรมราชชนนี แขวงศาลาธรรมสพน์ เขตทวีวัฒนา กรุงเทพฯ 10170

โทร: 02-888-3472 โทร: ออกแบบ:08-08-170-170 แฟกซ์: 02-888-3258

https://www.add-furnace.com E-mail: sales@add-furnace.com

5.5.2 Burners with burner attachment tube

Field of application	Illustration	Combustion chamber	Control	Burner head	Max . capacity	Remark
Radiant tube heating	E	Burner with attachment tube and purge air bore holes	ON/OFF	H	100%	Note the capacity of the radiant tube in accordance with the manufacturer's specifications. A draught blocker must be fitted on the flue gas side. Only with cold air and where the furnace temperature is < 850°C.
Hot air generation	F	Burner with attachment tube and purge air bore holes, flame tube FPT	ON/OFF	R	100%	Protection of the flame from cooling is ensured by using a flame tube FPT at flow velocities of > 15 m/s. Only with cold air and where the furnace temperature is < 600°C.

Radiant tube heating

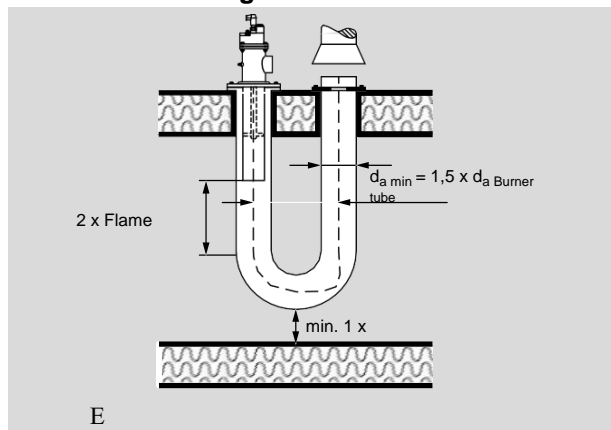

When using the burner in radiant tubes or flame tubes, the extended burner tube (attachment tube) acts as the combustion chamber. Burners for this field of application are supplied with purge air bore holes for optimal flame stability. The burner with attachment tube is only suitable for cold air

applications. Maximum furnace temperature approx. 850°C (1562 °F).

The outlet diameter of the radiant tube must be reduced to the point where a pressure loss of approx. 10 mbar (3.94 "WC) occurs at the burner's rated capacity. When installed in a U-shaped radiant tube, the distance between the burner attachment tube and the first elbow/bend must be at least twice the flame length.



บริษัท เอดีดี เฟอร์เนส จำกัด

ADD FURNACE CO.,LTD.

44 ซอยบรมราชชนนี 70 ถนนบรมราชชนนี แขวงศาลาธรรมสพน์ เขตทวีวัฒนา กรุงเทพฯ 10170

โทร: 02-888-3472 โทร: ออกแบบ:08-08-170-170 แฟกซ์: 02-888-3258

https://www.add-furnace.com E-mail: sales@add-furnace.com

Hot air generation

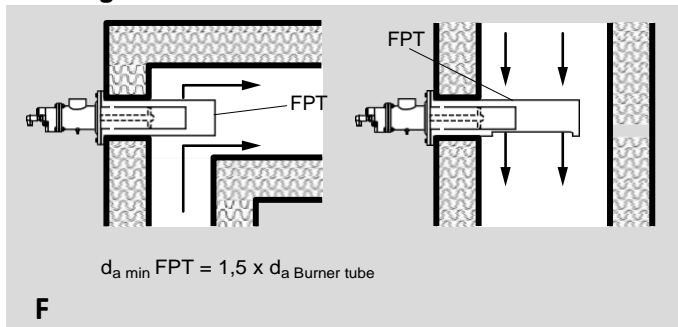

To generate hot air at a furnace temperature of $< 600^\circ\text{C}$ ($< 1112^\circ\text{F}$), burners with an attachment tube and purge air bore holes are used. The burner with attachment tube is only suitable for cold air applications.

At flow velocities of $> 15 \text{ m/s}$, the flame tube FPT is used to protect the flame from being cooled. At flow velocities of $< 15 \text{ m/s}$, the flame tube FPT is not needed.

Flame tube FPT

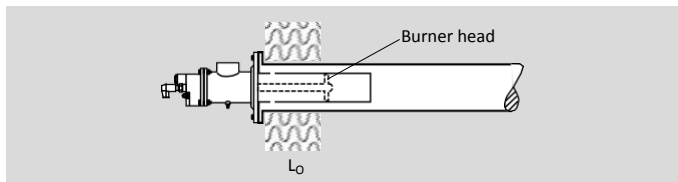

Legend

L1 = Burner tube length

L2 = Position of burner head $L_F =$

Furnace wall thickness

L_{1-2} = Attachment tube length (distance from burner head to burner tube end)

Attachment tube lengths (L_{1-2}):

BIO, BIOA, ZIO	H burner head		R burner head	
	mm	inch	mm	inch
50	115	4.53	115	4.53
65	115	4.53	115	4.53
80	165	6.5	165	6.5
100	165	6.5	165	6.5
125	215	8.46	215	8.46
140	265	10.4	265	10.4
165	265	10.4	165	6.5
200	315	12.4	215	8.46

1) For radiant tube only

2) For hot air generation only

L2 should be appropriately selected, so that the burner head is positioned near the interior furnace wall:

$L2 = LF \pm 50 \text{ mm}$ ($L2 = LF \pm 1.97 \text{ inch}$)

The burner tube length (L1) is calculated by adding L2 to the attachment tube length (L_{1-2}):

$L1 = L2 + L_{1-2}$

Dimensioning the flame tube FPT

A web app for dimensioning the flame tube FPT is available at www.adlatus.org.



บริษัท เอดีดี เฟอร์เนส จำกัด

ADD FURNACE CO.,LTD.

44 ซอยบรมราชชนนี 70 ถนนบรมราชชนนี แขวงศาลาธรรมสพน์ เขตทวีวัฒนา กรุงเทพฯ 10170

โทร: 02-888-3472 โทร: ออกแบบ:08-08-170-170 แฟกซ์: 02-888-3258

<https://www.add-furnace.com> E-mail: sales@add-furnace.com

5 .6 High temperature version

Special burner bodies and burner inserts are available for high temperature applications for sizes 65–200, see page 10 (Mechanical construction). These versions are available for natural gas, LPG and coke oven gas.

The high temperature versions can be identified by the code letter “H” at the end of the burner type code.

High temperature versions are prepared for UV control. The UV sensor is to be ordered separately.



บริษัท เอดีดี เฟอร์เนส จำกัด

ADD FURNACE CO.,LTD.

44 ซอยบรมราชชนนี 70 ถนนบรมราชชนนี แขวงศาลาธรรมสพน์ เขตทวีวัฒนา กรุงเทพฯ 10170

โทร: 02-888-3472 โทร: ออกแบบ:08-08-170-170 แฟกซ์: 02-888-3258

https://www.add-furnace.com E-mail: sales@add-furnace.com

5.7 Selection table

Option	BIO	BIOA	BIO/ZIO	BIOW/ZIOW
Burner size	50	65	65, 80, 100, 125, 140, 165, 200	65, 80, 100, 125, 140, 165, 200
Use	R, H, K	R, H, K	R, H, K	R, H, K
Gas type	B, G, D, L, F	B, G, M, D, L, F	B, G, M, D, L, F	B, G, M, D, L, F
Variant*	-	R	L, R	L, R
Burner tube length	-50, -100,...	-50, -100,...	-50, -100,...	-50, -100,...
Position of burner head	/35-, 135-,...	/35-, 135-,...	/35-, 135-,...	/35-, 135-,...
Burner head	-(1) to (199)	-(1) to -(199)	-(1) to -(199), -(1E) to -(199E)	-(1) to -(199), -(1E) to -(199E)
Construction stage	A-Z	A-Z	A-Z	A-Z
Version	B	B	B, H	B, H

* Variant R for gas types L and F only

Order example

BIO 80HB-100/35-(16)F

5.7.1 Burner type

Furnace temperature	< 1100°C < 2012°F	< 1100°C < 2012°F	< 1500°C < 2732°F	< 1600°C < 2912°F	< 1100°C < 2012°F	< 1350°C < 2462°F
Combustion air temperature	< 150°C < 302°F	< 200°C < 392°F	< 450°C < 842°F	< 600°C < 1112°F	< 150°C < 302°F	< 450°C < 842°F
Burner head code letter	R		H		K	
Type	Size					
BIOA	65	◆	◆			
BIO/ZIO	50-200	◆	◆	◇	⊗	
BIO/ZIO...(E)	80-200		◆			⊗
BIOW/ZIOW...(E)..H	65-200			◇		⊗

◆ = Turndown 1:10 or ON/OFF

◇ = Limited turndown or ON/OFF

⊗ = ON/OFF



บริษัท เอดีดี เฟอร์เนส จำกัด

ADD FURNACE CO.,LTD.

44 ซอยบรมราชชนนี 70 ถนนบรมราชชนนี แขวงศาลาธรรมสพน์ เขตทวีวัฒนา กรุงเทพฯ 10170

โทร: 02-888-3472 โทร: ออกแบบ:08-08-170-170 แฟกซ์: 02-888-3258

<https://www.add-furnace.com> E-mail: sales@add-furnace.com

5.7.2 Type code

BIO, ZIO	Burner for gas
BIOA	Burner for gas, with aluminium housing
BIOW, ZIOW	Burner for gas, with ceramic fibre insulation (RCF)
50-200	Burner size
R	Cold air
K	Flat flame
H	Hot air/high furnace temperature
B	Natural gas
D	Coke oven gas, town gas
G	Propane, propane/butane, butane
M	Propane, propane/butane, butane (with mixer)
L	Low calorific value gas
F	Biogas
L	Torch
R	Reduced capacity
-X	X mm length of steel tube as of furnace flange (L1)
/X	X mm distance from furnace flange to front edge of burner head (L2)
-(X)	Burner head identifier
A-Z	Construction stage
B	With purge air bore holes
H	High temperature version



บริษัท เอดีดี เฟอร์เนส จำกัด

ADD FURNACE CO.,LTD.

44 ซอยบรมราชชนนี 70 ถนนบรมราชชนนี แขวงศาลาธรรมสพน์ เขตทวีวัฒนา กรุงเทพฯ 10170

โทร: 02-888-3472 โทร: ออกแบบ:08-08-170-170 แฟกซ์: 02-888-3258

https://www.add-furnace.com E-mail: sales@add-furnace.com

6 Project planning information

6.1 Installation

Installation position as required.

Gas and air connection: can be rotated in 90° steps. Install flexible tubes or bellows units to prevent mechanical stress or vibrations.

Install and insulate the burner in order to avoid any overheating of the components during operation. Where applicable, purge air must be used to prevent ingress of aggressive gases and thermal overload of components.

6.2 Flat flame burner spacing

In the case of flat flame burners, the spacing between burners and the distance from the furnace wall must be observed.

Burner	Flat flame diameter		Minimum distance X	
	mm	inch	mm	inch
BIO 50	300	11.8	330	13
BIO 65	400	15.7	450	17.7
BIO 80	550	21.7	600	23.6
BIO 100	700	27.6	800	31.5
BIO 125	830	32.7	900	35.4
BIO 140	1000	39.4	1100	43.3
ZIO 165	1200	47.2	1300	51.2
ZIO 200	1500	59.1	1600	43

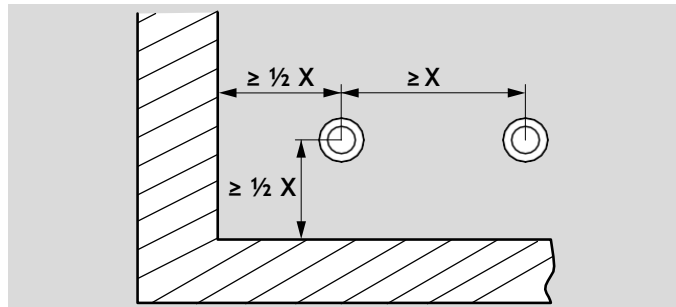

6.3 Ignition

6.3.1 Ignition with reduced capacity

The burners can be ignited near-stoichiometrically within a range of 10–40% of the rated capacity. Exceptions are noted in the operating characteristic diagram, see www.docuthek.com (registration required).

6.3.2 Ignition with defined pilot rate

If a defined air volume is designated for ignition, the burners can be ignited via the pneumatic ratio control system. As an alternative to the pneumatic ratio control system, the gas volume can be released by a bypass valve.

6.3.3 Ignition without defined pilot rate

(flying burner start/ignition against the opening valves) The burner can be ignited in the interim period while the air control valve is opening fully. Either slow opening air and gas valves or a slow opening air valve in a pneumatic ratio control system must be used for this purpose.



บริษัท เอดีดี เฟอร์เนส จำกัด

ADD FURNACE CO.,LTD.

44 ซอยบรมราชชนนี 70 ถนนบรมราชชนนี แขวงศาลาธรรมสพน์ เขตทวีวัฒนา กรุงเทพฯ 10170

โทร: 02-888-3472 โทร: ออกแบบ:08-08-170-170 แฟกซ์: 02-888-3258

<https://www.add-furnace.com> E-mail: sales@add-furnace.com

6 .4 Recommended ignition transformer



TZI, TGI

We recommend ignition transformers TZI or TGI with a voltage of > 7.5 kV and an output current of > 12 mA for the burners. An ignition voltage of 5 kV for the torch is recommended.

6 .5 Non-return gas valve

Non-return gas valves are not required, since the burners are of the nozzle-mixing type.

6 .6 Flame control

The burners BIO/ZIO are supplied as standard with a flame rod for flame control.

6 .6 .1 Burners with UV sensor

As an option, control is possible with a UV sensor (BIO 50 on request only). This replaces the flame rod and is fitted to the same connection on the burner. An installation set is required for this purpose, see page 35 (UV sensor). The

burners of sizes 65 to 100 also require a viewing duct which is included in the installation set (for modification instructions, see www.docuthek.com /registration required). If the burners are ordered with an installed UV sensor, the various items must be ordered in a group.

6 .6 .2 Burners with torch

Burners with an integrated torch have two electrodes for flame control. One of them is used to ignite and monitor the pilot flame. The other electrode is designed for monitoring the main flame (UV control on request only).

6 .7 Operation with changing gas types

Burners for natural gas with an H burner head can also be operated with pure propane. The turndown of the burner is then around 1:3. Operation with a mixture of propane and air (the same Wobbe index as natural gas) is also possible. Turndown is around 1:5. The low-fire rate must be adjusted with excess air to prevent soot formation.



6.8 Hot air operating mode

The total input into the process in hot air operating mode is calculated from the total gas capacity and the energy content of the hot air. The diagram shows the relative total capacity as a function of the air temperature. Operating the burners at rated capacity is also possible using hot air.

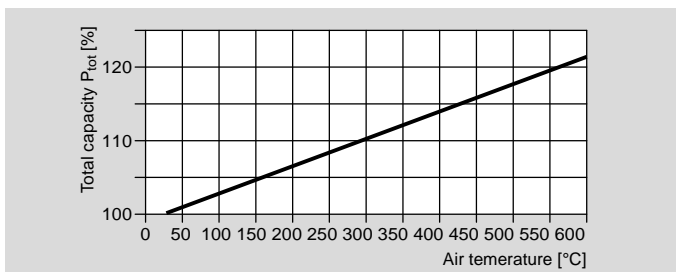

For applications with air preheating via a central recuperator, hot air compensation is performed by changing the air pressure depending on the air temperature. The air pressure is increased as the air temperature rises in order to keep the air index λ constant.

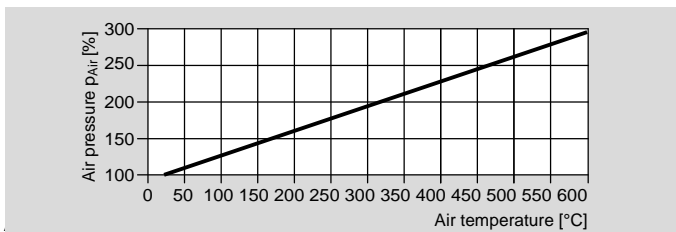

counterpressure also increases. At a constant gas pressure on the burner, the gas volume decreases (reduction < 5%) as the air temperature increases. Accordingly, the air pressure must be increased less than at a constant gas volume.

6.9 Extended burner head identifier

The following special burner heads are available on request for special applications:

Identifier	Special version
A	Heat-resistant
B	Sulphur-resistant
D	Electrodes with air connection
E	Heat-resistant, with purged electrodes

The version of the burner head is indicated in the type code after the burner head identifier: -(1A) to (199E).

6.10 Contaminated fuel gases

Maximum allowable amount of impurities

Impurities	Density
Sulphur (S)	$\leq 300 \text{ mg/m}^3$
Hydrogen sulphide (H ₂ S)	$\leq 1500 \text{ mg/m}^3$
Naphthalene (C ₁₀ H ₈)	$\leq 200 \text{ mg/m}^3$
Tar	$\leq 500 \text{ mg/m}^3$

Condensation in wetted components is prohibited. Details on further or other impurities available upon request.



บริษัท เอดีดี เฟอร์เนส จำกัด

ADD FURNACE CO.,LTD.

44 ซอยบรมราชชนนี 70 ถนนบรมราชชนนี แขวงศาลาธรรมสพน์ เขตทวีวัฒนา กรุงเทพฯ 10170

โทร: 02-888-3472 โทร: ออกแบบ:08-08-170-170 แฟกซ์: 02-888-3258

https://www.add-furnace.com E-mail: sales@add-furnace.com

6.11 Minimum low-fire rate

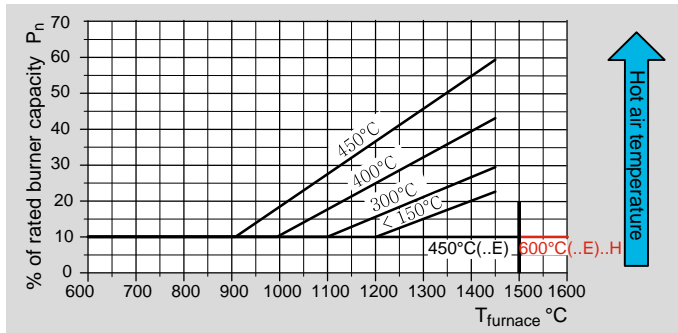

To avoid thermal overload of the burner head, a minimum low-fire rate is recommended, depending on the hot air and furnace temperature, see diagram.

In the heat-resistant and high temperature version, the minimum low-fire rate is reduced to 10% of the rated burner capacity up to a maximum furnace temperature of 1500°C or 1600°C.

On burner heads with the code letter "R", an extremely high turndown of > 1:30 can be achieved if they are operated at low-fire rate with excess air ($\lambda > 3$) (size 50 on request). When the burner is switched off, the air volume at low-fire rate is more than sufficient to cool the burner.

Calculating the low-fire rate

A web app for calculating the low-fire rate is available at www.adlatus.org.

6.12 Purge air/cooling air

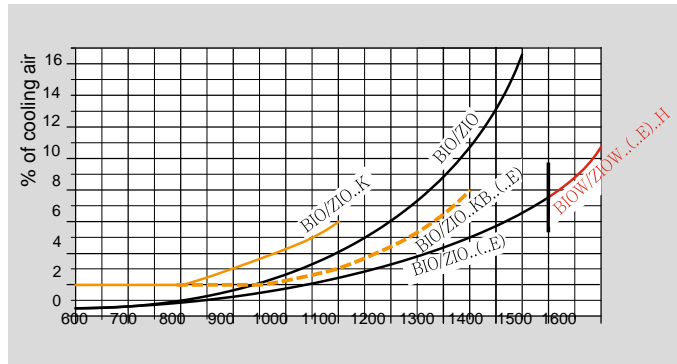

While the burner is switched off and depending on the furnace temperature, there must be a certain air flow in order to ensure safe ignition and monitoring of the burners, and for cooling the burner components.

The cooling air percentage specified in the diagram refers to the operating flow rate for air.

Example: BIO, ZIO

If 1000 mN³/h of combustion air is required at rated capacity and if the furnace is at a temperature of 1200°C, 60 m³/h of cooling air is required to cool the switched-off burner if the air temperature is 20°C, or 147 m³/h if the air temperature is 450°C. The air fan must remain switched on until the furnace has cooled down completely.

Calculating the purge/cooling air

A web app for calculating the purge/cooling air is available at www.adlatus.org.



บริษัท เอดีดี เฟอร์เนส จำกัด

ADD FURNACE CO.,LTD.

44 ซอยบรมราชชนนี 70 ถนนบรมราชชนนี แขวงศาลาธรรมสพน์ เขตทวีวัฒนา กรุงเทพฯ 10170

โทร: 02-888-3472 โทร: ออกแบบ:08-08-170-170 แฟกซ์: 02-888-3258

https://www.add-furnace.com E-mail: sales@add-furnace.com

6.12.1 Electrodes with air connection

The purged electrodes in high temperature version burners must be operated with a purge air volume of approx. 1.5 to 2.0 m³/h per electrode. This corresponds to a pressure of 10 to 15 mbar (3.94 to 5.91 "WC). The purge air may not be switched off until the furnace is cold and formation of condensation is no longer possible.

Pressures for purges electrodes

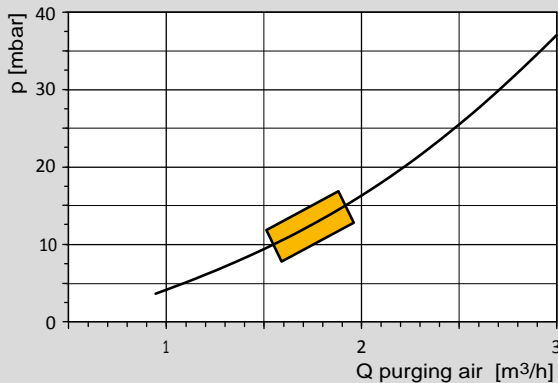

6.13 Emissions

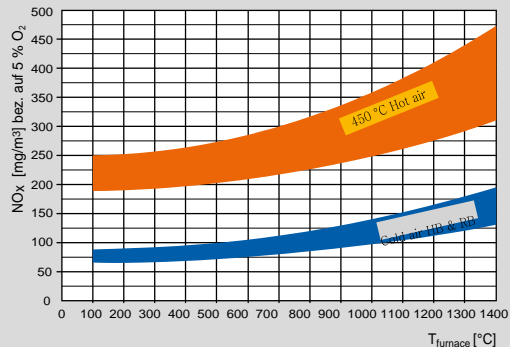

The NOx ranges shown apply to all burners BIO/ZIO at rated capacity (near-stoichiometric, operation with natural gas). Precise values on request since the NOx formation is influenced by the temperature, burner head, combustion chamber, furnace chamber, λ value and capacity.

Emissions for cold air operating mode are below the limit values stipulated by the German Clean Air Directive.

If operated with LPG, NOx values are approx. 25% higher. Values for operation with hot air of 450°C to 600°C or other fuel gases are available on request.



บริษัท เอดีดี เฟอร์เนส จำกัด

ADD FURNACE CO.,LTD.

44 ซอยบรมราชชนนี 70 ถนนบรมราชชนนี แขวงศาลาธรรมสพน์ เขตทวีวัฒนา กรุงเทพฯ 10170

โทร: 02-888-3472 โทร: ออกแบบ:08-08-170-170 แฟกซ์: 02-888-3258

<https://www.add-furnace.com> E-mail: sales@add-furnace.com

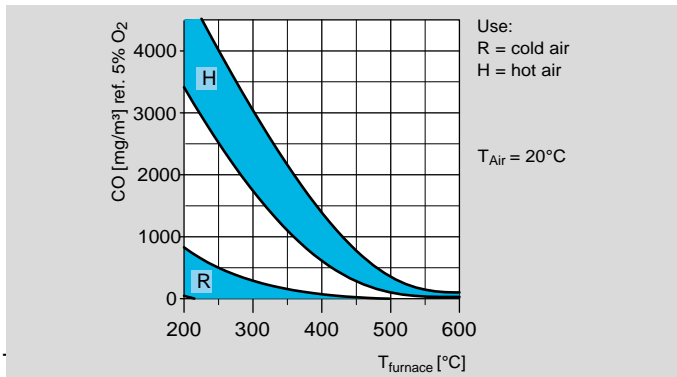

start (rated capacity, near-stoichiometric) and are significantly increased compared to normal operation. Precise values on request since the CO formation is influenced by the temperature, burner head, combustion chamber, control type, furnace chamber, λ value and capacity.

6.14 Gas line connection

We recommend the following to ensure optimum flow and burner operation with excess gas and to avoid incorrect measurements:

- Do not screw the manual valve directly into the burner.

To ensure an accurate measurement of the pressure differential on the integrated gas measuring orifice for the burner BIO/BIOA (size 65–140), the following applies to the design of the gas connection:

- Ensure undisturbed flow to the gas connection on the burner inlet for a distance of ≥ 5 DN.
- Use a bellows unit with the same nominal dimensions as the gas connection on the burner.

- Use a pipe elbow up to an angle of 90° with the same nominal dimensions as the gas connection on the burner.
- Only use reducing nipples with an external thread at both ends in order to reduce the nominal diameter on the burner (e.g. from 1" to $\frac{3}{4}$ ").

6.15 Air line connection

Ensure there is a bellows unit and an air adjusting cock upstream of the burner. It is recommended to install a measuring orifice FLS to determine the air flow rate.

6.16 Gaskets for higher connection pressures

The standard gaskets for the burners are suitable for a connection pressure of up to max. 100 mbar (gas and air).

Special gaskets are available on request for higher connection pressures of up to max. 500 mbar.

6.17 Condition on delivery

Gas and air connections are fitted opposite one another at the factory.

6.18 Intermittent operation

Note the opening and closing times of the control elements when determining the cycle times. Unnecessarily high numbers of operating cycles should be avoided.



บริษัท เอดีดี เฟอร์เนส จำกัด

ADD FURNACE CO.,LTD.

44 ซอยบรมราชชนนี 70 ถนนบรมราชชนนี แขวงศาลาธรรมสพน์ เขตทวีวัฒนา กรุงเทพฯ 10170

โทร: 02-888-3472 โทร: ออกแบบ:08-08-170-170 แฟกซ์: 02-888-3258

<https://www.add-furnace.com> E-mail: sales@add-furnace.com

6.19 Build up of noise

The noise volume of a burner in the open air is approx. 95 dBA at a distance of 1 m from the burner tube end (measured at an angle of < 45° to the flame).

If the burner is installed in a furnace, the noise volume is greatly reduced by the furnace insulation (with a 300 mm (11.8") fibre lining, the noise volume is approx. 75 dBA).

6 .20 Installation in a humid environment

The burners can be installed in a humid environment. It must be noted that the paint-coated burner body may rust in a humid environment. The corrosion will not affect the function of the burners. We recommend the application of an anti-corrosion coating in a humid environment to prevent corrosion.

6 .21 Heat guard

During operation, the burner body can reach surface temperatures of over 80°C. We recommend that warning signs and a contact guard be fitted, for example made of perforated sheet metal.



บริษัท เอดีดี เฟอร์เนส จำกัด

ADD FURNACE CO.,LTD.

44 ซอยบรมราชชนนี 70 ถนนบรมราชชนนี แขวงศาลาธรรมสพน์ เขตทวีวัฒนา กรุงเทพฯ 10170

โทร: 02-888-3472 โทร: ออกแบบ:08-08-170-170 แฟกซ์: 02-888-3258

https://www.add-furnace.com E-mail: sales@add-furnace.com

7 Accessories

7.1 Adapter set

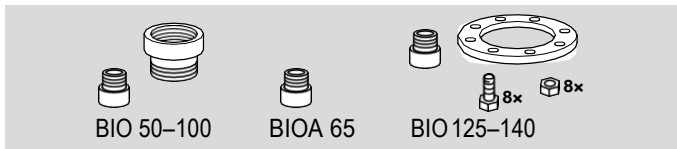

For connecting BIO and BIOA burners to NPT/ANSI connections.

Burner	Adapter set	Gas connection	Air connection	Order No .
BIO 50	BR 50 NPT	½"-14 NPT	1½"-11.5 NPT	74922630
BIO 65	BR 65 NPT	¾"-14 NPT	1½"-11.5 NPT	74922631
BIOA 65*	-	½"-14 NPT	Ø 1.89"	75456281
BIO 80	BR 80 NPT	¾"-14 NPT	2"-11.5 NPT	74922632
BIO 100	BR 100 NPT	1"-11.5 NPT	2"-11.5 NPT	74922633
BIO 125	BR 125 NPT	1½"-11.5 NPT	Ø 2.94"	74922634
BIO 140	BR 140 NPT	1½"-11.5 NPT	Ø 3.57"	74922635
ZIO 165	BR 165 NPT	1½"-11.5 NPT	Ø 4.57"	74922636
ZIO 200	BR 200 NPT	2"-11.5 NPT	Ø 6.72"	74922637

* An NPT thread adapter is required for connection to the gas circuit only.

Adapter set for BIOW and ZIOW on request.

BIO/BIOA/BIOW/ZIO/ZIOW · 10.19 · EN

7.1.1 Integrated torch connections

Nozzle set BR 65–140 with NPT thread is required for integrated torches (sizes 165 and 200 on request).

Gas type	Order No .
Natural gas	74922638
LPG	74922639

7.2 Ceramic paste

For avoiding cold-setting on screw connections after replacing burner components.
Order No.: 050120009.

7.3 UV sensor

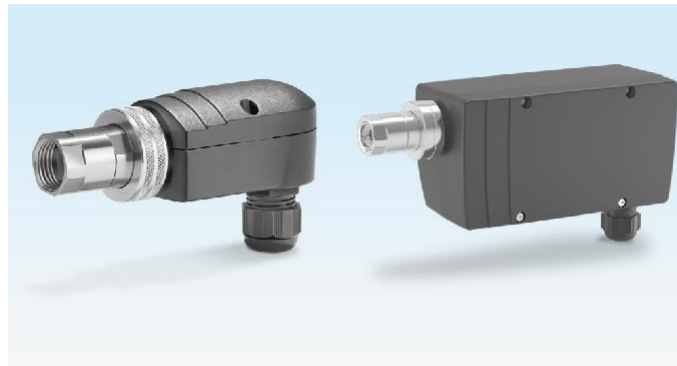

UVS 10, UVC

For monitoring gas burners in conjunction with flame detectors or automatic burner control units.

An installation set is required for installing the UV sensor on a burner BIO, BIOA or ZIO (on request).

UV sensor and installation set supplied on request.



บริษัท เอดีดี เฟอร์เนส จำกัด

ADD FURNACE CO.,LTD.

44 ซอยบรมราชชนนี 70 ถนนบรมราชชนนี แขวงศาลาธรรมสพน์ เขตทวีวัฒนา กรุงเทพฯ 10170

โทร: 02-888-3472 โทร: ออกแบบ:08-08-170-170 แฟกซ์: 02-888-3258

<https://www.add-furnace.com> E-mail: sales@add-furnace.com

7.4 Gasket sets for reverse flow pressure

For reverse flow pressures of $100 \text{ mbar} < p < 500 \text{ mbar}$.
“Gasket set BR XY 500 mbar” contains a mounting gasket, a gas housing gasket and a burner tube gasket made of pressure-resistant gasket material. The standard gaskets must be replaced with the gaskets from the gasket set for reverse flow pressure. The gasket sets are available on re- quest.



บริษัท เอดีดี เฟอร์เนส จำกัด

ADD FURNACE CO.,LTD.

44 ซอยบรมราชชนนี 70 ถนนบรมราชชนนี แขวงศาลาธรรมสพน์ เขตทวีวัฒนา กรุงเทพฯ 10170

โทร: 02-888-3472 โทร: ออกแบบ:08-08-170-170 แฟกซ์: 02-888-3258

<https://www.add-furnace.com> E-mail: sales@add-furnace.com

8 Technical data

Gas supply pressure and air supply pressure each depend on the use and gas type.

Gas and air pressures:

see burner diagrams at www.docuthek.com.

Special gaskets are available on request for air pressures of > 100 mbar (39.4"WC) (e.g. reverse flow pressure in the furnace).

Burner flow rate curves:

A web app to view the burner flow rate curves is available at www.adlatus.org

Gas types:

natural gas, LPG (gaseous), coke oven gas, town gas, low calorific value gas and biogas; other types of gas on request.

Combustion air:

The air must be dry and clean in all temperature conditions and must not contain condensate.

Overall lengths:

0 to 400 mm (0 to 15.7"), 100 mm (3.94")

length increments (other lengths available on request). Control

type:

staged: On/Off,

modulating: constant value.

Flame control:

with flame rod (UV control as an option).

Ignition:

direct spark ignition; torch as an option.

Burner body:

BIO: cast steel,

BIOA: AISi, ZIO:

St,

BIOW: St+internal insulation,

ZIOW: St + internal insulation.

Most of the burner components are made of corrosion-resistant stainless steel.

Ambient conditions:

-20°C to +180°C (68°F to 356°F) (outside the thermoprocessing system); no condensation permitted, painted surfaces may corrode.

Maximum furnace temperature:

BIO(W)/ZIO(W) in burner block: up to

1600°C (up to 2912°F),

BIO/ZIO with burner attachment tube: up to 600°C (up to 1112°F).

Maximum air temperature: BIO,

ZIO: up to 450°C (842°F), BIOA:

up to 200°C (392°F),

BIOW, ZIOW: up to 600°C (1112°F).

8.1 REACH Regulation

The device contains substances of very high concern which are listed in the Candidate List of the European REACH Regulation No. 1907/2006. See Reach list HTS.



บริษัท เอดีดี เฟอร์เนส จำกัด

ADD FURNACE CO.,LTD.

44 ซอยบรมราชชนนี 70 ถนนบรมราชชนนี แขวงศาลาธรรมสพน์ เขตทวีวัฒนา กรุงเทพฯ 10170

โทร: 02-888-3472 โทร: ออกแบบ:08-08-170-170 แฟกซ์: 02-888-3258

https://www.add-furnace.com E-mail: sales@add-furnace.com

8.2 Burner block

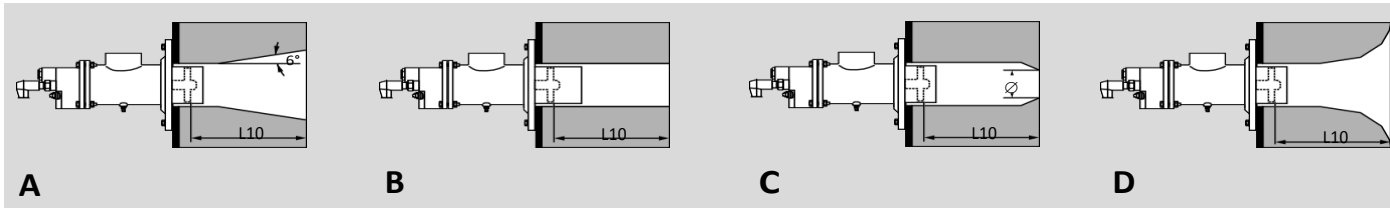

Burner	Rated capacity ¹⁾		Burner block type ²⁾	Burner head code letter	Flame length ³⁾		Flame outlet velocity ⁴⁾	
	kW	10 ³ BTU/h			cm	inch	m/s	ft/s
BIO 50	40	151	A	R	25	9.84	15	49.2
BIO 50	40	151	B	R	30	11.8	55	180
BIO 50	40	151	B	H	50	19.7	50	164
BIO 50	40	151	D	K	–	–	–	–
BIO(A) 65	90	340	A	R	40	15.7	20	65.6
BIO(A) 65	90	340	B	R	50	19.7	70	230
BIO(A) 65	90	340	B	H	60	23.6	65	213
BIO(A) 65	90	340	D	K	–	–	–	–
BIO 80	150	567	A	R	45	17.7	20	65.6
BIO 80	150	567	B	R	60	23.6	75	246
BIO 80	150	567	B	H	70	27.6	70	230
BIO 80	150	567	D	K	–	–	–	–
BIO 100	230	870	A	R	55	21.7	20	65.6
BIO 100	230	870	B	R	70	27.6	75	246
BIO 100	230	870	B	H	80	31.5	70	230
BIO 100	230	870	D	K	–	–	–	–
BIO 125	320	1210	A	R	60	23.6	20	65.6
BIO 125	320	1210	B	R	100	39.4	65	213
BIO 125	320	1210	B	H	115	45.3	60	197
BIO 125	320	1210	D	K	–	–	–	–
BIO 140	450	1702	A	R	80	31.5	20	65.5



บริษัท เอดีดี เฟอร์เนส จำกัด

ADD FURNACE CO.,LTD.

44 ซอยบรมราชชนนี 70 ถนนบรมราชชนนี แขวงศาลาธรรมสพน์ เขตทวีวัฒนา กรุงเทพฯ 10170

โทร: 02-888-3472 โทร: ออกแบบ:08-08-170-170 แฟกซ์: 02-888-3258

<https://www.add-furnace.com> E-mail: sales@add-furnace.com

Burner	Rated capacity ¹⁾		Burner block type ²⁾	Burner head code letter	Flame length ³⁾		Flame outlet velocity ⁴⁾	
	kW	10 ³ BTU/h			cm	inch	m/s	ft/s
BIO 140	450	1702	B	R	120	47.2	75	246
BIO 140	450	1702	B	H	140	55.1	70	230
BIO 140	450	1702	D	K	–	–	–	–
ZIO 165	630	2382	A	R	90	35.4	20	65.6
ZIO 165	630	2382	B	R	110	43.3	75	246
ZIO 165	630	2382	B	H	160	63	70	230
ZIO 165	630	2382	D	K	–	–	–	–
ZIO 200	1000	3782	A	R	100	39.4	25	82
ZIO 200	1000	3782	B	R	130	51.2	85	279
ZIO 200	1000	3782	B	H	200	78.7	80	262
ZIO 200	1000	3782	D	K	–	–	–	–

1) Rated capacity for cold air.

Capacities in kW refer to the lower heating value H_u and capacities in BTU/h refer to the higher heating value H_o (gross calorific value)

2) Data for burner block type C can be found in TI BIC (depending on the selected outlet diameter), Technical Information BIC, BICA, BICW, ZIC, ZICW.

3) Measured from the front edge of the burner block. The flame diameter is approx. one to two times that of the burner tube or burner block outlet.

4) Based on the rated capacity for cold air, with a flame temperature of 1600°C for R burner head and 1500°C for H burner head. The flow velocity is increased when the outlet diameter of the burner block is reduced.



บริษัท เอดีดี เฟอร์เนส จำกัด

ADD FURNACE CO.,LTD.

44 ซอยบรมราชชนนี 70 ถนนบรมราชชนนี แขวงศาลาธรรมสพน์ เขตทวีวัฒนา กรุงเทพฯ 10170

โทร: 02-888-3472 โทร: ออกแบบ:08-08-170-170 แฟกซ์: 02-888-3258

https://www.add-furnace.com E-mail: sales@add-furnace.com

8.3 Dimensions

8.3.1 BIO [mm]

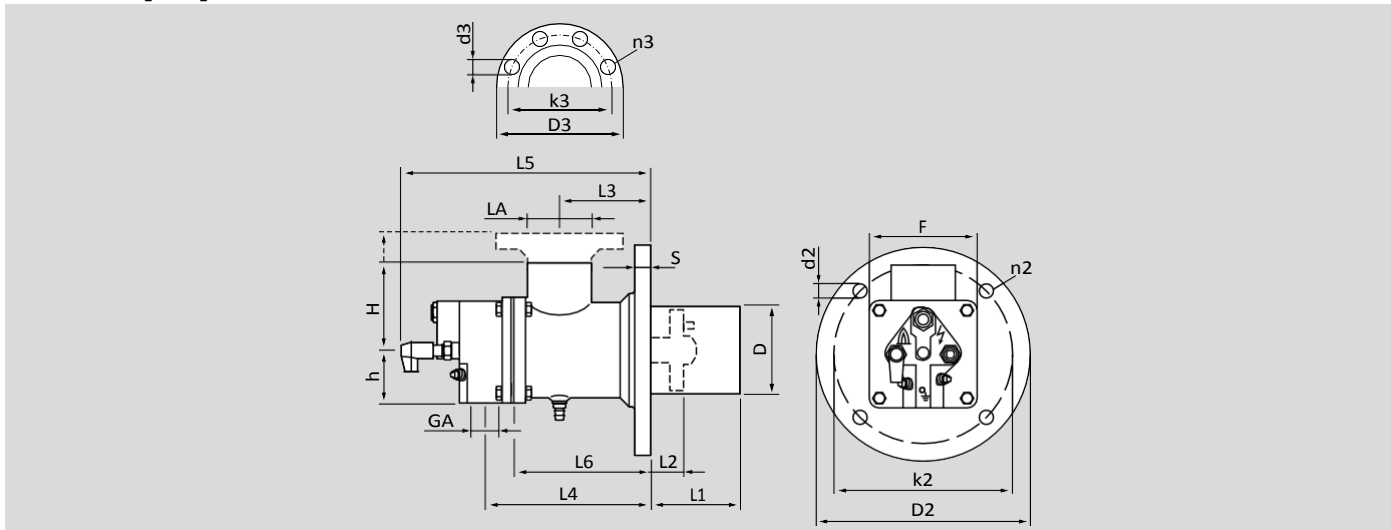

L1 (burner tube length) and L2 (position of burner head) are variable (see web app [BIO/ZIO burner length in burner block](#))

Burner	Connections		Gas connection											Air connection			No. of drillings		Weight [kg]	
	GA	LA	D*	H	h	S	L3	L4	L5	L6	D2	k2	d2	F	D3	k3	d3	n2		n3
BIO 50	Rp ½	Rp 1½	50	50	38	12	73	149	240	127	181	151	12	75	-	-	-	4	-	5.4
BIO 65	Rp ¾	Rp 1½	65	62	48	12	73	156	246	127	195	165	12	95	-	-	-	4	-	7.2
BIO 80	Rp ¾	Rp 2	82	112	55	14	90	172	272	140	240	210	14	110	-	-	-	4	-	11.2
BIO 100	Rp 1	Rp 2	100	100	60	16	103	185	285	153	240	200	14	120	-	-	-	4	-	12.6
BIO 125	Rp 1½	DN 65	127	135	73	16	120	254	350	212	270	240	14	145	185	145	18	4	4	21.7
BIO 140	Rp 1½	DN 80	140	150	80	18	130	271	381	232	300	265	14	160	200	160	18	4	8	29

* Approx. 10 cm larger in the case of a deviation from the standard length, as a weld seam is applied.



8.3.2 BIO [inch]

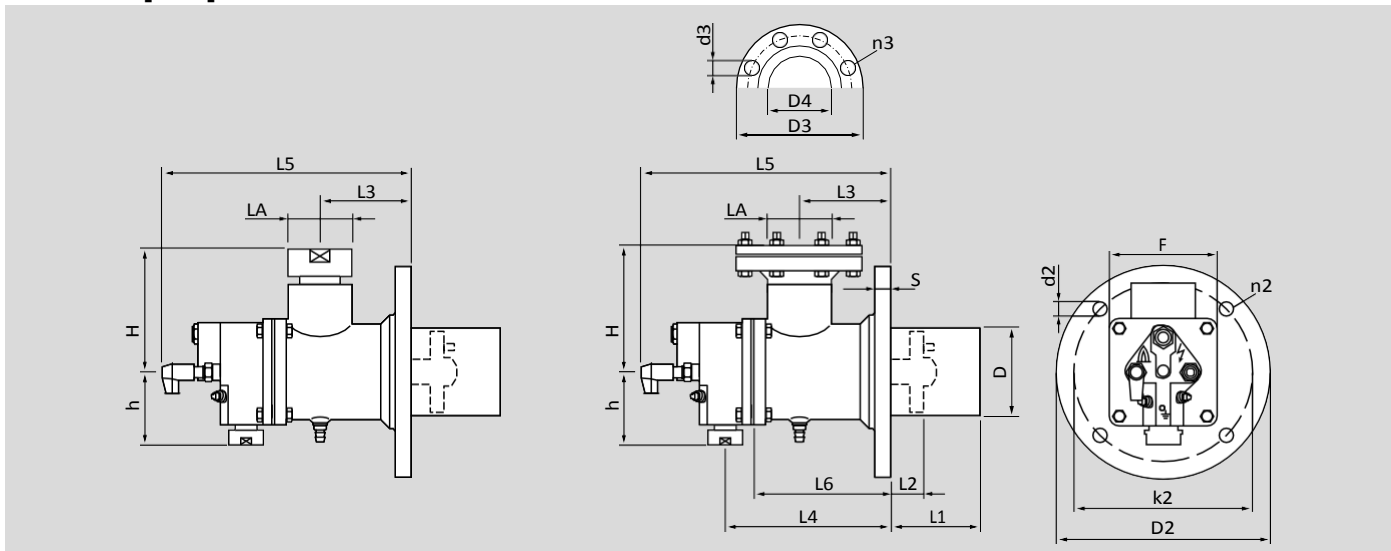

L1 (burner tube length) and L2 (position of burner head) are variable (see web app [BIO/ZIO burner length in burner block](#))

Burner	Connections		Gas connection											Air connection			No. of drillings	Weight [lbs]		
	GA	LA	D*	H	h	S	L3	L4	L5	L6	D2	k2	d2	F	D3	D4			d3	n2
BIO 50	½ NPT	1½ NPT	1.97	1.97	1.5	0.472	2.87	5.87	9.45	5	7.13	5.94	0.47	2.95	-	-	-	4	-	11.9
BIO 65	¾ NPT	1½ NPT	2.56	2.44	1.89	0.472	2.87	6.14	9.69	5	7.68	6.5	0.47	3.74	-	-	-	4	-	15.8
BIO 80	¾ NPT	2 NPT	3.23	4.41	2.17	0.551	3.54	6.77	10.7	5.51	9.45	8.27	0.55	4.33	-	-	-	4	-	24.6
BIO 100	1 NPT	2 NPT	3.94	3.94	2.36	0.63	4.06	7.28	11.2	6.02	9.45	7.87	0.55	4.72	-	-	-	4	-	27.7
BIO 125	1½ NPT	DN 65	5	5.31	2.87	0.63	4.72	10	13.8	8.35	10.6	9.45	0.55	5.71	7.28	2.94	0.709	4	4	47.7
BIO 140	1½ NPT	DN 80	5.51	5.91	3.15	0.709	5.12	10.7	15	9.13	11.8	10.4	0.55	6.3	7.87	3.57	0.709	4	8	63.8

* Approx. 0.39" larger in the case of a deviation from the standard length, as a weld seam is applied.



บริษัท เอดีดี เฟอร์เนส จำกัด

ADD FURNACE CO.,LTD.

44 ซอยบรมราชชนนี 70 ถนนบรมราชชนนี แขวงศาลาธรรมสพน์ เขตทวีวัฒนา กรุงเทพฯ 10170

โทร: 02-888-3472 โทร: ออกแบบ:08-08-170-170 แฟกซ์: 02-888-3258

https://www.add-furnace.com E-mail: sales@add-furnace.com

8.3.3 BIOA [mm]

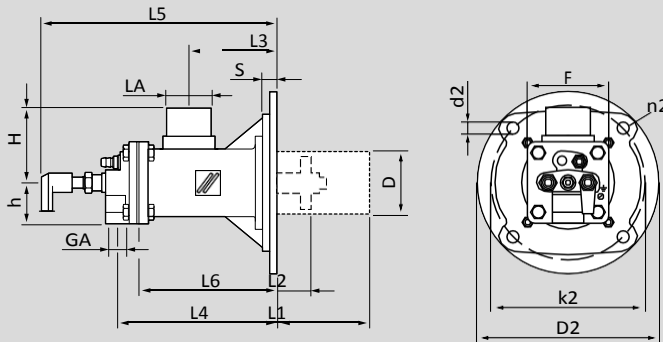

Burner	Connections		Gas connection										Air connection			No. of drillings		Weight [kg]		
	GA	LA	D*	H	h	S	L3	L4	L5	L6	D2	k2	d2	F	D3	k3	d3		n2	n3
BIOA 65	Rp 1/2	Ø 48	65	110	44	16	95	170	261	149	195	165	13	88	-	-	-	4	-	3.6

* Approx. 10 cm larger in the case of a deviation from the standard length, as a weld seam is applied.



บริษัท เอดีดี เฟอร์เนส จำกัด

ADD FURNACE CO.,LTD.

44 ซอยบรมราชชนนี 70 ถนนบรมราชชนนี แขวงศาลาธรรมสพน์ เขตทวีวัฒนา กรุงเทพฯ 10170

โทร: 02-888-3472 โทร: ออกแบบ:08-08-170-170 แฟกซ์: 02-888-3258

https://www.add-furnace.com E-mail: sales@add-furnace.com

8.3.4 BIOA [inch]

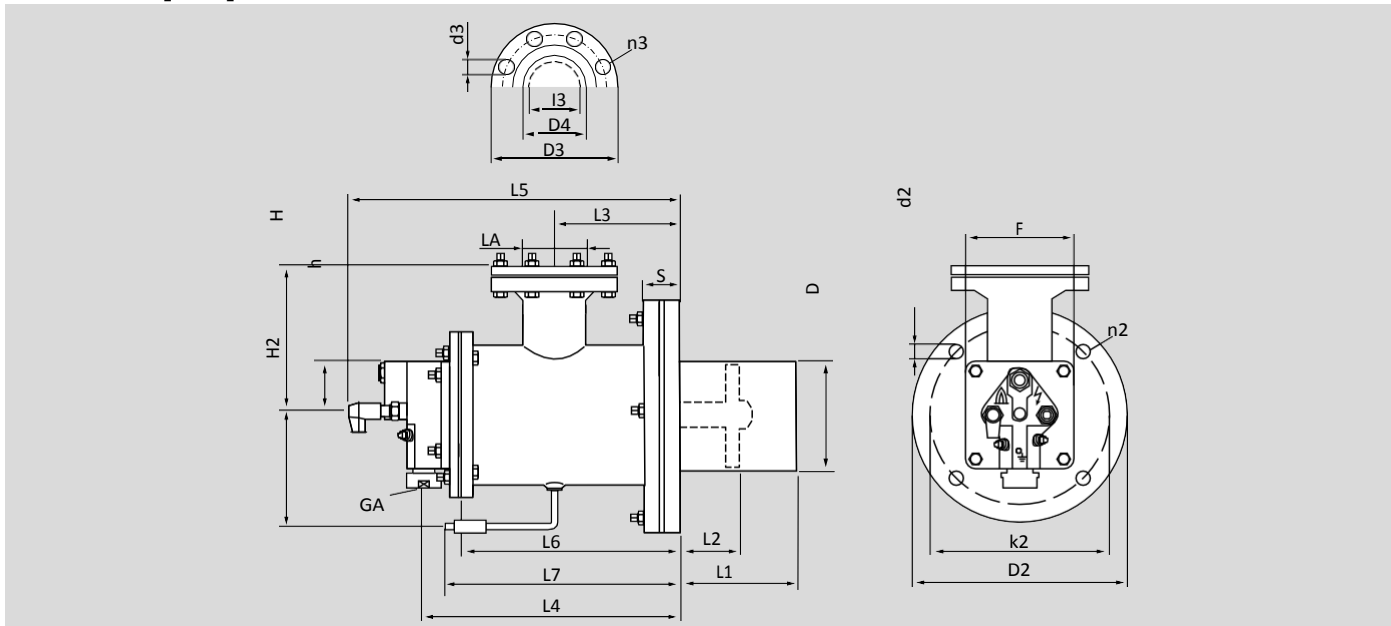

Burner	Connections		Gas connection										Air connection			No. of drillings		Weight [kg]		
	GA	LA	D*	H	h	S	L3	L4	L5	L6	D2	k2	d2	F	D3	k3	d3		n2	n3
BIOA 65	½ NPT	Ø 48	65	110	44	16	95	170	261	149	195	165	13	88	-	-	-	4	-	3.6

* Approx. 0.39" larger in the case of a deviation from the standard length, as a weld seam is applied.



บริษัท เอดีดี เฟอร์เนส จำกัด

ADD FURNACE CO.,LTD.

44 ซอยบรมราชชนนี 70 ถนนบรมราชชนนี แขวงศาลาธรรมสพน์ เขตทวีวัฒนา กรุงเทพฯ 10170

โทร: 02-888-3472 โทร: ออกแบบ:08-08-170-170 แฟกซ์: 02-888-3258

https://www.add-furnace.com E-mail: sales@add-furnace.com

8.3.5 BIOW [mm]

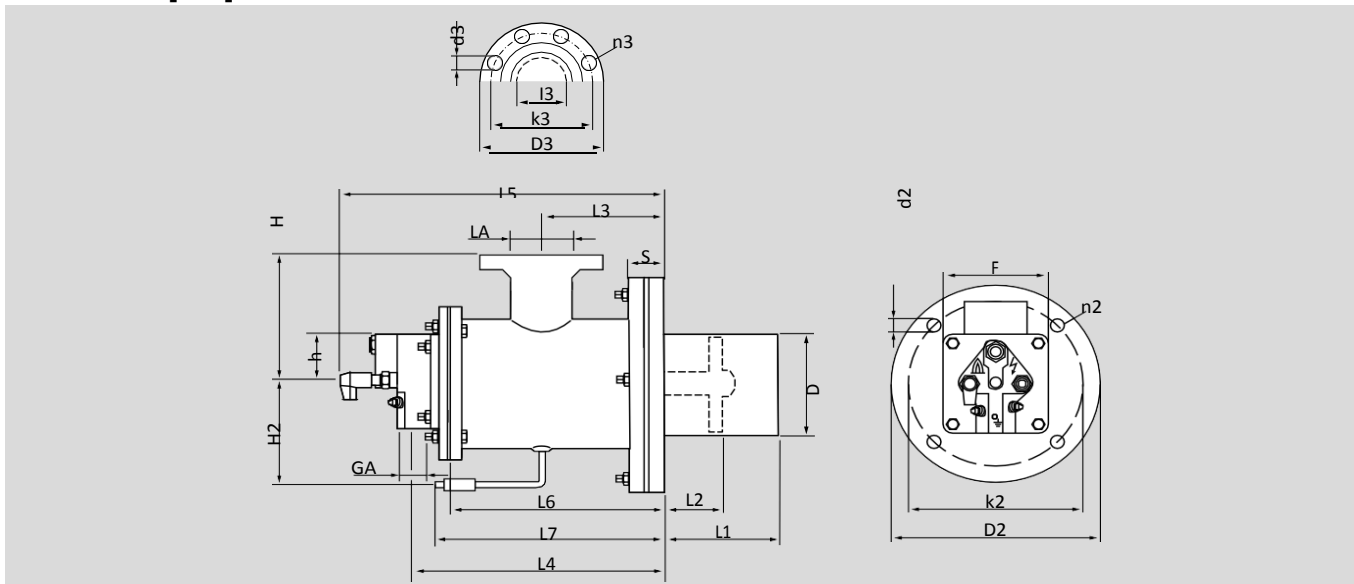

L1 (burner tube length) and L2 (position of burner head) are variable (see web app [BIO/ZIO burner length in burner block](#))

Burner	Connections		Gas connection													Air connection			No. of drillings		Weight [kg]		
	GA	LA	D*	H	H2	h	S	L3	L4	L5	L6	L7	D2	k2	d2	F	D3	k3	d3	I3		n2	n3
BIOW 65	Rp 3/4	DN 65	65	142	93.5	47	22	121.5	256	344	216	283	195	165	12	138	185	145	18	58	4	8	11.2
BIOW 80	Rp 3/4	DN 80	82	152	103	54	22	139	272	368	229	305	240	210	14	156	200	160	18	70	4	8	15.2
BIOW 100	Rp 1	DN 80	100	152	110	59	22	139	285	381	242	305	240	200	14	172	200	160	18	70	4	8	17.1
BIOW 125	Rp 1 1/2	DN 100	127	182	123	72	22	170	351	450	299	331	270	240	14	200	220	180	18	83	4	8	26.2
BIOW 140	Rp 1 1/2	DN 125	140	195	130	79	22	180	371	480	319	341	300	265	14	215	250	210	18	106	4	8	24

* Approx. 10 cm larger in the case of a deviation from the standard length, as a weld seam is applied.



บริษัท เอดีดี เฟอร์เนส จำกัด

ADD FURNACE CO.,LTD.

44 ซอยบรมราชชนนี 70 ถนนบรมราชชนนี แขวงศาลาธรรมสพน์ เขตทวีวัฒนา กรุงเทพฯ 10170

โทร: 02-888-3472 โทร: ออกแบบ:08-08-170-170 แฟกซ์: 02-888-3258

https://www.add-furnace.com E-mail: sales@add-furnace.com

8.3.6 BIOW [inch]

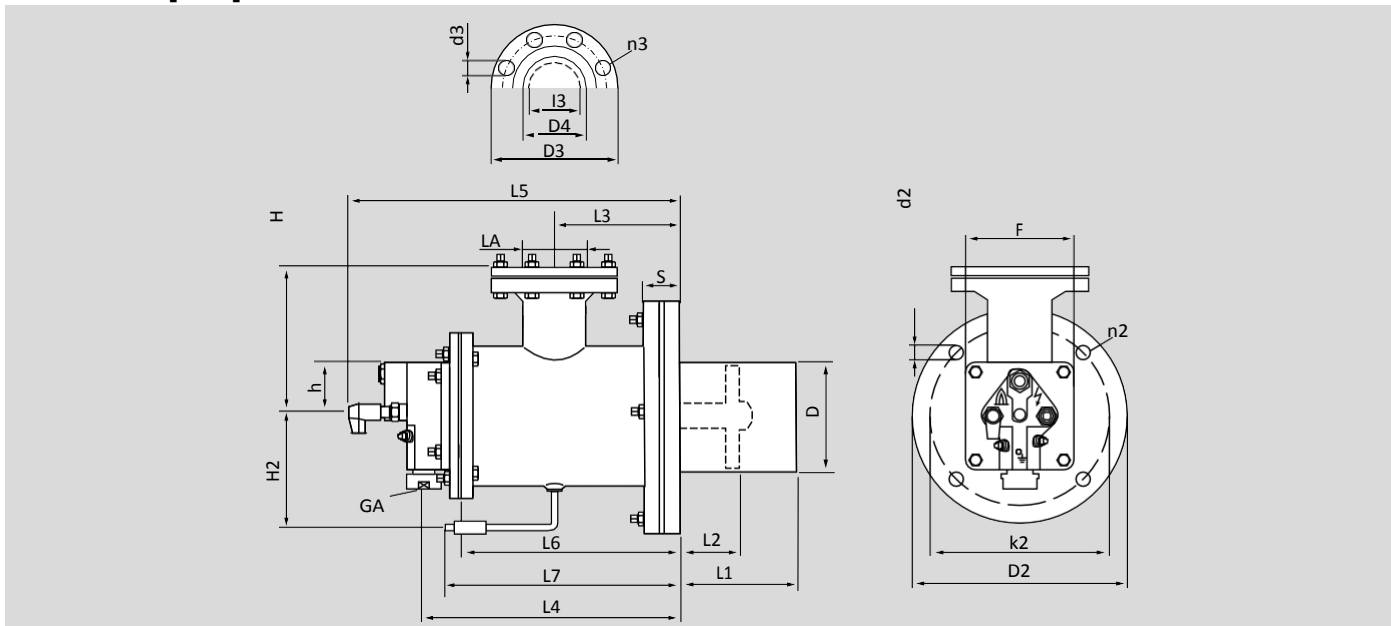

L1 (burner tube length) and L2 (position of burner head) are variable (see web app [BIO/ZIO burner length in burner block](#))

Burner	Connections		Gas connection														Air connection				No . of drillings		Weight [lbs]
	GA	LA	D*	H	H2	h	S	L3	L4	L5	L6	L7	D2	k2	d2	F	D3	D4	d3	I3	n2	n3	
BIOW 65	¼ NPT	DN 65	2.56	5.59	3.68	1.85	0.866	4.78	10.1	13.5	8.5	11.1	7.68	6.5	0.47	5.43	7.28	2.94	0.709	58	4	8	24.6
BIOW 80	¼ NPT	DN 80	3.23	5.98	4.06	2.13	0.866	5.47	10.7	14.5	9.02	12	9.45	8.27	0.55	6.14	7.87	3.57	0.709	70	4	8	33.7
BIOW 100	1 NPT	DN 80	3.94	5.98	4.33	2.32	0.866	5.47	11.2	15	9.53	12	9.45	7.87	0.55	6.77	7.87	3.57	0.709	70	4	8	37.6
BIOW 125	1½ NPT	DN 100	5	7.17	4.84	2.83	0.866	6.69	13.8	17.7	11.8	13	10.6	9.45	0.55	7.87	8.66	4.57	0.709	83	4	8	57.6
BIOW 140	1½ NPT	DN 125	5.51	7.68	5.12	3.11	0.866	7.09	14.6	18.9	12.6	13.4	11.8	10.4	0.55	8.46	9.84	5.65	0.709	106	4	8	52.8

* Approx. 10 cm larger in the case of a deviation from the standard length, as a weld seam is applied.



8.3.7 ZIO [mm]

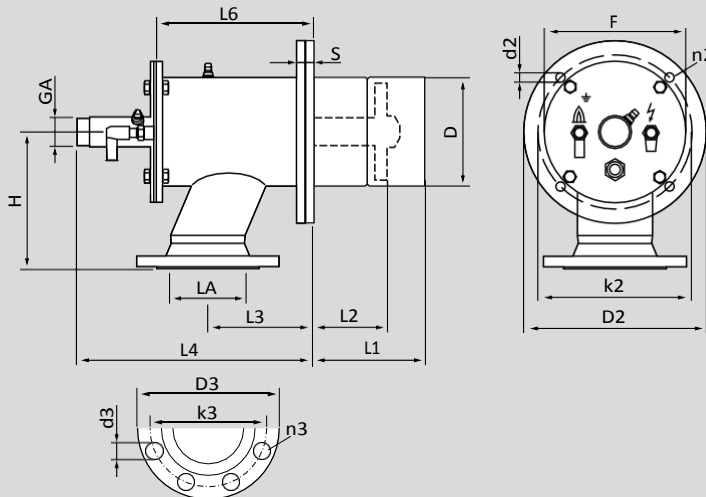

L1 (burner tube length) and L2 (position of burner head) are variable (see web app [BIO/ZIO burner length in burner block](#))

Burner	Connections		Gas connection										Air connection			No. of drillings		Weight [kg]
	GA	LA	D*	H	S	L3	L4	L6	D2	k2	d2	F	D3	k3	d3	n2	n3	
ZIO 165	R 1½	DN 100	165	213	20	150	359	230	285	240	14	220	220	180	18	4	8	26
ZIO 200	R 2	DN 150	194	220	20	220	469	340	330	295	22	255	285	240	22	8	8	37

* Approx. 10 cm larger in the case of a deviation from the standard length, as a weld seam is applied.



บริษัท เอดีดี เฟอร์เนส จำกัด

ADD FURNACE CO.,LTD.

44 ซอยบรมราชชนนี 70 ถนนบรมราชชนนี แขวงศาลาธรรมสพน์ เขตทวีวัฒนา กรุงเทพฯ 10170

โทร: 02-888-3472 โทร: ออกแบบ:08-08-170-170 แฟกซ์: 02-888-3258

https://www.add-furnace.com E-mail: sales@add-furnace.com

8.3.8 ZIO [inch]

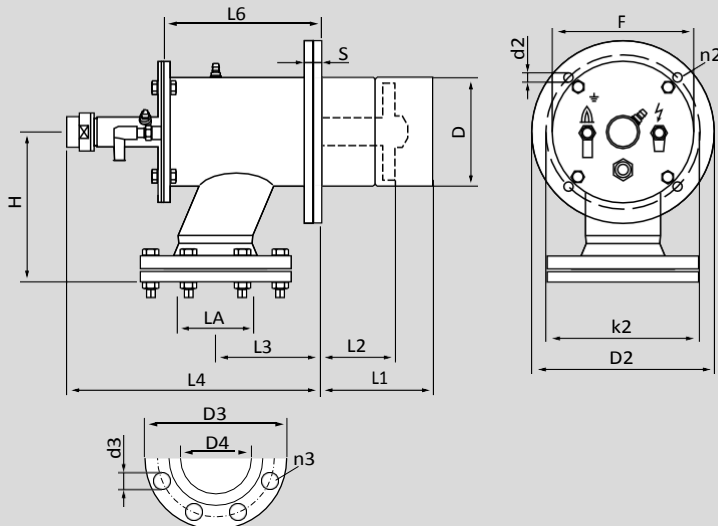

L1 (burner tube length) and L2 (position of burner head) are variable (see web app [BIO/ZIO burner length in burner block](#))

Burner	Connections		Gas connection											Air connection			No. of drillings		Weight [lbs]	
	GA	LA	D*	H	h	S	L3	L4	L5	L6	D2	k2	d2	F	D3	D4	d3	n2		n3
ZIO 165	1½ NPT	DN 100	6.5	8.39	-	0.787	5.91	14.1	-	9.06	11.2	9.45	0.55	8.66	8.66	4.57	0.709	4	8	57.2
ZIO 200	2 NPT	DN 150	7.64	8.66	-	0.787	8.66	18.5	-	13.4	13	11.6	0.87	10	11.2	6.72	0.866	8	8	81.4

* Approx. 10 cm larger in the case of a deviation from the standard length, as a weld seam is applied.



บริษัท เอดีดี เฟอร์เนส จำกัด

ADD FURNACE CO.,LTD.

44 ซอยบรมราชชนนี 70 ถนนบรมราชชนนี แขวงศาลาธรรมสพน์ เขตทวีวัฒนา กรุงเทพฯ 10170

โทร: 02-888-3472 โทร: ออกแบบ:08-08-170-170 แฟกซ์: 02-888-3258

https://www.add-furnace.com E-mail: sales@add-furnace.com

8.3.9 ZIOW [mm]

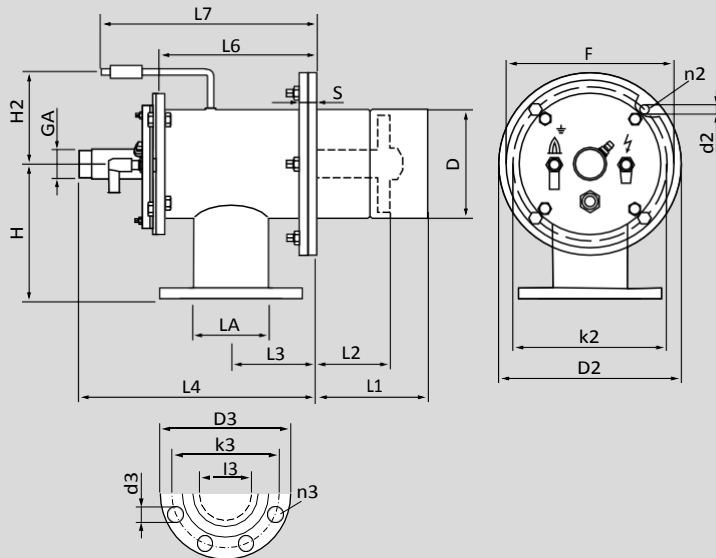

L1 (burner tube length) and L2 (position of burner head) are variable (see web app [BIO/ZIO burner length in burner block](#))

Burner	Connections		Gas connection													Air connection				No. of drillings		Weight [kg]
			GA	LA	D*	H	H2	S	L3	L4	L5	L6	L7	D2	k2	d2	F	D3	k3	d3	l3	
ZIOW 165	R 1½	DN 150	165	213	139	20	187	460	–	320	349	285	240	14	264	285	240	22	130	4	8	32
ZIOW 200	R 2	DN 200	194	217	157	20	256	569	–	427	417	330	295	22	300	340	295	22	160	8	12	

* Approx. 10 cm larger in the case of a deviation from the standard length, as a weld seam is applied.



8.3.10 ZIOW [inch]

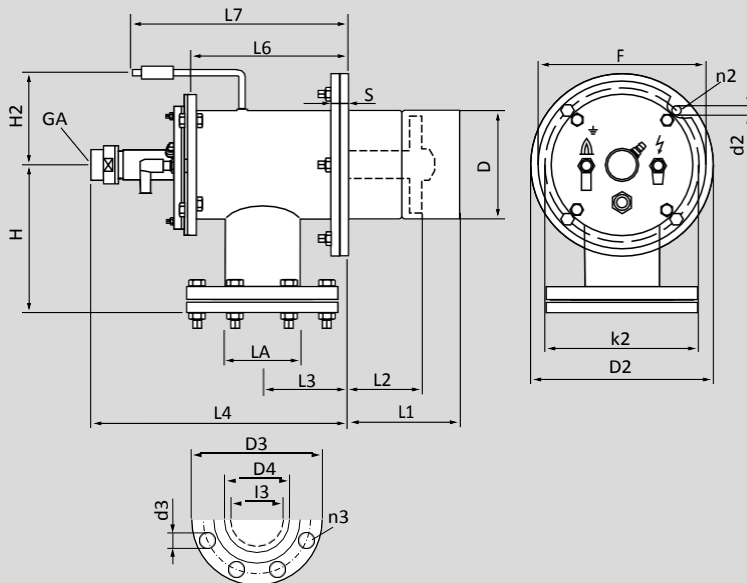

L1 (burner tube length) and L2 (position of burner head) are variable (see web app [BIO/ZIO burner length in burner block](#))

Burner	Connections		Gas connection										Air connection				No . of drillings		Weight [lbs]		
	GA	LA	D*	H	H2	S	L3	L4	L6	L7	D2	k2	d2	F	D3	D4	d3	l3		n2	n3
ZIOW 165	1½ NPT	DN 150	6.89	8.39	5.5	0.79	7.36	18.1	12.6	13.7	11.2	9.45	0.55	10.4	11.2	4.57	0.866	5.12	4	8	70.4
ZIOW 200	2 NPT	DN 200	7.6	8.5	6.2	0.79	10.1	22.4	16.8	16.4	13	11.6	0.87	11.8	13.4	6.72	0.866	6.3	8	12	

* Approx. 10 cm larger in the case of a deviation from the standard length, as a weld seam is applied.



บริษัท เอดีดี เฟอร์เนส จำกัด

ADD FURNACE CO.,LTD.

44 ซอยบรมราชชนนี 70 ถนนบรมราชชนนี แขวงศาลาธรรมสพน์ เขตทวีวัฒนา กรุงเทพฯ 10170

โทร: 02-888-3472 โทร: ออกแบบ:08-08-170-170 แฟกซ์: 02-888-3258

<https://www.add-furnace.com> E-mail: sales@add-furnace.com

8.3.11 Torch BIO/BIOW

Gas connection: Rp ¼ (NPT ¼ – see page 35 (Integrated torch connections)). Air

connection: Rp 3/8 (NPT 3/8 – see page 35 (Integrated torch connections)). Gas

pressure: 30–50mbar (11.8–19.7"WC).

Air pressure: 30–50 mbar (11.8–19.7 "WC).

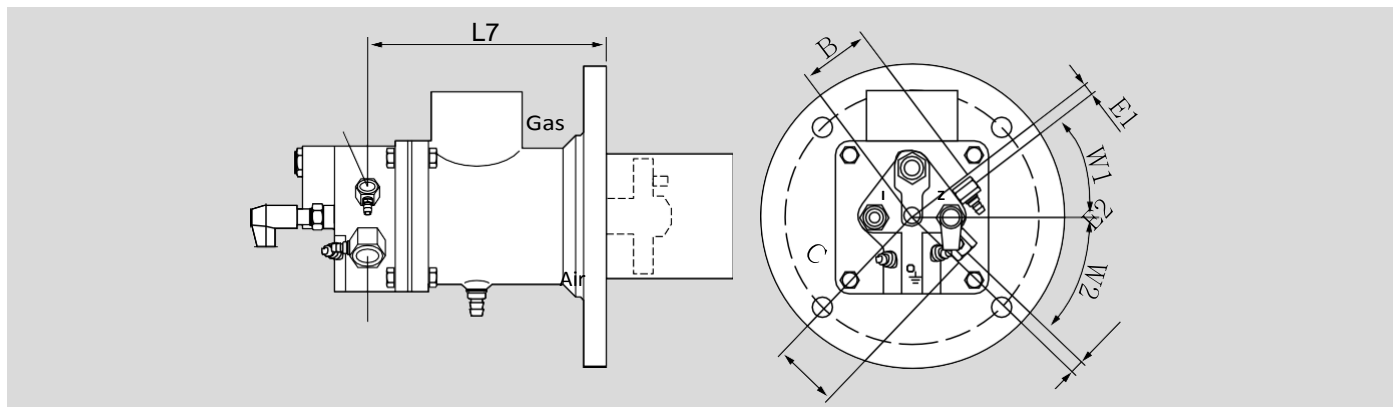

Burner	Gas connection		Air connection		Dimensions							
	B		C		E1		E2		L7		W1	W2
	mm	inch	mm	inch	mm	inch	mm	inch	mm	inch	°	°
BIO 65..L	101	3.98	61	2.4	20	0.787	47	1.85	158	6.22	29	61
BIO 80..L	57	2.24	54	2.13	7	0.276	10	0.394	177	6.97	36	45
BIO 100..L	57	2.24	54	2.13	7	0.276	10	0.394	190	7.48	36	45
BIO 125..L	69	2.72	65	2.56	8	0.315	8	0.315	249	10.3	30	30
BIO 140..L	63	2.48	62	2.44	16	0.63	18	0.709	276	10.9	42	45
BIOW 65..L	101	9.98	61	2.42	20	0.787	47	1.85	247	9.72	29	61
BIOW 80..L	57	2.24	54	2.13	7	0.276	10	0.394	266	10.5	36	45
BIOW 100..L	57	2.24	54	2.13	7	0.276	10	0.394	279	11	36	45
BIOW 125..L	69	2.72	65	2.56	8	0.315	8	0.315	348	13.7	30	30
BIOW 140..L	63	2.48	62	2.44	16	0.63	18	0.709	363	14.3	42	45



บริษัท เอดีดี เฟอร์เนส จำกัด

ADD FURNACE CO.,LTD.

44 ซอยบรมราชชนนี 70 ถนนบรมราชชนนี แขวงศาลาธรรมสพน์ เขตทวีวัฒนา กรุงเทพฯ 10170

โทร: 02-888-3472 โทร: ออกแบบ:08-08-170-170 แฟกซ์: 02-888-3258

https://www.add-furnace.com E-mail: sales@add-furnace.com

8.3.12 Torch ZIO/ZIOW

Gas connection: Rp ¼ (NPT ¼). Air

connection: Rp ½ (NPT ½).

Gas pressure: 30–50 mbar (11.8–19.7 "WC).

Air pressure: 30–50 mbar (11.8–19.7 "WC).

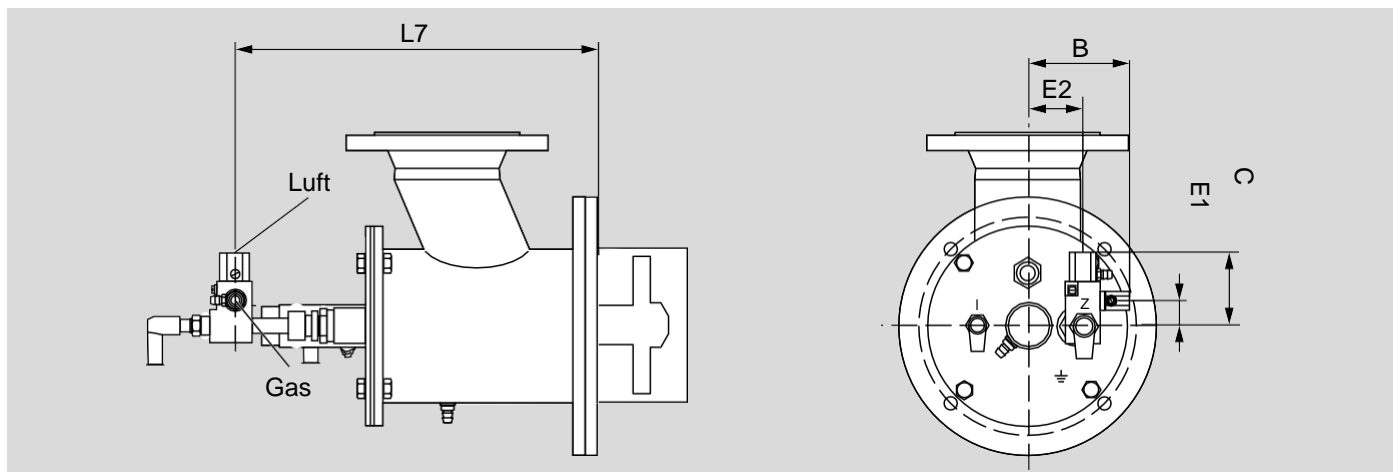

Burner	Gas connection		Air connection		Dimensions					
	B		C		E1		E2		L7	
	mm	inch	mm	inch	mm	inch	mm	inch	mm	inch
ZIO 165..L	118	4.65	77	3.03	27	1.06	71	2.8	382	15
ZIO 200..L	137	5.39	77	3.03	27	1.06	89	3.5	482	19
ZIOW 165..L	118	4.65	77	3.03	27	1.06	71	2.8	472	18.6
ZIOW 200..L	137	5.39	77	3.03	27	1.06	89	3.5	569	22.4



บริษัท เอดีดี เฟอร์เนส จำกัด

ADD FURNACE CO.,LTD.

44 ซอยบรมราชชนนี 70 ถนนบรมราชชนนี แขวงศาลาธรรมสพน์ เขตทวีวัฒนา กรุงเทพฯ 10170

โทร: 02-888-3472 โทร: ออกแบบ:08-08-170-170 แฟกซ์: 02-888-3258

<https://www.add-furnace.com> E-mail: sales@add-furnace.com

8.3.13 Electrodes with air connection BIO/BIOW

Air connection: Rp ¼ (NPT ¼)

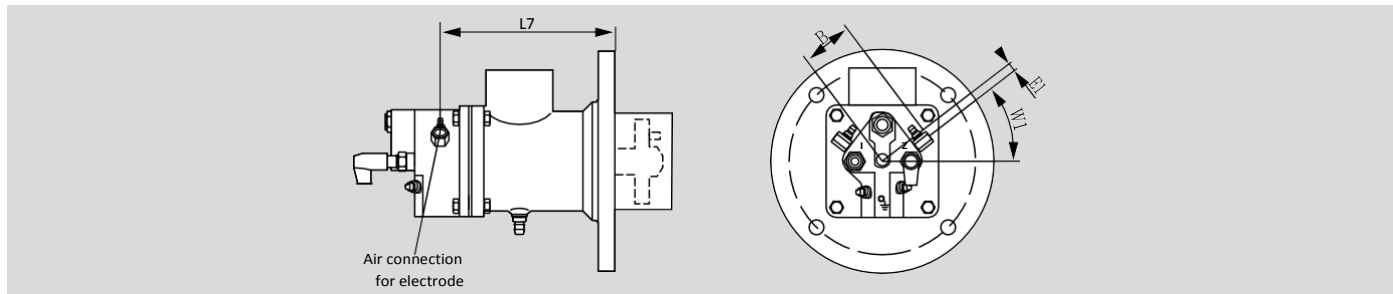

Burner	Dimensions						
	B		E1		L7		W1
	mm	inch	mm	inch	mm	inch	°
BIO 80	57	2.24	7	0.276	177	6.97	36
BIO 100	57	2.24	7	0.276	190	7.48	36
BIO 125	69	2.72	8	0.315	249	10.3	30
BIO 140	63	2.48	16	0.63	276	10.9	42
BIOW 80	57	2.24	7	0.276	277	10.9	36
BIOW 100	57	2.24	7	0.276	290	11.4	36
BIOW 125	69	2.72	8	0.315	361	14.2	30
BIOW 140	63	2.48	16	0.63	376	14.8	42



บริษัท เอดีดี เฟอร์เนส จำกัด

ADD FURNACE CO.,LTD.

44 ซอยบรมราชชนนี 70 ถนนบรมราชชนนี แขวงศาลาธรรมสพน์ เขตทวีวัฒนา กรุงเทพฯ 10170

โทร: 02-888-3472 โทร: ออกแบบ:08-08-170-170 แฟกซ์: 02-888-3258

<https://www.add-furnace.com> E-mail: sales@add-furnace.com

8.3.14 Electrodes with air connection ZIO/ZIOW

Air connection: Rp ¼ (NPT ¼)

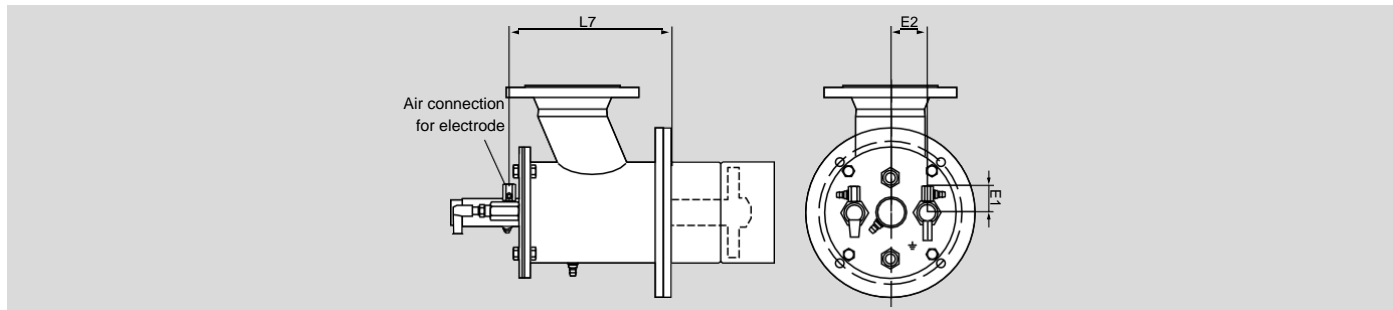

Burner	Dimensions					
	L7		E1		E2	
	mm	inch	mm	inch	mm	inch
ZIO 165	259	10.2	45.5	1.79	49	1.93
ZIO 200	369	14.5	45.5	1.79	55	2.17
ZIOW 165	349	13.7	45.5	1.79	49	1.93
ZIOW 200	456	18	45.5	1.79	55	2.17



บริษัท เอดีดี เฟอร์เนส จำกัด

ADD FURNACE CO.,LTD.

44 ซอยบรมราชชนนี 70 ถนนบรมราชชนนี แขวงศาลาธรรมสพน์ เขตทวีวัฒนา กรุงเทพฯ 10170

โทร: 02-888-3472 โทร: ออกแบบ:08-08-170-170 แฟกซ์: 02-888-3258

<https://www.add-furnace.com> E-mail: sales@add-furnace.com

9 Maintenance cycles

Twice per year, but if the media are highly contaminated, this interval should be reduced.



บริษัท เอดีดี เฟอร์เนส จำกัด

ADD FURNACE CO.,LTD.

44 ซอยบรมราชชนนี 70 ถนนบรมราชชนนี แขวงศาลาธรรมสพน์ เขตทวีวัฒนา กรุงเทพฯ 10170

โทร: 02-888-3472 โทร: ออกแบบ:08-08-170-170 แฟกซ์: 02-888-3258

<https://www.add-furnace.com> E-mail: sales@add-furnace.com

10 Legend

10.1 Legend (mechanical)

	Manual valve
	Gas solenoid valve
	Air/gas ratio control with solenoid valve
	Flow adjusting cock
	Butterfly valve with actuator
	Butterfly valve with manual adjustment
	Gas solenoid valve, slow opening
	Air/gas ratio control with bypass nozzle