

Honeywell

**krom
schroder**

Solenoid valves for gas VAS, double solenoid valves VCS

TECHNICAL INFORMATION

- Suitable for a max. inlet pressure of 500 mbar (7 psig)
- Easy installation into a system
- Compact design saves space
- No extra valve required owing to integrated flow adjustment
- Check indication by blue LED
- Proof of closure switch with integrated visual position indicator
- Suitable for high-duty cycling



Contents

Contents	2
1 Application	4
1.1 Configuring solenoid valves for gas VAS 1–3 or double solenoid valves VCS 1–3.....	6
1.2 Application examples for VAS 1–3, VCS 1–3	7
1.3 Configuring solenoid valves for gas VAS 6–9 or double solenoid valves VCS 6–9 (Basic).....	8
1.4 Configuring solenoid valves for gas VAS 6–9 or double solenoid valves VCS 6–9 with adapter plate connection (Extended)	9
1.5 Application examples for VAS 6–9, VCS 6–9.....	10
2 Certification	11
3 Function	12
3.1 Solenoid valve for gas VAS..N, quick opening.....	13
3.2 Solenoid valve for gas VAS..L, slow-opening.....	14
3.3 Solenoid valve for gas VAS..S/VAS..G, proof of closure switch with visual position indicator.....	15
3.4 Connection diagram	16
3.4.1 VAS with M20 cable gland.....	16
3.4.2 VAS with plug.....	16
3.4.3 VAS..S/VAS..G, proof of closure switch with visual position indicator	16
3.4.4 VCS with M20 cable gland.....	16
3.4.5 VCS with plug	17
4 Flow rate	18
4.1 Calculating the nominal size	18
4.2 VAS	19
4.3 VCS	21
5 Selection	23
5.1 ProFi.....	23
5.2 Selection table for VAS 1–3	23
5.3 Selection table for VAS 6–9	25
5.4 Typenschlüssel VAS 1–9.....	27

Selection table for VCS 1–3	28
5.6 Selection table for VCS 6–9.....	30
5.7 Typenschlüssel VCS 1–9	32
6 Project planning information	33
6.1 Connections p_u , p_d , p_z	33
6.2 Installation	33
6.3 Design specifications	34
6.4 Note on settings	34
6.5 Opening times	34
6.6 Flow rate for bypass or pilot gas valve	34
6.7 Tightness control TC 1V.....	35
6.8 Electrical connection.....	35
7 Accessories	36
7.1 Pressure switch for gas DG..C.....	36
7.1.1 Installation on VCS 1–3	37
7.1.2 DG..C fastening set for VAX 1–3	37
7.1.3 Installation on VAS 6–9	37
7.1.4 Installation on VCS 6–9.....	37
7.2 Bypass/pilot gas valve VAS 1.....	38
7.2.1 Flow rate, VAS 1 attached to VAS 1, VAS 2, VAS 3	38
7.2.2 Scope of delivery of VAS 1 for VAS 1, VAS 2, VAS 3	39
7.2.3 Flow rate, VAS 1 attached to VAS 6–9, VCS 6–9	40
7.2.4 Scope of delivery of VAS 1 for VAS 6–9, VCS 6–9	41
7.3 Bypass/pilot gas valve VBY 8.....	42
7.3.1 Flow rate, VBY.....	42
7.3.2 Scope of delivery of VBY for VAS 1.....	43
7.3.3 Type code	43
7.4 Pressure test nipples	44
7.5 Cable gland set.....	44
7.6 Attachment block VAS 1–3.....	44
7.7 Seal set for sizes 1–3	45
7.8 Adapter plates for VAS/VCS 6–9.....	45
7.8.1 Bypass adapter	45
7.8.2 Measuring adapter.....	46

7.8.3	Relief line adapter	46
7.9	Cable gland with pressure equalization element	46
7.10	Measuring orifice VMO	47
7.11	Filter module VMF	47
7.12	Fine-adjusting valve VMV	47
7.13	Tightness control TC 1V	48
7.13.1	Type code	48
7.14	Valve connection cable	48
7.15	Adapter for length compensation VAS 6–9	49
8	Technical data	50
8.1	Ambient conditions	50
8.2	Mechanical data	50
8.3	Electrical data for VAS1–3/VCS 1–3	51
8.4	Electrical data for VAS6–9/VCS 6–9	51
9	Dimensions	53
9.1	VAS 1–3 with Rp internal thread [mm]	53
9.2	VAS 2–9 with ISO flange [mm]	54
9.3	VCS 1–3 with Rp internal thread [mm]	55
9.4	VCS 2–9 with ISO flange [mm]	56
9.5	VAS 1–3..T with NPT internal thread [inch]	57
9.6	VAS 6–9..T with ANSI flange [inch]	58
9.7	VCS 1–3..T with NPT internal thread [inch]	59
9.8	VCS 6–9..T with ANSI flange [inch]	60
10	Converting units	61
	Safety-specific characteristic values for SIL and PL	62
11.1	Determining the PFH _D value, λ _D value and MTTF _d value	62
11.2	Designed lifetime	63
11.3	Use in safety-related systems	63
12	Safety information in accordance with EN 61508-2	64
12.1	Scope of application	64

Product description	64
12.3 Reference documents	64
12.4 Applicable standards	64
12.5 Safety function	64
12.6 Safety instructions concerning operating limits	64
12.7 Installation and commissioning	64
12.8 Maintenance/Checks	64
12.9 Troubleshooting	64
12.10 Safety instructions concerning design verification	64
12.11 Characteristic safety data/SIL capability	65
12.12 Mode of operation	65
13 Maintenance cycles	66
14 Glossary	67
14.1 Diagnostic coverage DC	67
14.2 Mode of operation	67
14.3 Category	67
14.4 Common cause failure CCF	67
14.5 Fraction of undetected common cause failures β ..	67 14.6
B _{10d} value	67
14.7 T _{10d} value	67
14.8 Hardware fault tolerance HFT	67
14.9 Mean dangerous failure rate λ _D	68
14.10 Safe failure fraction SFF	68
14.11 Probability of dangerous failure PFH _D	68
14.12 Mean time to dangerous failure MTTF _d	68
14.13 Demand rate n _{op}	68
14.14 Average probability of dangerous failure on demand PFD _{avg}	68
Fore more information	69

1 Application

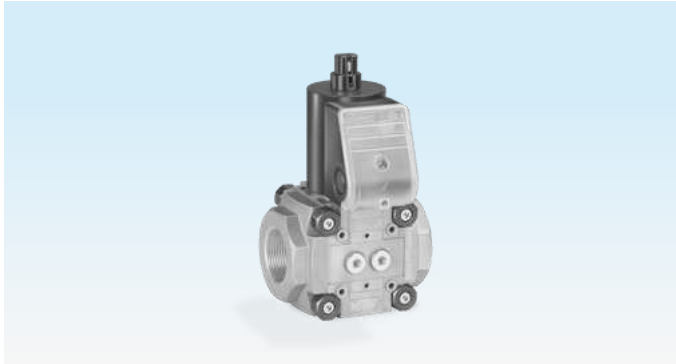

VAS..R, quick opening



VAS..F, quick opening



VCS..R with damping unit

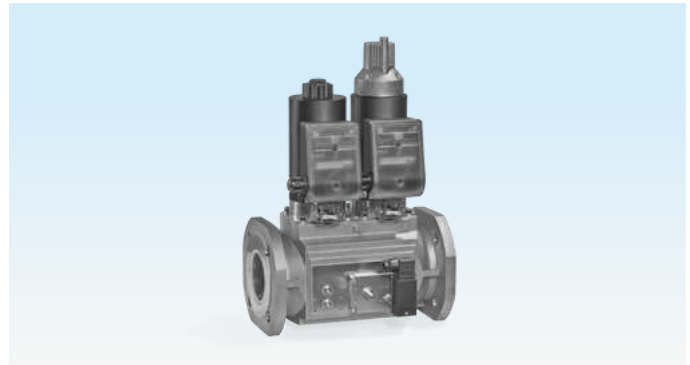

VCS..F with proof of closure switch and pressure switch

The modular design principle allows the individual components of the VAS, VCS Series to be easily assembled: e.g. quick opening, slow opening, with proof of closure switch and visual position indicator, slow opening with attached pressure switch.

Solenoid valves for gas VAS and double solenoid valves VCS for safeguarding and controlling the air and gas supply to gas burners and gas appliances. For use in gas control and safety systems in all sectors of the iron, steel, glass and ceramics industries, as well as in commercial heat generation, such as the packaging, paper and foodstuffs industries.



Ceramics industry



Aluminium industry: curing oven for wheel rims



Foodstuffs industry: baking oven

1.1 Configuring solenoid valves for gas VAS 1–3 or double solenoid valves VCS 1–3

Threaded flange for pipe connections (Rp or NPT) from DN 10 to 65, flanged connection (ISO or ANSI) for sizes 2 and 3 for pipe connections DN 40 and 50.

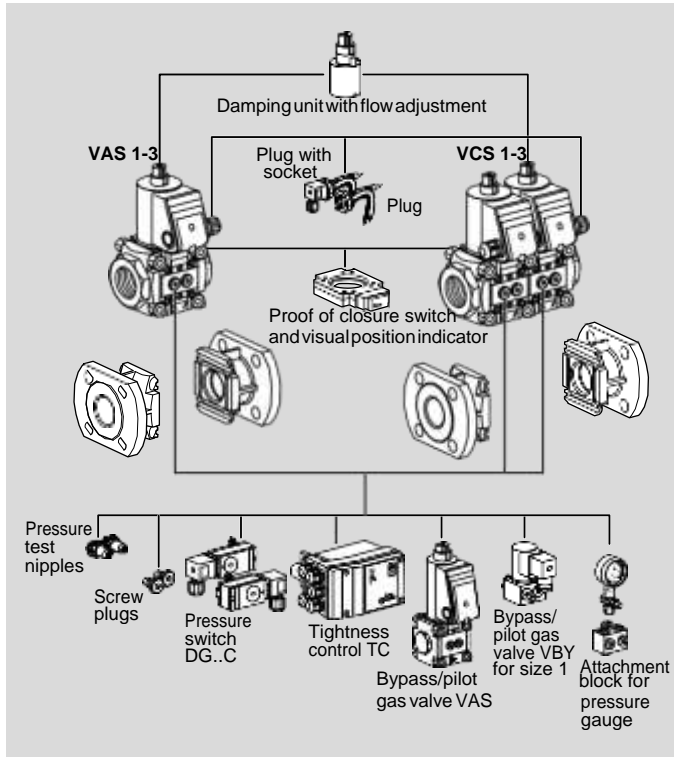

Modularly configurable with:

- Damping unit
- Proof of closure switch
- Plug (with or without socket)
- Pressure test nipples
- Screw plugs
- Pressure switch DG..C for inlet and/or outlet pressure
- Tightness control TC
- Bypass/pilot gas valve
- Attachment block for the connection of a pressure gauge, for example

1.2 Application examples for VAS 1–3, VCS 1–3

Gas solenoid valve with inlet and outlet pressure switch

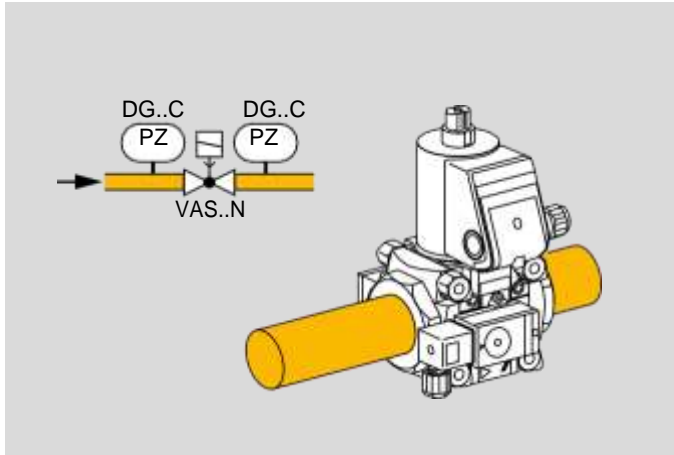

VAS..N, quick opening, pressure switch DG..C for inlet pressure p_u and outlet pressure p_d

Double solenoid valve VCS with damping unit VCS..NL

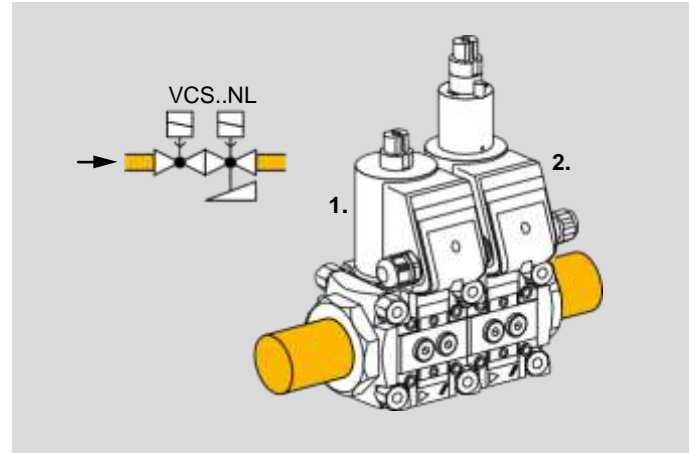

*1st valve quick opening, quick closing, with flow adjustment
 2nd valve slow opening, quick closing*

1.3 Configuring solenoid valves for gas VAS 6–9 or double solenoid valves VCS 6–9 (Basic)

Gas solenoid valve and double solenoid valve with flanged connection (ISO or ANSI) for pipe connections from DN 65 to 125.

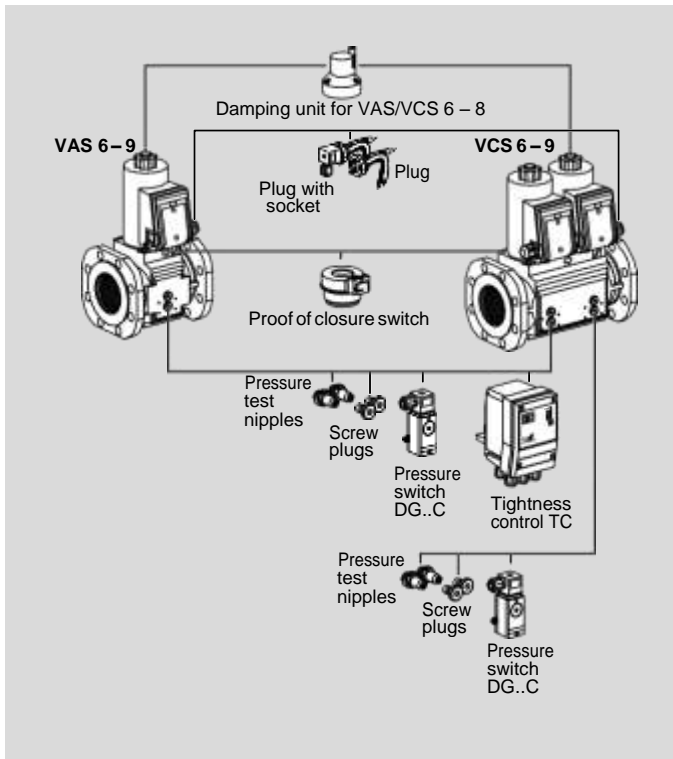

Modularly configurable with:

- Damping unit for VAS/VCS 6–8
- Proof of closure switch
- Plug
- Plug with socket

VCS 6–9 with threaded connections for:

- Screw plugs
- Pressure test nipples
- Tightness control TC
- Pressure switch DG..C for inlet/interspace pressure

1.4 Configuring solenoid valves for gas VAS 6–9 or double solenoid valves VCS 6–9 with adapter plate connection (Extended)

Gas solenoid valve and double solenoid valve with flanged connection (ISO or ANSI) for pipe connections from DN 65 to 125.

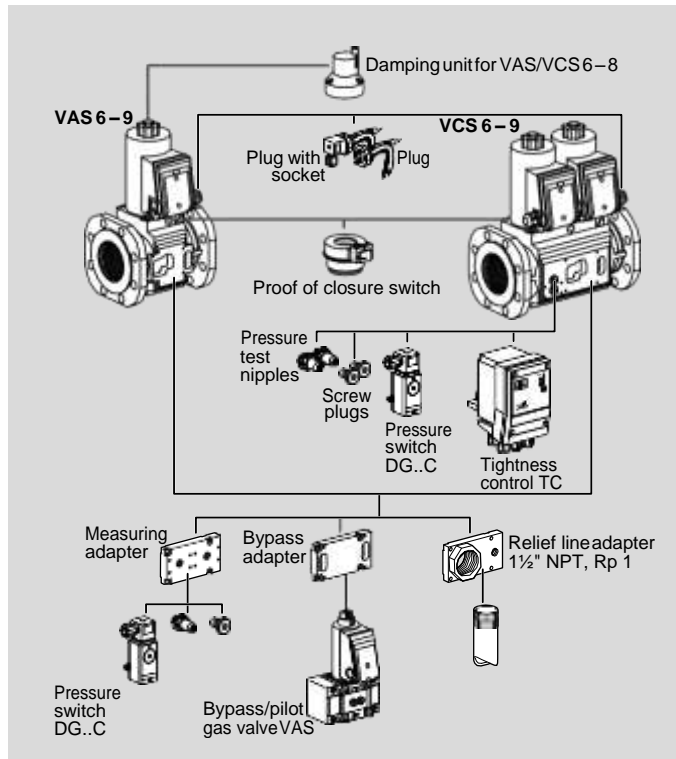

Modularly configurable with:

- Damping unit for VAS/VCS 6–8
- Proof of closure switch
- Plug
- Plug with socket

With adapter plates, expandable with:

- Pressure switch DG..C (VAS 6–9: for inlet/outlet pressure, VCS 6–9: for interspace/outlet pressure)
- Pressure test nipple
- Screw plug
- Bypass or pilot gas valve VAS

VCS 6–9

With two threaded connections for:

- Screw plugs
- Pressure test nipples
- Pressure switch DG..C for inlet/interspace pressure
- Tightness control TC

Expandable with relief line adapter (1½ NPT, Rp 1) for relief line.

1.5 Application examples for VAS 6–9, VCS 6–9

Gas solenoid valve with pilot gas valve and pressure switch

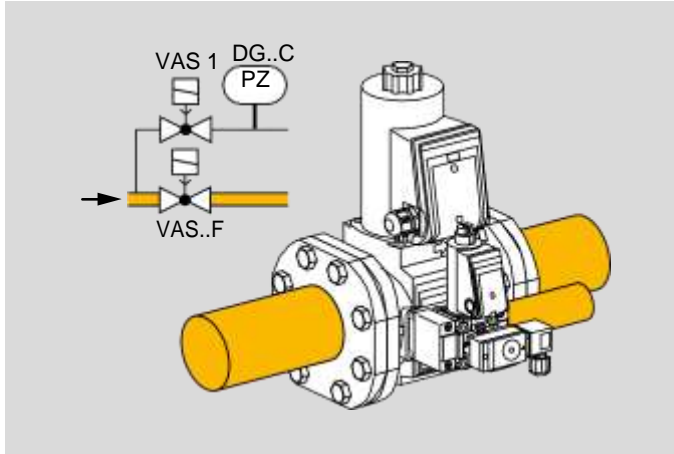

VAS..F..N: quick opening, quick closing, VAS 1 as pilot gas valve with pressure switch DG..C

Double solenoid valve with tightness control

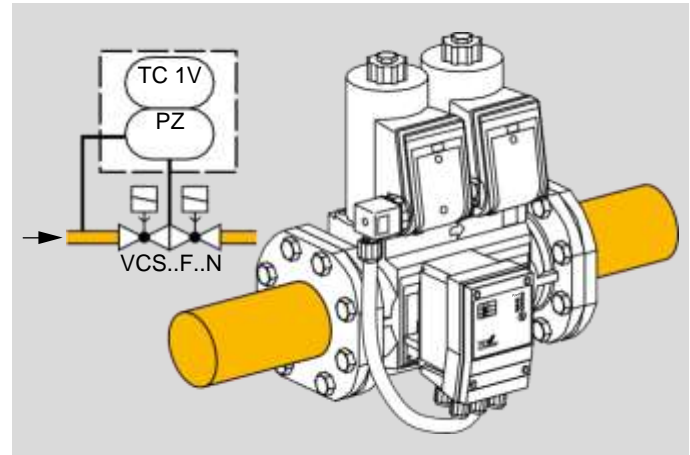

VCS..F..N: quick opening, quick closing valves, tightness control TC 1V

2 Certification

Certificates – see www.docuthek.com

Certified to SIL and PL



For systems up to SIL 3 pursuant to EN 61508 and PL e pursuant to ISO 13849. See page 62 (Safety-specific characteristic values for SIL and PL).

EU certified



- 2014/30/EU (EMC), Electromagnetic Compatibility Directive
- 2011/65/EU, RoHSII
- 2015/863/EU, RoHSIII
- (EU) 2016/426 (GAR), Gas Appliances Regulation
- EN 161:2011+A3:2013
- EN 126:2012
- EN 1854:2010

FM approved*



Factory Mutual Research Class: 7400 and 7411 Safety over-pressure slam shut valves. Designed for applications pursuant to NFPA 85 and NFPA 86. www.approvalguide.com

ANSI/CSA approved*



American National Standards Institute/Canadian Standards Association – ANSI Z21.21/CSA 6.5. www.csagroup.org – Class number: 3371-83 (natural gas, LPG), 3371-03 (natural gas, propane).

VAS 1–3 (120 V AC), VAS 6–8: UL listed*



Underwriters Laboratories – UL429 “Electrically operated valves”. www.ul.com

AGA approved*



Australian Gas Association, Approval No.: 3968. www.aga.asn.au

Eurasian Customs Union



The product VAS, VCS meets the technical specifications of the Eurasian Customs Union.

* Approval does not apply for 100 V AC or 200 V AC.

3 Function

The gas solenoid valve VAS is closed when it is disconnected from the power supply.

Opening: connect the system to the electrical power supply (alternating voltage will be rectified). The blue LED lights up. The coil's magnetic field pulls the armature with the attached valve discs upwards. The gas solenoid valve VAS opens. The double valve seat means that the forces from the inlet pressure are divided almost equally between the two valve seats.

Closing: disconnect the VAS from the electrical power supply. The blue LED goes out. The armature is pressed into its initial position by the closing spring. The gas solenoid valve closes within 1 s.

The strainer in the inlet of the gas solenoid valve prevents deposits of dirt particles on the valve seats. The pressure loss through the strainer is very low.

VAS 1-8..N, VAS 1-3..L

The flow rate can be varied by a flow adjusting screw on the actuator within a range from 20 to 100%. On VAS 1-3, the setting can be monitored on an indicator.

3.1 Solenoid valve for gas VAS..N, quick opening

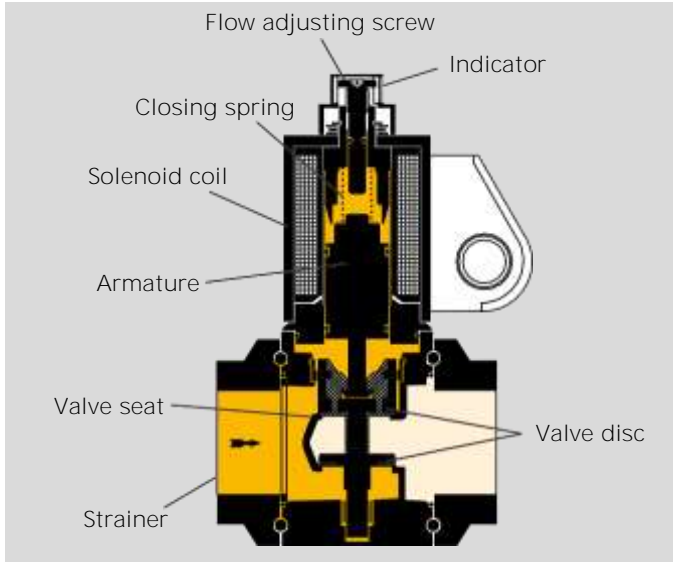

VAS 1-3..N

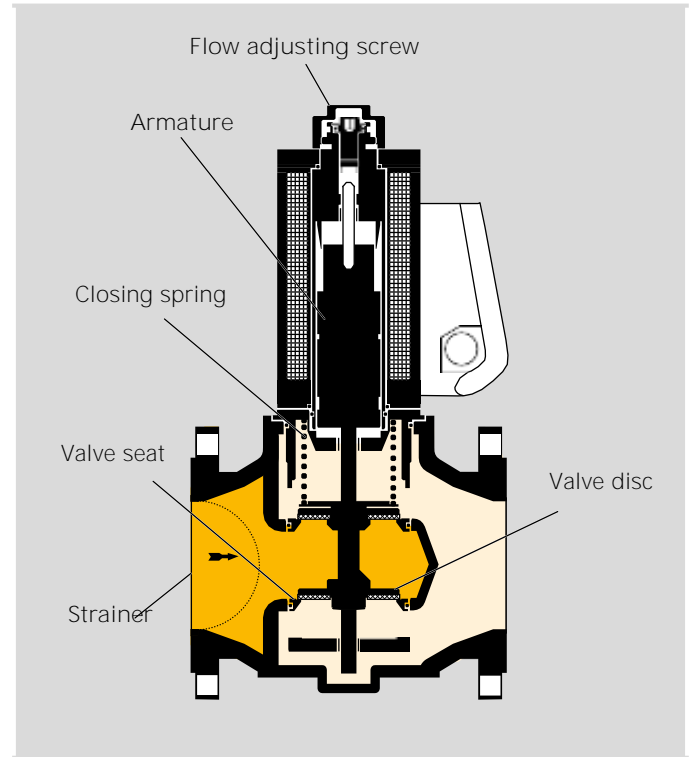

VAS 6-9..N

The solenoid valve for gas VAS..N opens within 0.5 s.

3.2 Solenoid valve for gas VAS..L, slow-opening

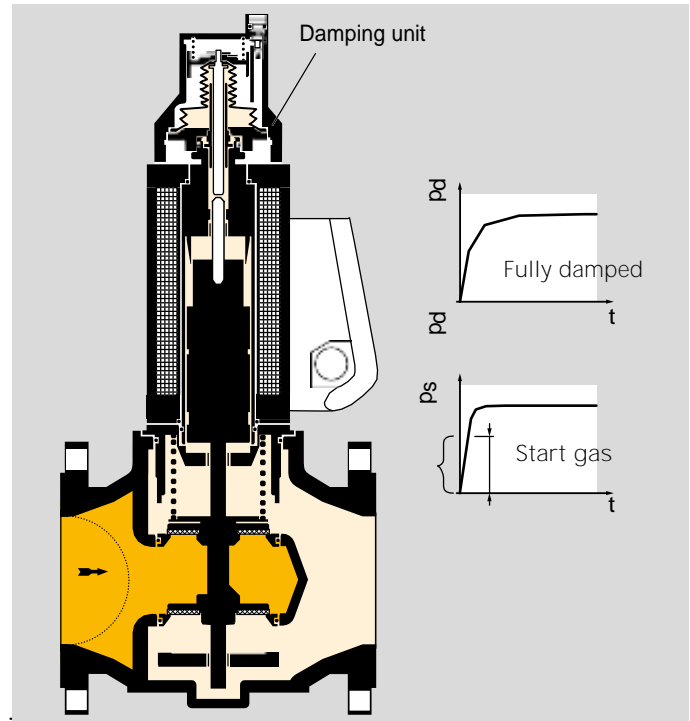
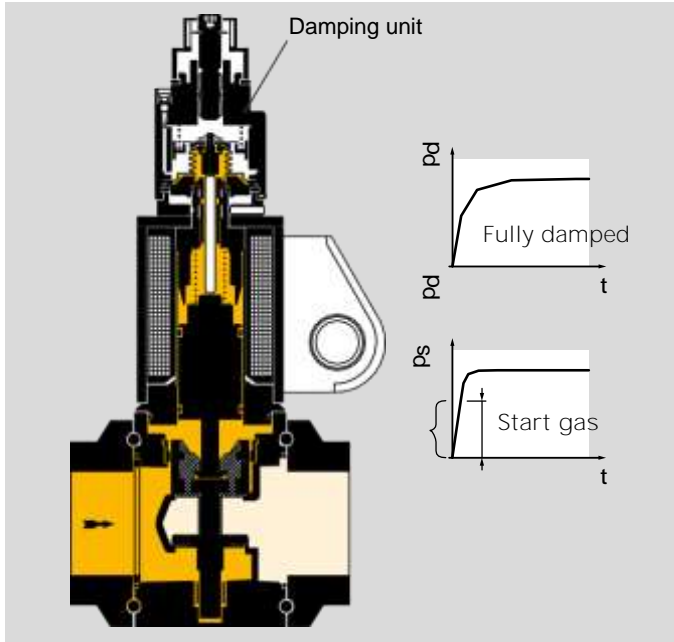

The solenoid valve for gas VAS..L opens within 10 s.

Start gas rate adjustment: the gas solenoid valve opens with a quick initial lift and then continues slowly until it is fully open. The start gas rate can be set. This setting is required, for example if a tightness control TC is to be used.

By turning the damping unit, the start gas rate can be set between 0 and 70%:

Turning it clockwise will decrease the start gas rate and turning it anti-clockwise will increase the start gas rate.

3.3 Solenoid valve for gas VAS..S/VAS..G, proof of closure switch with visual position indicator

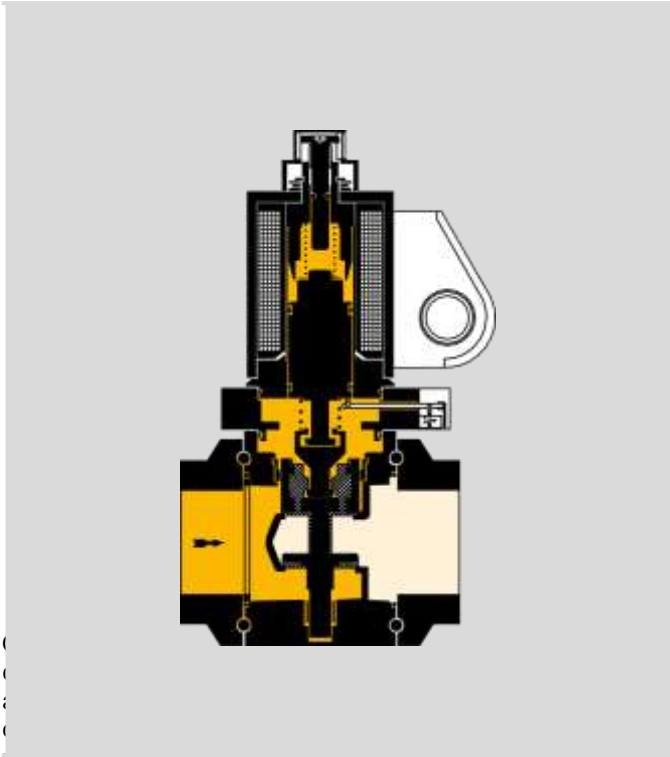

principle).

Closing: the gas solenoid valve VAS is disconnected from the electrical power supply and the closing spring presses the double valve disc on to the valve seat. Then the proof of closure switch is actuated. The visual position indicator is white for "closed".

The actuator cannot be rotated on a gas solenoid valve with a proof of closure switch and a visual position indicator.

NOTE: NFPA 86 – safety shut-off valve VAS..S must be fitted with an overtravel switch with a visual position indicator, and the burner-side pressure regulator with gas solenoid valve VAx..S must be fitted with a proof of closure switch with a visual position indicator. One gas solenoid valve must be verifiably closed. The closed position can be verified using the proof of closure switch of the gas solenoid valve VAS..S/VAS..G.

3.4 Connection diagram

Wiring to EN 60204-1.

Further connection options, see Operating instructions VAS 1–3, VCS 1–3 or Operating instructions VAS 6–9, VCS 6–9 at www.docuthek.com.

3.4.1 VAS with M20 cable gland

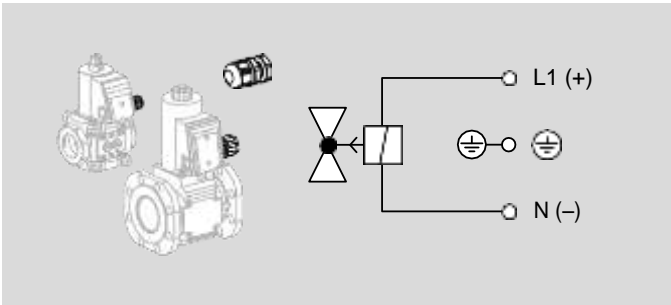

3.4.2 VAS with plug

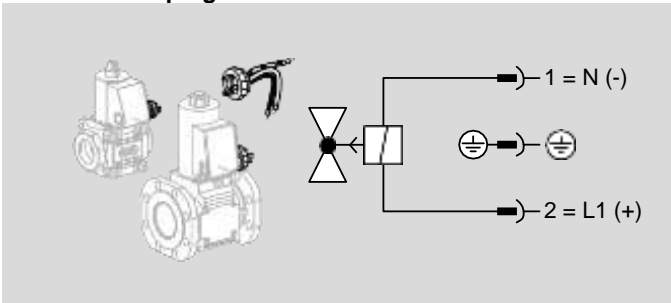

3.4.3 VAS..S/VAS..G. proof of closure switch with visual

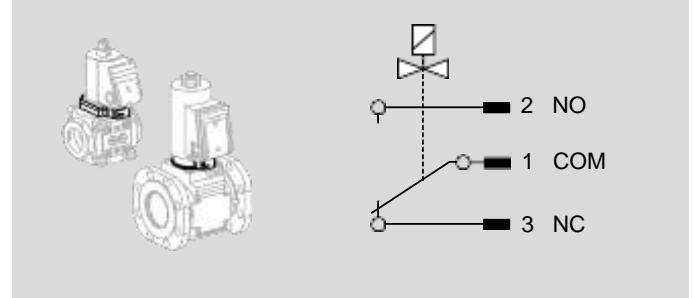

The designed lifetime of the proof of closure switch cannot be reached with frequent cycling operation, see page 50 (Technical data).

3.4.4 VCS with M20 cable gland

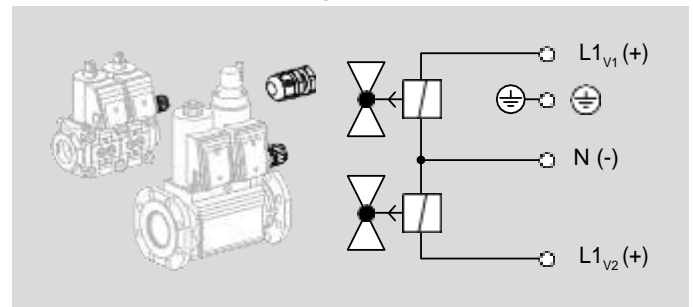

3.4.5 VCS with plug

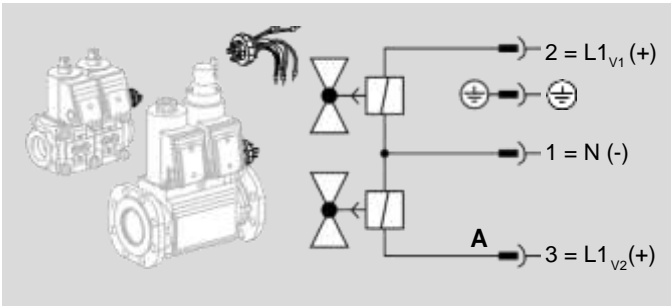

4 Flow rate

4.1 Calculating the nominal size

A web app selecting the correct product is available at www.adlatus.org.

4.2 VAS

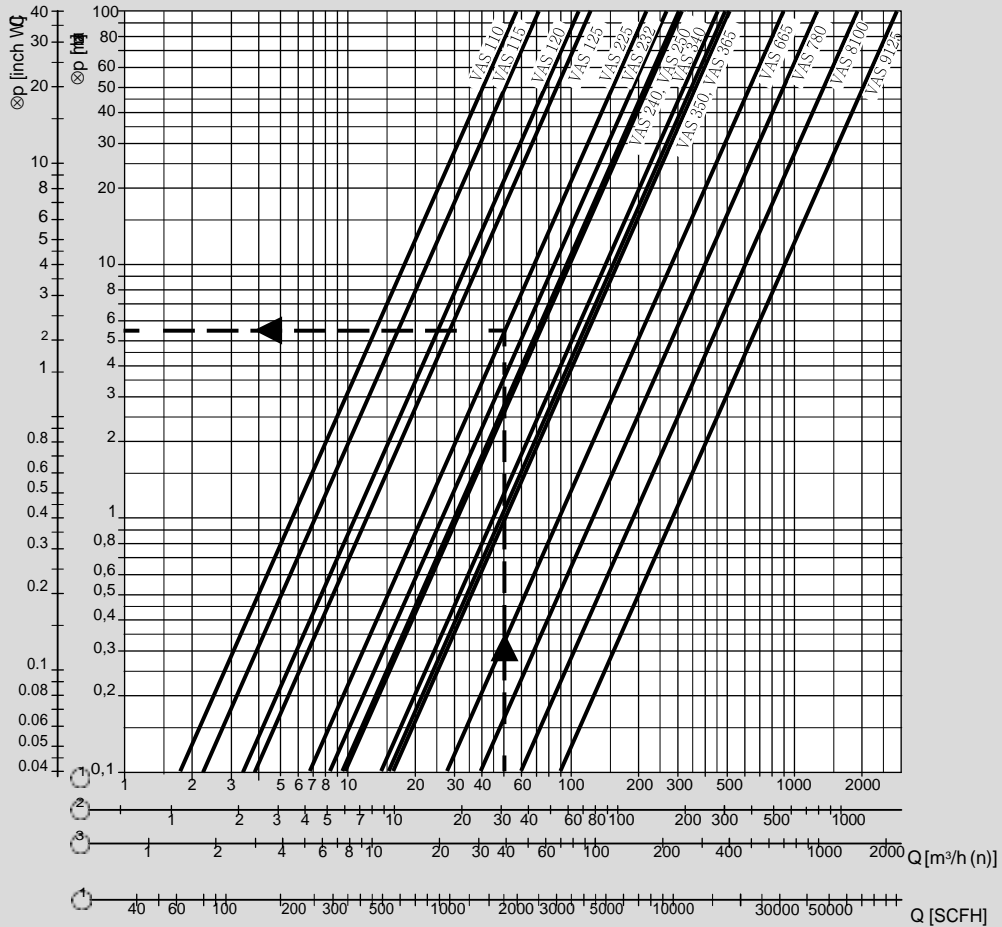

- 1 = natural gas ($\rho = 0.80 \text{ kg/m}^3$)
- 2 = propane ($\rho = 2.01 \text{ kg/m}^3$)
- 3 = air ($\rho = 1.29 \text{ kg/m}^3$)

The characteristic flow rate curves have been measured with the specified flanges and a fitted strainer.

* $Q_{min.}$ = rough specification for fully restricted flow adjustment and $\Delta p_{max.}$

When determining the pressure loss, operating cubic metres must be entered. Then the pressure loss Δp read must be multiplied by the absolute pressure in bar (positive pressure + 1) to account for the change in the medium's density.

Example

inlet pressure p_u (positive pressure) = 0.3 bar,

gas type: natural gas,

operating flow rate $Q = 50 \text{ m}^3/\text{h}$ (b),

Δp from diagram = 5.5 mbar,

$\Delta p = 5.5 \text{ mbar} \times (1 + 0.3) = 7.2 \text{ mbar}$ on the

solenoid valve VAS 225

4.3 VCS

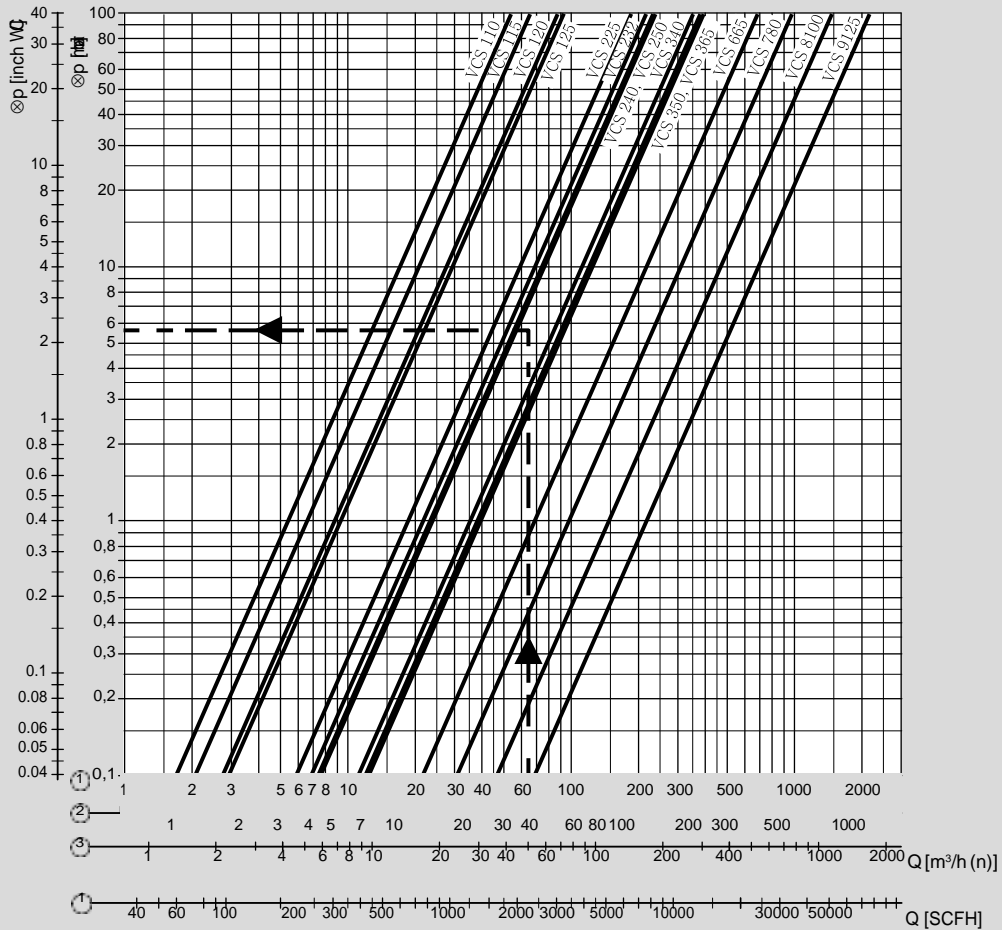

1 = natural gas ($\rho = 0.80 \text{ kg/m}^3$)

2 = propane ($\rho = 2.01 \text{ kg/m}^3$)

3 = air ($\rho = 1.29 \text{ kg/m}^3$)

The characteristic flow rate curves have been measured with the specified flanges and a fitted strainer.

* $Q_{min.}$ = rough specification for fully restricted flow adjustment and $\Delta p_{max.}$

When determining the pressure loss, operating cubic metres must be entered. Then the pressure loss Δp read must be multiplied by the absolute pressure in bar (positive pressure + 1) to account for the change in the medium's density.

Example

inlet pressure p_u (positive pressure) = 0.3 bar,

gas type: natural gas,

operating flow rate $Q = 64.8 \text{ m}^3/\text{h}$ (b),

Δp from diagram = 5.7 mbar,

$\Delta p = 5.7 \text{ mbar} \times (1 + 0.3) = 7.4 \text{ mbar}$ on the

solenoid valve VCS 232

5 Selection

5.1 ProFi

A web app selecting the correct product is available at www.adlatus.org.

5.2 Selection table for VAS 1–3

Option	VAS 1	VAS 2 25 – 32	VAS 2 40 – 50	VAS 3 40	VAS 3 50 – 65
DN	–, 10, 15, 25	–, 25, 32	40, 50	40	50, 65
Pipe connection	–, R, N	–, R, N	–, R, N, F	–, R, N, F	–, R, N, F
Opening properties	/N, /L	/N, /L	/N, /L	/N, /L	/N, /L
Mains voltage	W, Y, Q, P, K	W, Y, Q, P, K	W, Y, Q, P, K	W, Y, Q, P, K	W, Y, Q, P, K
Feedback ^{1) 3)}	S, G	S, G	S, G	S, G	S, G
Viewing side ³⁾	R, L	R, L	R, L	R, L	R, L
Electrical connection ⁴⁾	M20, plug, plug with socket	M20, plug, plug with socket	M20, plug, plug with socket	M20, plug, plug with socket	M20, plug, plug with socket
Accessories, right ³⁾	Screw plug, test nipple, DG 17–300 ²⁾ , VBY ¹⁾ , VAS 1	Screw plug, test nipple, DG 17–300 ²⁾ , VBY ¹⁾ , VAS 1	Screw plug, test nipple, DG 17–300 ²⁾ , VAS 1 ¹⁾	Screw plug, test nipple, DG 17–300 ²⁾ , VAS 1 ¹⁾	Screw plug, test nipple, DG 17–300 ²⁾ , VAS 1 ¹⁾
Accessories, left ³⁾	Screw plug, test nipple, DG 17–300 ²⁾ , VBY ¹⁾ , VAS 1	Screw plug, test nipple, DG 17–300 ²⁾ , VAS 1	Screw plug, test nipple, DG 17–300 ²⁾ , VAS 1 ¹⁾	Screw plug, test nipple, DG 17–300 ²⁾ , VAS 1 ¹⁾	Screw plug, test nipple, DG 17–300 ²⁾ , VAS 1 ¹⁾

¹⁾ Proof of closure switch and bypass/pilot gas valve cannot be fitted together on the same side.

²⁾ Specify the test point for inlet pressure p_u or outlet pressure p_d .

Order example

VAS 225R/NW

Fitted pressure switch for test point p_u

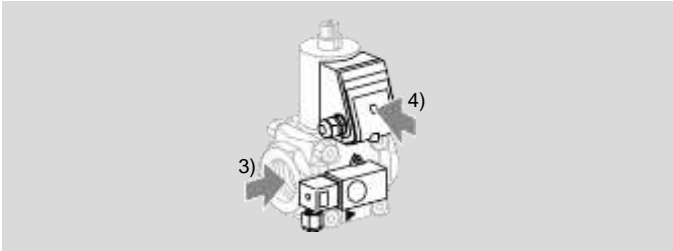

3) Viewed from the right/left: looking into the valve body in the direction of flow, see order example.

4) Viewing side for the electr. connection: looking at the connection box, see order example.

5.3 Selection table for VAS 6–9

Option	VAS 6	VAS 7	VAS 8	VAS 9
DN	65	80	100	125
Pipe connection	F, A	F, A	F, A	F, A
Inlet pressure	05	05	05	05
Opening properties	N, L	N, L	N, L	N, L
Mains voltage	W, Y, Q, P, K	W, Y, Q, P, K	W, Y, Q, P, K	W, Y, Q, P, K
Feedback ¹⁾	S, G	S, G	S, G	S, G
Viewing side ^{1) 3)}	R, L	R, L	R, L	R, L
Electrical connection ⁴⁾	M20, plug, plug with socket	M20, plug, plug with socket	M20, plug, plug with socket	M20, plug, plug with socket
Basic, prepared for adapter plates	B, E	B, E	B, E	B, E
Accessories, right, inlet ^{3) 5)}	/P, /M, /1, /2, /3, /4, /B ¹⁾ , /Z ¹⁾ , /V, /E	/P, /M, /1, /2, /3, /4, /B ¹⁾ , /Z ¹⁾ , /V, /E	/P, /M, /1, /2, /3, /4, /B ¹⁾ , /Z ¹⁾ , /V, /E	/P, /M, /1, /2, /3, /4, /B ¹⁾ , /Z ¹⁾ , /V, /E
Accessories, right, putlet ^{3) 5)}	P, M, 1, 2, 3, 4	P, M, 1, 2, 3, 4	P, M, 1, 2, 3, 4	P, M, 1, 2, 3, 4

¹⁾ Proof of closure switch and bypass/pilot gas valve cannot be fitted together on the same side.

²⁾ Specify the test point for inlet pressure p_u or outlet pressure p_d .

Order example

VAS 665F05NW3E/P2/PP

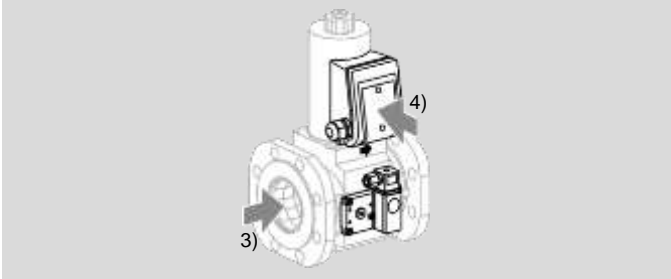

3) Viewed from the right/left: looking into the valve body in the direction of flow, see order example.

4) Viewing side for the elect. connection: looking at the connection box, see order example.

5) The same accessories can be selected for the other viewing side.

5.4 Typenschlüssel VAS 1–9

VAS	Solenoid valve for gas
1-9	Sizes
10–125	Inletandoutletflangenominalsize
R	Rp internal thread
F	Flange to ISO 7005
05	p_u max. 500 mbar
/N	Quick opening, quick closing
/L	Slow opening, quick closing
W	Mains voltage 230 V AC, 50/60 Hz
Q	Mains voltage 120 V AC, 50/60 Hz
K	Mains voltage 24 V DC
A	Mains voltage 120-230 V AC, 50/60 Hz
S	With POC/CPS and visual position indicator
G	With POC/CPS for 24 V and visual position indicator
R	Viewing side: right
L	Viewing side: left
3	Electrical connection via cable gland
B	Basic
E	Prepared for adapter plates
/P	Accessory, right, inlet: screw plug
/M	Accessory, right, inlet: pressure test point
/1	Accessory, right, inlet: pressure switch DG 17/VC
/2	Accessory, right, inlet: pressure switch DG 40/VC
/3	Accessory, right, inlet: pressure switch DG 110/VC
/4	Accessory, right, inlet: pressure switch DG 300/VC
P	Accessory, right, outlet: screw plug

M	Accessory, right, outlet: pressure test point
1	Accessory, right, outlet: pressure switch DG 17/VC
2	Accessory, right, outlet: pressure switch DG 40/VC
3	Accessory, right, outlet: pressure switch DG 110/VC
4	Accessory, right, outlet: pressure switch DG 300/VC
	The same accessories can be selected for the left- or right-hand side.

5 .5 Selection table for VCS 1–3

Option	VCS 1	VCS 2 25 – 32	VCS 2 40 – 50	VCS 3 40	VCS 3 50 – 65
DN	–, 10, 15, 25	–, 25, 32	40, 50	40	50, 65
Pipe connection	–, R, N	–, R, N	–, R, N, F	–, R, N, F	–, R, N, F
Inlet pressure	05	05	05	05	05
Filter module VMF	F	F	F	F	F
V1 opening properties	N, L	N, L	N, L	N, L	N, L
V2 opening properties	N, L	N, L	N, L	N, L	N, L
Fine-adjusting valve VMV, measuring orifice VMO	V, O	V, O	V, O	V, O	V, O
Mains voltage	W, Y, Q, P, K	W, Y, Q, P, K	W, Y, Q, P, K	W, Y, Q, P, K	W, Y, Q, P, K
Feedback ¹⁾	S, G	S, G	S, G	S, G	S, G
Viewing side ³⁾	R, L	R, L	R, L	R, L	R, L
Electrical connection ⁴⁾	M20, plug, plug with socket	M20, plug, plug with socket	M20, plug, plug with socket	M20, plug, plug with socket	M20, plug, plug with socket
Accessories, right, inlet ³⁾	/P, /M, 12), 22), 32), 42)	/P, /M, 12), 22), 32), 42)	/P, /M, 12), 22), 32), 42)	/P, /M, 12), 22), 32), 42)	/P, /M, 12), 22), 32), 42)
Accessories, left, inlet ³⁾	P, M, 12), 22), 32), 42), BY ¹⁾ , BS ¹⁾ , BY ¹⁾ , ZY ¹⁾ , ZS ¹⁾ ,	P, M, 12), 22), 32), 42), BY ¹⁾ , BS ¹⁾ , BY ¹⁾ , ZY ¹⁾ , ZS ¹⁾ ,	P, M, 12), 22), 32), 42), BY ¹⁾ , BS ¹⁾ , BY ¹⁾ , ZY ¹⁾ , ZS ¹⁾ ,	P, M, 12), 22), 32), 42), BY ¹⁾ , BS ¹⁾ , BY ¹⁾ , ZY ¹⁾ , ZS ¹⁾ ,	P, M, 12), 22), 32), 42), BY ¹⁾ , BS ¹⁾ , BY ¹⁾ , ZY ¹⁾ , ZS ¹⁾ ,

¹⁾ Proof of closure switch and bypass/pilot gas valve cannot be fitted together on the same side.

²⁾ Specify the test point for inlet pressure p_u or outlet pressure p_d . When attaching DG..VC for p_z , the installation space left at the other valve is only sufficient for screw plugs.

Order example

VCS 240R/40R05NNWR3/2-PP/PPPP

Fitted pressure switch for test point p_u

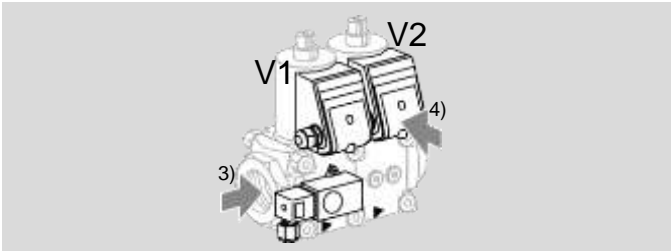

3) Viewed from the right/left: looking into the valve body in the direction of flow, see order example.

4) Viewing side for the electr. connection: looking at the connection box, see order example.

5.6 Selection table for VCS 6–9

Option	VCS 6	VCS 7	VCS 8	VCS 9
DN	65	80	100	125
Pipe connection	F, A	F, A	F, A	F, A
Inlet pressure	05	05	05	05
V1 opening properties	N, L	N, L	N, L	N, L
V2 opening properties	N, L	N, L	N, L	N, L
Mains voltage	W, A, Q, K	W, A, Q, K	W, A, Q, K	W, A, Q, K
Feedback ¹⁾	S, G	S, G	S, G	S, G
Viewing side ³⁾	R, L	R, L	R, L	R, L
Electrical connection ⁴⁾	M20, plug, plug with socket	M20, plug, plug with socket	M20, plug, plug with socket	M20, plug, plug with socket
Basic, prepared for adapter plates	B, E	B, E	B, E	B, E
Accessories, right, inlet ^{3) 5)}	/P, /M, /12), /2 ²⁾ , /3 ²⁾ , /4 ²⁾	/P, /M, /12), /2 ²⁾ , /3 ²⁾ , /4 ²⁾	/P, /M, /12), /2 ²⁾ , /3 ²⁾ , /4 ²⁾	/P, /M, /12), /2 ²⁾ , /3 ²⁾ , /4 ²⁾
Accessories, right, interspace 1 ^{3) 5)}	P, M, 12), 22), 32), 42)	P, M, 12), 22), 32), 42)	P, M, 12), 22), 32), 42)	P, M, 12), 22), 32), 42)
Accessories, right, interspace 2 ^{3) 5)}	P, M, 12), 22), 32), 42), B, Z, V, E	P, M, 12), 22), 32), 42), B, Z, V, E	P, M, 12), 22), 32), 42), B, Z, V, E	P, M, 12), 22), 32), 42), B, Z, V, E
Accessories, right, outlet ^{3) 5)}	P, M, 12), 22), 32), 42)	P, M, 12), 22), 32), 42)	P, M, 12), 22), 32), 42)	P, M, 12), 22), 32), 42)

¹⁾ Specify wiring of 1st or 2nd proof of closure switch (or “none”).

²⁾ Specify the test point for inlet pressure p_u , interspace pressure p_z or outlet pressure p_d .

Order example

VCS 665F05NLW3E/2B-/PPPP

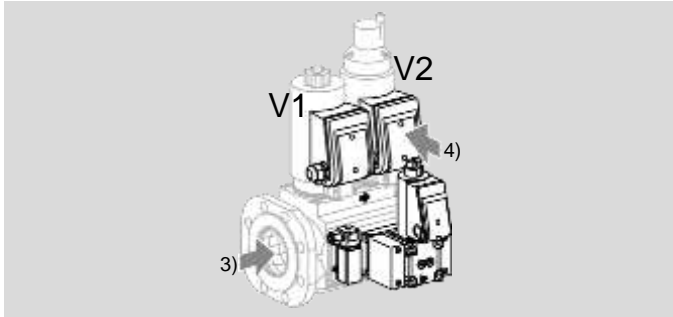

- 3) Viewed from the right/left: looking into the valve body in the direction of flow, see order example.
- 4) Viewing side for the electr. connection: looking at the connection box, see order example.
- 5) The same accessories can be selected for the other viewing side.

5.7 Typenschlüssel VCS 1–9

VCS	Double solenoid valve
1–3, 6–9	Sizes
E	EU certified
10–125	Inletandoutletflangenominalsize
R	Rp internal thread
F	Flange to ISO 7005
05	p_u max. 500 mbar
L	Valve 1 slow opening, quick closing
N	Valve 1 quick opening, quick closing, with flow adjustment
L	Valve 2 slow opening, quick closing
N	Valve 2 quick opening, quick closing, with flow adjustment
W	Mains voltage 230 V AC, 50/60 Hz
Q	Mains voltage 120 V AC, 50/60 Hz
K	Mains voltage 24 V DC
A	Mains voltage 120-230 V AC, 50/60 Hz
S	With POC/CPS and visual position indicator G
	With POC/CPS for 24 V and visual position indicator R
	Viewing side: right
L	Viewing side: left
3	Electrical connection via cable gland
B	Basic
E	Prepared for adapter plates
/P	Accessory, right, inlet: screw plug
/M	Accessory, right, inlet: pressure test point
P	Accessory, right, interspace 1: screw plug

M	Accessory, right, interspace 1: pressure test point P
	Accessory, right, interspace 2: screw plug M
	Accessory, right, interspace 2: pressure test point P
	Accessory, right, outlet: screw plug
M	Accessory, right, outlet: pressure test point
	The same accessories can be selected for the left- or right-hand side.

6 Project planning information

6.1 Connections p_u , p_d , p_z

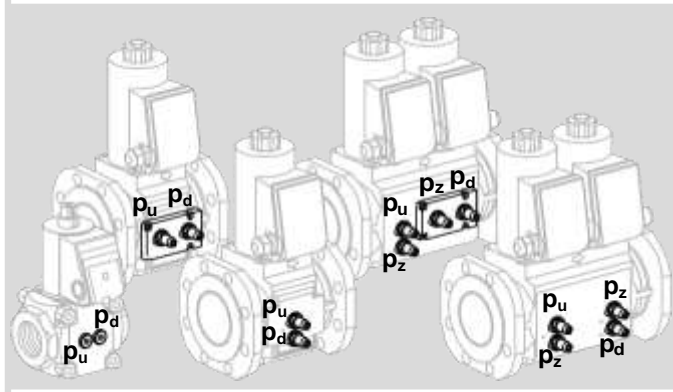

The inlet pressure p_u , the interspace pressure p_z and the outlet pressure p_d can be measured at the pressure test points on both sides.

6.2 Installation

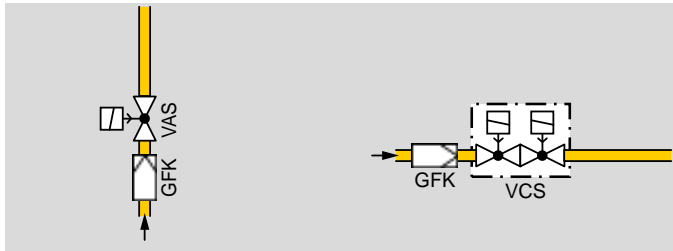

Installation position: black solenoid actuator in the vertical upright position or tilted up to the horizontal, not upside down.

Sealing material and thread cuttings must not be allowed to get into the valve housing. Install a filter upstream of every system.

The pipe system must be designed in such a way so as to avoid strain at the connections.

Do not store or install the unit in the open air.

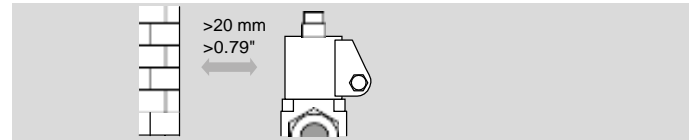

The device must not be in contact with masonry. Minimum clearance 20 mm (0.79 inch).



Ensure that there is sufficient space for installation, adjustment and maintenance work. Minimum clearance of 25 cm (9.8 inch) above the black solenoid actuator.

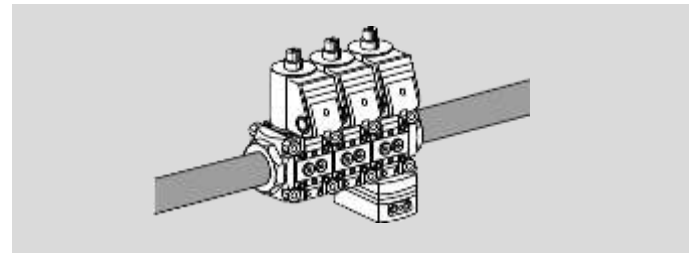

If more than three valVario controls are installed in line, the controls must be supported.

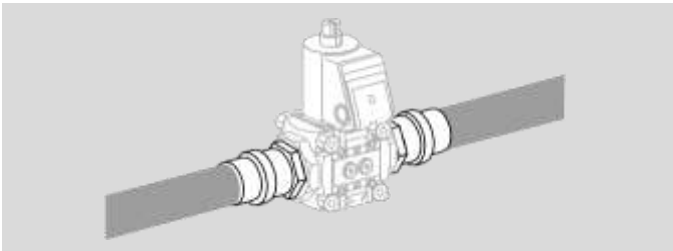

The seals in some gas compression fittings are approved for temperatures of up to 70°C (158°F). This temperature limit will not be exceeded if the flow through the pipe is at least 1 m³/h (35.31 SCFH) of gas and the maximum ambient temperature is 50°C (122°F).

In the case of a VCx combination, it is recommended to always install the bypass/pilot gas valve on the rear of the second valve and the tightness control on the viewing side of the first valve, together with the connection box.

6 .3 Design specifications

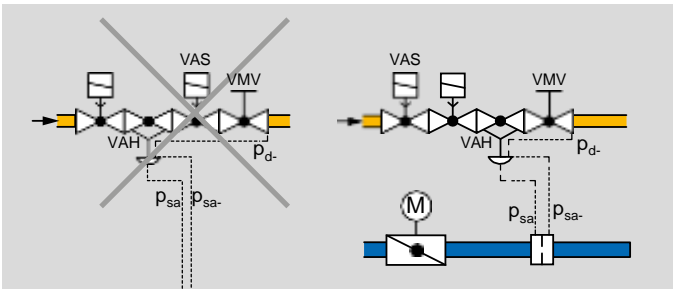

It is not permitted to install a gas solenoid valve VAS downstream of flow rate regulator VAH and upstream of fine-adjusting valve VMV. The VAS would no longer be able to

perform its function as a second safety valve if installed in the above-mentioned position.

The measuring orifice in the air line for impulse lines p_{sa} and p_{sa-} must always be installed downstream of the air control valve.

6 .4 Note on settings

VAS 1–3..L, VCS 1–3..L: damping speed

The opening speed can be influenced by turning the nozzle screw on the damping unit, see Operating instructions VAS 1–3, VCS 1–3 at www.docuthek.com.

6 .5 Opening times

VAS../N quick opening: ≤ 1 s;

VAS../L slow opening: up to 10 s.

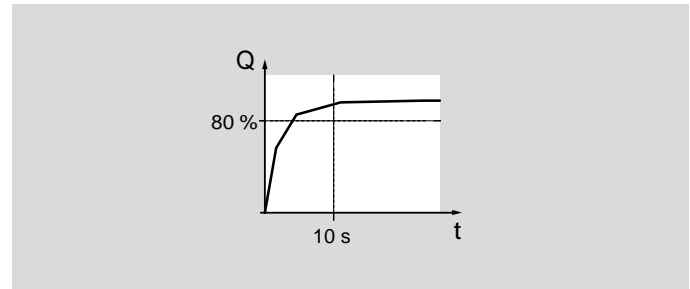

6 .6 Flow rate for bypass or pilot gas valve

Characteristic flow rates, see accessories, page 38 (Bypass/pilot gas valve VAS 1) and page 42 (Bypass/pilot gas valve VBY8).

6.7 Tightness control TC 1V

Tightness control TC 1V can be mounted directly onto the valve, see accessories, page 48 (Tightness control TC 1V).

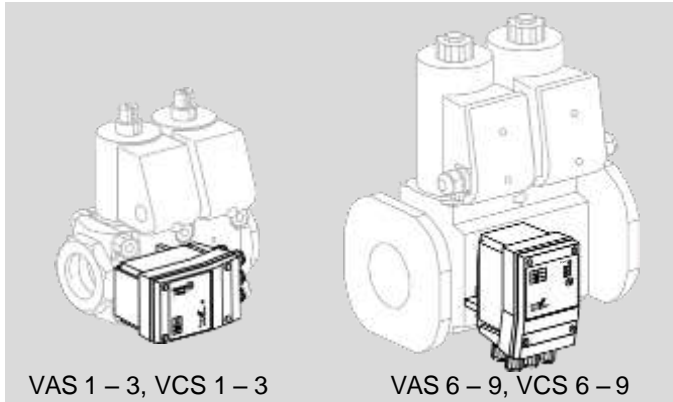

In the case of double solenoid valves, the position of the connection box can only be changed by removing the actuator and reinstalling it rotated by 90° or 180°. The solenoid actuator cannot be rotated on solenoid valves with proof of closure switch VCx..S or VCx..G.

Tightness control TC 1V and bypass/pilot gas valve cannot be fitted together on the same side of the double block valve.

6.8 Electrical connection

Use temperature-resistant cable (>90°C) for the electrical connection.



The solenoid actuator heats up during operation. Surface temperature approx. 85°C (185°F) pursuant to EN 60730-1.

7 Accessories

7.1 Pressure switch for gas DG..C

Monitoring the inlet pressure p_u : the electrical plug of the pressure switch for gas points towards the inlet flange.
Monitoring the outlet pressure p_d : the electrical plug of the pressure switch for gas points towards the outlet flange.

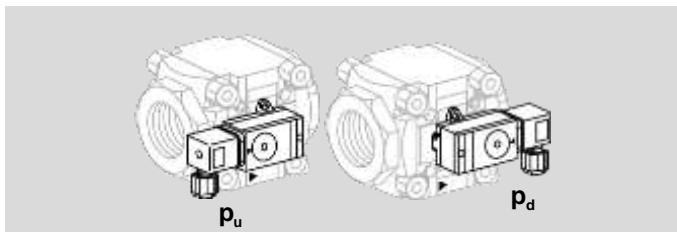

Scope of delivery:

- 1 x pressure switch for gas,
- 2 x retaining screws,
- 2 x sealing rings.

Also available with gold-plated contacts for voltages of 5 to 250 V.

DG..VC

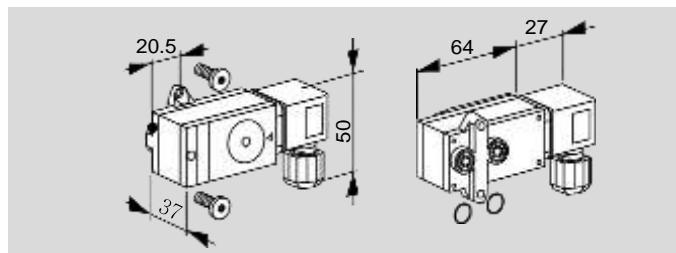

Type	Adjusting range [mbar]
DG 17VC	2 to 17
DG 40VC	5 to 40
DG 110VC	30 to 110
DG 300VC	100 to 300

DG..VCT

with AWG 18 connection conductors

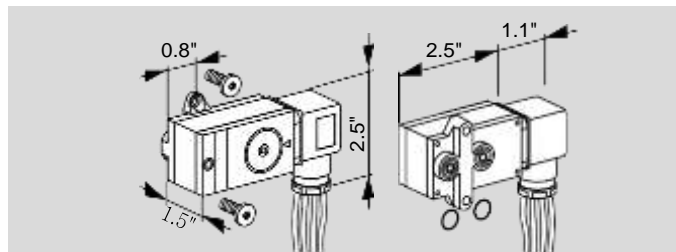

Type	Adjusting range [°WC]
DG 17VCT	0.8 to 6.8
DG 40VCT	2 to 16
DG 110VCT	12 to 44
DG 300VCT	40 to 120

7.1.1 Installation on VCS 1–3

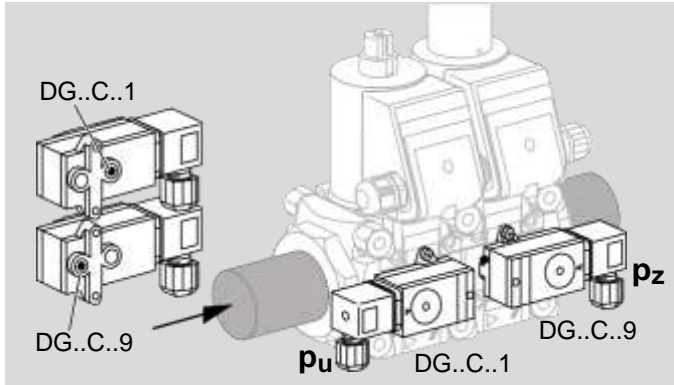

If, when monitoring the inlet or outlet pressure and the interspace pressure, both pressure switches should be fitted on the same side of the valve, only the combination DG..C..1 and DG..C..9 may be used for design reasons. The socket of the gas pressure switch DG..C..1 points towards the test point p_u (towards the inlet flange). The DG..C..9 is also optionally available for monitoring the interspace pressure p_z . The socket points towards the outlet flange.

7.1.2 DG..C fastening set for VAx 1–3

Order No.: 74921507, scope of delivery:

- 2 x retaining screws,
- 2 x sealing rings.

7.1.3 Installation on VAS 6–9

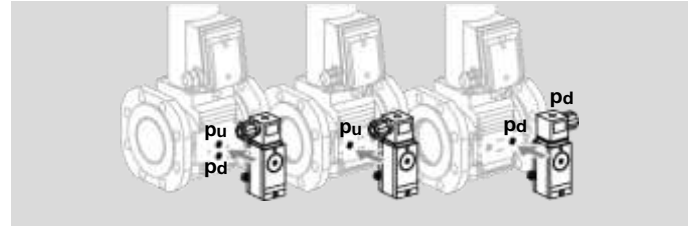

Monitoring the inlet pressure p_u : the pressure switch for gas is mounted on the inlet side.

Monitoring the outlet pressure p_d : the pressure switch for gas is mounted on the outlet side.

7.1.4 Installation on VCS 6–9

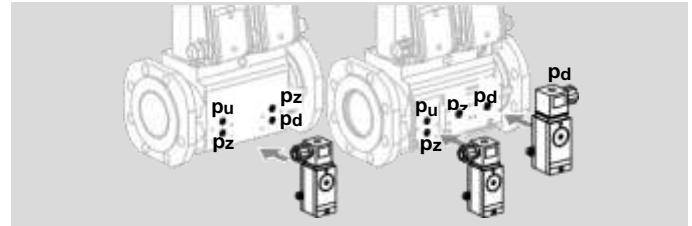

Monitoring the inlet pressure p_u , interspace pressure p_z , outlet pressure p_d : for this, attach the pressure switch for gas at the relevant position in each case.

7.2 Bypass/pilot gas valve VAS 1

7.2.1 Flow rate, VAS 1 attached to VAS 1, VAS 2, VAS 3

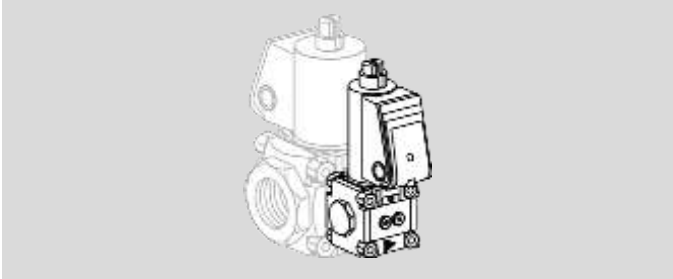

The characteristic flow rate curves have been measured for bypass valve VAS 1 with connection pipe diameter 1 to 10 mm (0.04–0.4") and for the pilot gas valve with 10 mm connection pipe.

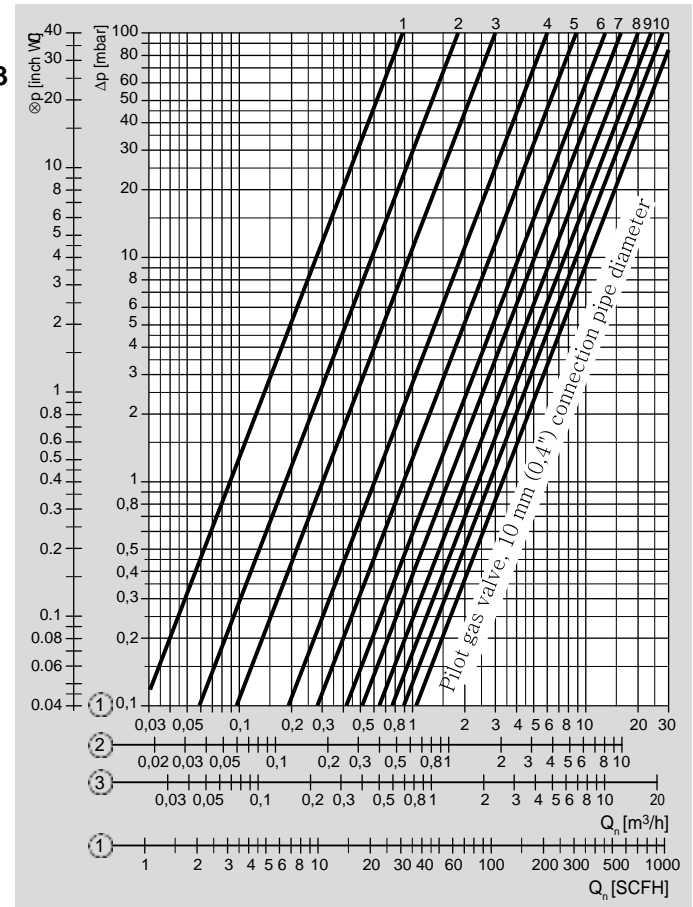

1 = natural gas ($\rho = 0.80 \text{ kg/m}^3$)

2 = propane ($\rho = 2.01 \text{ kg/m}^3$)

3 = air ($\rho = 1.29 \text{ kg/m}^3$)

7.2.2 Scope of delivery of VAS 1 for VAS 1, VAS 2, VAS 3

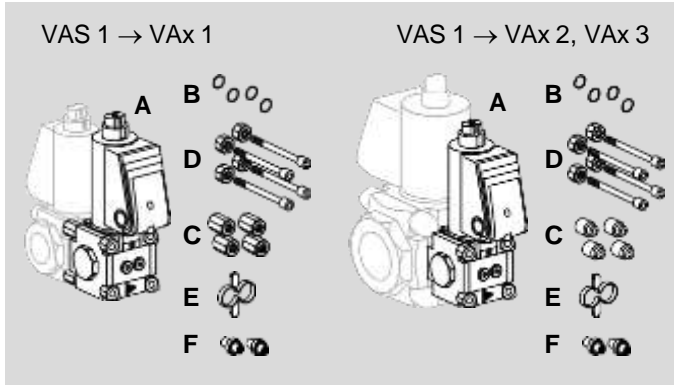

- A 1 x bypass/pilot gas valve VAS 1,
- B 4 x O-rings,
- C 4 x double nuts for VAS 1 → VAS 1,
- C 4 x spacer sleeves for VAS 1 → VAS 2/VAS 3,
- D 4 x connection parts,
- E 1 x mounting aid.

Pilot gas valve VAS 1:

F 1 x connection pipe, 1 x sealing plug, if the pilot gas valve has a threaded flange on the outlet side.

Bypass valve VAS 1:

F 2 x connection pipes, if the bypass valve has a blind flange on the outlet side.

Standard: Ø 10 mm.

Other connection pipes (F) with bypass diameter as of 1 mm are available.

Ø	Order No .
1 mm	74923877
2 mm	74923910
3 mm	74923911
4 mm	74923912
5 mm	74923913
6 mm	74923914
7 mm	74923915
8 mm	74923916
9 mm	74923917
10 mm	74923918

7.2.3 Flow rate, VAS 1 attached to VAS 6–9, VCS 6–9

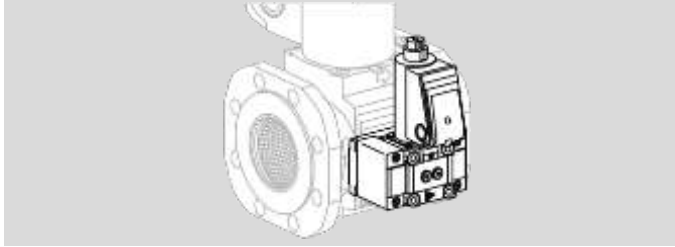

The adjusting range for the bypass valve, and pilot gas valve, VAS 1 was determined using the values measured for open flow adjustment ($Q_{max.}$) and fully reduced flow adjustment ($Q_{min.}$).

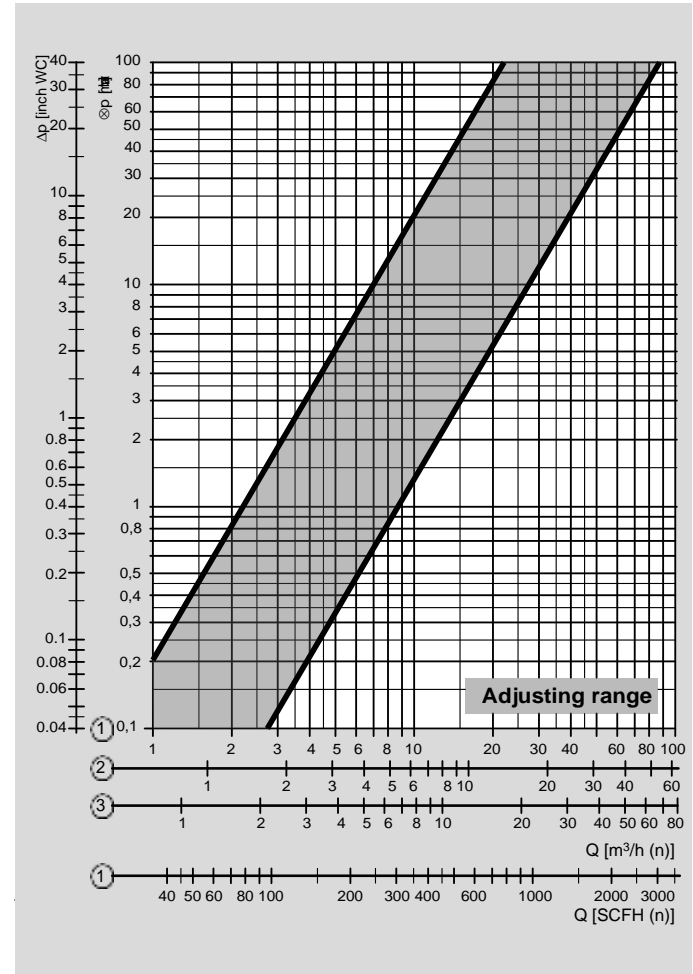

7.2.4 Scope of delivery of VAS 1 for VAS 6–9, VCS 6–9

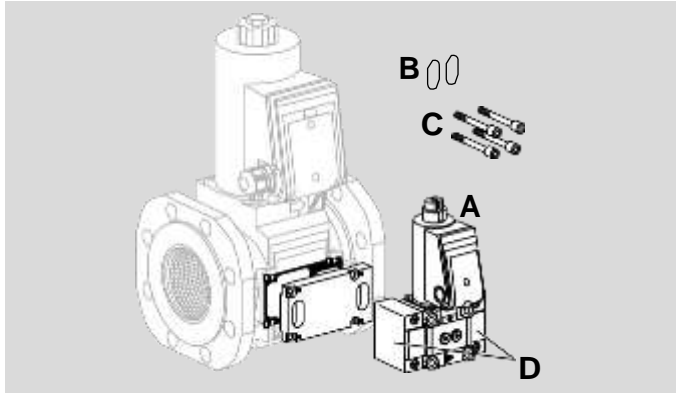

A 1 x bypass or pilot gas valve VAS 1,

B 2 x flange O-rings,

C 4 x connecting screws.

Bypass valve VAS 1:

D 2 x adapter flanges.

Pilot gas valve VAS 1:

D 1 x adapter flange,

1 x adapter flange with threaded hole.

For connection to VAS 6–9, VCS 6–9, the adapter plate must be ordered separately, see page 45 (Bypass adapter).

7.3 Bypass/pilot gas valve VBY 8

7.3.1 Flow rate, VBY

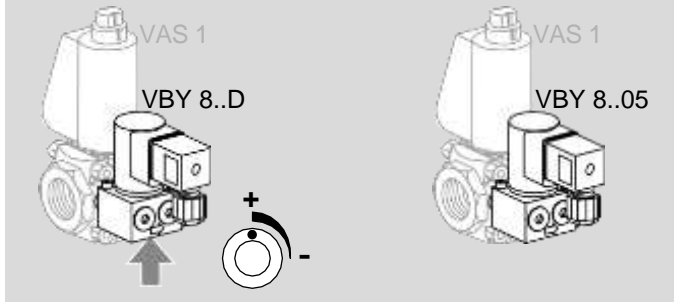

VBY 8..D

The flow rate can be set by turning the flow rate restrictor (4 mm/0.16" hexagon socket) ¼ of a turn. Flow rate: 10 to 100%.

VBY 8 . .05

The flow is routed through a 0.5 mm (0.02") nozzle and thus has a fixed characteristic flow rate curve. Adjustment is not possible.

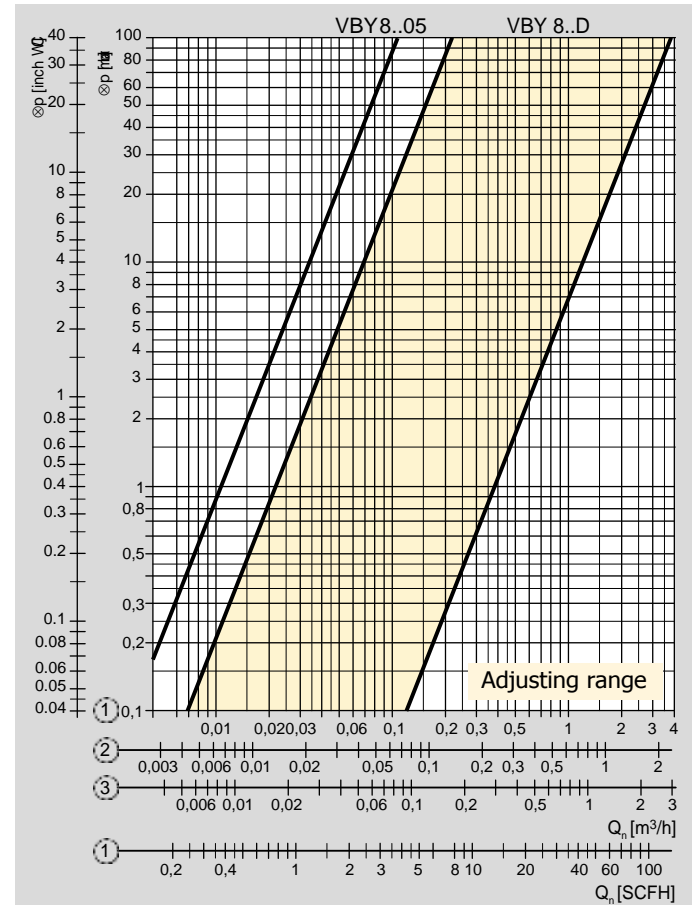

1 = natural gas ($\rho = 0.80 \text{ kg/m}^3$)

2 = propane ($\rho = 2.01 \text{ kg/m}^3$)

3 = air ($\rho = 1.29 \text{ kg/m}^3$)

7.3.2 Scope of delivery of VBY for VAS 1

For mounting on gas solenoid valve VAS 1 and double solenoid valve VCS1.

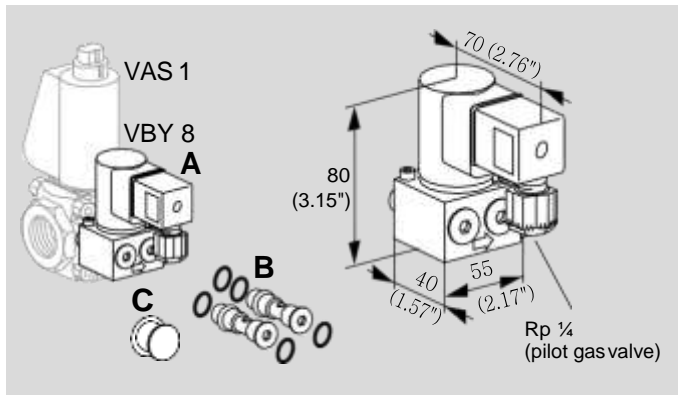

Scope of delivery of VBY6 8I as bypass valve

- A** 1 x bypass valve VBY 8I,
- B** 2 x retaining screws with 4 x O-rings: both retaining screws have a bypass orifice,
- C** grease for O-rings.

Scope of delivery of VBY6 8R as pilot gas valve

- A** 1 x pilot gas valve VBY 8R,
- B** 2 x retaining screws with 5 x O-rings: one retaining screw has a bypass orifice (2 x O-rings), the other does not (3 x O-rings),
- C** grease for O-rings.

7.3.3 Type code

VBY	Bypass valve
10	Nominal size
I	For internal pilot gas pick-up
R	For external pilot gas pick-up
01	p_u max. 100 mbar
N	Quick opening, quick closing
D	With flow adjustment
6	3-pin standard socket
W	Mains voltage 230 V AC, 50/60 Hz

7.4 Pressure test nipples

Test nipples to check the inlet pressure p_u , interspace pressure p_z and outlet pressure p_d .

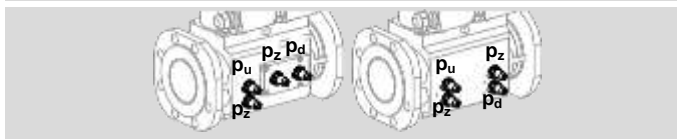
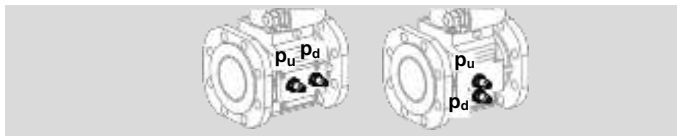

Scope of delivery

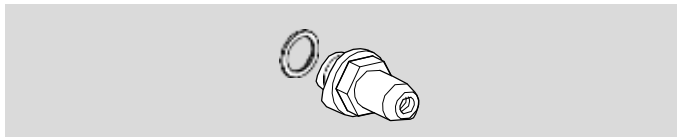

1 x test nipple with 1 x profiled sealing ring.

Rp ¼: Order No. 74923390,

¼ NPT: Order No. 75455894.

7.5 Cable gland set

When wiring double solenoid valve VCS 1–3, the connection boxes are to be connected using a cable gland set. The cable gland set can only be used if the connection boxes are at the same height and on the same side and if both valves are equipped either with or without a proof of closure switch.



VA 1, Order No. 74921985,

VA 2, Order No. 74921986,

VA 3, Order No. 74921987.

7.6 Attachment block VAS 1–3

For locked installation of pressure gauge or other accessories on the gas solenoid valve VAS 1–3.

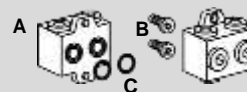

Attachment block Rp ¼, Order No. 74922228,

Attachment block NPT, Order No. 74926048.

Scope of delivery:

A 1 x attachment block,

B 2 x self-tapping screws for installation,

C 2 x O-rings.

7.7 Seal set for sizes 1–3

When retrofitting accessories or a second valVario control or when servicing, we recommend replacing the seals.

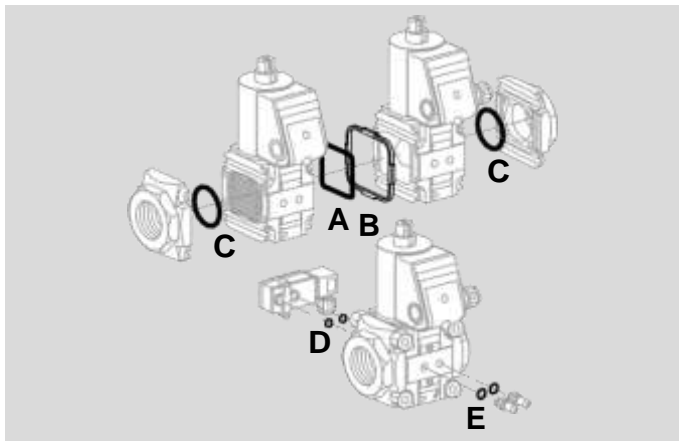

VAS 1–3

VA 1, Order No. 74921988,

VA 2, Order No. 74921989,

VA 3, Order No. 74921990.

Scope of delivery:

A 1 x double block seal,

B 1 x retaining frame,

C 2 x O-rings (flange),

D 2 x O-rings (pressure switch),

for test nipple/screw plug:

E 2 x sealing rings (flat sealing),

2 x profiled sealing rings.

VCS 1-3

VA 1, Order No. 74924978,

VA 2, Order No. 74924979,

VA 3, Order No. 74924980.

Scope of delivery:

A 1 x double block seal,

B 1 x retaining frame.

7.8 Adapter plates for VAS/VCS 6–9

7.8.1 Bypass adapter

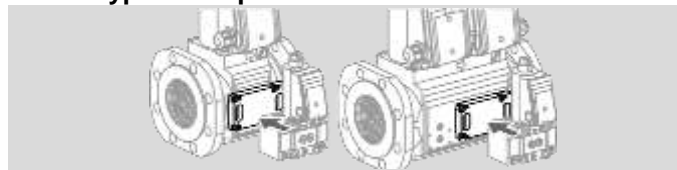

For connecting the bypass/pilot gas valve VAS 1.

Order No. 74923023

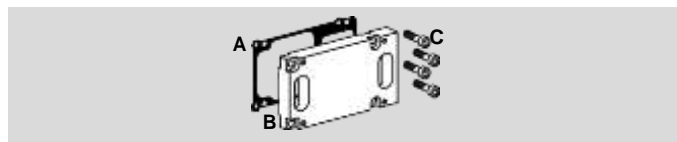

Scope of delivery:

A 1 x seal,

B 1 x bypass plate,

C 4 x M5 set screws.

7.8 .2 Measuring adapter

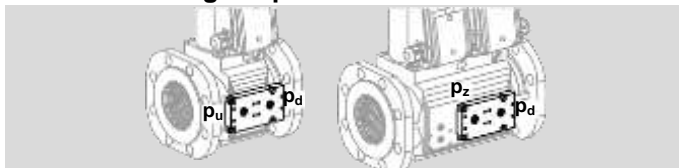

For the connection of the pressure switch DG..C, with a screw plug or pressure test nipple.

VAS/VCS 6–9, Order No. 74923021,
 VAS..T/VCS..T 6–9, Order No. 74923022.

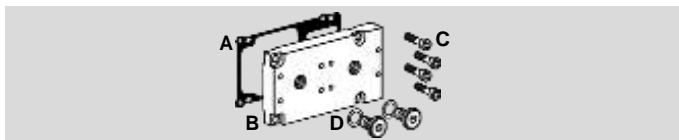

Scope of delivery:

- A 1 x seal,
- B 1 x measuring plate,
- C 4 x M5 set screws,
- D 2 x screw plugs with sealing rings.

7.8 .3 Relief line adapter

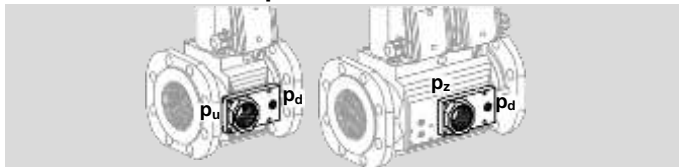

For the connection of a relief line (1½ NPT, Rp 1), with a screw plug or pressure test nipple.

Rp 1, VAS/VCS 6–9, Order No. 74923025,
 1½ NPT, VAS..T/VCS..T 6–9, Order No. 74923024.

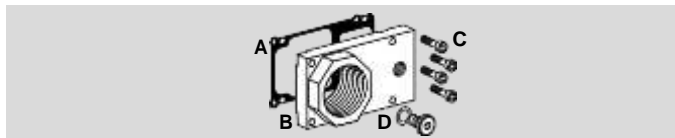

Scope of delivery:

- A 1 x seal,
- B 1 x Z flange,
- C 4 x M5 set screws,
- D 1 x screw plug with sealing ring

7.9 Cable gland with pressure equalization element

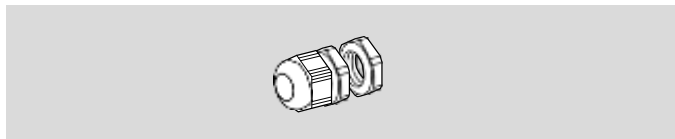

To avoid the formation of condensation, the cable gland with pressure equalization element can be used instead of the standard M20 cable gland. The diaphragm in the gland is designed to ventilate the device, without allowing water to enter.

1 x cable gland, Order No.: 74924686.

7.10 Measuring orifice VMO

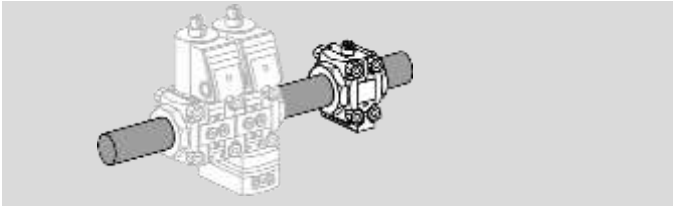

The measuring orifice VMO is designed to reduce the gas and air flow rates and is installed downstream of the valve control. The measuring orifice is available with Rp internal thread (NPT internal thread) or flange to ISO 7005.

Technical Information VMO, see www.docuthek.com.

7.11 Filter module VMF

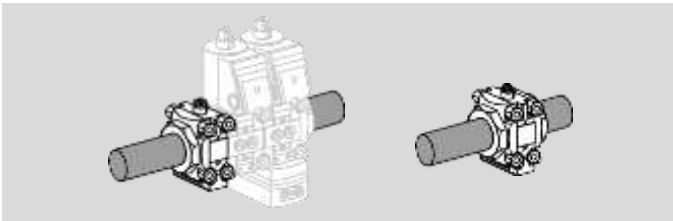

Using the filter module VMF, the gas flow upstream of the gas solenoid valve VAS and the air/gas ratio control is cleaned. The filter module is available with Rp internal thread (NPT internal thread) or flange to ISO 7005 and can also be supplied with fitted pressure switch as an option.

Technical Information VMF, see www.docuthek.com.

7.12 Fine-adjusting valve VMV

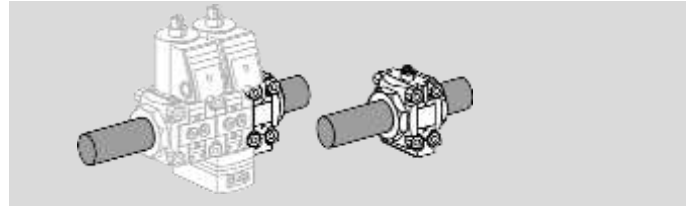

The flow rate is set using the fine-adjusting valve VMV. The fine-adjusting valve is available with Rp internal thread (NPT internal thread) or flange to ISO 7005.

Technical Information VMV, see www.docuthek.com.

7.13 Tightness control TC 1V

TC 1V checks the tightness of two safety valves before or after burner run. For further information, see www.docuthek.com.

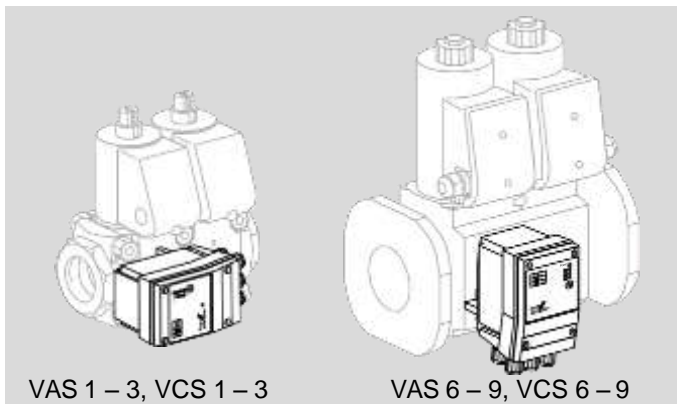

Control voltage = mains voltage

TC 1V05W/W, Order No. 84765541,

TC 1V05Q/Q, Order No. 84765543,

TC 1V05K/K, Order No. 84765545.

Control voltage = 24 V DC

TC 1V05W/K, Order No. 84765542,

TC 1V05Q/K, Order No. 84765544.

7.13.1 Type code

TC	Tightness control
1V	For attachment to valVario
05	p _u max. 500 mbar
W	Mains voltage 230 V AC, 50/60 Hz
Q	Mains voltage 120 V AC, 50/60 Hz
K	Mains voltage 24 V DC
/W	Control voltage: 230 V AC, 50/60 Hz
/Q	Control voltage: 120 V AC, 50/60 Hz
/K	Control voltage: 24 V DC

7.14 Valve connection cable

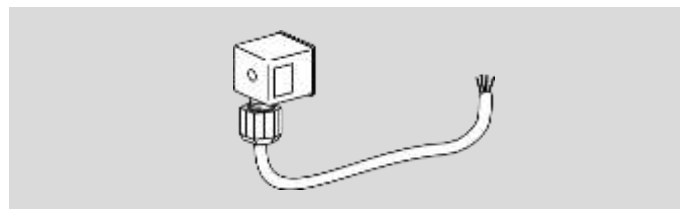

Standard socket, 3 pins + PE, black, 4-core electrical cable, cable length 0.45 m, Order No. 74960689

7.15 Adapter for length compensation

VAS 6–9

For length compensation when replacing VG by VAS 6–9.

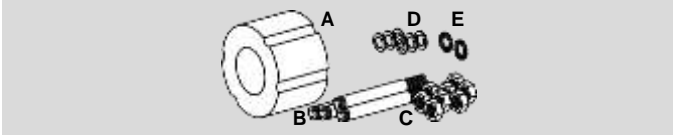

Adapter for length compensation:

VAS 6, Order No. 74923271,

VAS 7, Order No. 74923272,

VAS 8, Order No. 74923273,

VAS 9, Order No. 74923274.

Scope of delivery for VAS/VCS 6:

A 1 x adapter for length compensation,

B 4 x threaded bolts,

C 8 x nuts,

D 6 x washers,

E 2 x serrated lock washers.

Scope of delivery for VAS/VCS 7 to 9:

A 1 x adapter for length compensation,

B 8 x threaded bolts,

C 16 x nuts,

D 14 x washers,

E 2 x serrated lock washers.

8 Technical data

8.1 Ambient conditions

Icing, condensation and dew in and on the unit are not permitted.

Avoid direct sunlight or radiation from red-hot surfaces on the unit. Note the maximum medium and ambient temperatures!

Avoid corrosive influences, e.g. salty ambient air or SO₂.

The unit may only be stored/installed in enclosed rooms/buildings.

The unit is suitable for a maximum installation height of 2000 mAMSL.

Ambient temperature: -20 to +60°C (-4 to +140°F), no condensation permitted.

Long-term use in the upper ambient temperature range accelerates the ageing of the elastomer materials and reduces the service life (please contact manufacturer).

Storage temperature: -20 to +40°C (-4 to +104°F).

Enclosure: IP 65.

This unit is not suitable for cleaning with a high-pressure cleaner and/or cleaning products.

8.2 Mechanical data

Gas types: natural gas, LPG (gaseous), biogas (max. 0.1 %-by-vol. H₂S) or clean air; other types of gas on request. The gas must be clean and dry in all temperature conditions and must not contain condensate.

Medium temperature = ambient temperature.

CE and FM approved, UL listed, max. inlet pressure p_u: 500 mbar (7.25 psig).

FM approved, non operational pressure: 700 mbar (10 psig).
ANSI/CSA approved: 350 mbar (5 psig).

Flow adjustment limits the maximum flow rate to between approx. 20 and 100%.

Adjustment of the start gas rate: 0 to approx. 70%.

Opening times:

VAS../N quick opening: ≤ 1 s;

VAS../L slow opening: up to 10 s.

Closing time:

VAS../N, VAS../L quick closing: < 1 s.

Switching frequency: VAS../N: max. 30 x per minute.

VAS../L: there must be a period of 20 seconds between switching off and on again so that the damping is fully effective.

Safety valve:

Class A, Group 2 pursuant to EN 13611 and EN 161,
Factory Mutual (FM) Research Class: 7400 and 7411,
ANSI Z21.21 and CSA 6.5.

Valve housing: aluminium, valve seal: NBR.

Connection flanges:

Up to size 3: Rp to ISO 7-1, NPT to ANSI/ASME;
size 2 and higher: with PN 16 ISO flange (pursuant to ISO 7005), with ANSI flange pursuant to ANSI 150.

Cable gland: M20 x 1.5.

Electrical connection: cable with max. 2.5 mm² (AWG 12) or plug with socket to EN 175301-803.

Duty cycle: 100%.

Power factor of the solenoid coil: cos φ = 0.9.

8.3 Electrical data for VAS 1–3/VCS 1–3

Mains voltage:

230 V AC, +10/-15%, 50/60 Hz;

200 V AC, +10/-15%, 50/60 Hz;

120 V AC, +10/-15%, 50/60 Hz;

100 V AC, +10/-15%, 50/60 Hz;

24 V DC, ±20%.

Power consumption:

Type	Voltage	Power
VAS 1	24 V DC	25 W
VAS 1	100 V AC	25 W (26 VA)
VAS 1	120 V AC	25 W (26 VA)
VAS 1	200 V AC	25 W (26 VA)
VAS 1	230 V AC	25 W (26 VA)
VAS 2, VAS 3	24 V DC	36 W
VAS 2, VAS 3	100 V AC	36 W (40 VA)
VAS 2, VAS 3	120 V AC	40 W (44 VA)
VAS 2, VAS 3	200 V AC	40 W (44 VA)
VAS 2, VAS 3	230 V AC	40 W (44 VA)
VBY	24 V DC	8 W
VBY	120 V AC	8 W
VBY	230 V AC	9.5 W

Contact rating of proof of closure switch:

Type	Voltage	Current (resistive load)	
		min .	max .
VAS..S,VCS..S	12–250 V AC, 50/60 Hz	100 mA	3 A
VAS..G,VCS..G	12–30 V DC	2 mA	0.1 A

Switching frequency of proof of closure switch: max. 5 x per minute.

Switching current	Switching cycles*	
	cos φ = 1	cos φ = 0.6
0.1	500,000	500,000
0.5	300,000	250,000
1	200,000	100,000
3	100,000	–

* Limited to max. 200,000 cycles for heating systems.

8.4 Electrical data for VAS 6–9/VCS 6–9

Mains voltage for VAS 6–8/VCS 6–8:

120 V AC, +10/-15%, 50/60 Hz,

230 V AC, +10/-15%, 50/60 Hz,

24 V DC, ±20%.

Mains voltage for VAS 9/VCS 9:

120–230 V AC, +10/-15%, 50/60 Hz.

Switching frequency: max. 1 x per minute.

Max. temperature of solenoid coil:

+20°C (+68°F) above ambient temperature.

Current consumption at 20°C (68°F):

Pick-up current: 1.8 A,

holding current: 0.3 A.

Power consumption:

Type	Voltage	Power
VAS 6	24 V DC	70 W
VAS 6	120 V AC	63 W
VAS 6	230 V AC	63 W
VAS 7	24 V DC	75 W
VAS 7	120 V AC	90 W
VAS 7	230 V AC	83 W
VAS 8	24 V DC	99 W
VAS 8	120 V AC	117 W
VAS 8	230 V AC	113 W
VAS 9	24 V DC	-
VAS 9	120 V AC	200 (15*) W
VAS 9	230 V AC	200 (15*) W
VCS 6	24 V DC	140 W
VCS 6	120 V AC	126 W
VCS 6	230 V AC	126 W
VCS 7	24 V DC	150 W
VCS 7	120 V AC	180 W
VCS 7	230 V AC	166 W
VCS 8	24 V DC	198 W
VCS 8	120 V AC	234 W
VCS 8	230 V AC	226 W
VCS 9	24 V DC	-
VCS 9	120 V AC	400 (30*) W
VCS 9	230 V AC	400 (30*) W

* After opening.

Contact rating of proof of closure switch:

Type	Voltage	Current (resistive load)	
		min .	max .
VAS..S, VCS..S	12–250 V AC, 50/60 Hz	100 mA	3 A
VAS..G, VCS..G	12–30 V DC	2 mA	0.1 A

Switching frequency of proof of closure switch: max. 5 x per minute.

Switching current	Switching cycles*	
	cos ϕ = 1	cos ϕ = 0.6
0.1	500,000	500,000
0.5	300,000	250,000
1	200,000	100,000
3	100,000	-

* Limited to max. 200,000 cycles for heating systems.

9 Dimensions

9.1 VAS 1-3 with Rp internal thread [mm]

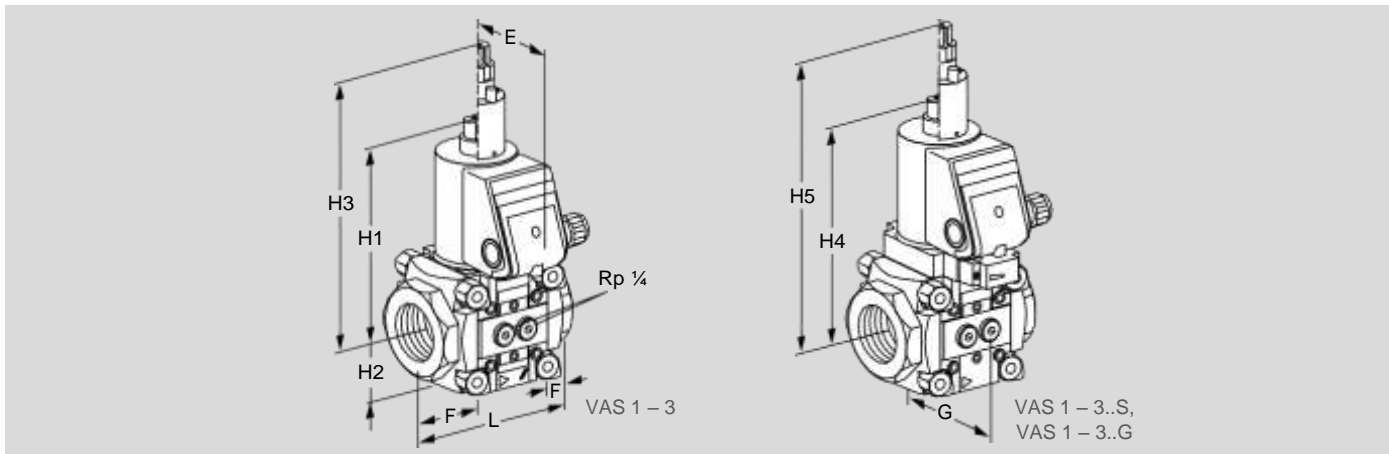

Type	Connection		Dimensions [mm]									Weight [kg]
	Rp	DN	L	E	F	G	H1	H2	H3	H4	H5	
VAS 110	3/8	10	75	75	15	67.3	143	32	208	161	226	1.4
VAS 115	1/2	15	75	75	15	67.3	143	32	208	161	226	1.4
VAS 120	3/4	20	91	75	23	67.3	143	32	208	161	226	1.5
VAS 125	1	25	91	75	23	67.3	143	32	208	161	226	1.4
VAS 225	1	25	127	85	29	98.2	170	47	235	191	256	3.8
VAS 232	1 1/4	32	127	85	29	98.2	170	47	235	191	256	3.8
VAS 240	1 1/2	40	127	85	29	98.2	170	47	235	191	256	3.8
VAS 250	2	50	127	85	29	98.2	170	47	235	191	256	3.6
VAS 340	1 1/2	40	155	85	36	113.3	180	59	245	201	266	5.2
VAS 350	2	50	155	85	36	113.3	180	59	245	201	266	5.0
VAS 365	2 1/2	65	155	85	36	113.3	180	59	245	201	266	4.8

9.2 VAS 2-9 with ISO flange [mm]

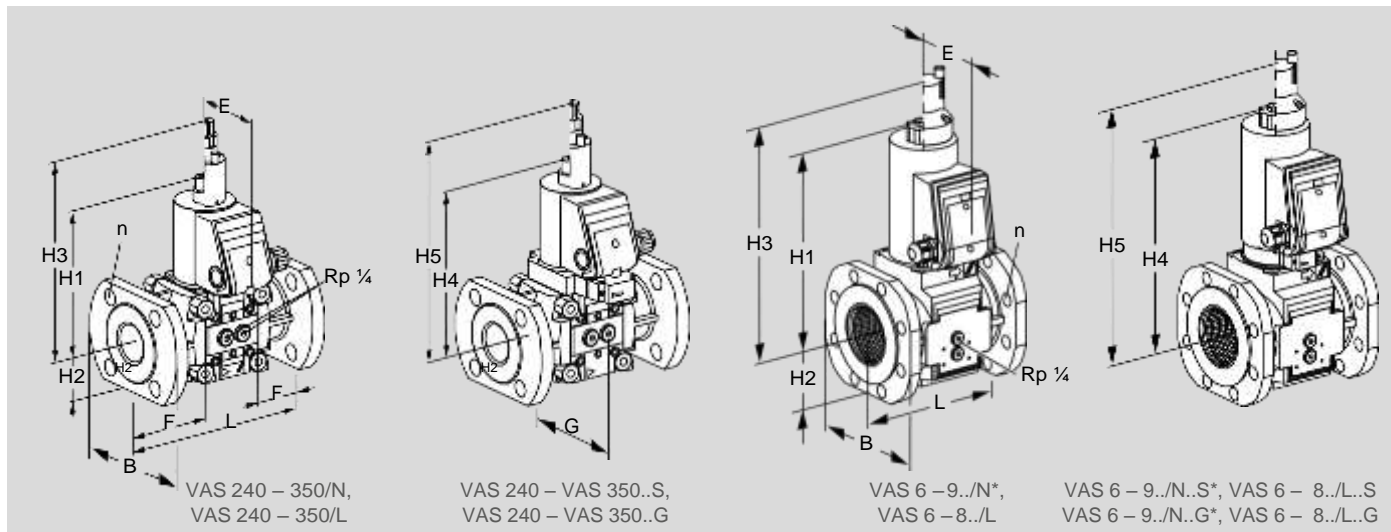

Type	Conne- ction DN	Dimensions [mm]										n	Weight [kg]
		L	E	F	G	B	H1	H2	H3	H4	H5		
VAS 240	40	200	85	66	98.2	150	175	56	240	196	258	4	5
VAS 350	50	230	85	74	113.3	165	180	65	245	200	265	4	6.5
VAS 665	65	190	106	–	–	175	285	77	340	310	365	4	11
VAS 780	80	203	106	–	–	190	295	88	350	320	380	8	12
VAS 8100	100	229	120	–	–	210	350	103	405	380	430	8	23
VAS 9125*	125	254	120	–	–	240	365	114	–	395	–	8	27

* VAS 9 only available without damping unit

9.3 VCS 1–3 with Rp internal thread [mm]

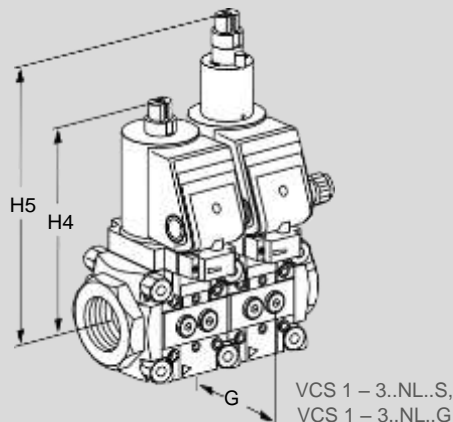
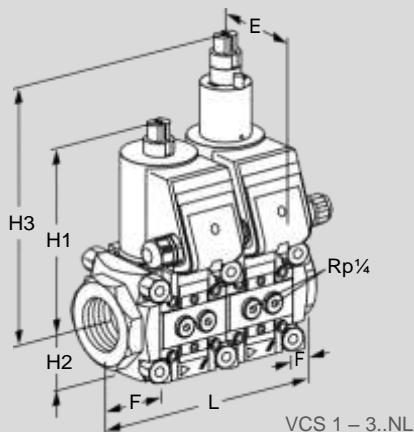

Type	Connection		Dimensions [mm]									Weight [kg]
	Rp	DN	L	E	F	G	H1	H2	H3	H4	H5	
VCS 110	3/8	10	120	75	15	67.3	143	32	208	161	226	2.6
VCS 115	1/2	15	120	75	15	67.3	143	32	208	161	226	2.6
VCS 120	3/4	20	136	75	23	67.3	143	32	208	161	226	2.7
VCS 125	1	25	136	75	23	67.3	143	32	208	161	226	2.5
VCS 225	1	25	196	85	29	98.2	170	47	235	191	256	6.8
VCS 232	1 1/4	32	196	85	29	98.2	170	47	235	191	256	6.9
VCS 240	1 1/2	40	196	85	29	98.2	170	47	235	191	256	6.8
VCS 250	2	50	196	85	29	98.2	170	47	235	191	256	6.6
VCS 340	1 1/2	40	238	85	36	113.3	180	59	245	201	266	8.8
VCS 350	2	50	238	85	36	113.3	180	59	245	201	266	8.6
VCS 365	2 1/2	65	238	85	36	113.3	180	59	245	201	266	8.5

9.4 VCS 2–9 with ISO flange [mm]

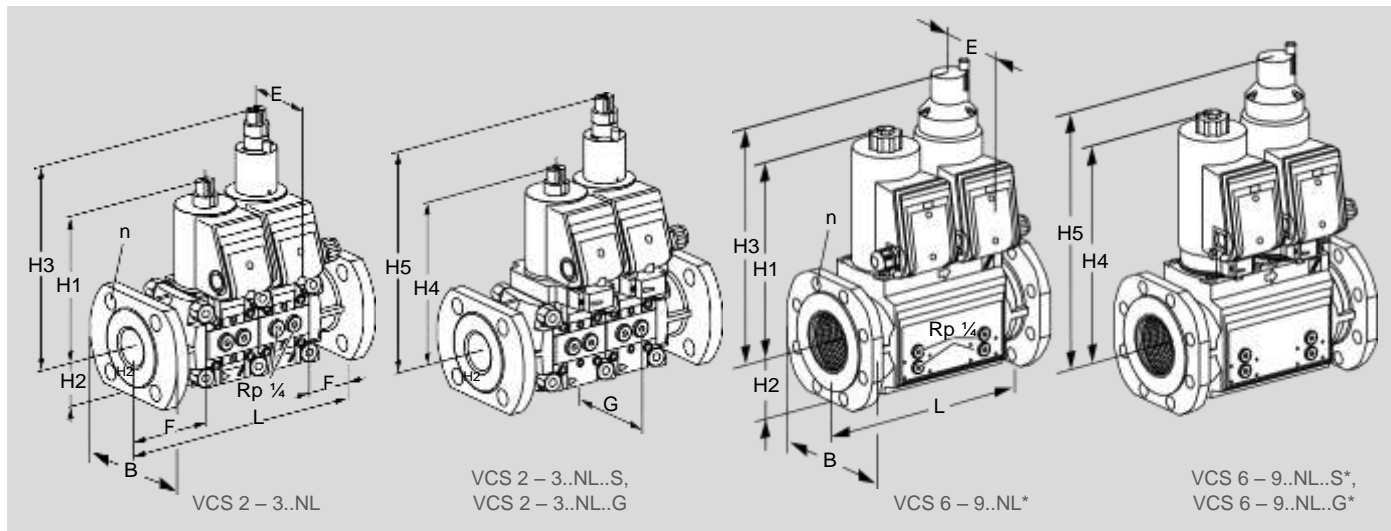

Type	Conne- ction		Dimensions [mm]									n	Weight [kg]
	DN	L	E	F	G	B	H1	H2	H3	H4	H5		
VCS 240	40	270	85	66	98.2	150	175	56	240	196	258	4	8.3
VCS 350	50	314	85	74	113.3	165	180	65	245	200	265	4	10.8
VCS 665	65	295	106	–	–	175	285	77	340	310	365	4	18
VCS 780	80	310	106	–	–	190	295	88	350	320	380	8	21
VCS 8100	100	350	120	–	–	210	350	103	405	380	430	8	40
VCS 9125*	125	400	120	–	–	240	365	114	–	395	–	8	45

* VCS 9 only available without damping unit

9.5 VAS 1-3 . .T with NPT internal thread [inch]

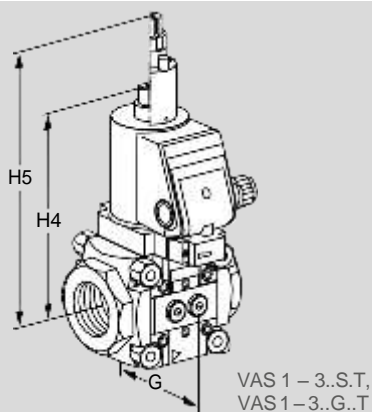
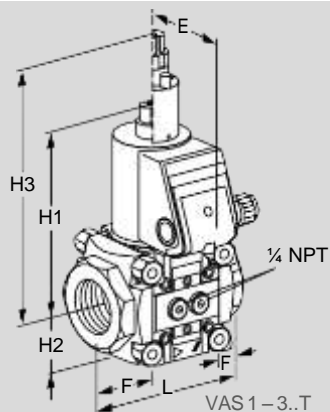

Type	Connection		Dimensions [inch]									Weight [lbs]
	NPT	DN	L	E	F	G	H1	H2	H3	H4	H5	
VAS 110	3/8	10	2.95	2.95	0.59	2.65	5.63	1.26	8.19	6.34	8.9	3.08
VAS 115	1/2	15	2.95	2.95	0.59	2.65	5.63	1.26	8.19	6.34	8.9	3.08
VAS 120	3/4	20	3.58	2.95	0.91	2.65	5.63	1.26	8.19	6.34	8.9	3.30
VAS 125	1	25	3.58	2.95	0.91	2.65	5.63	1.26	8.19	6.34	8.9	3.08
VAS 225	1	25	5.00	3.32	1.14	3.87	6.69	1.85	9.25	7.52	10.1	8.36
VAS 232	1 1/4	32	5.00	3.32	1.14	3.87	6.69	1.85	9.25	7.52	10.1	8.36
VAS 240	1 1/2	40	5.00	3.32	1.14	3.87	6.69	1.85	9.25	7.52	10.1	8.36
VAS 250	2	50	5.00	3.32	1.14	3.87	6.69	1.85	9.25	7.52	10.1	7.92
VAS 340	1 1/2	40	6.10	3.32	1.42	4.46	7.09	2.3	9.65	7.91	10.5	11.40
VAS 350	2	50	6.10	3.32	1.42	4.46	7.09	2.3	9.65	7.91	10.5	11.00
VAS 365	2 1/2	65	6.10	3.32	1.42	4.46	7.09	2.3	9.65	7.91	10.5	10.56

9.6 VAS 6–9 . .T with ANSI flange [inch]

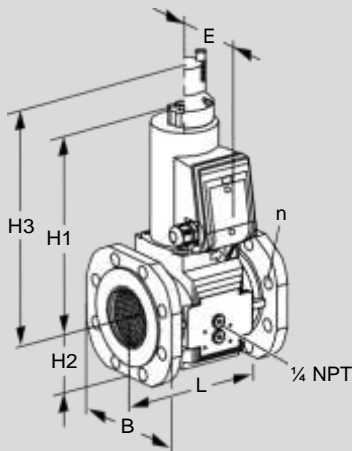

VAS 6 – 9..T../N*

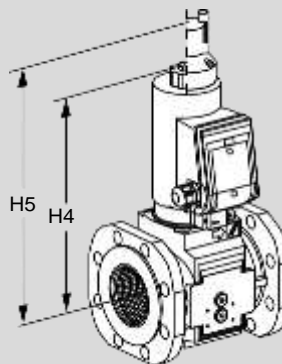

VAS 6 – 8..T../L

Type	Connection	Dimensions [inch]								n	Weight [lbs]
		DN	L	E	B	H1	H2	H3	H4		
VAS 665	65	7.48	4.17	6.89	11.2	3.03	13.4	12.2	14.4	4	24.25
VAS 780	80	7.99	4.17	7.48	11.6	3.46	13.8	12.6	15.0	4	26.45
VAS 8100	100	9	4.72	8.27	13.8	4.06	15.9	15.0	16.9	8	50.71
VAS 9125*	125	10	4.72	9.45	14.4	4.49	–	15.6	–	8	59.52

* VAS 9 only available without damping unit

9.7 VCS 1-3 . . T with NPT internal thread [inch]

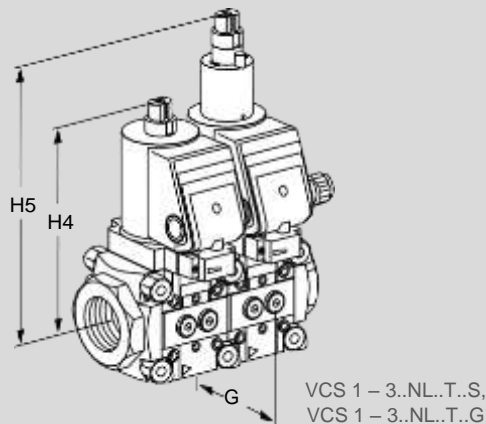
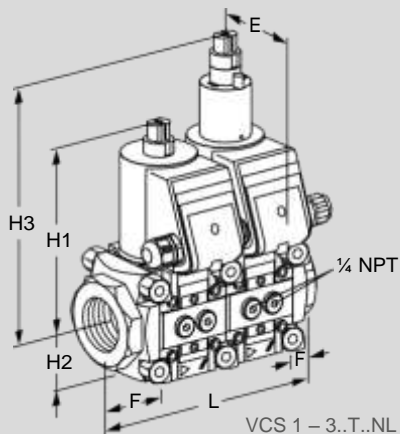

Type	Connection		Dimensions [inch]									Weight [lbs]
	NPT	DN	L	E	F	G	H1	H2	H3	H4	H5	
VCS 110	3/8	10	4.72	2.95	0.59	2.65	5.63	1.26	8.19	6.34	8.9	5.72
VCS 115	1/2	15	4.72	2.95	0.59	2.65	5.63	1.26	8.19	6.34	8.9	5.72
VCS 120	3/4	20	5.35	2.95	0.91	2.65	5.63	1.26	8.19	6.34	8.9	5.94
VCS 125	1	25	5.35	2.95	0.91	2.65	5.63	1.26	8.19	6.34	8.9	5.72
VCS 225	1	25	7.72	3.32	1.14	3.87	6.69	1.85	9.25	7.52	10.1	14.96
VCS 232	1 1/4	32	7.72	3.32	1.14	3.87	6.69	1.85	9.25	7.52	10.1	15.18
VCS 240	1 1/2	40	7.72	3.32	1.14	3.87	6.69	1.85	9.25	7.52	10.1	14.96
VCS 250	2	50	7.72	3.32	1.14	3.87	6.69	1.85	9.25	7.52	10.1	14.52
VCS 340	1 1/2	40	9.37	3.32	1.42	4.46	7.09	2.3	9.65	7.91	10.5	19.36
VCS 350	2	50	9.37	3.32	1.42	4.46	7.09	2.3	9.65	7.91	10.5	18.92
VCS 365	2 1/2	65	9.37	3.32	1.42	4.46	7.09	2.3	9.65	7.91	10.5	18.70

9.8 VCS 6–9 . .T with ANSI flange [inch]

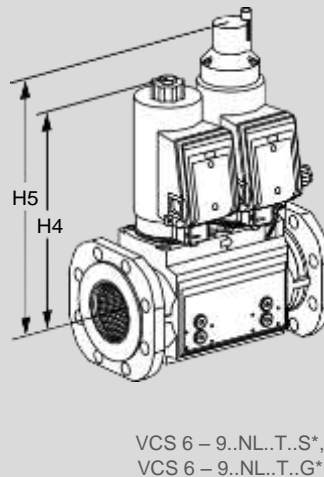
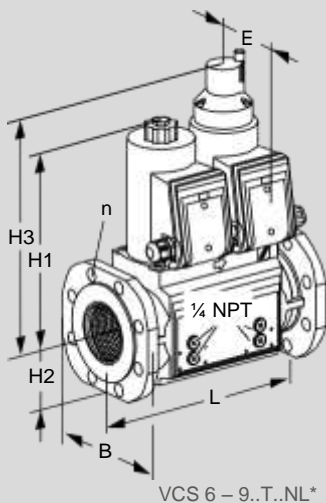

Type	Conne- tion DN	Dimensions [inch]								n	Weight [lbs]
		L	E	B	H1	H2	H3	H4	H5		
VCS 665	65	11.41	4.17	6.89	11.2	3.03	13.4	12.2	14.4	4	39.68
VCS 780	80	12.20	4.17	7.48	11.6	3.46	13.8	12.6	15.0	4	46.30
VCS 8100	100	13.78	4.72	8.27	13.8	4.06	15.9	15.0	16.9	8	88.18
VCS 9125*	125	15.75	4.72	9.45	14.4	4.49	–	15.6	–	8	99.21

* VCS 9 only available without damping unit

10 Converting units

See www.adlatus.org

11 Safety-specific characteristic values for SIL and PL

Certificates – see www.docuthek.com.

For a glossary of terms, see page 67 (Glossary).

For SIL	
Suitable for Safety Integrity Level	SIL 1, 2, 3
Diagnostic coverage DC	0
Type of subsystem	Type A to EN 61508-2, 7.4.4.1.3
Mode of operation	High demand mode pursuant to EN 61508-4, 03/05/2016
For PL	
Suitable for Performance Level	PL a, b, c, d, e
Category	B, 1, 2, 3, 4
Common cause failure CCF	> 65
Application of essential safety requirements	Satisfied
Application of tried-and-tested safety requirements	Satisfied
For SIL and PL	
B _{10d} value of VAS 1	15,845,898 operating cycles
B _{10d} value of VAS 2–3	15,766,605 operating cycles
B _{10d} value of VAS 6–9	6,700,000 operating cycles
Hardware fault tolerance (1 component/switch) HFT	0
Hardware fault tolerance (2 components/switches, redundant operation) HFT	1
Safe failure fraction SFF	> 90%
Fraction of undetected common cause failures β	≥ 2%

Relationship between the Performance Level (PL) and the Safety Integrity Level (SIL)

PL	SIL
a	–
b	1
c	1
d	2
e	3

11.1 Determining the PFH_D value, λ_D value and MTTF_d value

$$PFH_D = \lambda_D = \frac{1}{MTTF_d} = \frac{0,1}{B_{10d}} \times n_{op}$$

PFH_D = Probability of dangerous failure (HDM = high demand mode) [1/hour]

PFD_{avg} = Average probability of a dangerous failure of the safety function on demand (LDM = low demand mode)

λ_D = Mean dangerous failure rate [1/hour]

MTTF_d = Mean time to dangerous failure [hours]

n_{op} = Demand rate (mean number of annual operations) [1/hour]

11 .2 Designed lifetime

Max. service life under operating conditions in accordance with EN 13611, EN 161 for VAS, VCS:
 designed lifetime after date of production, plus max. ½ year in storage prior to first use, or once the given number of operating cycles has been reached, depending on which is achieved first:

Type	Designed lifetime	
	Switching cycles	Time (years)
VAS 110 to 225	500,000	10
VAS 232 to 365	200,000	10
VAS/VCS 665 to 780	100,000	10
VAS/VCS 8100 to 9125	50,000	10

11 .3 Use in safety-related systems

For systems up to SIL 3 pursuant to EN 61508 and PL e pursuant to ISO 13849.

The devices are suitable for single-channel systems (HFT = 0) up to SIL 2/PL d, and up to SIL 3/PL e when two redundant devices are installed in a double-channel architecture (HFT = 1), provided that the complete system complies with the requirements of EN 61508/ISO 13849.

and external tightness.

12 Safety information in accordance with EN 61508-2

12.1 Scope of application

The gas solenoid valves are designed for shutting off the gas supply to gas burners and gas appliances.

For further information, see page 11 (Certification) and page 4 (Application).

12.2 Product description

See page 12 (Function) and page 4 (Application). for information about the product description and the device functions.

12.3 Reference documents

Operating instructions, see www.docuthek.com.

Certificate, see www.docuthek.com.

A web app for spare parts is available at www.adlatus.org.

A web app selecting the correct product is available at www.adlatus.org.

12.4 Applicable standards

Standards used for certification, see www.docuthek.com.

12.5 Safety function

The safety function involves interrupting a gas flow by adopting the safety position using the internal energy accumulator within the closing time and guaranteeing internal

12.6 Safety instructions concerning operating limits

The function is only guaranteed when used within the specified limits – see page 50 (Technical data) or operating instructions at www.docuthek.com.

12.7 Installation and commissioning

Installation and commissioning procedures are described in the operating instructions.

12.8 Maintenance/Checks

Internal and external tightness and the function once per annum, twice per annum for biogas.
Further information can be found in the operating instructions.

12.9 Troubleshooting

In the event of faults after maintenance work or function checks: remove the unit and return it to the manufacturer for inspection.

12.10 Safety instructions concerning design verification

A Failure Mode and Effects Analysis has been carried out to assess possible design-related failures and to classify these into safe and dangerous failures.

12.11 Characteristic safety data/SIL capability

See page 62 (Safety-specific characteristic values for SIL and PL) and page 50 (Technical data).

12.12 Mode of operation

The gas solenoid valves are suitable for a 100% duty cycle.

13 Maintenance cycles

At least once a year, at least twice a year in the case of biogas.

If the flow rate drops, clean the strainer.

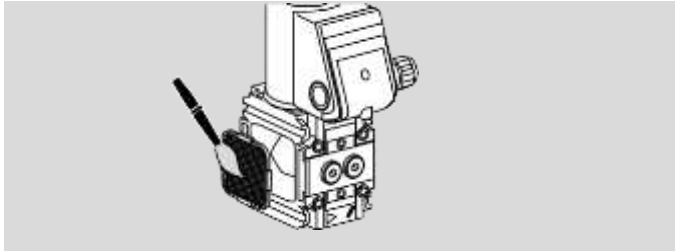

VAS

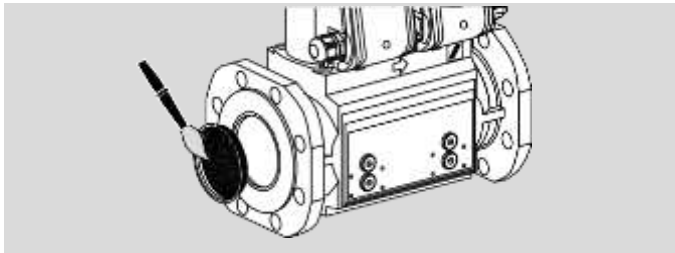

VCS

14 Glossary

14 .1 Diagnostic coverage DC

Measure of the effectiveness of diagnostics, which may be determined as the ratio between the failure rate of detected dangerous failures and the failure rate of total dangerous failures

NOTE: Diagnostic coverage can exist for the whole or parts of a safety-related system. For example, diagnostic coverage could exist for sensors and/or logic system and/or final elements. Unit: %

see EN ISO 13849-1

14 .2 Mode of operation

High demand mode or continuous mode

Operating mode, where the frequency of demands for operation made on a safety-related system is greater than one per year or greater than twice the proof-test frequency

see EN 61508-4

14 .3 Category

Classification of the safety-related parts of a control system in respect of their resistance to faults and their subsequent behaviour in the fault condition, and which is achieved by the structural arrangement of the parts, fault detection and/or by their reliability

see EN ISO 13849-1

14 .4 Common cause failure CCF

Failures of different items, resulting from a single event, where these failures are not consequences of each other

see EN ISO 13849-1

14 .5 Fraction of undetected common cause failures β

Fraction of undetected failures of redundant components due to a single event, whereby these failures are not based on mutual causes

NOTE: β is expressed as a fraction in the equations and as a percentage elsewhere.

see EN 61508-6

14 .6 B_{10d} value

Mean number of cycles until 10% of the components fail dangerously

see EN ISO 13849-1

14 .7 T_{10d} value

Mean time until 10% of the components fail dangerously

see EN ISO 13849-1

14 .8 Hardware fault tolerance HFT

A hardware fault tolerance of N means that N + 1 is the minimum number of faults that could cause a loss of the safety function

see IEC 61508-2

14 .9 Mean dangerous failure rate λ_D

Mean rate of dangerous failures during operation time (T_{10d}).

Unit: 1/h

see EN ISO 13849-1

14 .10 Safe failure fraction SFF

Fraction of safe failures related to all failures, which are assumed to appear

see EN 13611/A2

14 .11 Probability of dangerous failure PFH_D

Value describing the likelihood of dangerous failure per hour of a component for high demand mode or continuous mode. Unit: 1/h

1/h

see EN 13611/A2

14 .12 Mean time to dangerous failure $MTTF_d$

Expectation of the mean time to dangerous failure

see EN ISO 13849-1:20

14 .13 Demand rate n_{op}

Mean number of annual operations

see EN ISO 13849-1

14 .14 Average probability of dangerous failure on demand PFD_{avg}

(LDM = 1 – 10 switching cycles/year)

Average probability of a dangerous failure of the safety function on demand (LDM = low demand mode)

see EN 61508-

© 2019 Elster GmbH

We reserve the right to make technical modifications in the interests of progress.